

Pz.Kpfw.IV Ausf.F2 & G

ドイツ IV号戦車F2&G型

2 IN 1

Border

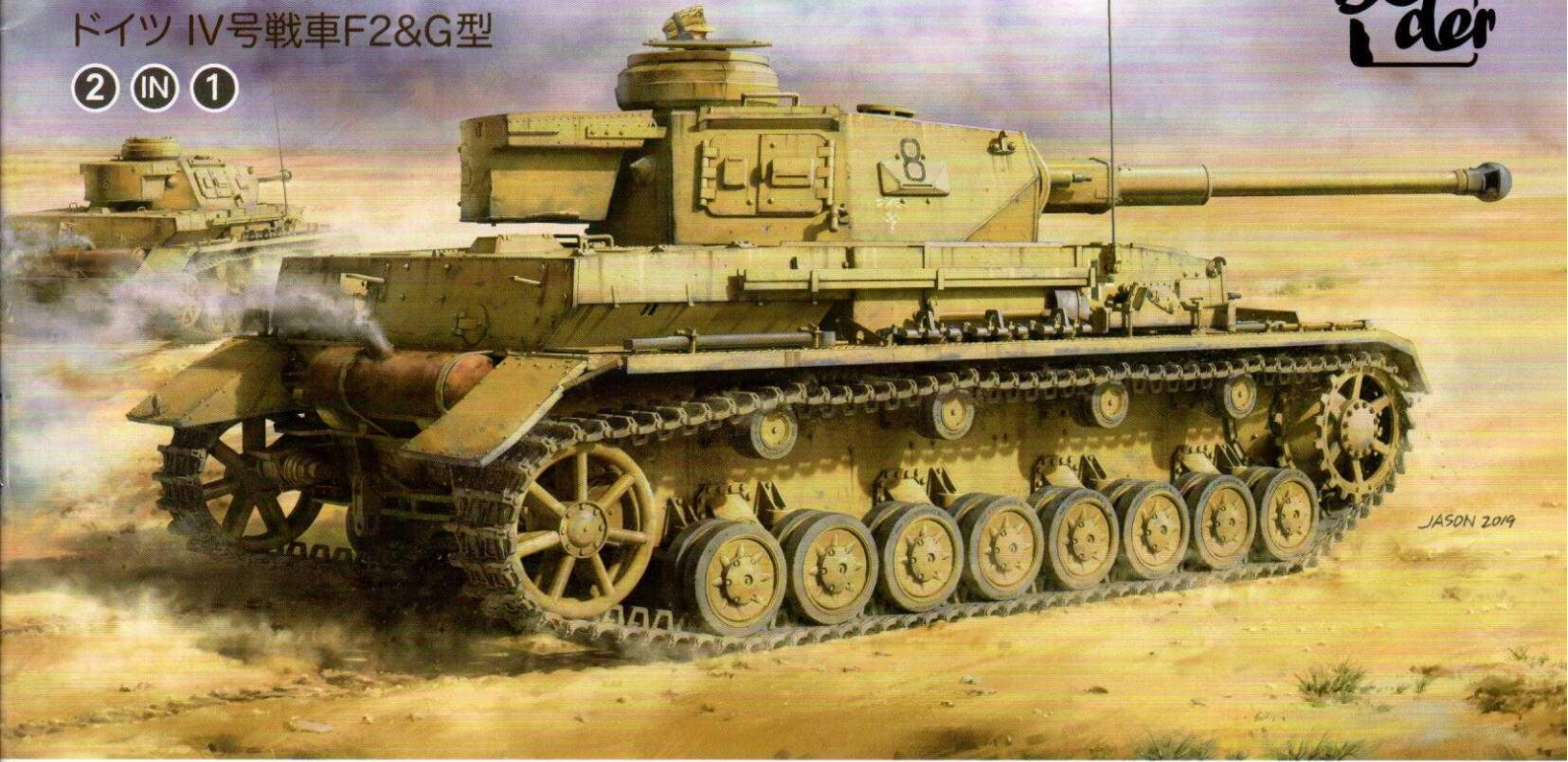

JASON 2019

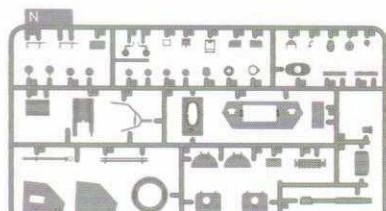
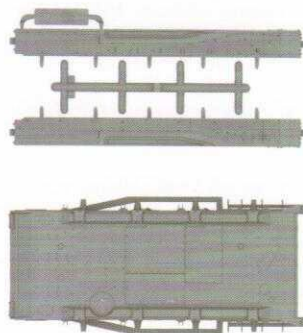
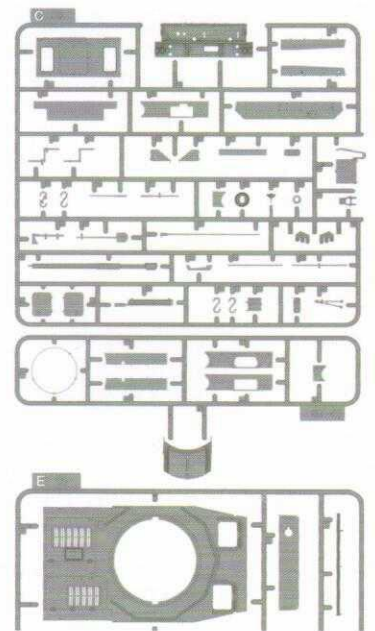
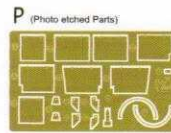
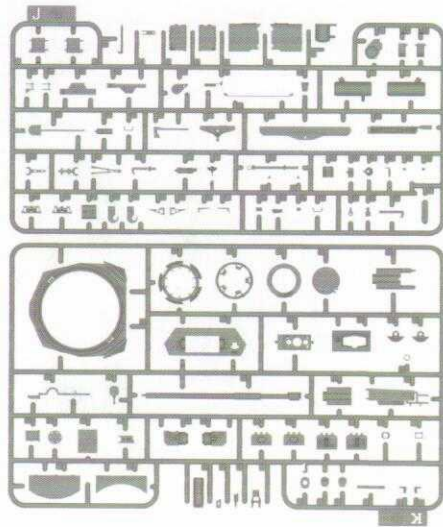
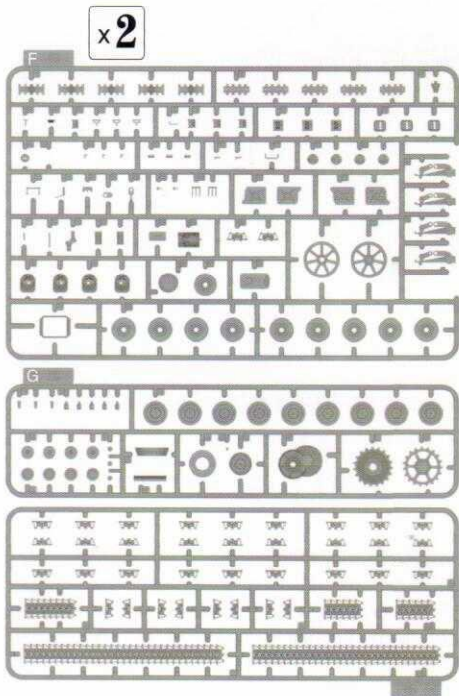

+ 422	+ 4	8	↑ ↑ ↑
+ 422	+ 4	8	+++
+ 422	+ 4	8	∞
+ 311	9	4	242 +
+ 311	9	+	242 +
+ 311	+	+	++
205	205	205	215 215
205	205	205	215 215

LATE DIVISION HATCHKOV '845 BT001 2019 PANZER IV F2&G

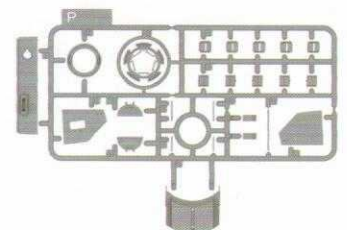

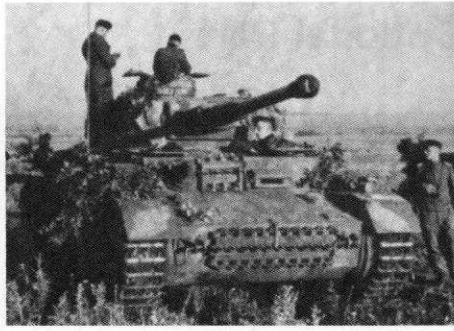

History | 历史介绍

Panzer IV F2 & G

A month after the Operation Barbarossa began, the Germans met the Soviet T-34 medium tank and KV heavy tank. The Panzer IV's short-barrel, low-speed gun could not penetrate their armor. This increased the German demand for a more powerful tank gun. In November 1941, the 50 mm gun that had been decided upon was abandoned in favor of a 75 mm anti-tank gun made of Rheinmetall GmbH, later known as the 75 mm Pak 40 L/46. The gun cannot be put into the turret because of its long recoil. So the military modified it to 75 mm KwK 40 L/43. The Panzer IV type F with the long barrel was called F2, while with the short barrel was called F1. When fired armor-piercing shell, the projectile's muzzle velocity is increased from the previous 430 m/s to 790 m/s, and it can penetrate 77 mm steel plates at a distance of 1,830 m. The original Panzer IV was equipped with a single-chamber ball-shaped muzzle brake on the barrel, but it provided less than half the recoil required. The weight of the tank now increased to 23.6 tons. In addition to the initial production of long barrel, 25 units type F1 were returned to the factory for refit and upgrading of artillery. Three months later, the type F2 was renamed type G, and the early G was not much different from the F2. The F2, partly equipped with a ball-shaped muzzle brake, dazzled in the north African battle of Tunisia, defeated American armored forces several times larger than their own. After that, some appearance modifications were made to the ex-factory F2, which was replaced with the fin square muzzle brake, and the small observation window on the side of the turret was also cancelled. This batch of long barrel Panzer IV was gradually classified into the type G, but there were significant differences from the late type G, including the L48 gun, the 30mm additional armor, and the thickened commander's cupola. So the type G at this stage can be called the early type G.

巴巴罗萨计划开始一个月后，德国人遇见了苏联的T-34中型坦克和KV重型坦克。德军的Panzer IV的短管低速火炮根本无法击穿它们的装甲。这使德军更加需求一门更强的坦克炮。1941年11月，曾经决定使用的50毫米炮又被放弃，改用莱茵金属制的75毫米反坦克炮，该炮后来称为75毫米Pak 40 L/46。由于该炮的后坐力的行程很长，IV号坦克的炮塔根本放不下。因此军方对其进行改良，成为75毫米KwK 40 L/43。这种装备长炮管的IV号坦克F型名为IV号坦克F2型，同时装备短炮管的就改名为F1型。当发射穿甲弹时，炮弹的初速从以前的430米/秒提高到790米/秒，能在1830米外穿透77毫米的钢制装甲板。最初IV号坦克的炮管安装了单腔球形炮口制退器，但它提供的制退能力甚至不到反后座系统需求的一半。坦克的重量此时增加到23.6吨。除了生产时装上长炮管外，有25辆F1型回厂改装并升级火炮。三个月后，IV号坦克F2型重新命名为G型，早期的G型与F2型没有太大分别。F2型有一部分装有球形的炮口制退器，他们在北非战场的突尼斯战役大放光彩，击败了数倍于己的美军装甲部队。之后出厂的F2型又进行了一些外观的修改，换成了后期通用的方形制退器，同样也取消了炮塔侧面的小观测窗。这一批次的长炮管PANZER IV被逐渐归类到G型，但是与中后期的G型又有很大的差别，包括装备的L48火炮，增加的30MM附加装甲，以及加厚型指挥塔。所以这一阶段的G型可以称作G早期型。

1 Assembly of Special Optional Parts 特殊的搭载物品组装

? Optional Parts:
Additional Track from T34 Tank
可选择搭载物:
来自T34坦克的备用履带

(A) x2

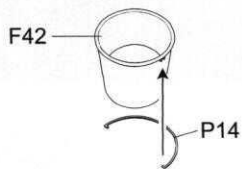

(B) x2

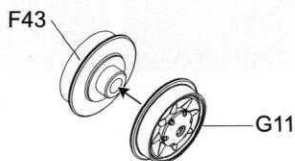

(C) x2

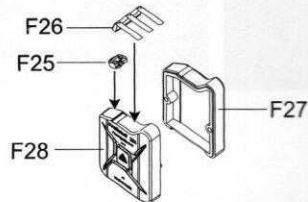

(D) x10

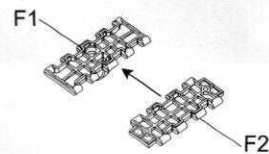

2

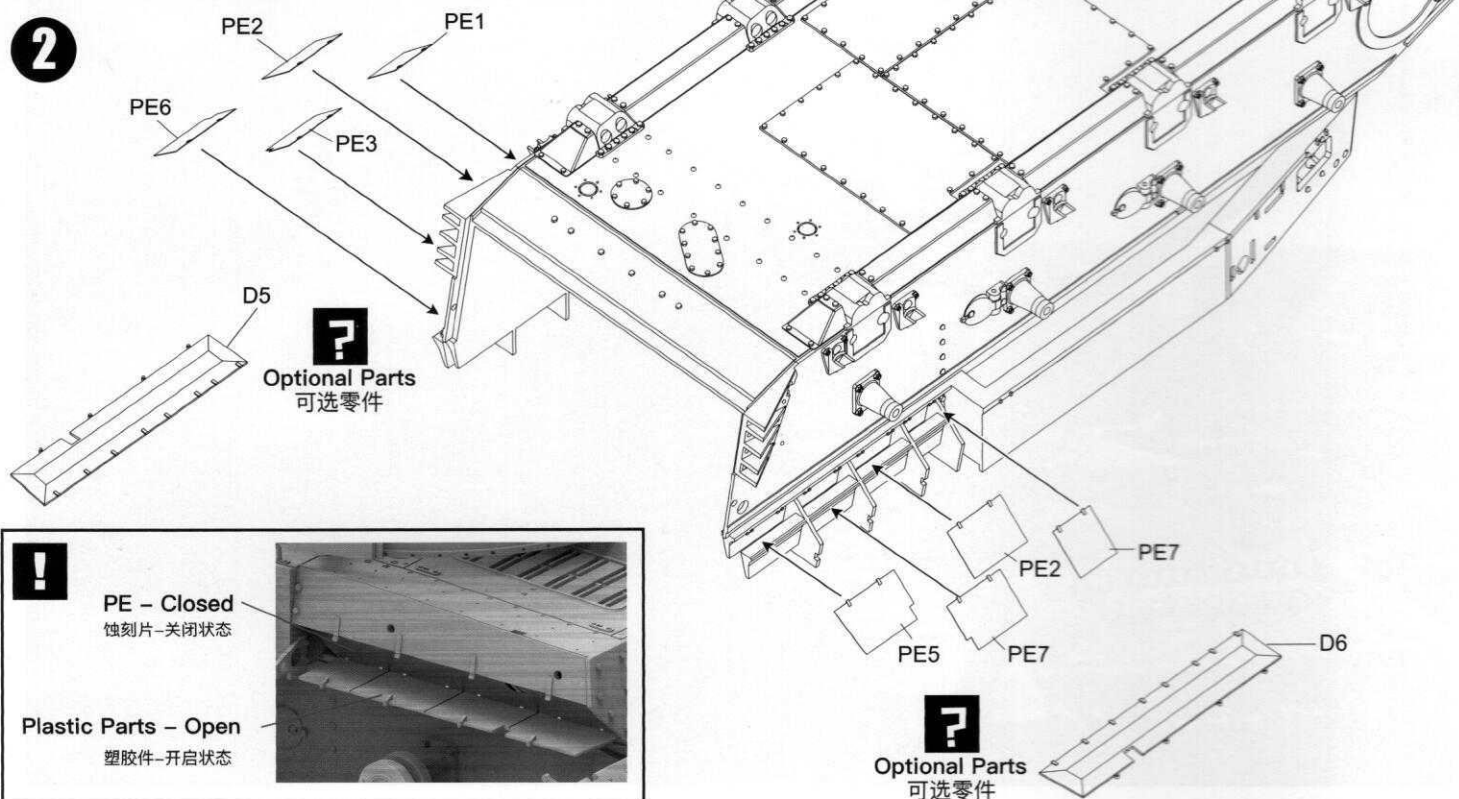

3

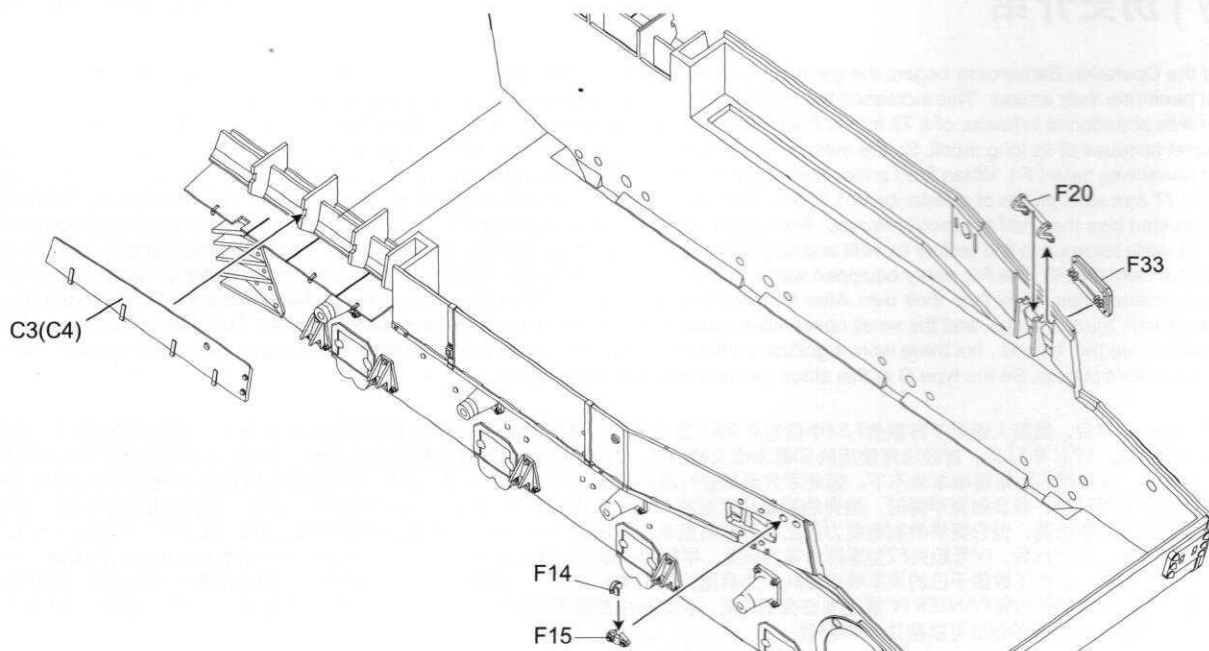

4

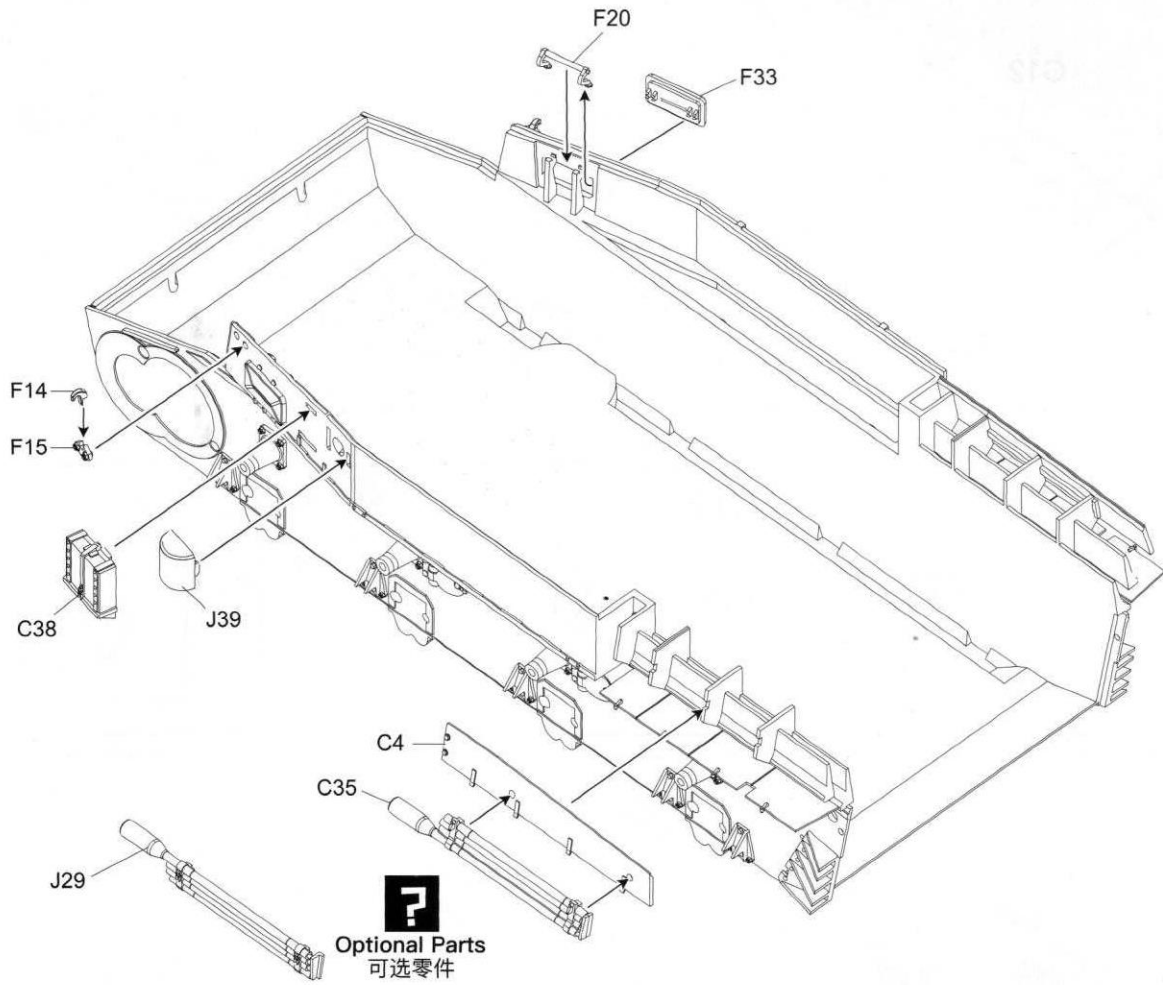

5

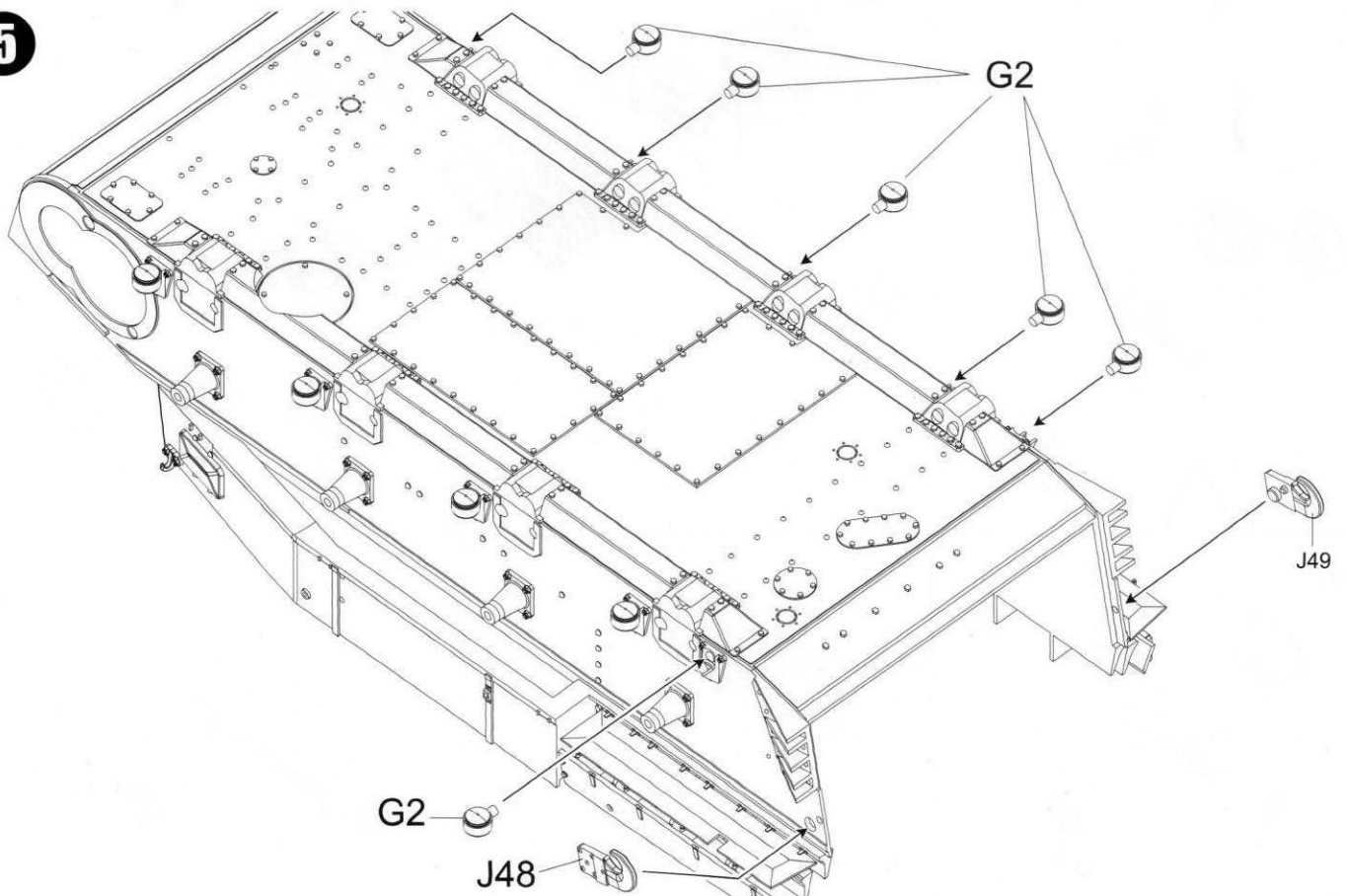

6

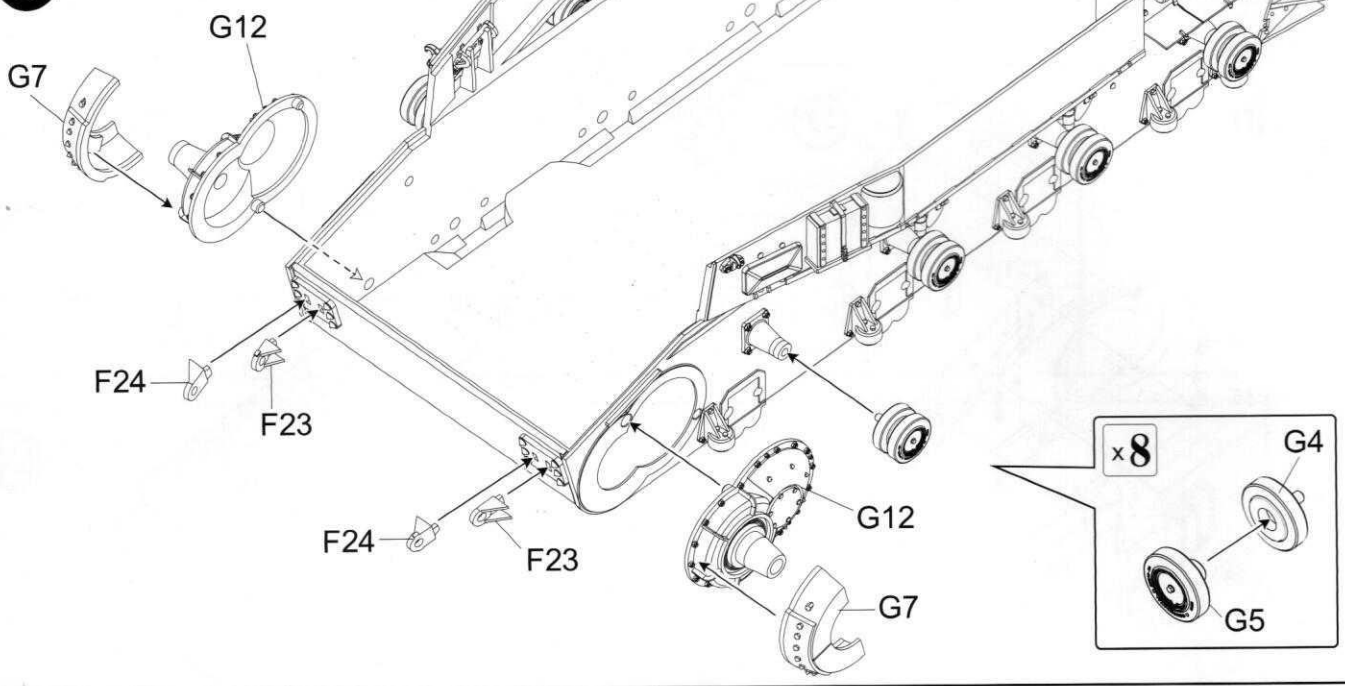

7

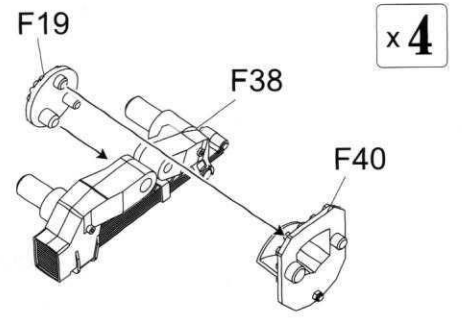
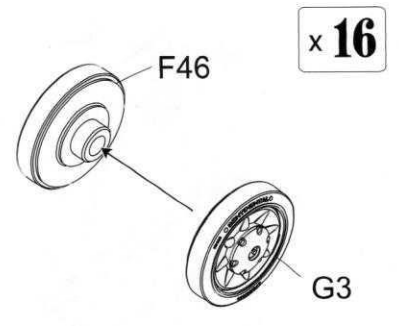
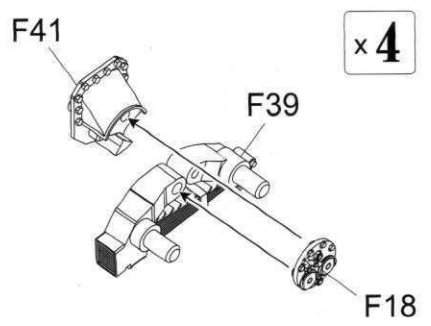
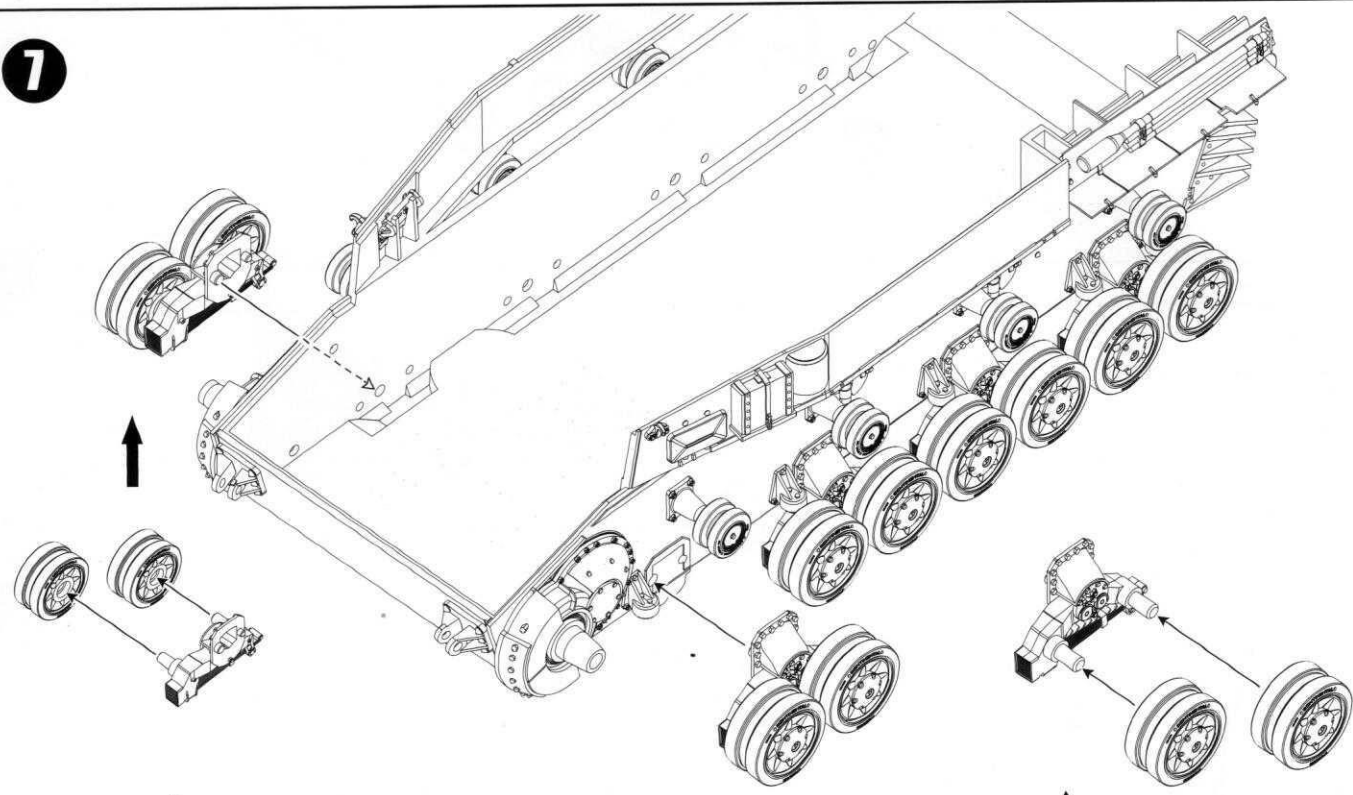

8

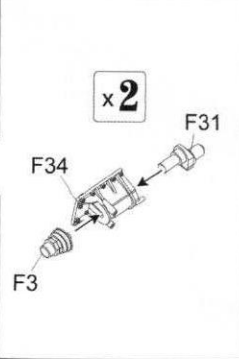
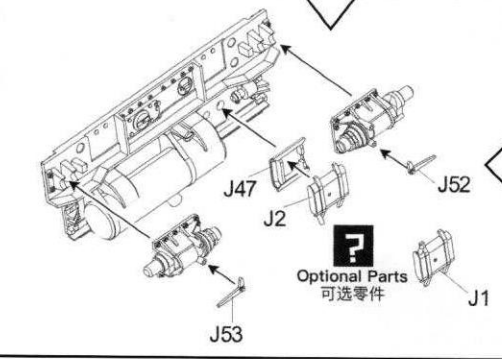
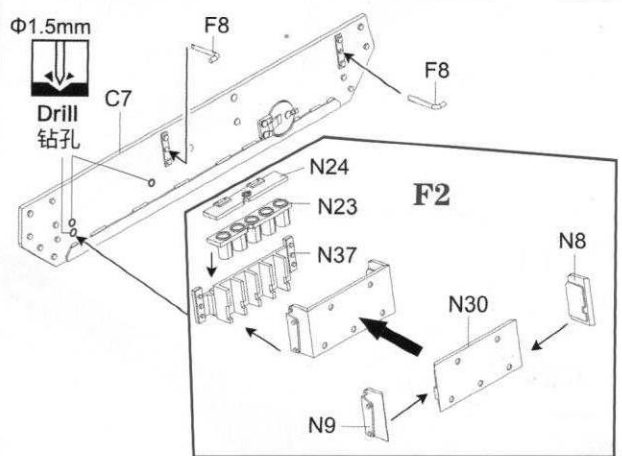
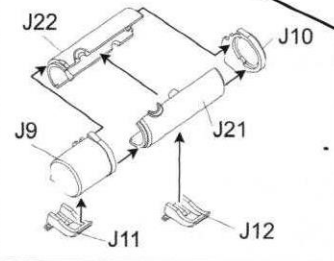
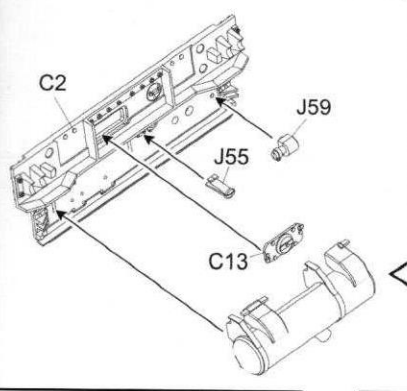
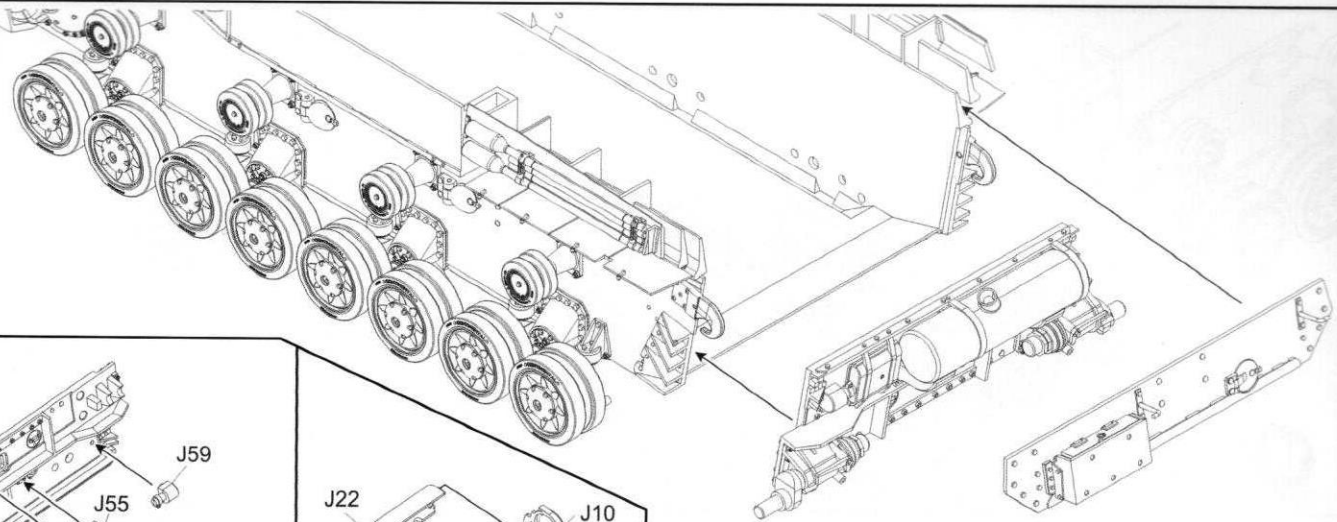

9

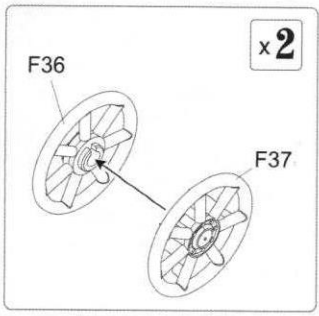
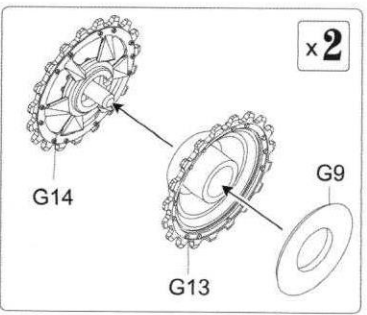
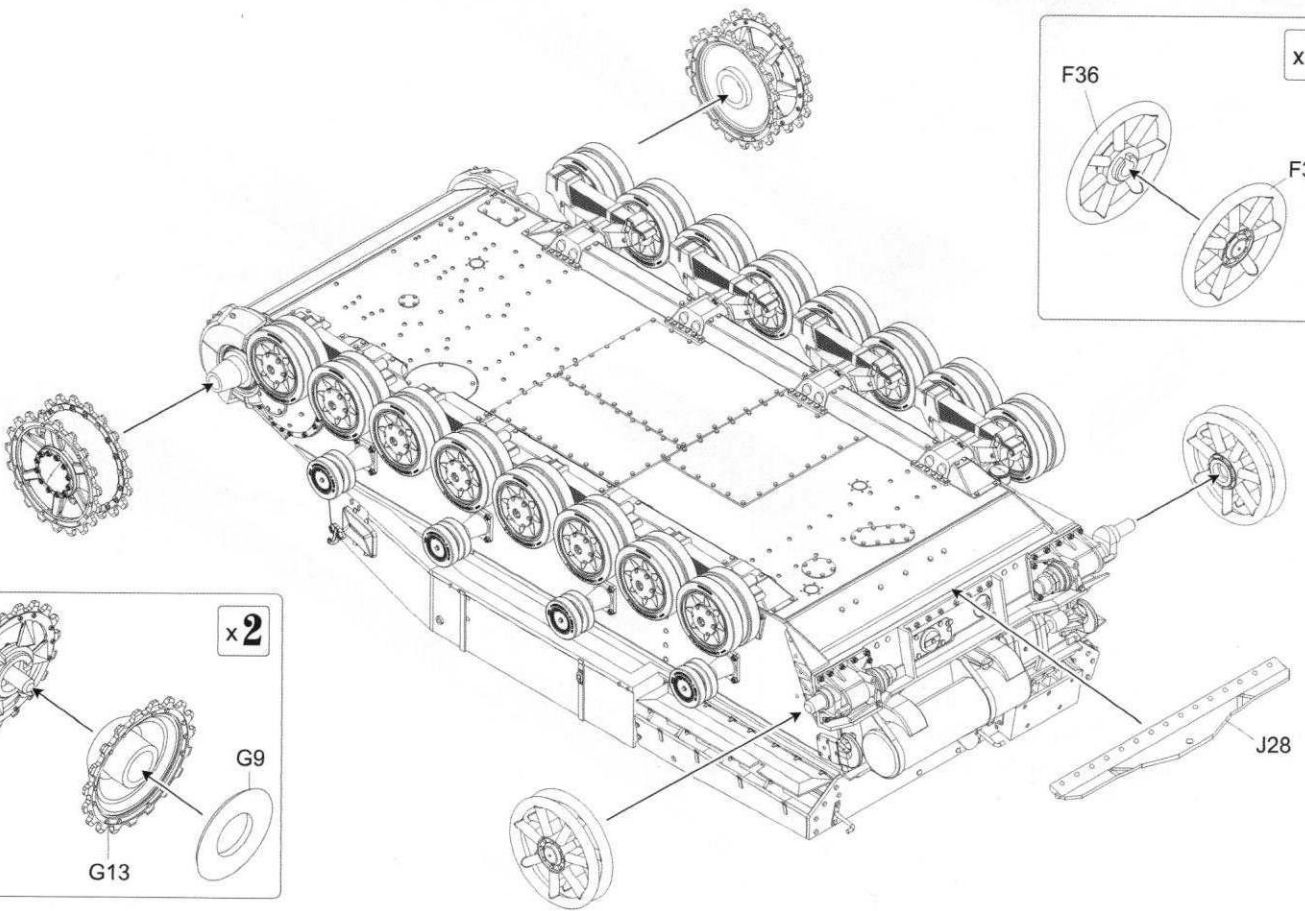

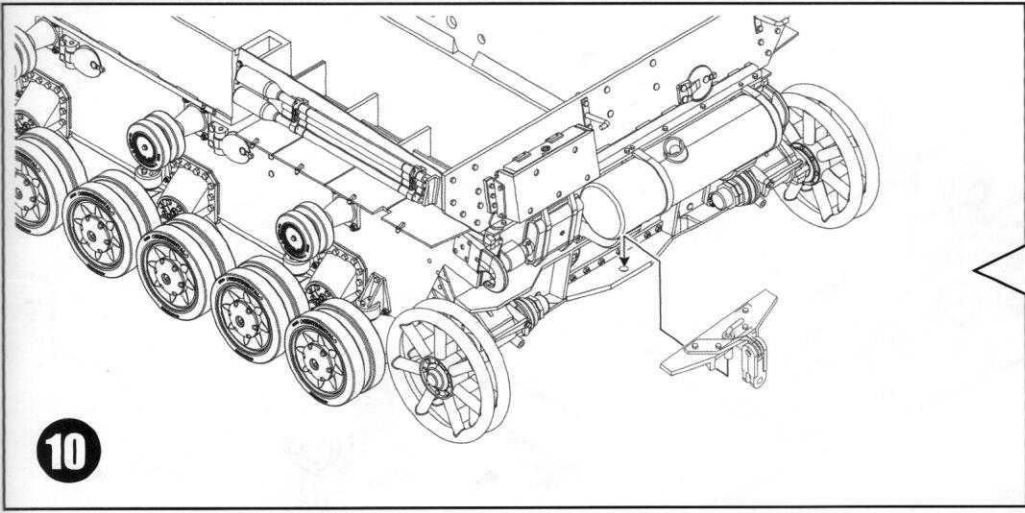

10

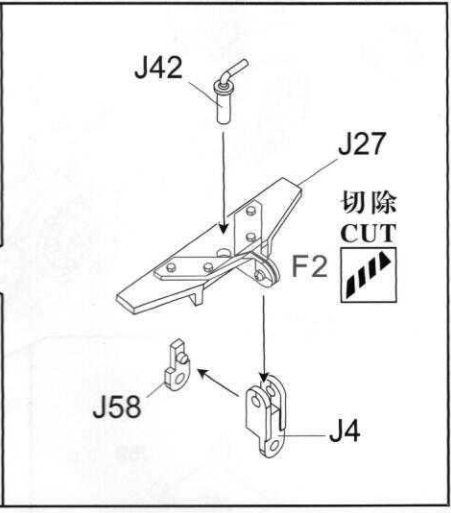

11

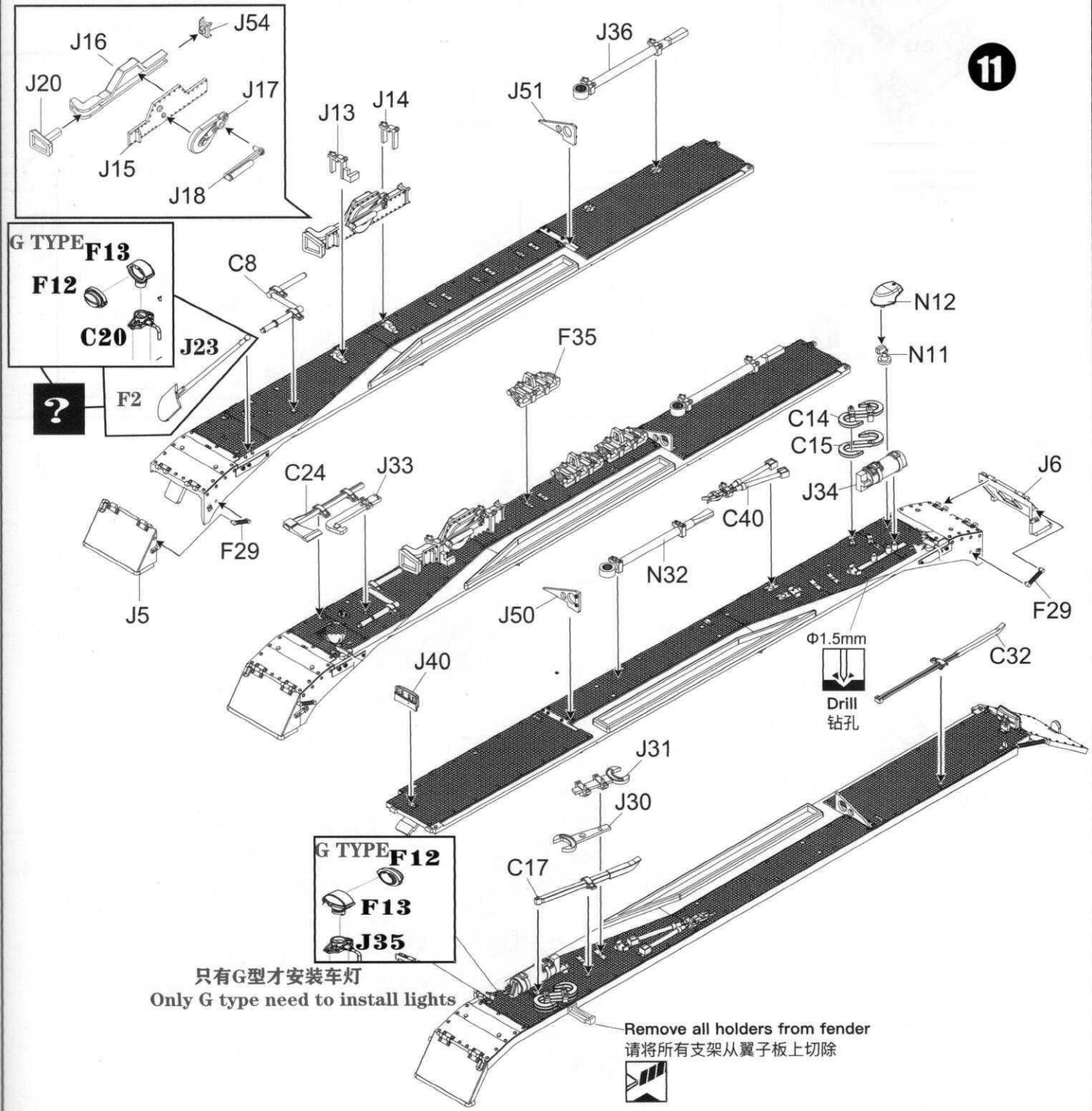

G TYPE F13
F12
C20
?

G TYPE F12
F13
J35

只有G型才安装车灯
Only G type need to install lights

Remove all holders from fender
请将所有支架从翼子板上切除



12

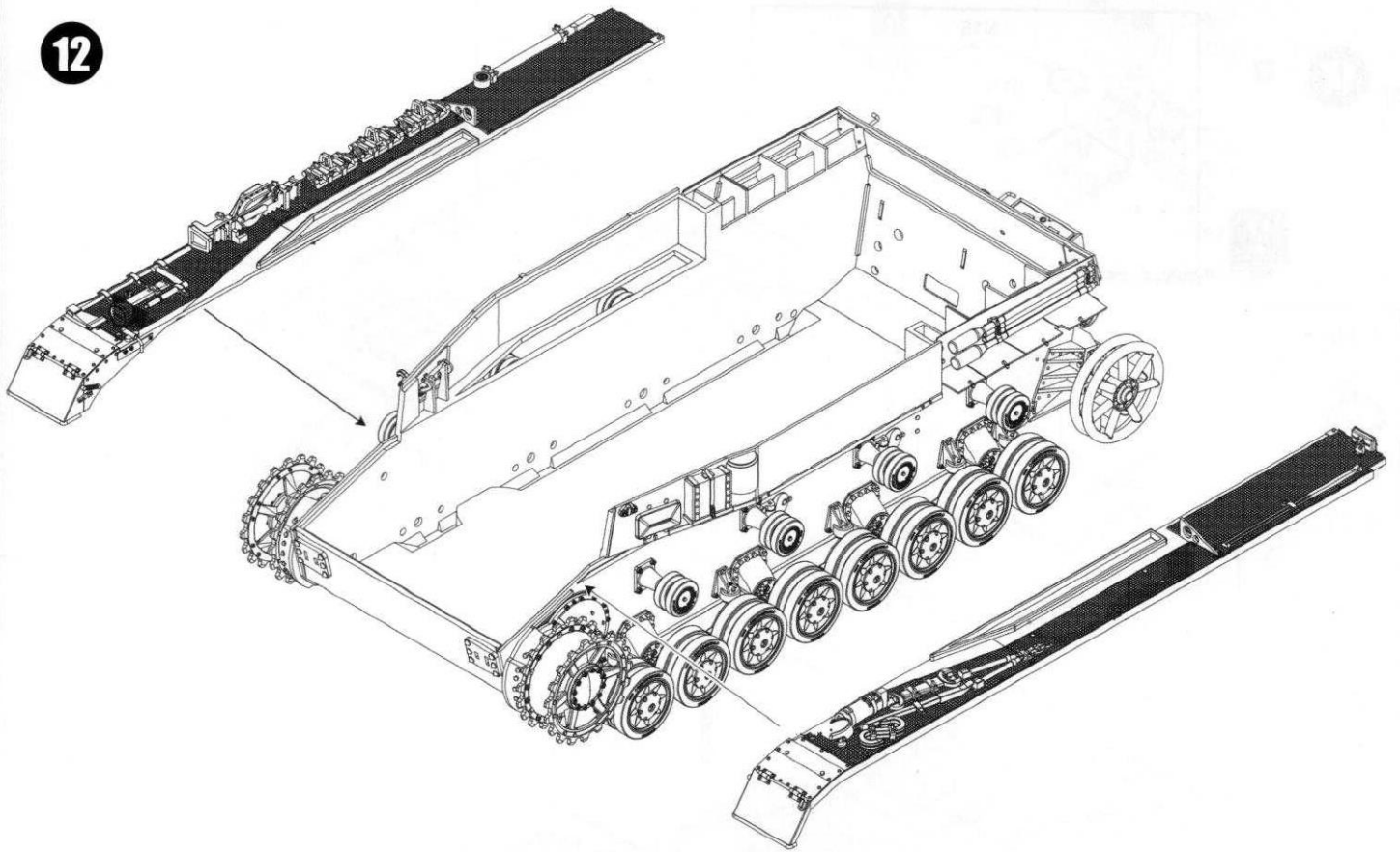

13

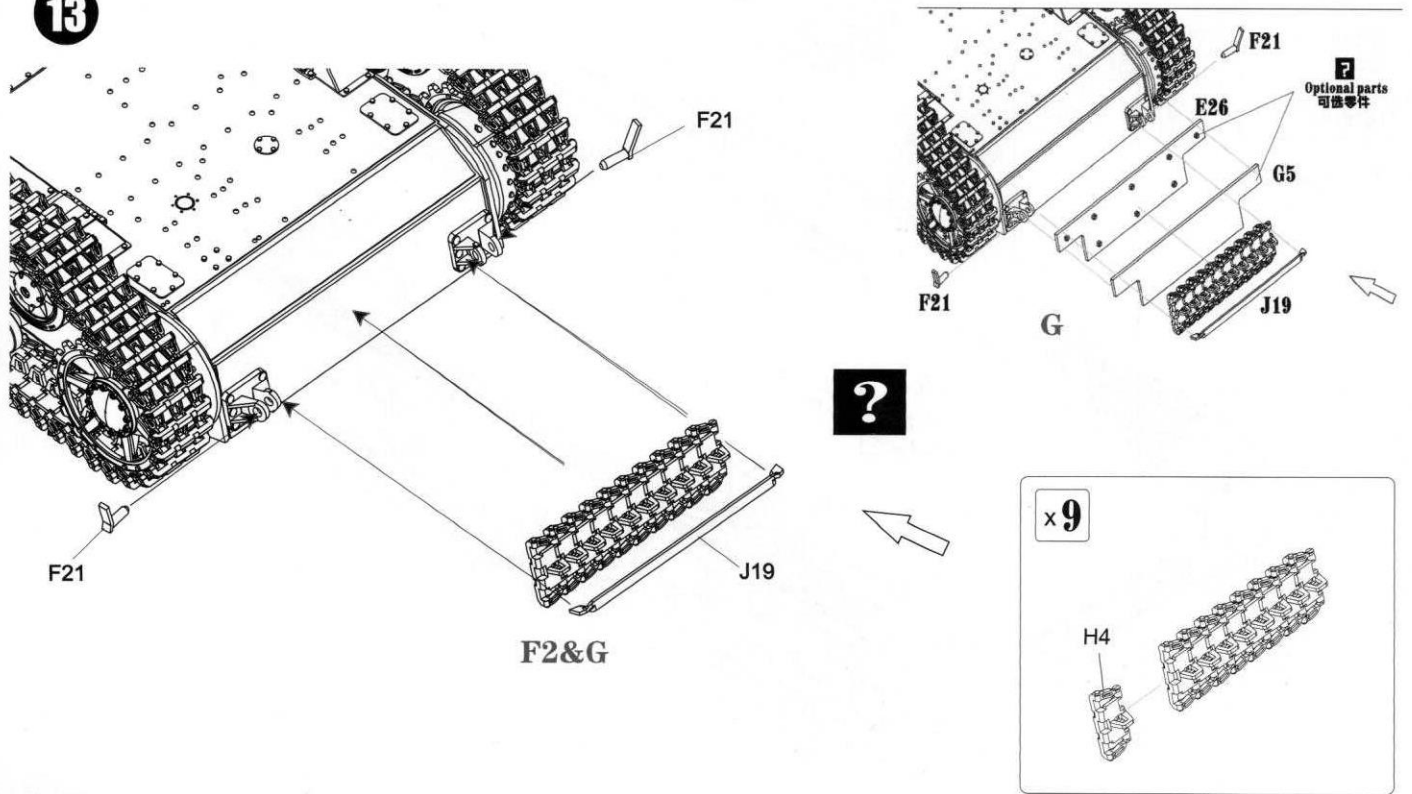

14

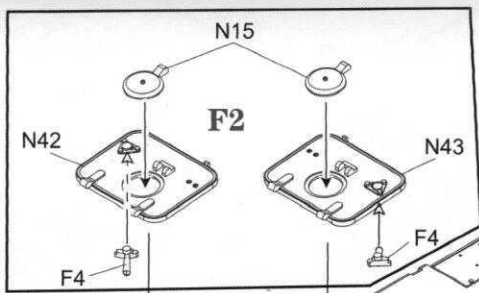

?

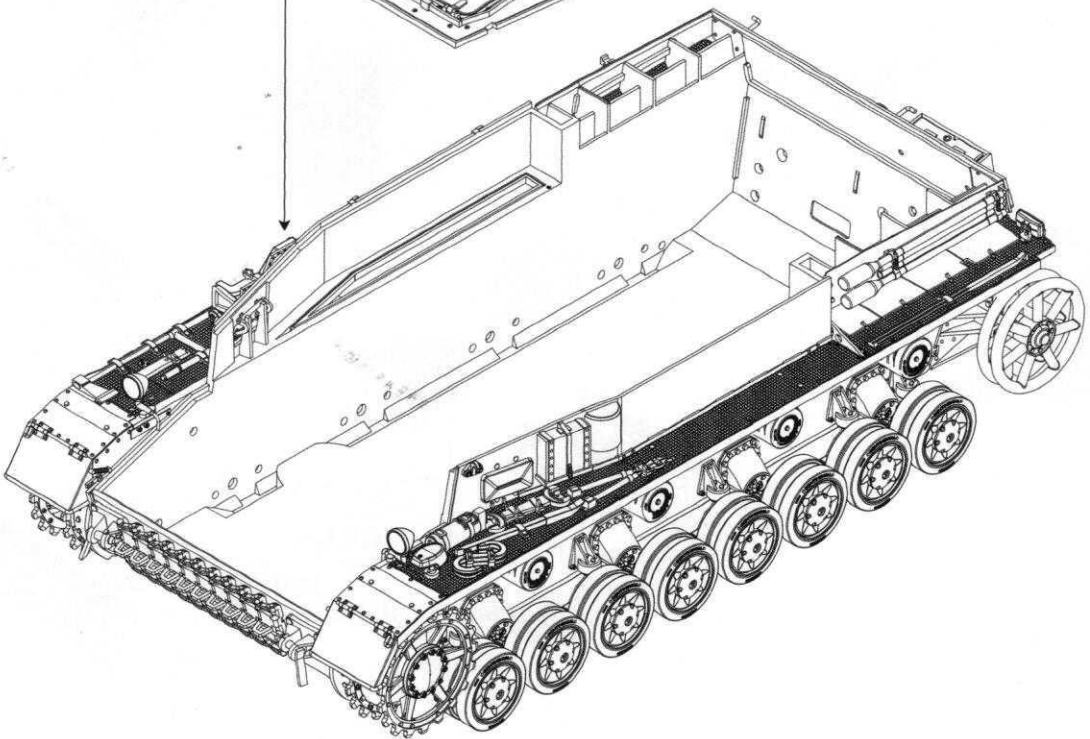
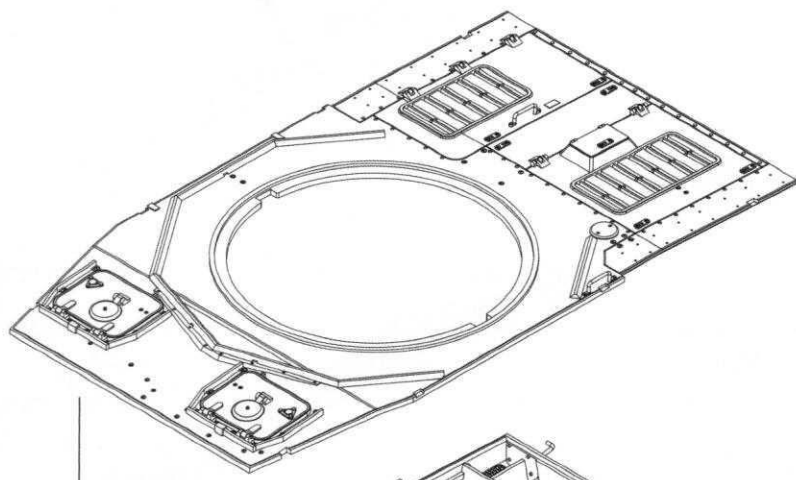
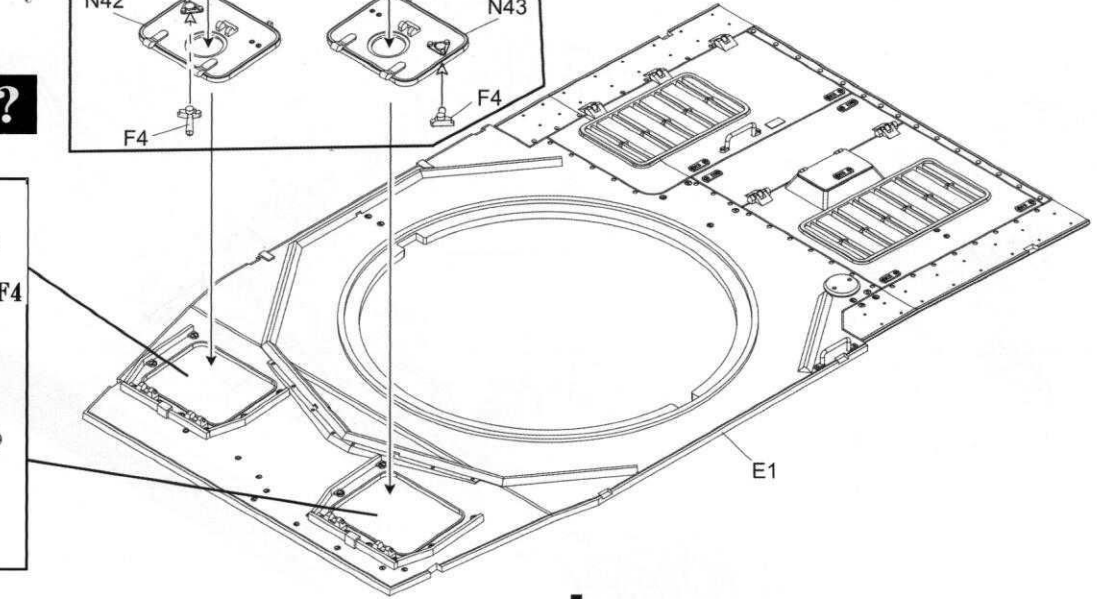
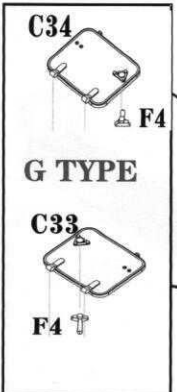

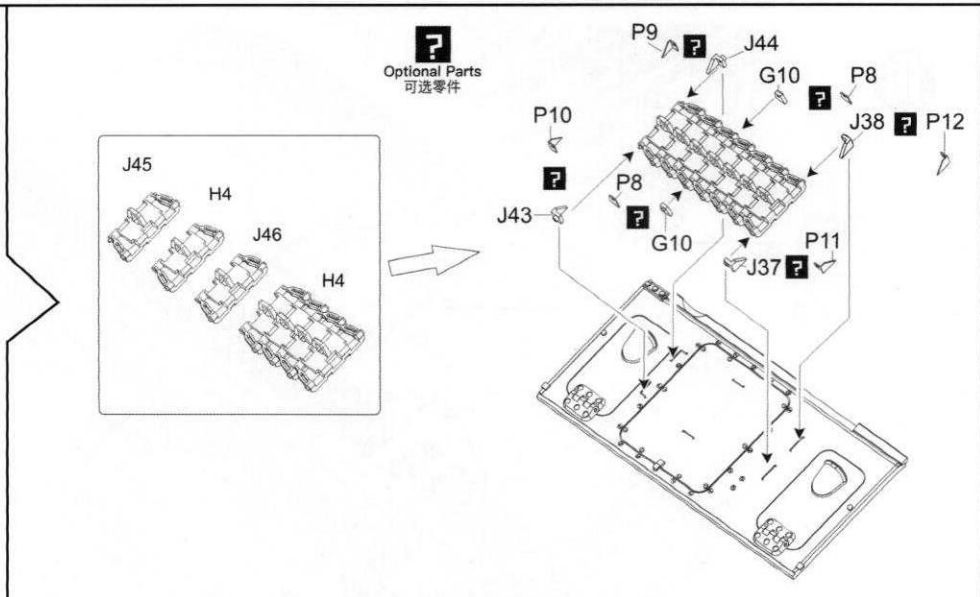
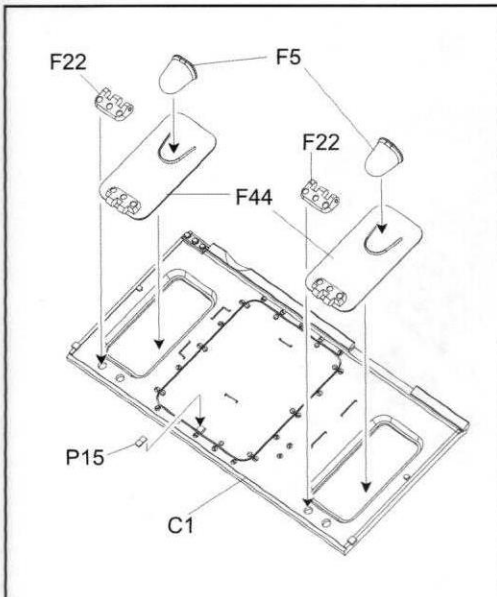

15

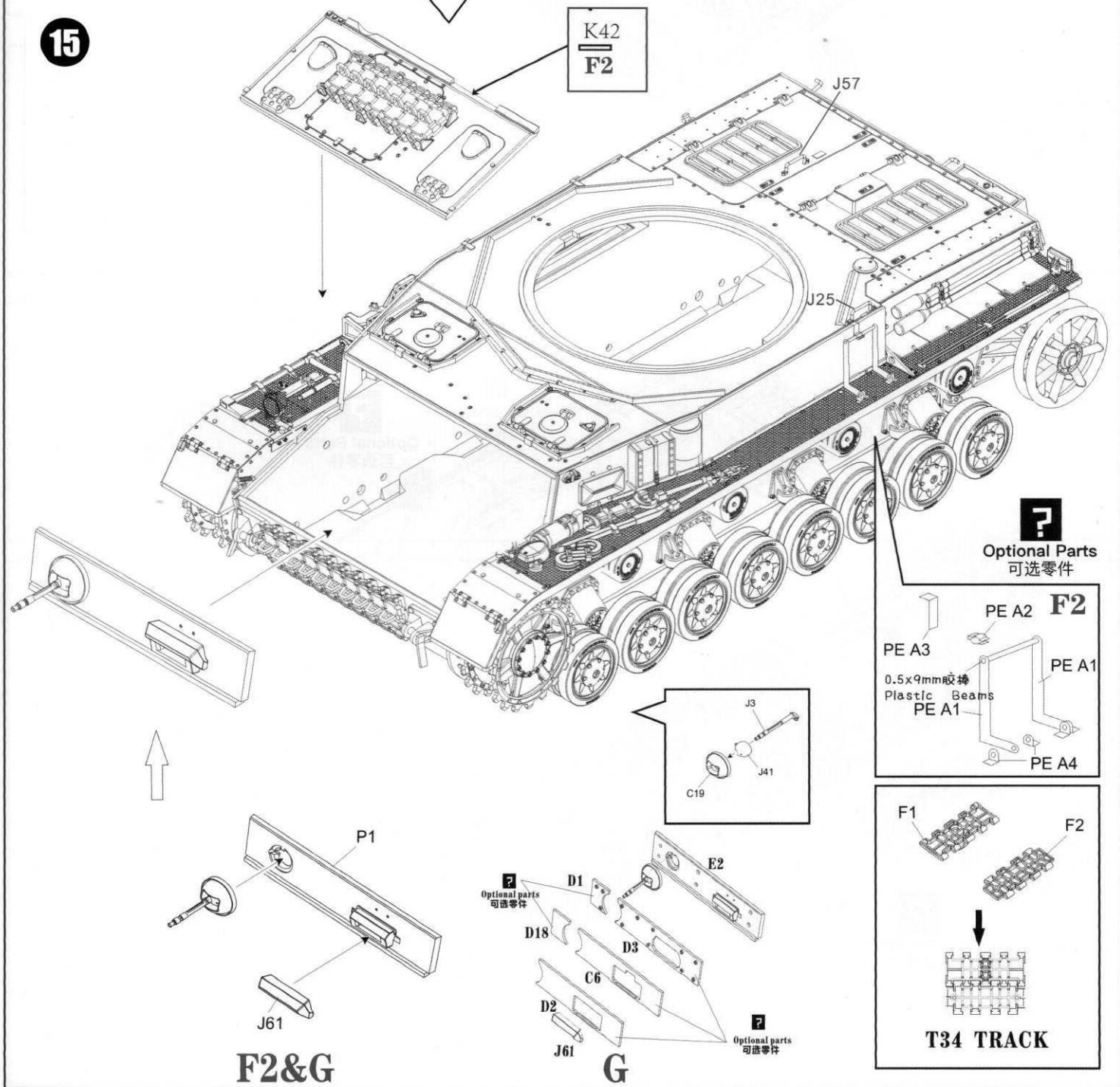

16

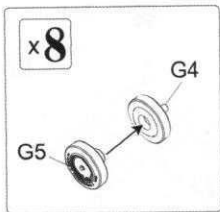

? H4 6 Pcs

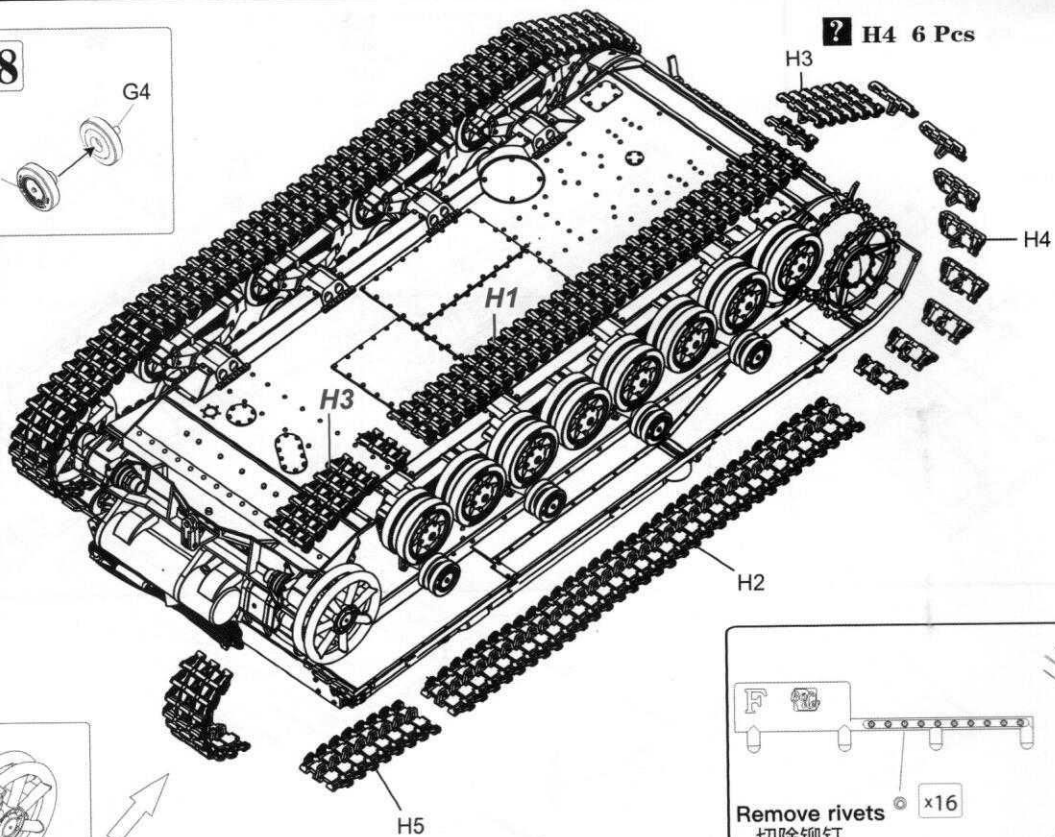

H4

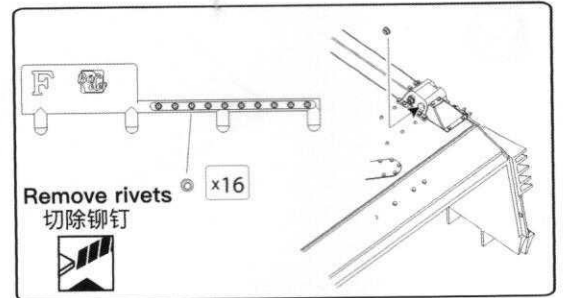
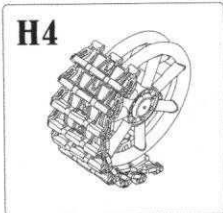

17

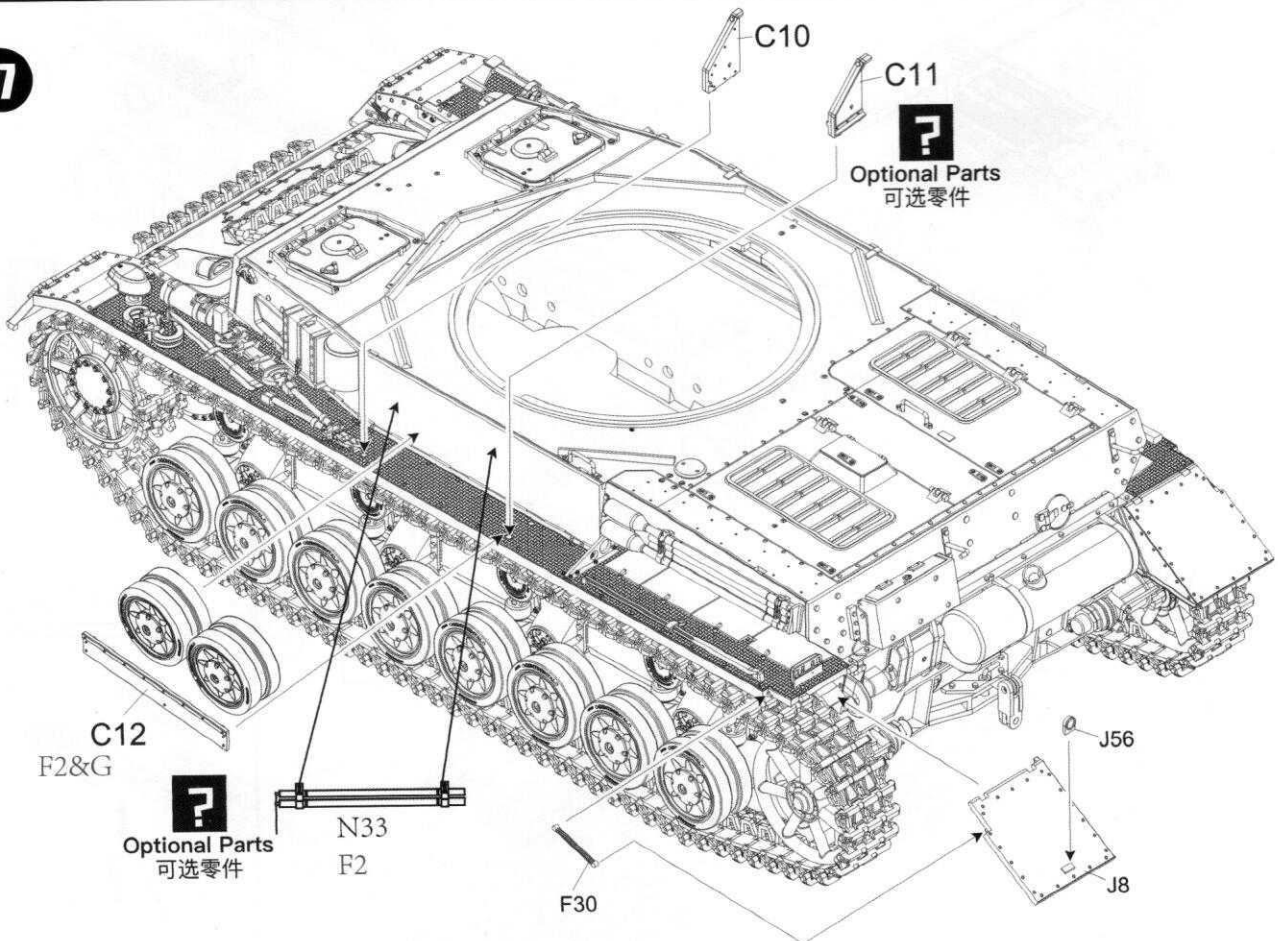

18

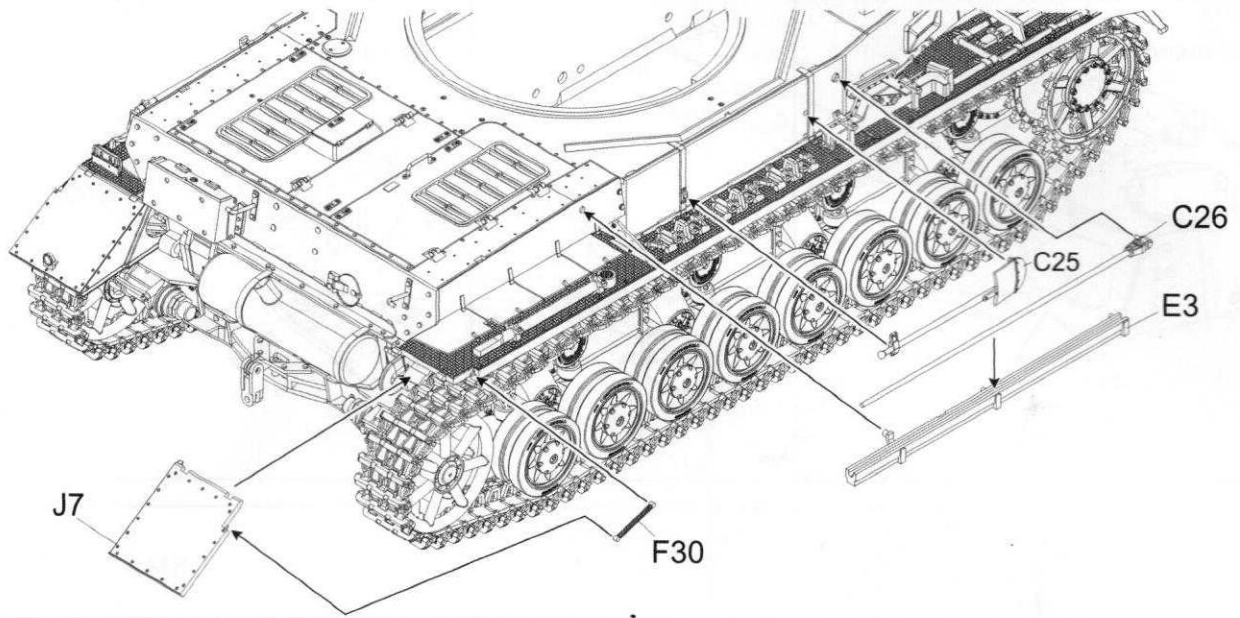

19

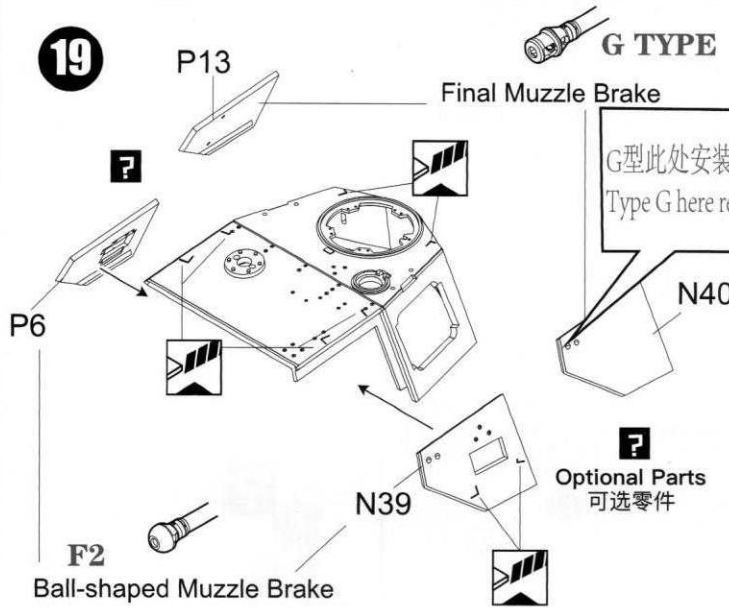

F2 Ball-shaped Muzzle Brake

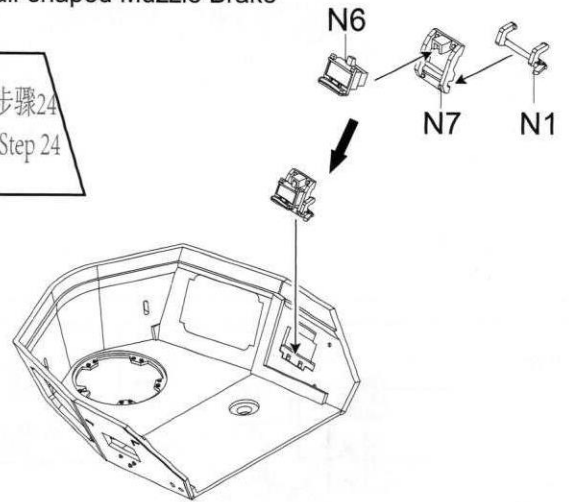

20

Ball-shaped Muzzle Brake

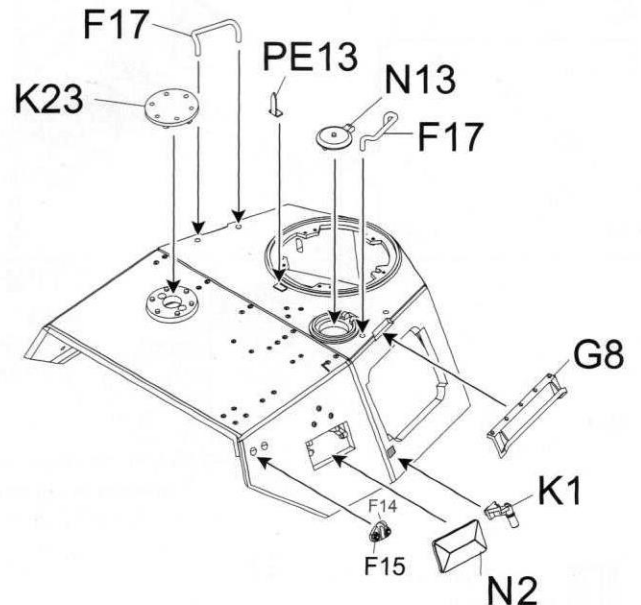
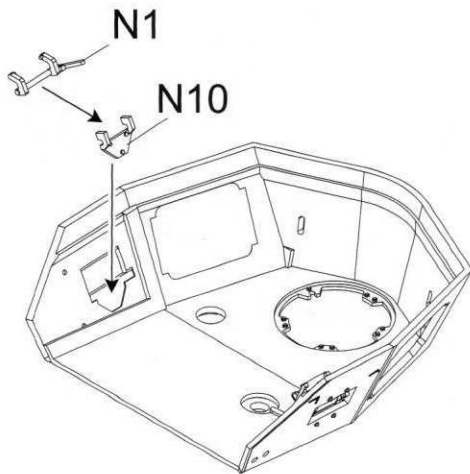

21

F2 Ball-shaped Muzzle Brake

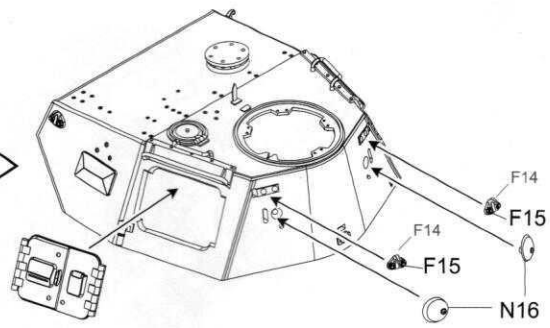
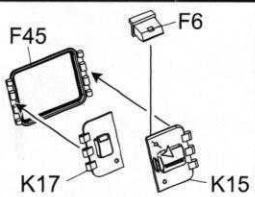
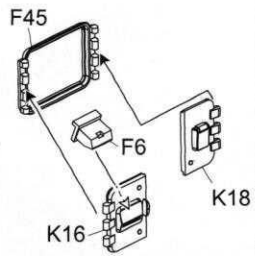
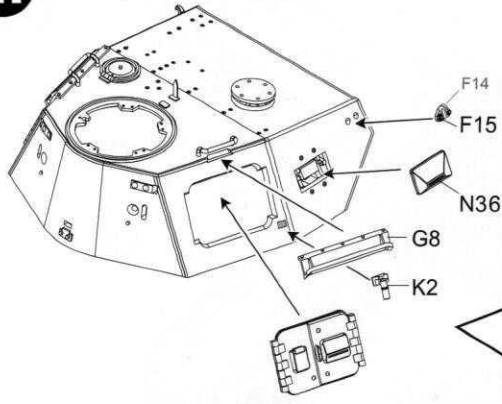

22

F2 Ball-shaped Muzzle Brake

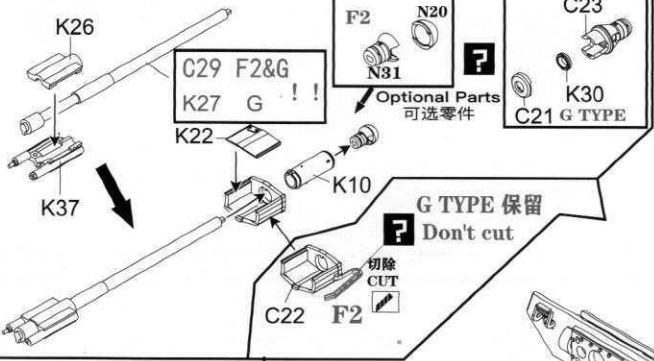
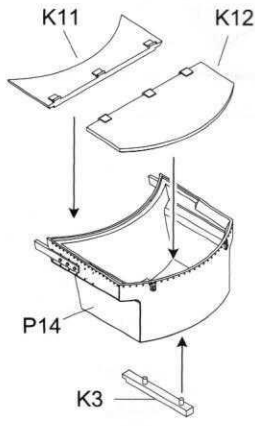
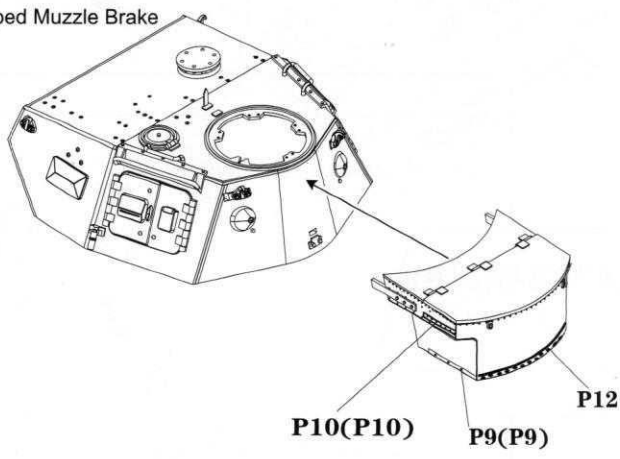

F2 Ball-shaped Muzzle Brake 23

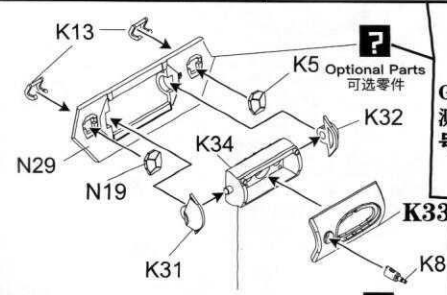
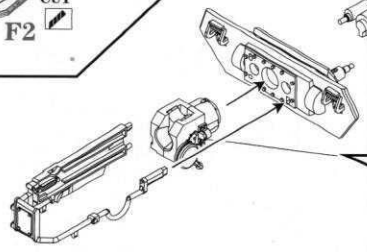
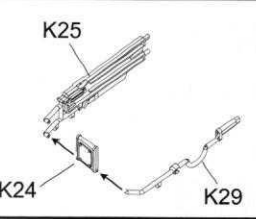
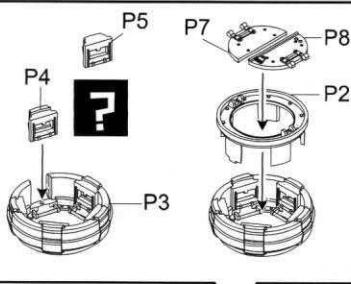

G TYPE K35

G型可以选择K35零件，只有一个观测窗，适用于哈尔科夫战役时期的四号G。

G type can choose K35 parts, only one observation window, suitable for PANZERIV G during the battle of Kharkov.

! Do not glue axle 轴不要涂胶

? Optional Parts 可选零件

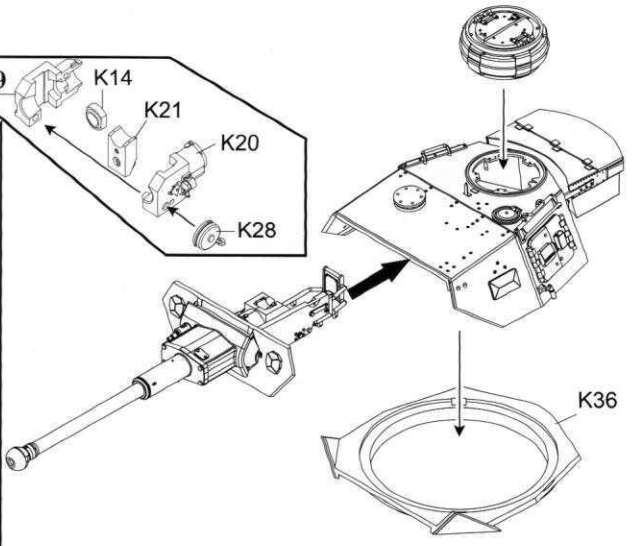

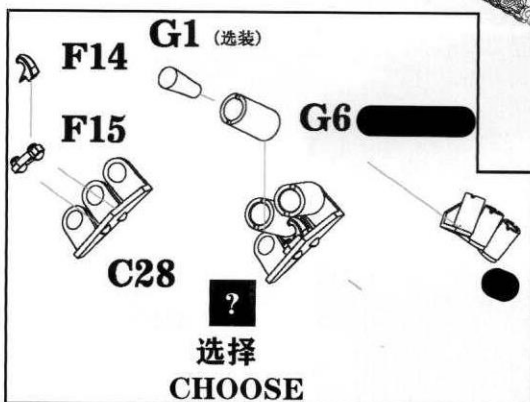
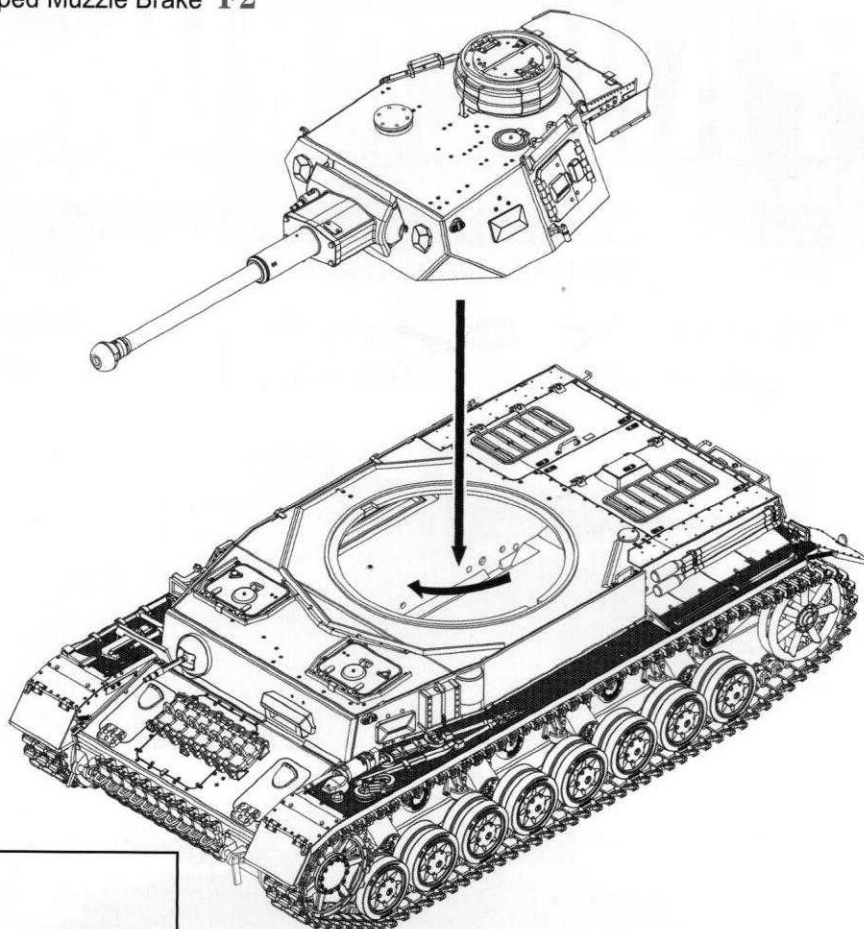



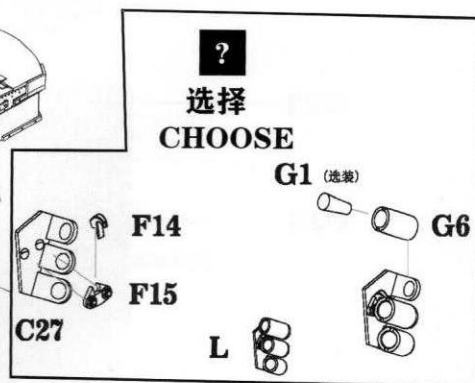
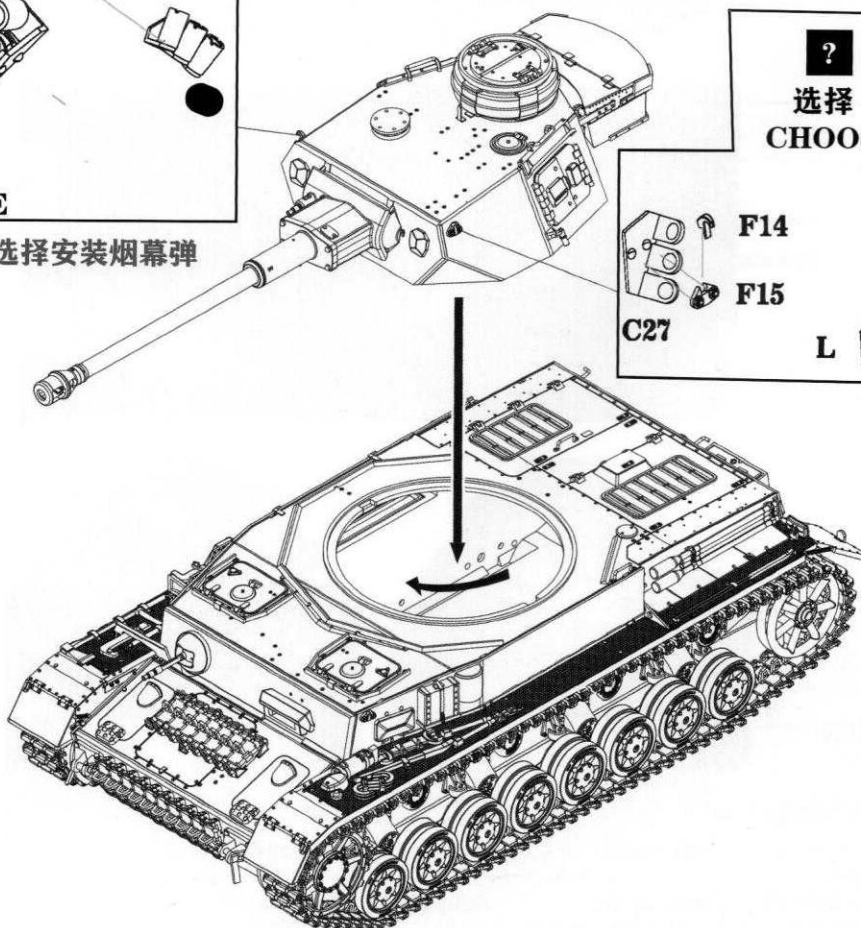

Final Muzzle Brake PANZER IV G TYPE

部分早中期的G型可以选择安装烟幕弹



PAINTING AND MARKING GUIDE

BORDER MODEL REF: BT-004 Panzer IV F2

 A.MIG-0033 Rubber & Tires	 A.MIG-0034 Rust Tracks	 A.MIG-0036 Old Wood	 A.MIG-0042 Old Rust
 A.MIG-0045 Gun Metal	 A.MIG-0016 Gelbraun		

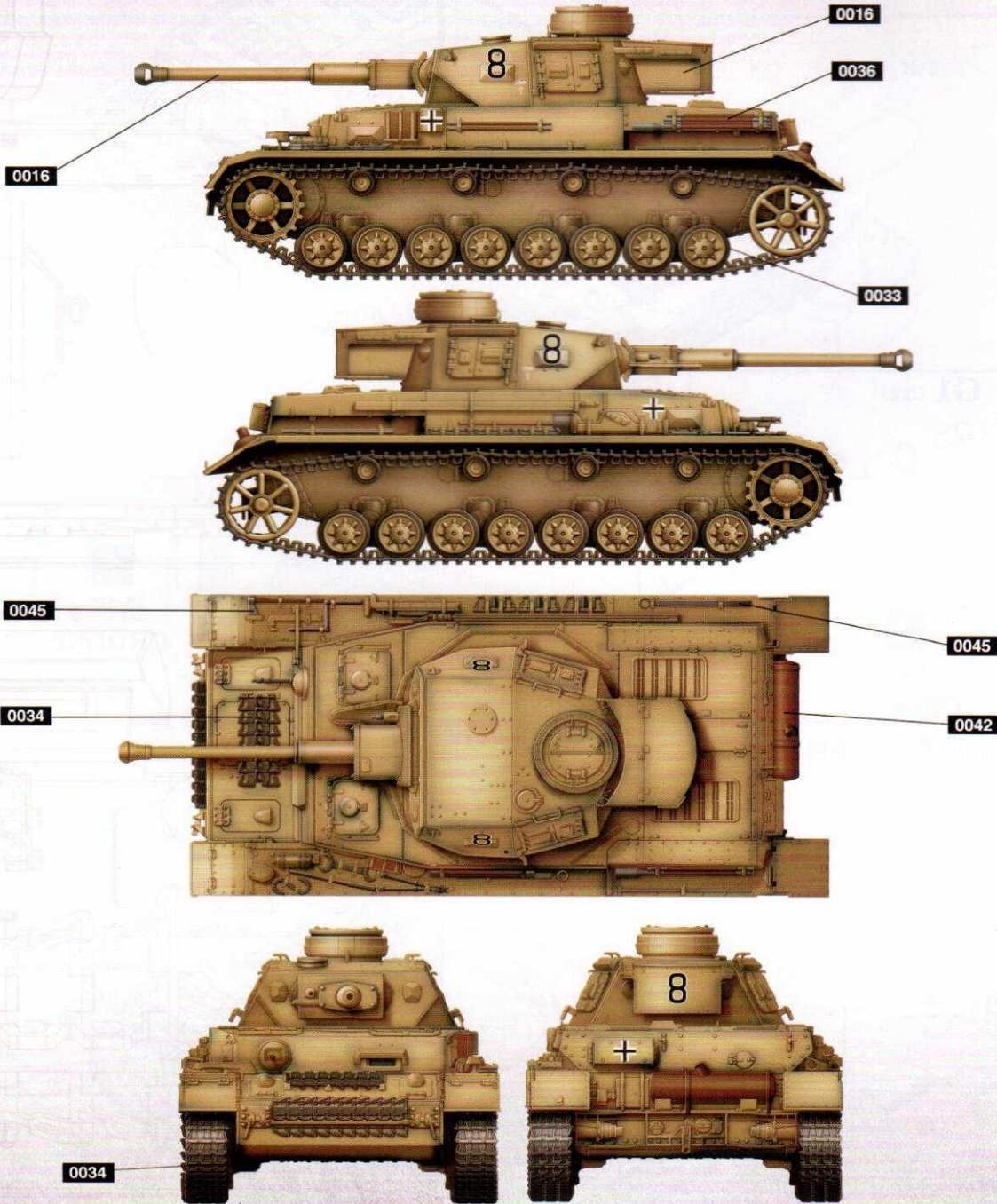

WEATHERING STEPS WITH AMMO PRODUCTS

- | | | | |
|---|--|--|---|
| 1 GENERAL WASH
A.MIG-1001 Afrika Korps Wash | 3 STREAKING
A.MIG-1201 Streaking Grime for DAK | 5 TRACKS WASH
A.MIG-1002 Tracks Wash | 7 MUD & SPLASHES
A.MIG-1702 Turned Earth A.MIG-1751 Dry Steppe |
| 2 FILTER
A.MIG-1505 Grey for Yellow Sand | 4 RAINMARKS
A.MIG-1258 Streakingbrusher Dust | 6 DUST
A.MIG-3003 North Africa Dust | 8 FUEL & OIL
A.MIG-1408 Fresh Engine Oil A.MIG-1409 Fuel Stains |

PAINTING AND MARKING GUIDE

BORDER MODEL REF: BT-004 Panzer IV F2 Pz.Ab.204

 A.MIG-0033 Rubber & Tires	 A.MIG-0034 Rust Tracks	 A.MIG-0037 New Wood	 A.MIG-0042 Old Rust
 A.MIG-0045 Gun Metal	 A.MIG-0002 Olivgrun opt.2	 A.MIG-0008 Dunkelgrau	

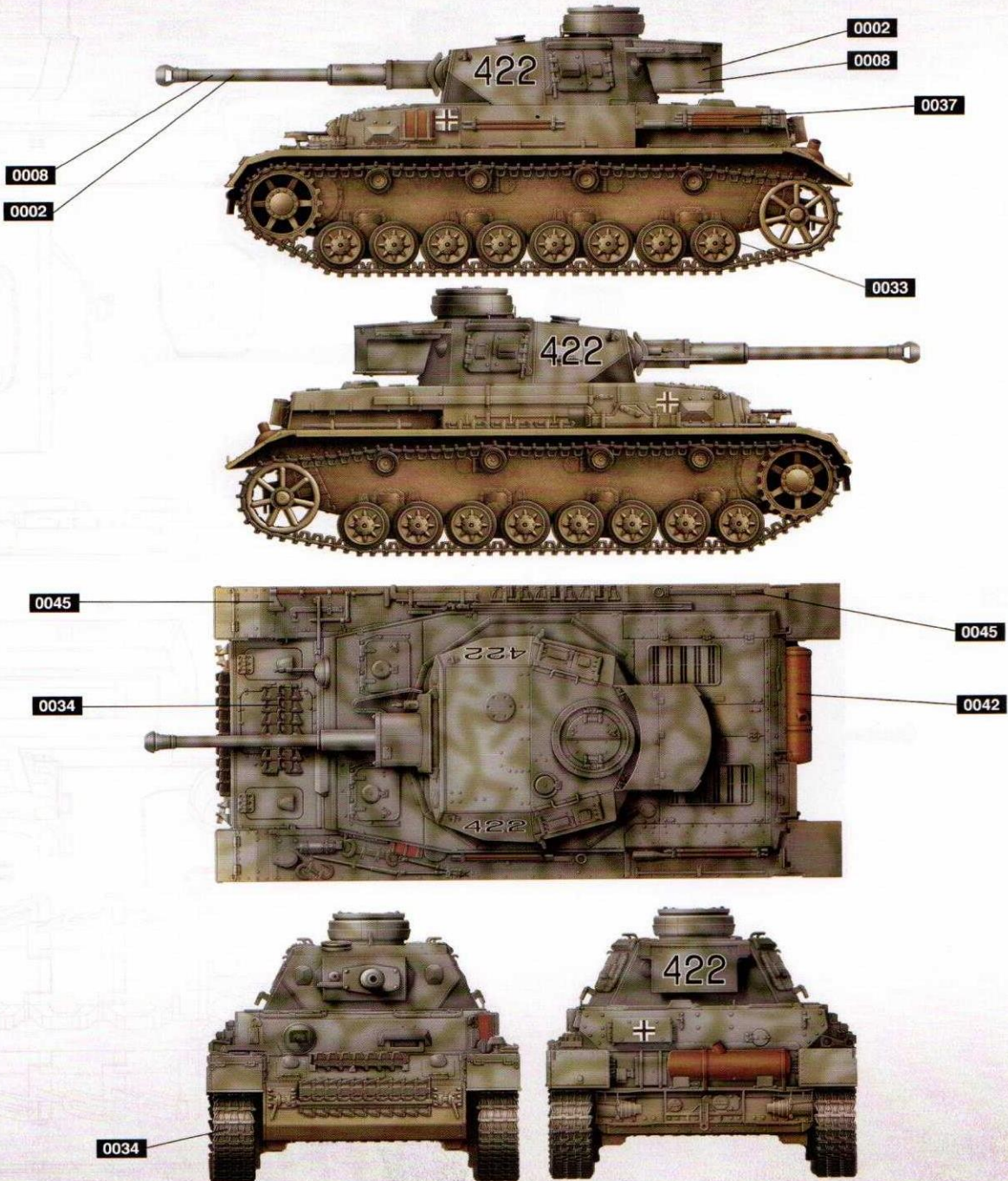

WEATHERING STEPS WITH AMMO PRODUCTS

1 GENERAL WASH

A.MIG-1006 Blue Wash for Panzer Grey

2 FILTER

A.MIG-1509 Blue for Dark Grey

3 STREAKING

A.MIG-1202 Streaking Grime for Panzer Grey

4 RAINMARKS

A.MIG-1208 Rainmarks Effects

5 TRACKS WASH

A.MIG-1002 Tracks Wash

6 DUST

A.MIG-3007 Dark Earth

7 MUD & SPLASHES







A.MIG-1705 Wet Mud A.MIG-1753 Turned Dirt

8 FUEL & OIL

A.MIG-1408 Fresh Engine Oil A.MIG-1409 Fuel Stains

PAINTING AND MARKING GUIDE

BORDER MODEL REF: BT-004 Panzer IV F2 Pz.Rg.36

 A.MIG-0033 Rubber & Tires	 A.MIG-0034 Rust Tracks	 A.MIG-0038 Light Wood	 A.MIG-0042 Old Rust
 A.MIG-0045 Gun Metal	 A.MIG-0010 Dunkelgelb (Mid War)	 A.MIG-0008 Dunkelgrau	

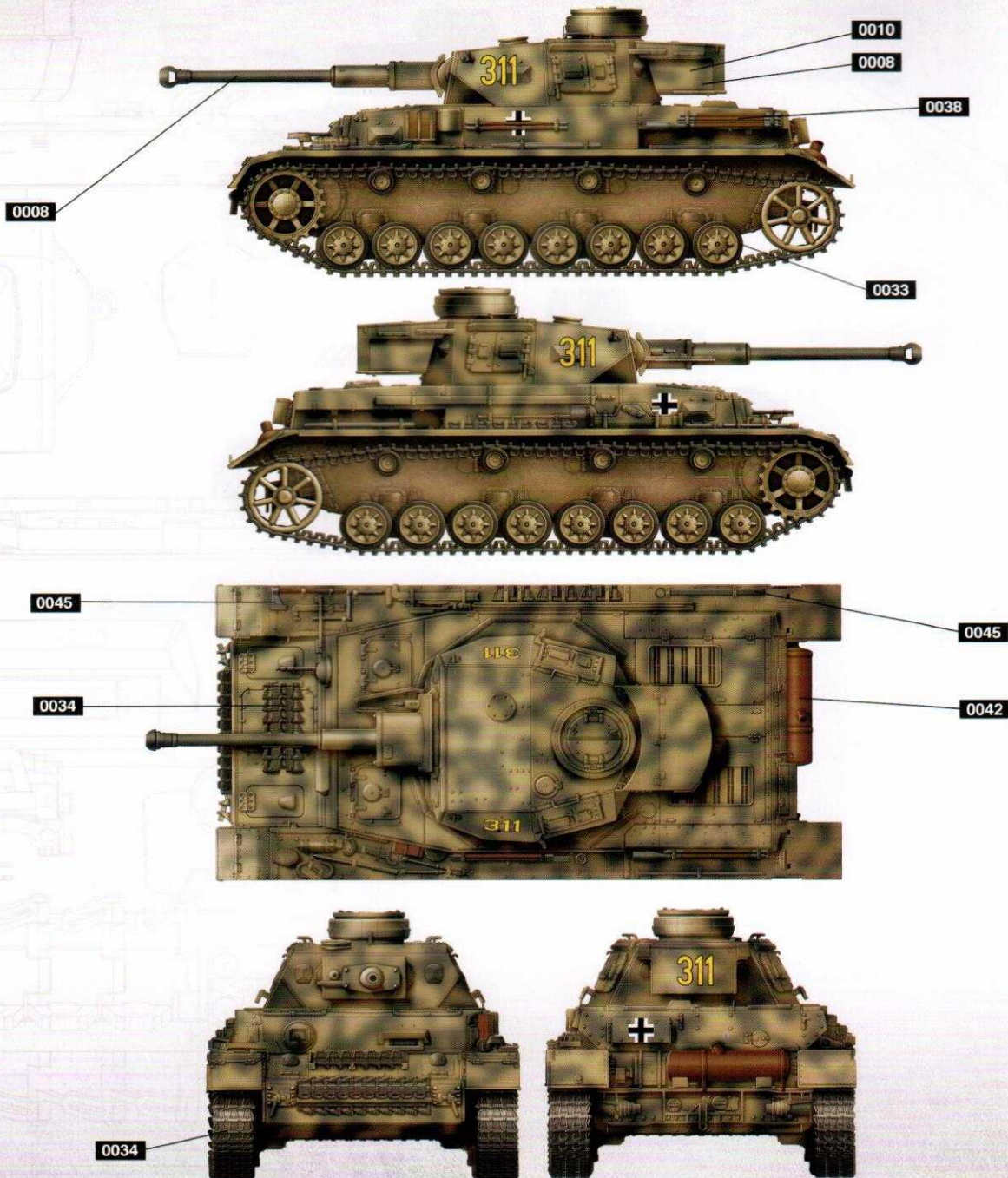

WEATHERING STEPS WITH AMMO PRODUCTS

1 GENERAL WASH

A.MIG-1000 Brown Wash for German Dark Yellow

2 FILTER

A.MIG-1510 Tan for 3 Tone Camo

3 STREAKING

A.MIG-1256 Streakingbrusher Green-Grey Grime

4 TRACKS WASH

A.MIG-1002 Tracks Wash

5 RUST

A.MIG-1004 Light Rust Wash

6 DUST

A.MIG-3004 Europe Earth

7 MUD & SPLASHES





A.MIG-1704 Heavy Earth A.MIG-1753 Turned Dirt

8 FUEL & OIL

A.MIG-1409 Fuel Stains A.MIG-1408 Fresh Engine Oil

PAINTING AND MARKING GUIDE

BORDER MODEL REF: BT-004 Panzer IV G early Southern Russia, spring 1942

 A.MIG-0033 Rubber & Tires	 A.MIG-0034 Rust Tracks	 A.MIG-0036 Old Wood	 A.MIG-0042 Old Rust
 A.MIG-0045 Gun Metal	 A.MIG-0010 Dunkelgelb (Mid War)		

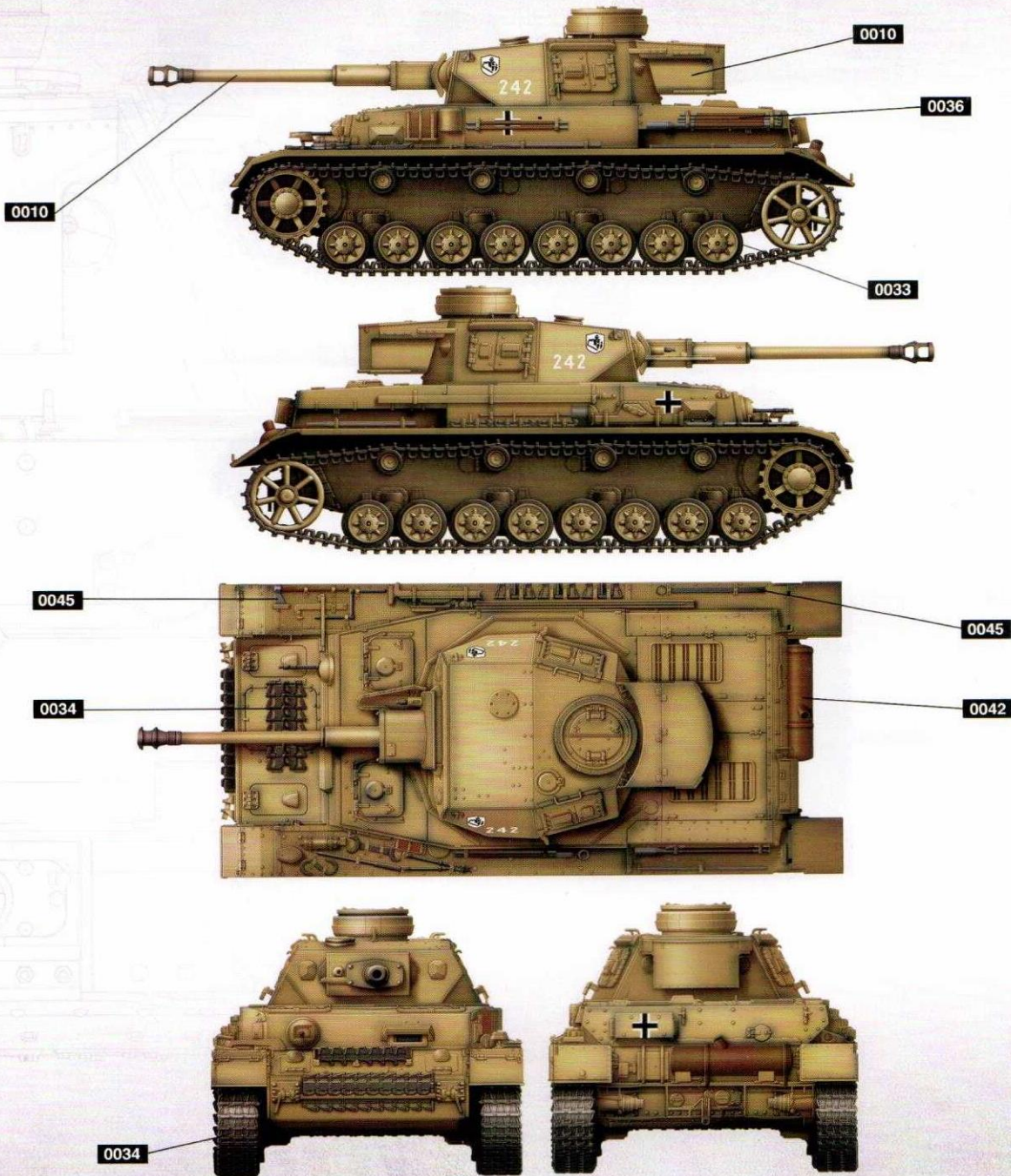







WEATHERING STEPS WITH AMMO PRODUCTS

- | | | | |
|---|--|---|--|
| 1 GENERAL WASH
A.MIG-1000 Brown Wash for German Dark Yellow | 3 STREAKING
A.MIG-1203 Streaking Grime | 5 RUST
A.MIG-1254 Streakingbrusher Rust | 7 MUD & SPLASHES
A.MIG-1703 Moist Ground A.MIG-1752 Loose Ground |
| 2 FILTER
A.MIG-1511 Brown for Dark Yellow | 4 TRACKS WASH
A.MIG-1002 Tracks Wash | 6 DUST
A.MIG-3011 Airfield Dust | 8 FUEL & OIL
A.MIG-1409 Fuel Stains A.MIG-1408 Fresh Engine Oil |

PAINTING AND MARKING GUIDE

BORDER MODEL REF: BT-004 Panzer IV G early Tunisia 1943

 A.MIG-0033 Rubber & Tires	 A.MIG-0034 Rust Tracks	 A.MIG-0037 New Wood	 A.MIG-0042 Old Rust
 A.MIG-0045 Gun Metal	 A.MIG-0008 Dunkelgrau	 A.MIG-0016 Gelbbraun	

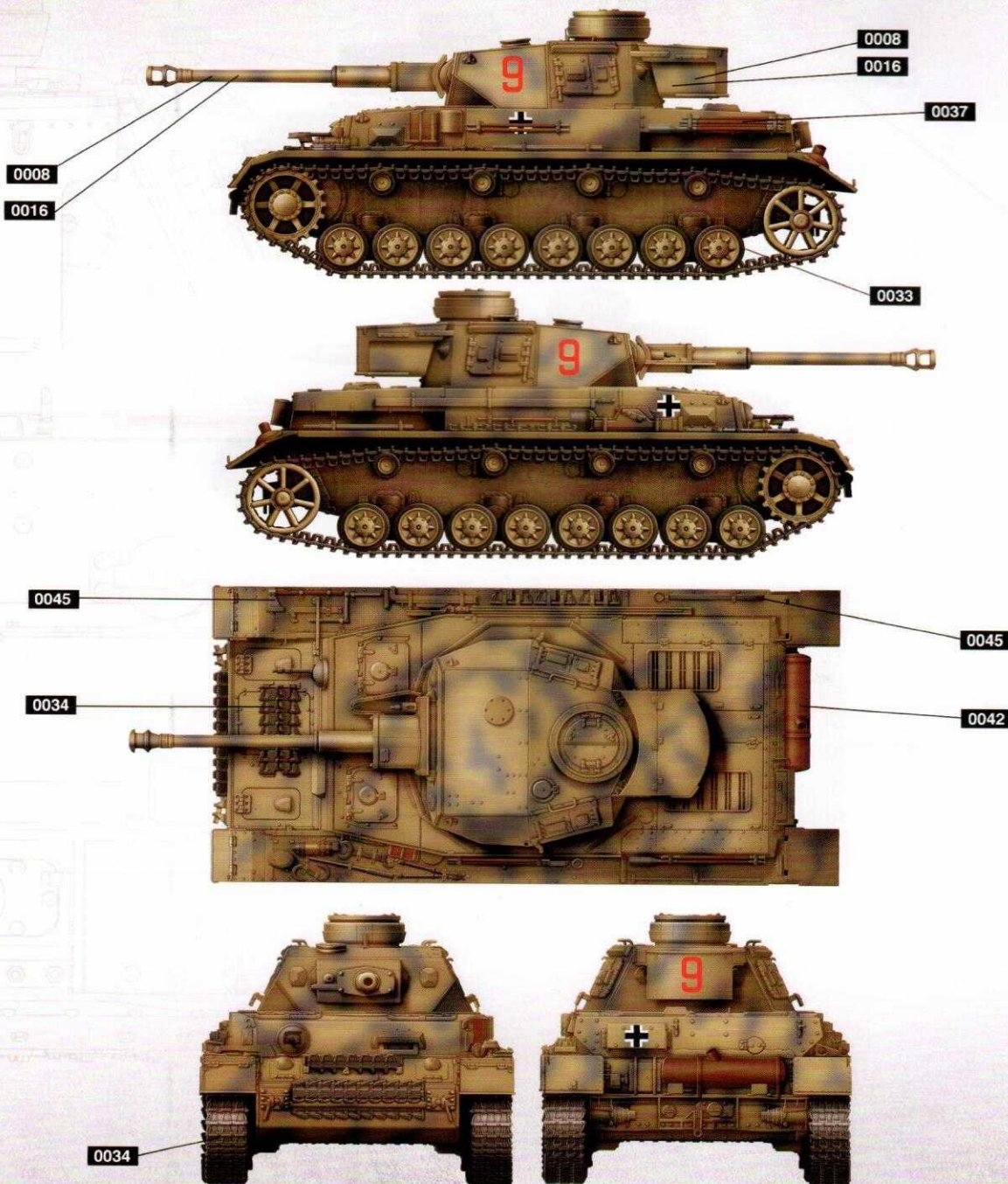

WEATHERING STEPS WITH AMMO PRODUCTS

1 GENERAL WASH

A.MIG-1001 Afrika Korps Wash

2 FILTER

A.MIG-1504 Brown for Desert Yellow

3 STREAKING

A.MIG-1251 Streakingbrusher Cold Dirty Grey

4 RAINMARKS

A.MIG-1208 Rainmarks Effect

5 TRACKS WASH

A.MIG-1002 Tracks Wash

6 DUST

A.MIG-3012 Sand

7 MUD & SPLASHES







A.MIG-1702 Turned Earth A.MIG-1751 Dry Steppe

8 FUEL & OIL

A.MIG-1409 Fuel Stains A.MIG-1408 Fresh Engine Oil

PAINTING AND MARKING GUIDE

BORDER MODEL REF: BT-004 Panzer IV G Leibstandarte SS AH

 A.MIG-0033 Rubber & Tires	 A.MIG-0034 Rust Tracks	 A.MIG-0038 Light Wood	 A.MIG-0042 Old Rust
 A.MIG-0045 Gun Metal	 A.MIG-0008 Dunkelgrau	 A.MIG-0010 Dunkelgelb (MID WAR)	

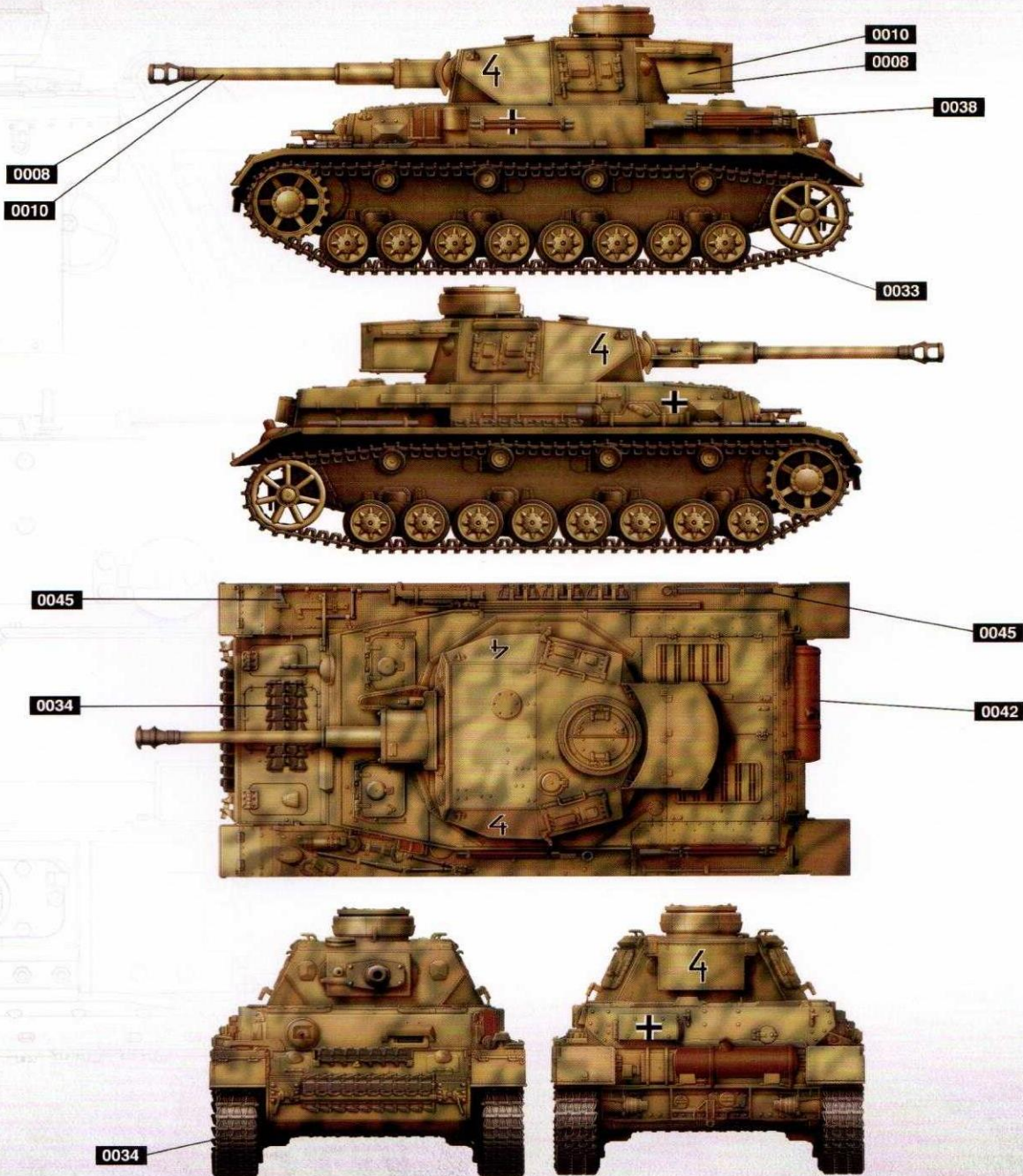

WEATHERING STEPS WITH AMMO PRODUCTS

- | | | | |
|---|---|--|--|
| 1 GENERAL WASH
A.MIG-1000 Brown Wash for German Dark Yellow | 3 STREAKING
A.MIG-1253 Streakingbrusher Grime | 5 RUST
A.MIG-1204 Streaking Rust | 7 MUD & SPLASHES
A.MIG-1704 Heavy Earth A.MIG-1753 Turned Dirt |
| 2 FILTER
A.MIG-1503 Ochre for Light Sand | 4 TRACKS WASH
A.MIG-1002 Tracks Wash | 6 DUST
A.MIG-3013 Rubble | 8 FUEL & OIL
A.MIG-1409 Fuel Stains A.MIG-1408 Fresh Engine Oil |

