

# IAI Seascan 1124

1172

IDM72100

IsraCast 

MULTIMEDIA KITS

Designed by Alexey Dashinsky

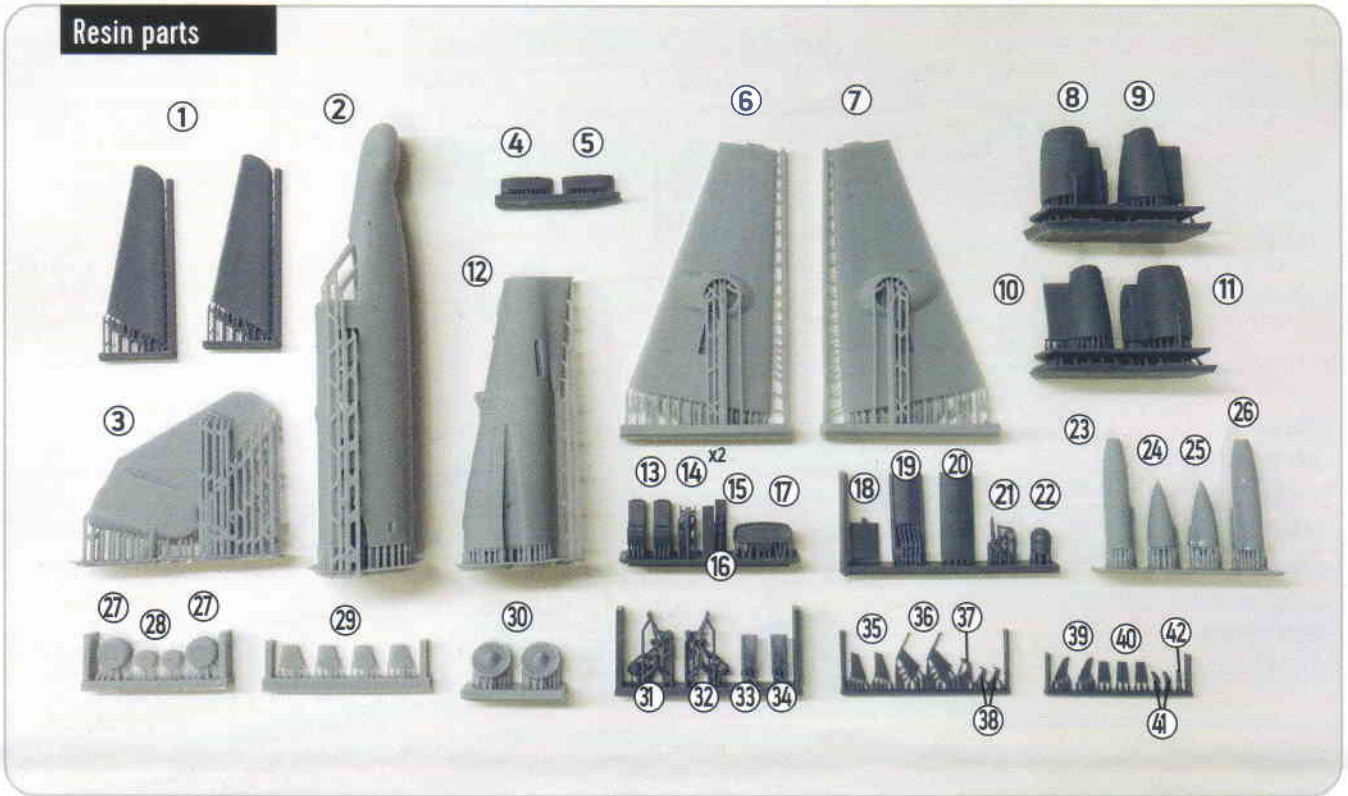

**Note:** The kit is a 3D design kit. Check the parts carefully when disconnecting them from their supports. Some are very gentle and fragile. Large parts like wings should be examined and may need soft sanding to eliminate a few printing lines. Some adjustments will need to be made during the modeling. Always dry fit each part before gluing it, and sand the edges if needed for perfect fitting. The clear resin parts CAN be glued with cyanoacrylate glue.

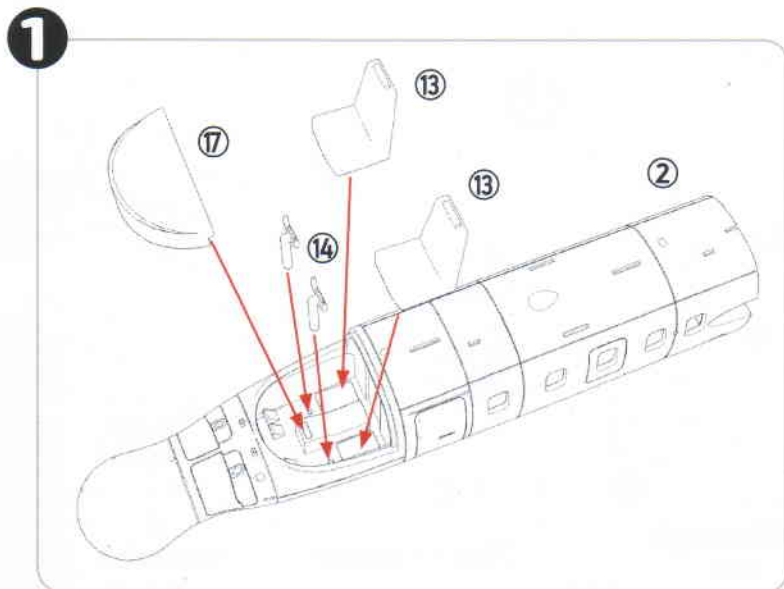

Paint the cockpit grey FS 36231. The inner frames are light tan. The controls [parts #14] and dashboard [part #17] are matt black. Use decal #50 for the instrument panel and attach it inside the cockpit. The seats [parts #13] are blue.



2

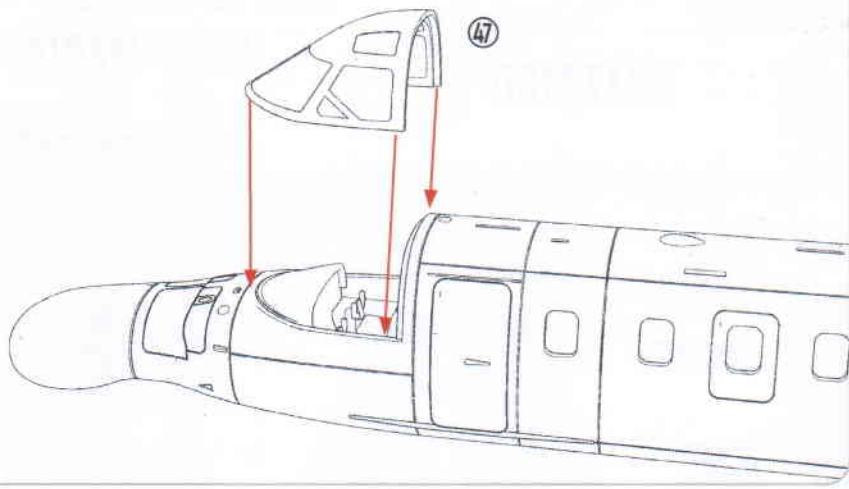

Attach part #45. It can be glue with Cyanoacrilate glue.

3

Attach part #43 inside the fuselage. Do a dry fit first and slowly glue it in. Push the parts toward the inner fuselage.

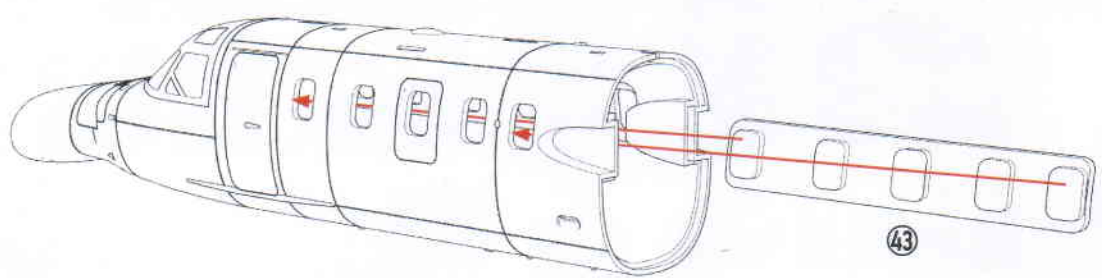

4

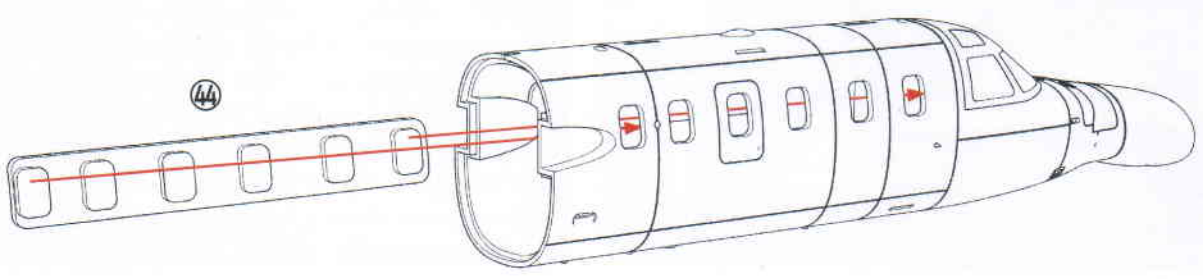

5

**FLIR Installation**

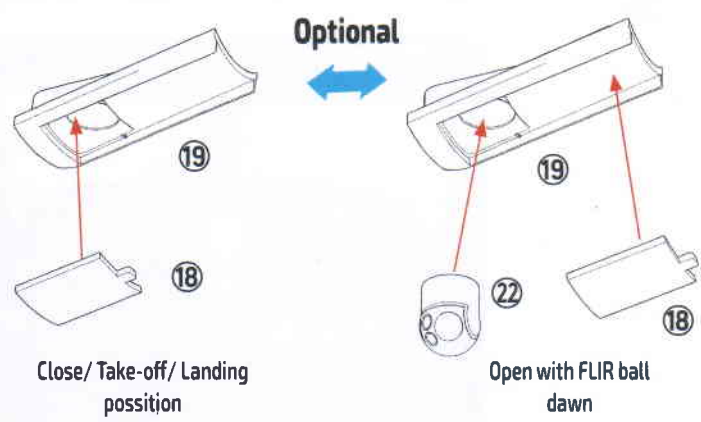

6

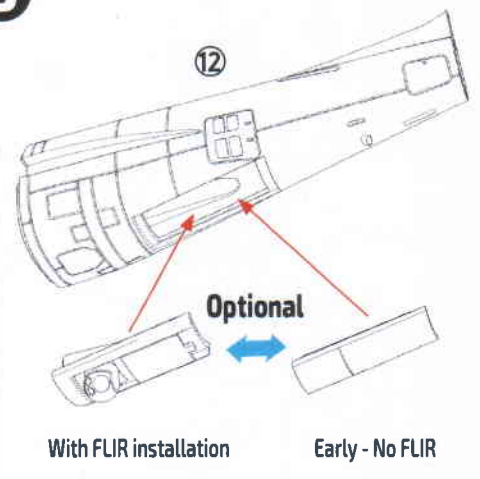

7

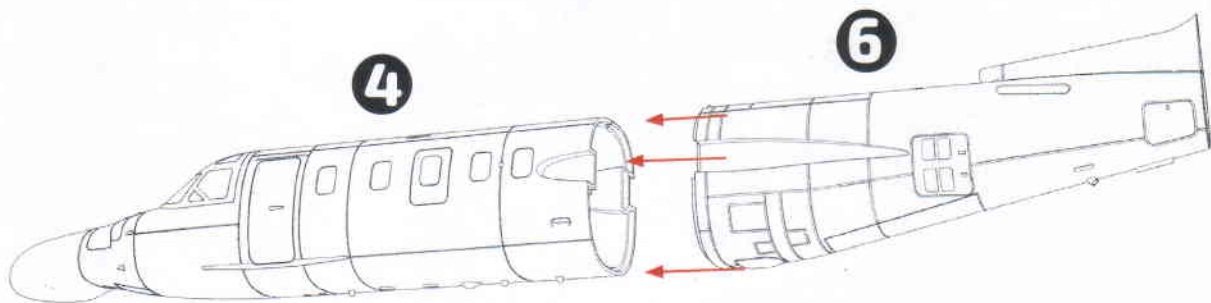

8

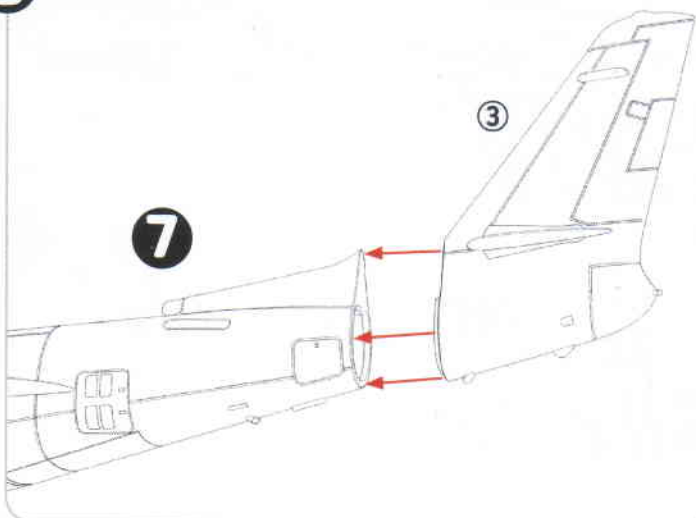

9

Left engine

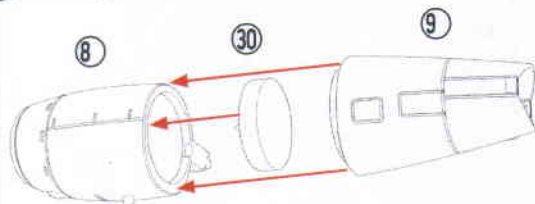

10

Right engine

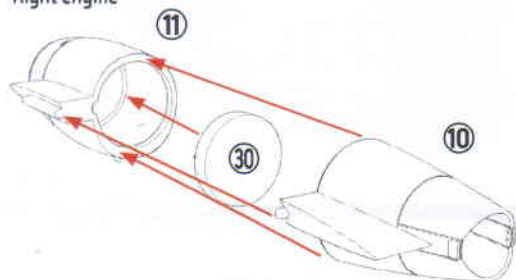

11

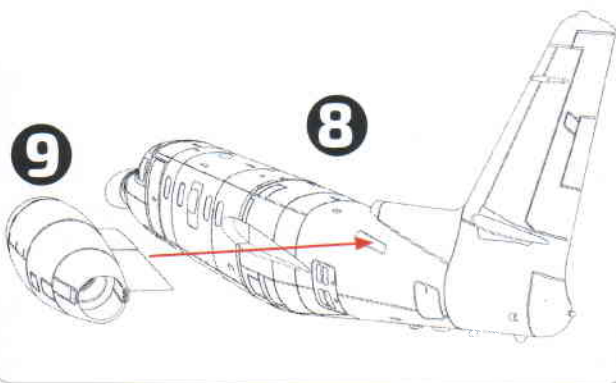

12

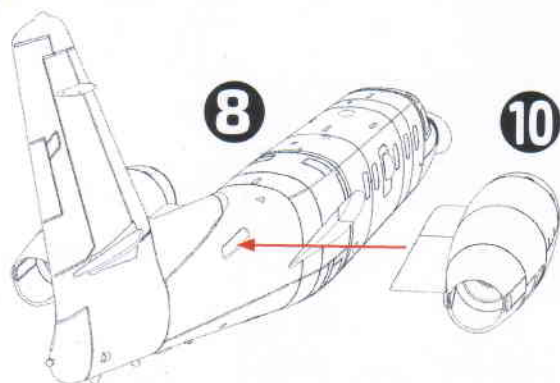

13

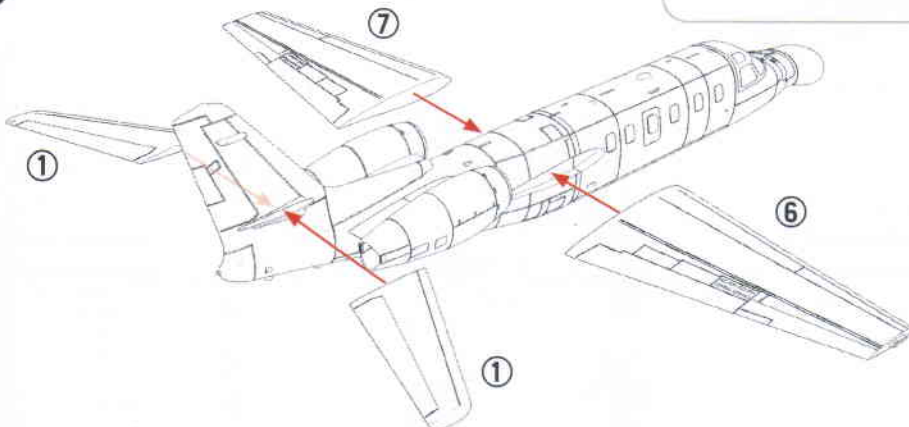

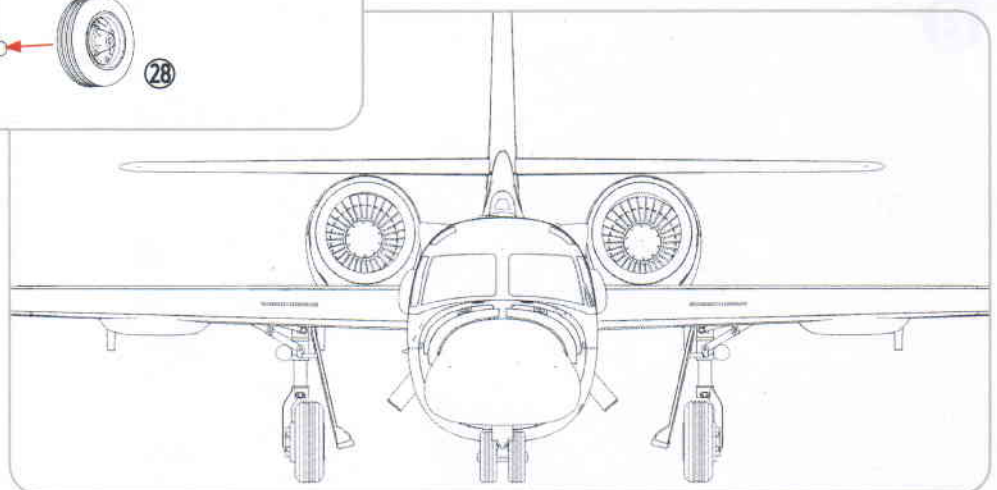
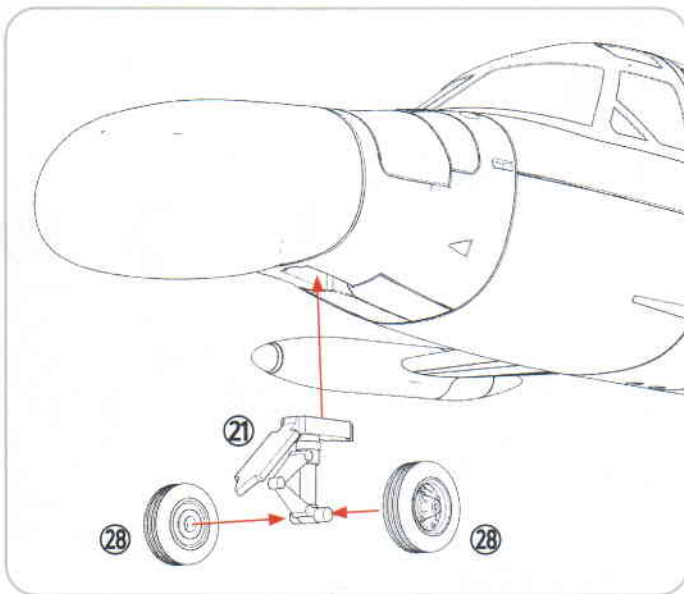
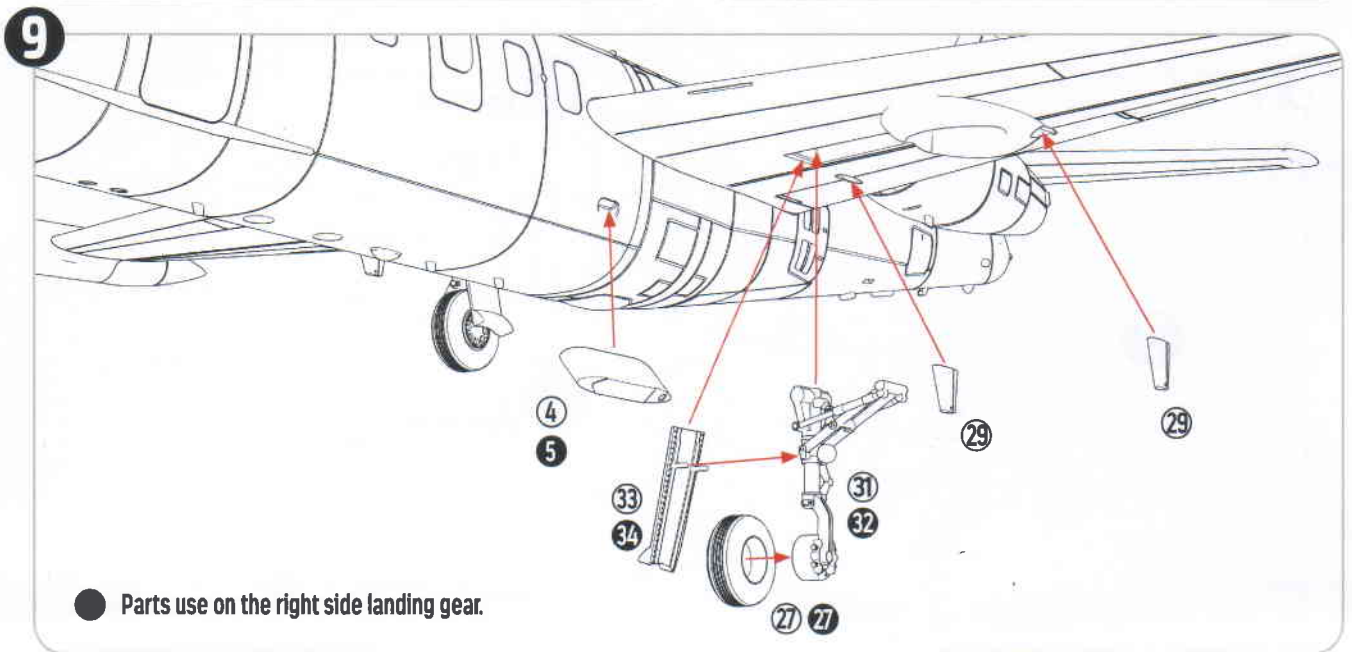
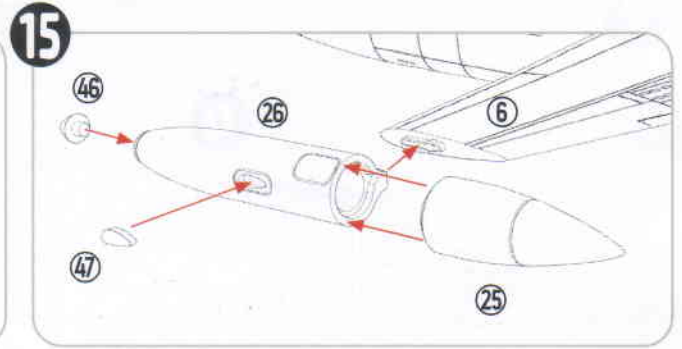
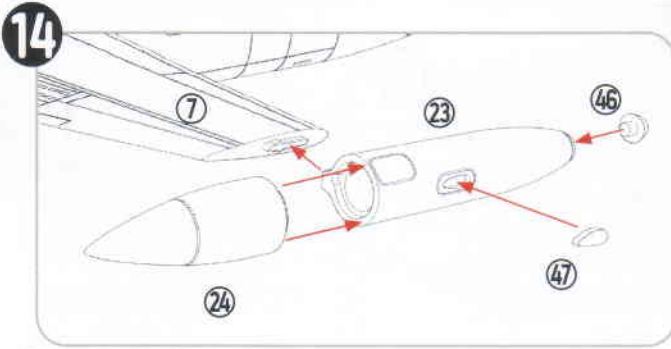

10

Check your references to decide which antennas to use. During the years several of the antennas were replaced.

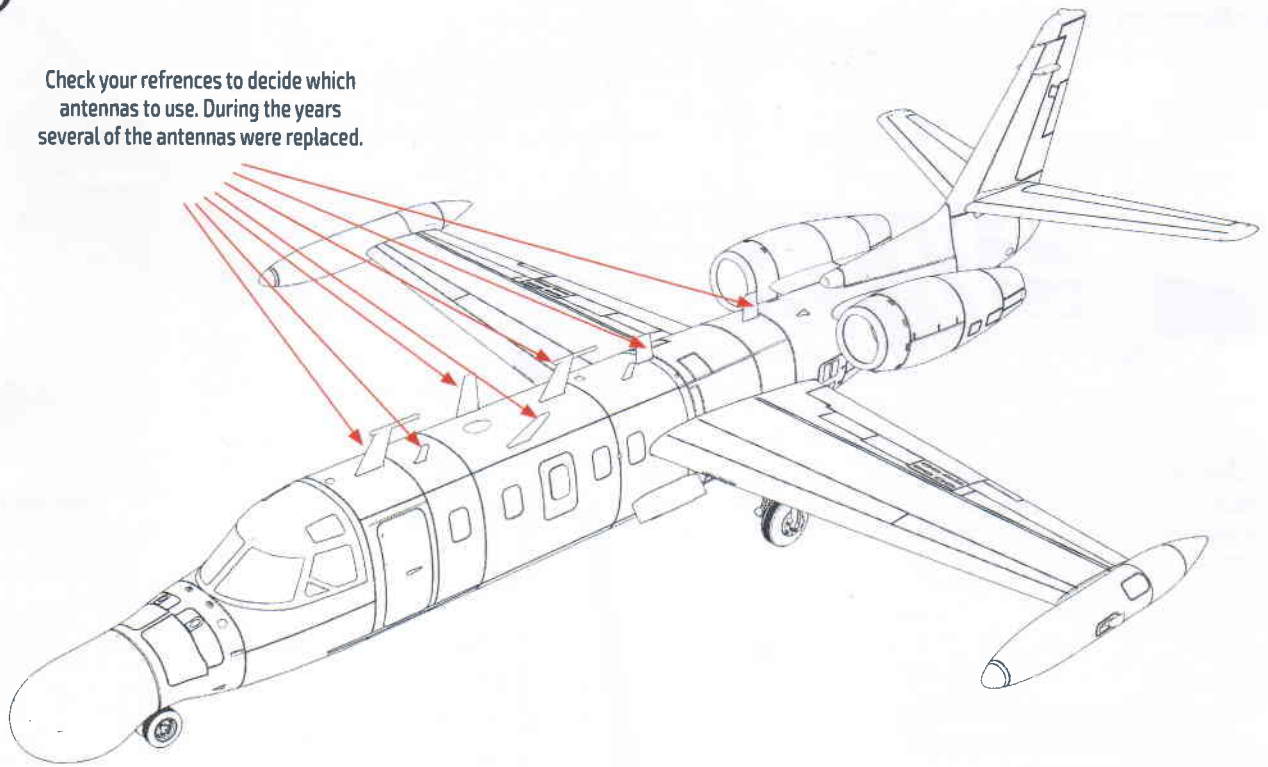

10

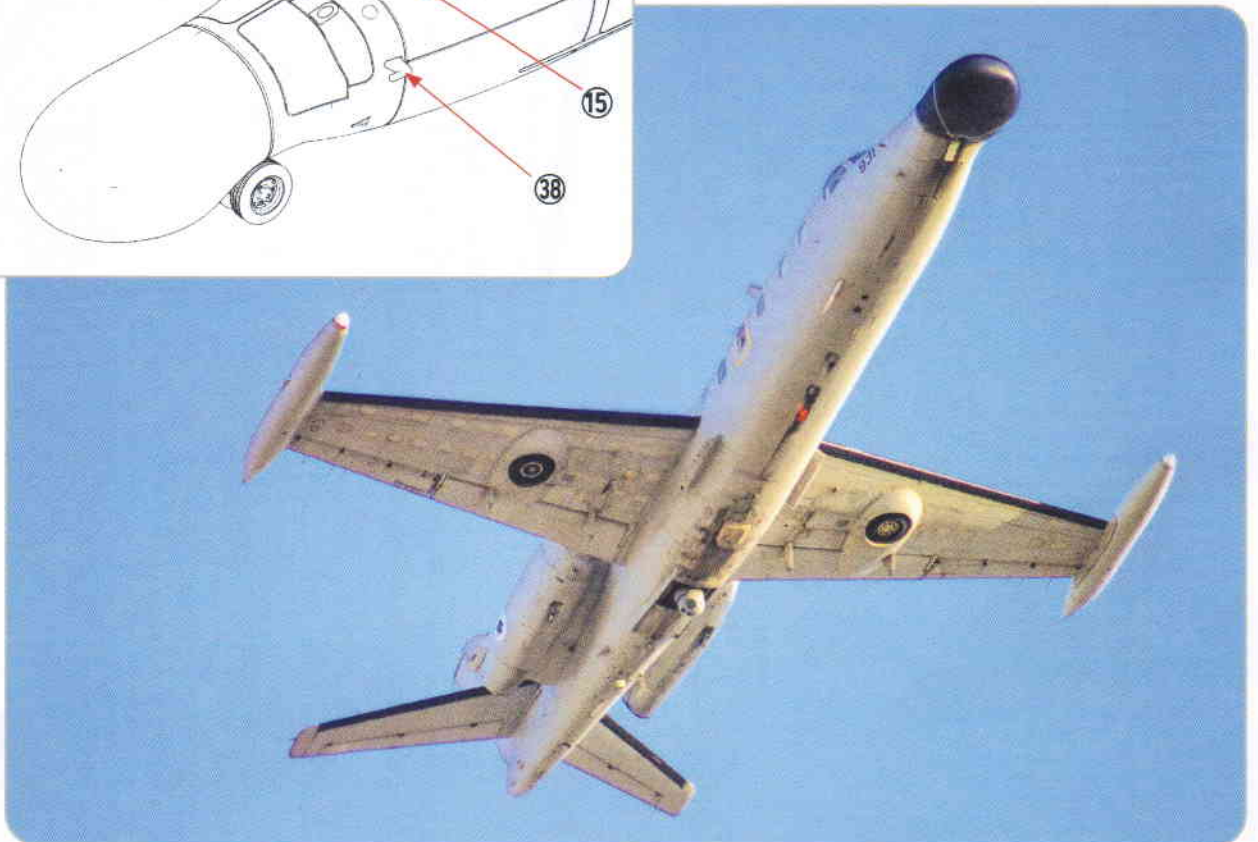
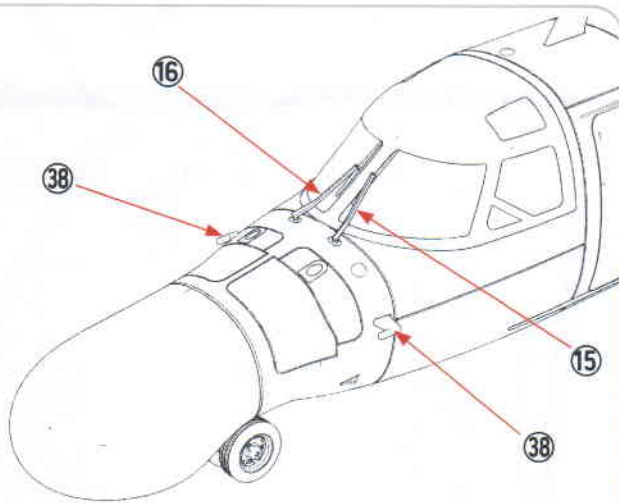

Seascan number 258 as displayed in the Le Bourget Paris show in 1979.

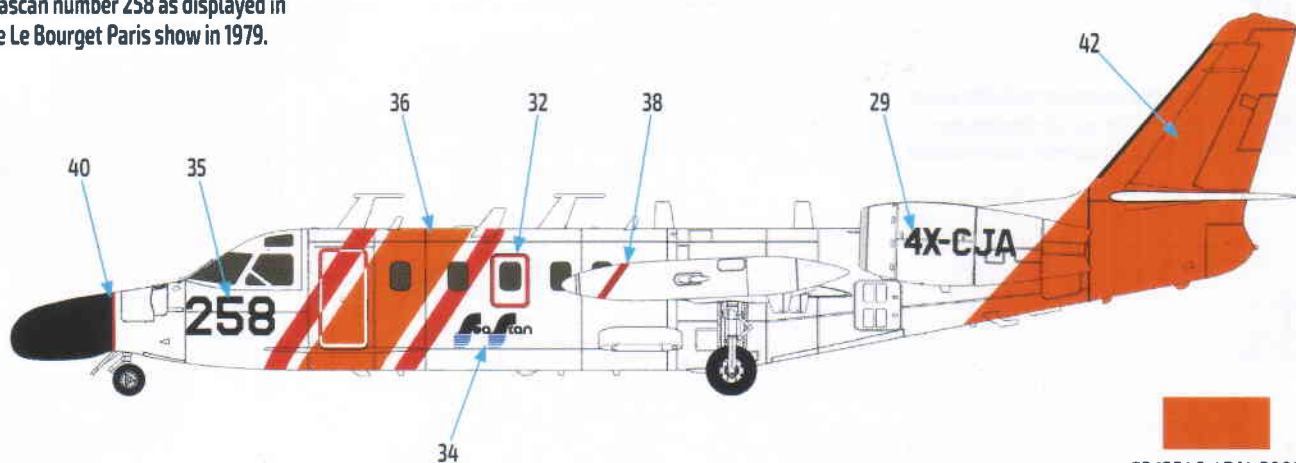

Decals 36 and 37 are optional. You can paint it yourself, matching the same orange color used on the aircraft fin and engines.

The lined drawings are generic. Check your references to decide which antennas and other installations to put on.

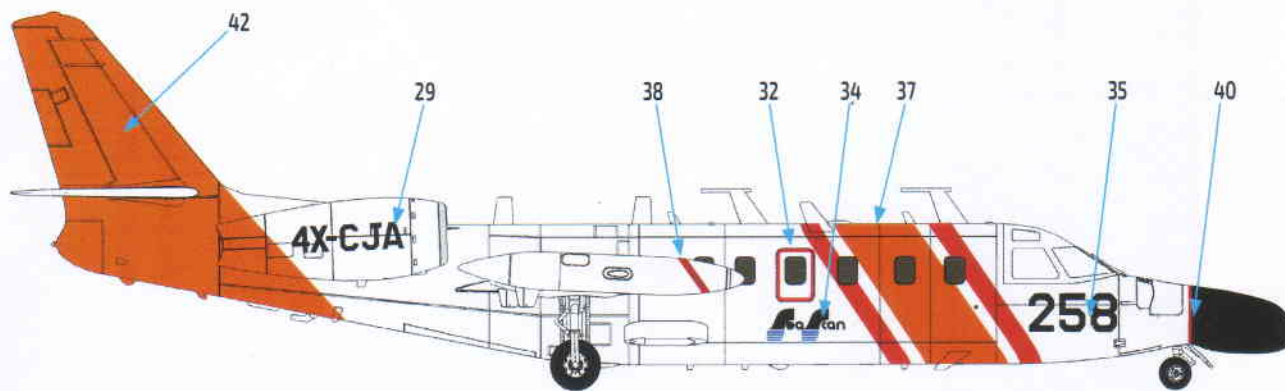
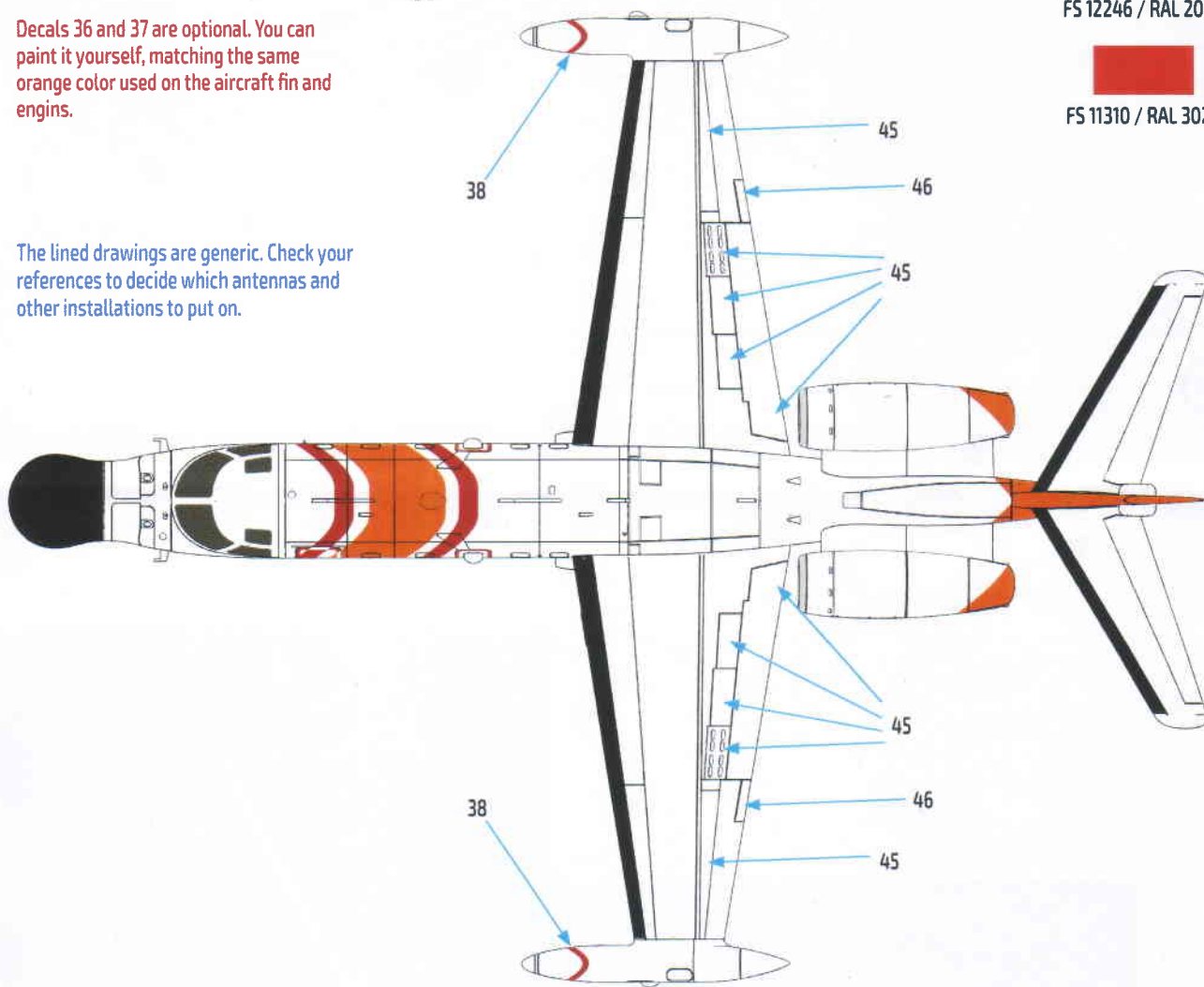



Seascan number 029 in early 1980's as arrived the Israeli Air Force.

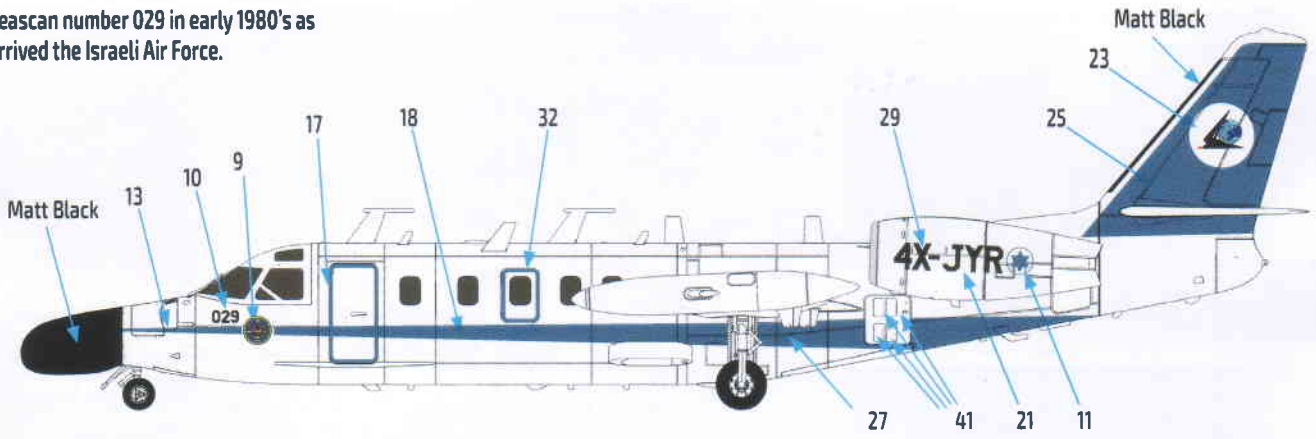

The lined drawings are generic. Check your references to decide which antennas and other installations to put on.

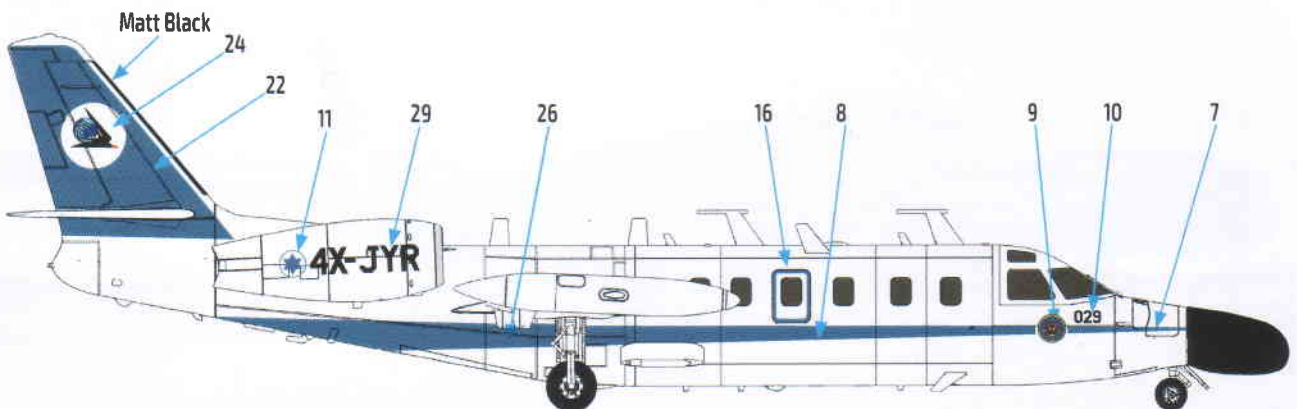
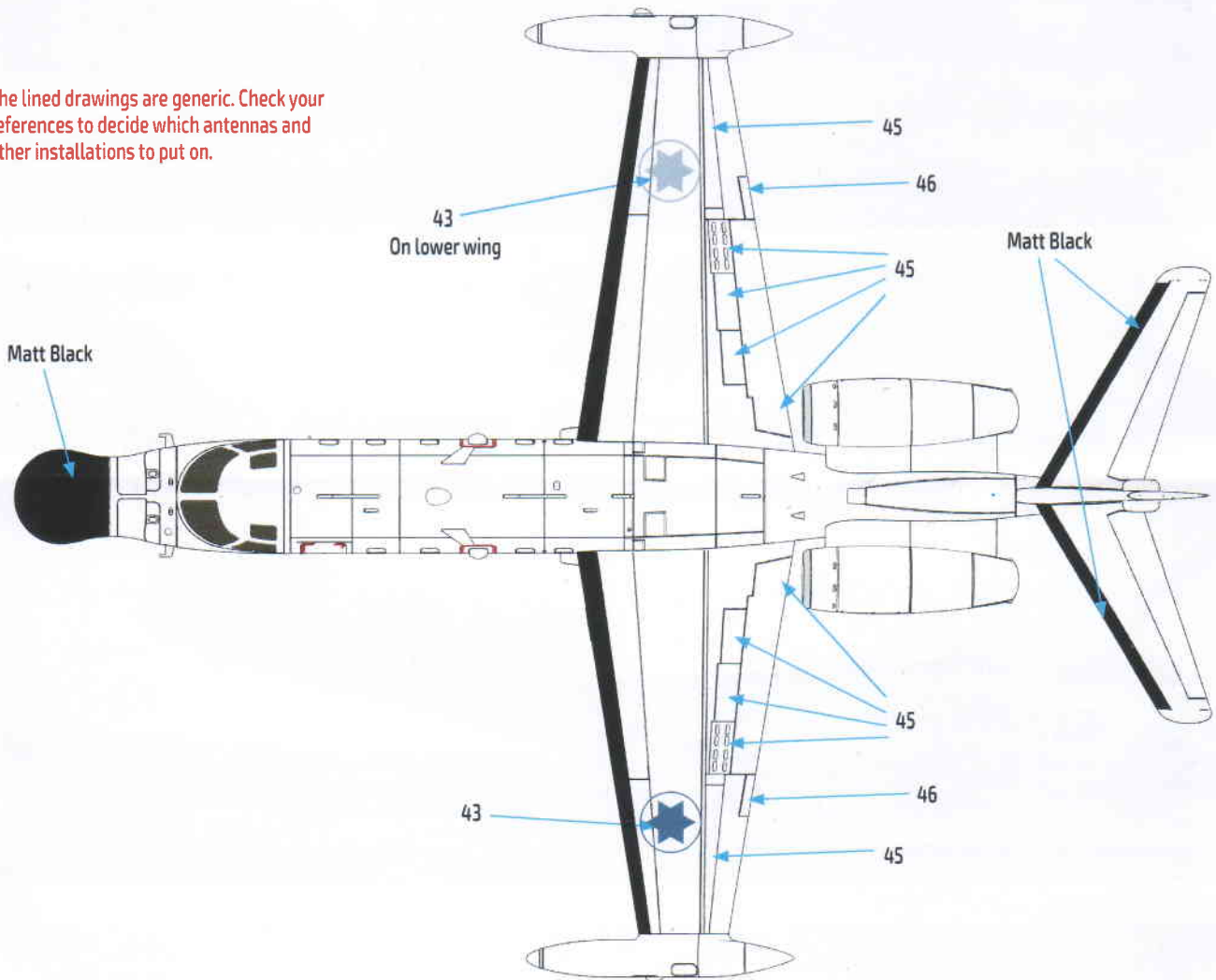





The Australian Border Force operated three IAI Seascan aircraft for border patrols during the 1990s.

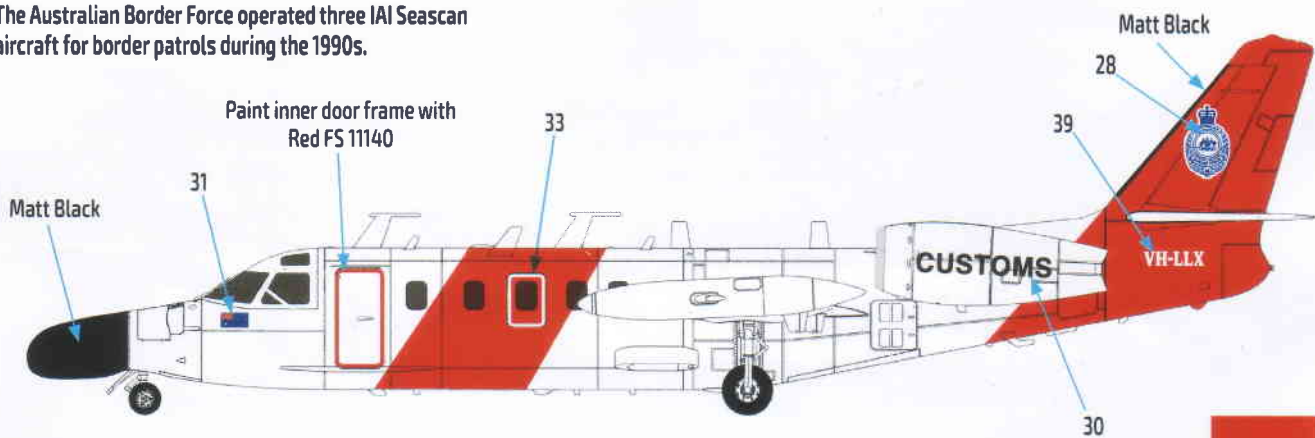

FS 11140/  
BS381 - 538/  
RAL 3001

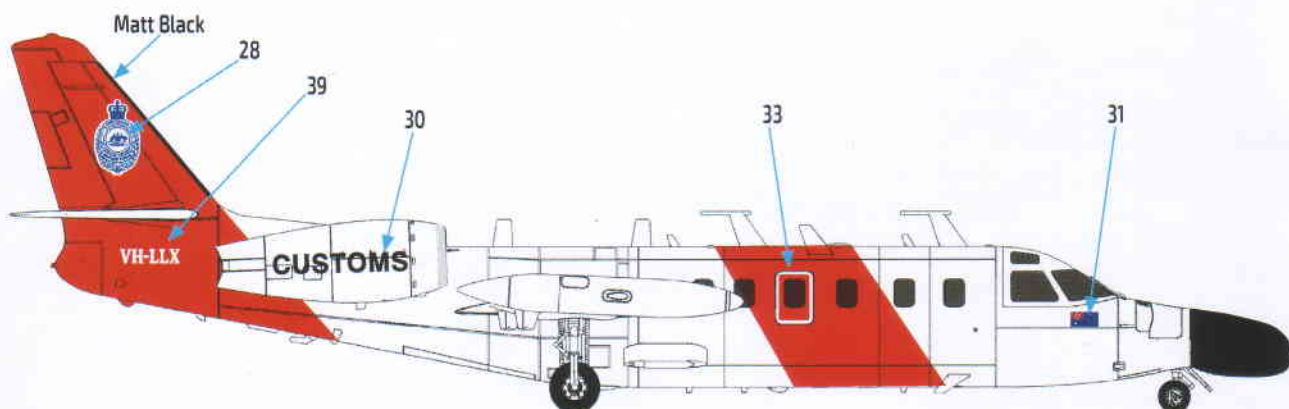
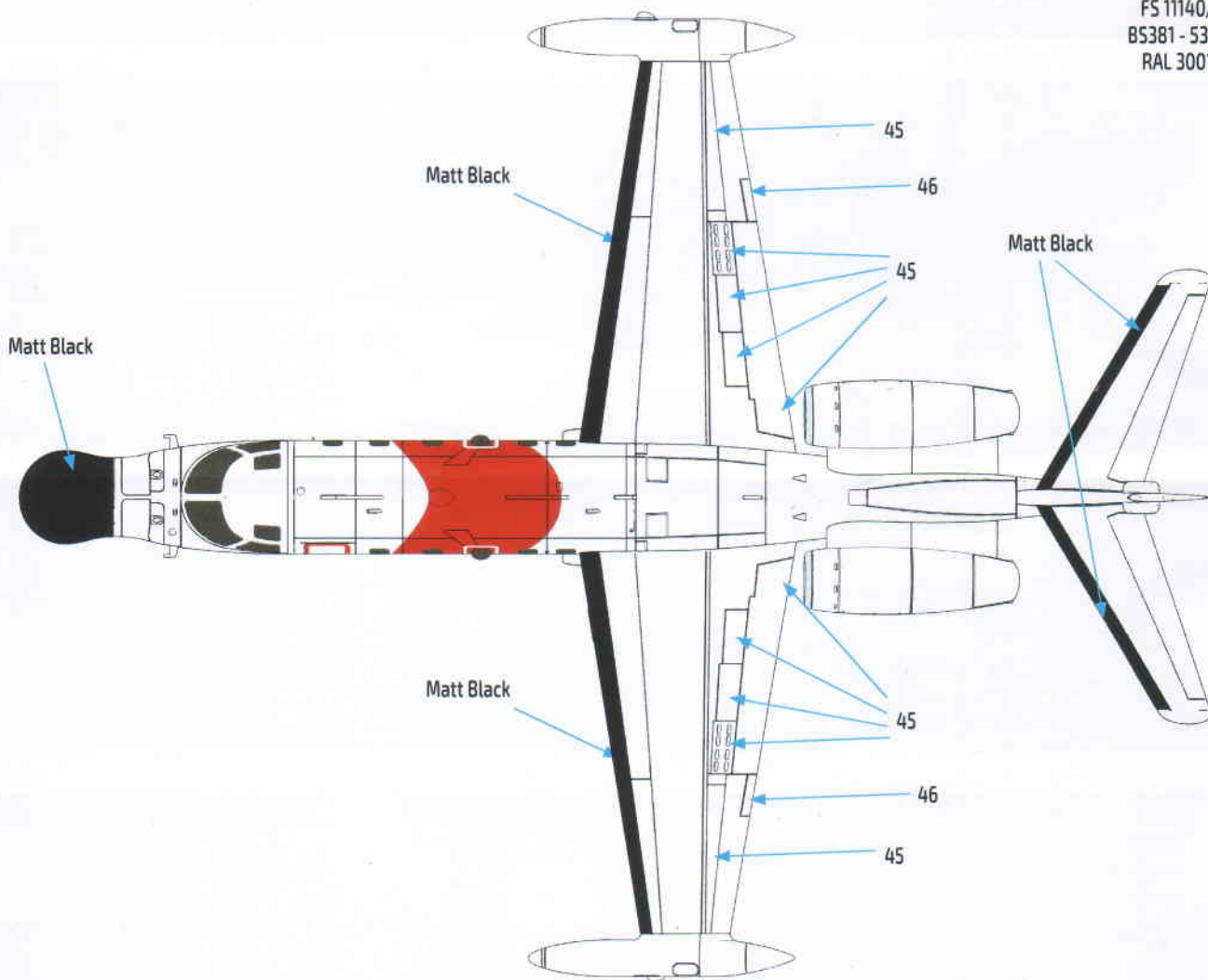

Israeli Air Force Seascan 'Shahaf'

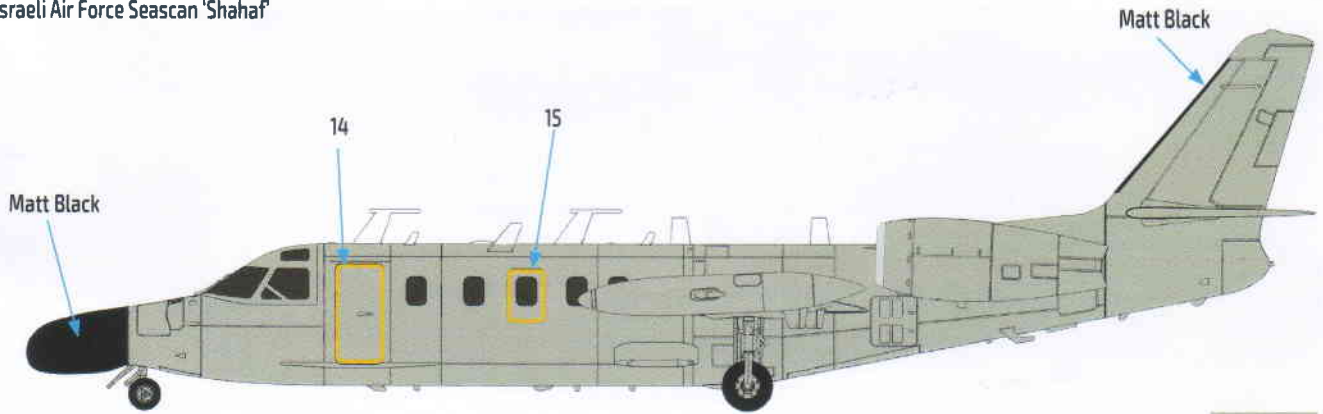

Several IAI Seascans were in service with the IAF for maritime missions.

The aircraft served under 120 Squadron from Lod AFB until August 2008, when the base closed and all heavy transport aircraft, including the Seascans, moved to Nevatim AFB in the eastern Negev desert.

The aircraft was painted overall in Grey FS 36280, similar to the early scheme of the Beechcraft RC-12.

In the last years of its service within the IAF, the aircraft were painted in Grey FS 36375.

Note: This is a general, generic color scheme. Check the attached photos to see the exact markings and the type of antennas used at the time the photo was taken.

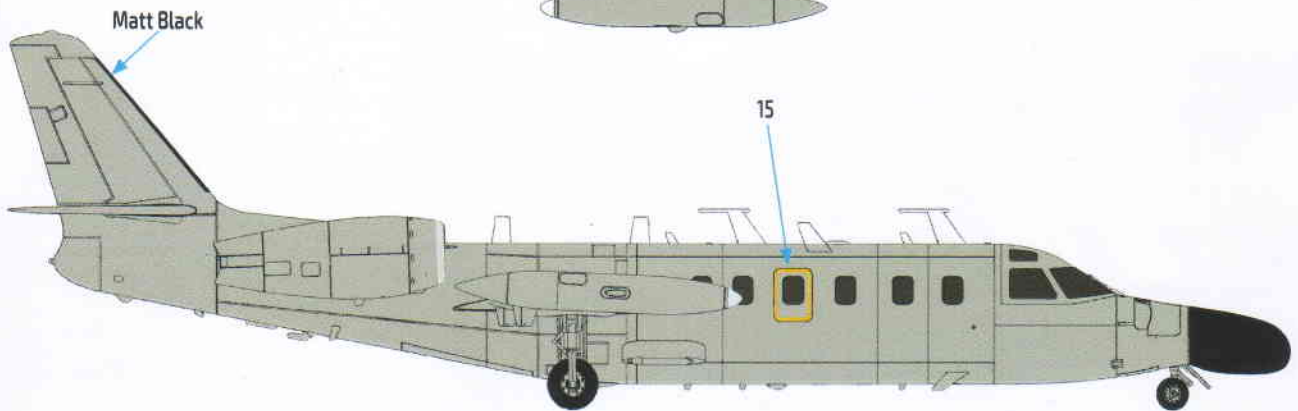
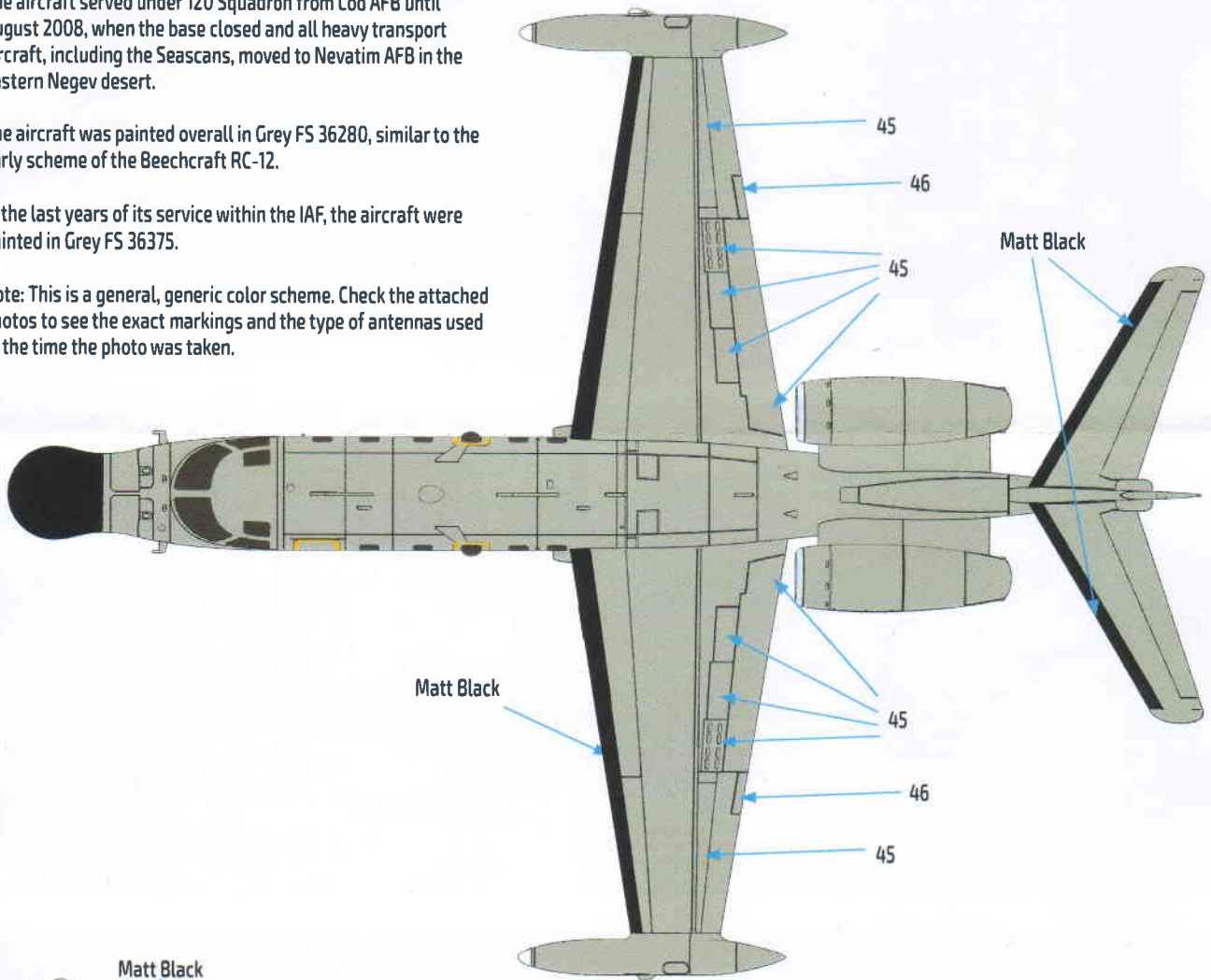

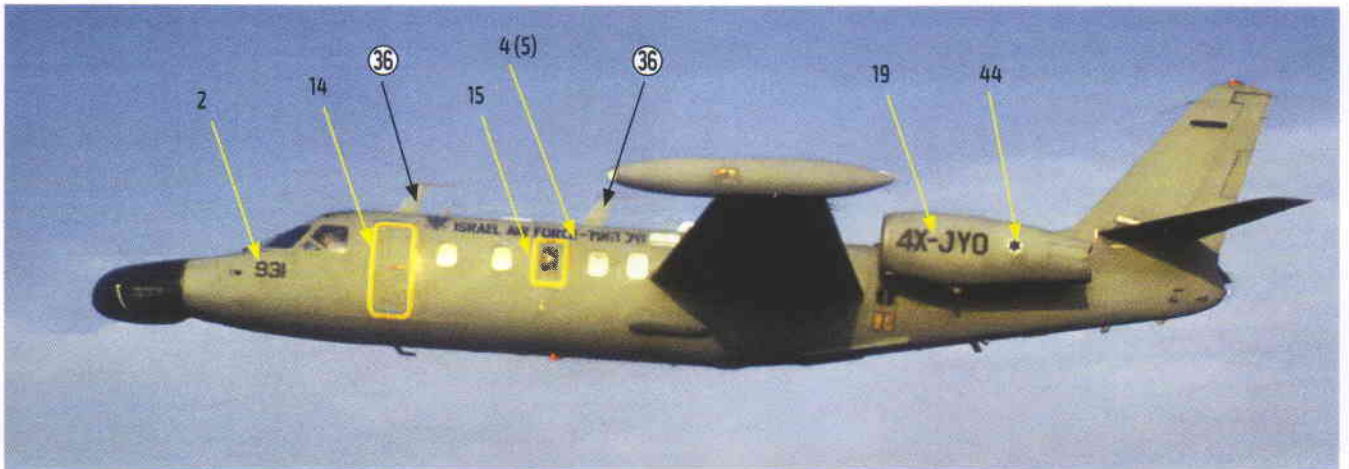
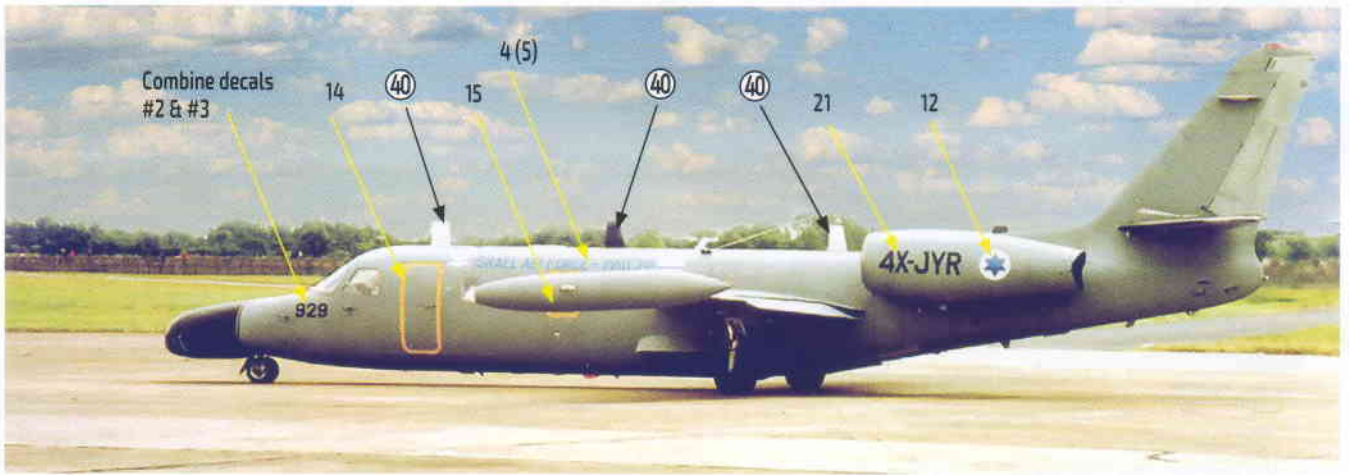

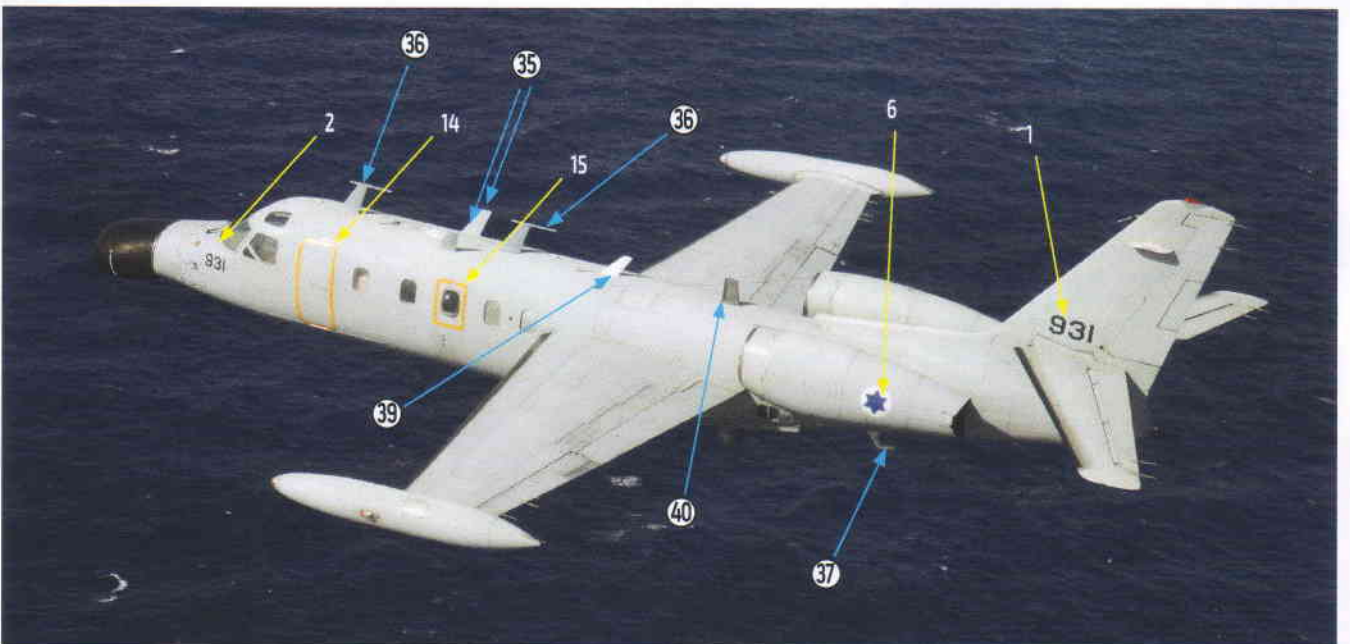
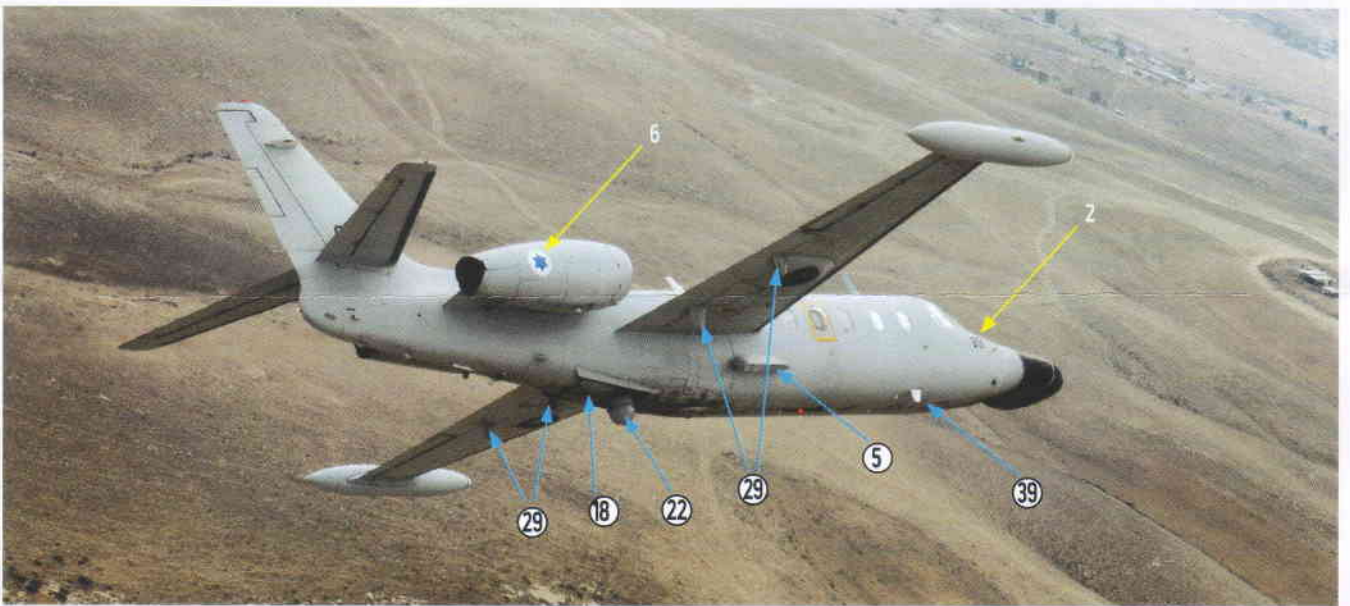
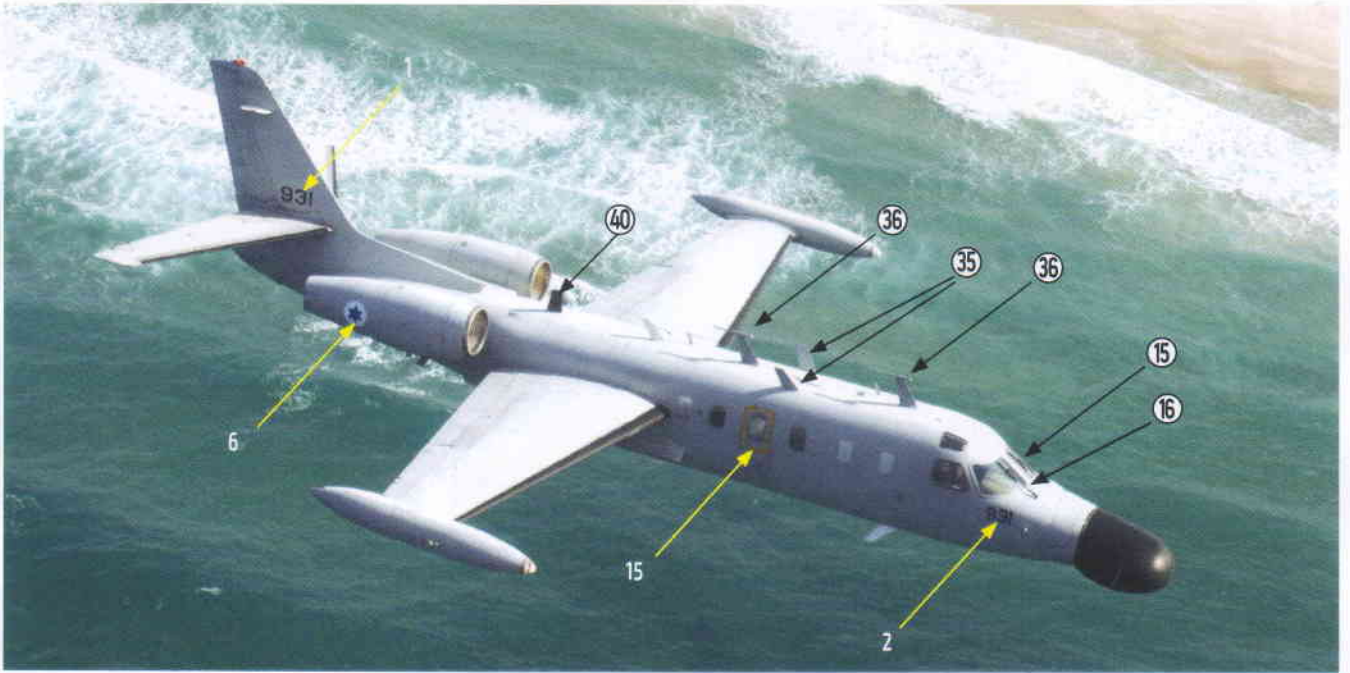



IsraDecal Studio, P.O.Box 764, Kefar-Tavor 1524100, Israel

[www.isradecal.com](http://www.isradecal.com) • [isradecal@gmail.com](mailto:isradecal@gmail.com)

**IsraDecal**   
**STUDIO**