



WWII GERMAN Zündapp KS750

ITEM.L3507

Zundapp--"Zunder- und Apparatebau G.m.b.H."--- was originally founded in 1917 in Nuremberg by Fritz Neumeyer, as a producer of detonators. In 1921, the company diversified into the construction of motorcycles and since then, Zundapp has become a famous German motorcycle brand. Zundapp's history of heavy motorcycles began in 1933 with the K-series. They introduced the closed engine case, a novelty at the time. (The "K" stands for "Kardantrieb", i.e. enclosed driveshaft with two universal joints, a type of drivetrain, which these models featured.)

In WWII, the military forces of Deutschland equipped a large quantity of military motorcycles. Before the Blitzkrieg began in Sep, 1939, lots of motorcycles and motorcycles with sidecar, more than armies of any other countries, were used in Wehrmacht and Das Heer founded the units using motorcycles in 1935. In Nov, 1937, according to the requirement of OKW (the Supreme Command of the Armed Forces), Zundapp developed the specialized model of heavy motorcycle with sidecar and then the KS750 series was completed. When the KS750 series was under designing, thinking of the inclement surrounding of battleground and inconvenient maintaining conditions, bumper plate was installed at the bottom of the engine as protection. The output torque of KS750 is so large that the motorcycle can haul heavy load. That was the nickname of "green elephant" came from in the army. KS750 used propeller shaft gearing system. For cross-country using, the wheel of sidecar also can output the power of the engine and have reverse gear. Meanwhile, the motorcycle has differential with lock system and the rear wheel / side wheel have powerful hydraulic brake which can trig the 460kgs heavy body effectively. KS750 also use the would-famous Zundapp parallelogram front fork tubes and have excellent control function. Comparing with other motorcycles, KS750 series have lighter weight and faster speed and can suit the rude landform. They were used as scout vehicles in the war. From 1940 on, Zundapp produced more than 18'000 units of the KS750 for the German Wehrmacht, and KS750 became one of the most extensive using motorcycle in the WWII.

尊达普公司由弗里茨·纽梅尔于1917年建立，主要从事雷管等爆破装置的制造。1921年开始转入摩托车制造行业，并逐渐成为德国的一个著名摩托车品牌。尊达普重型摩托车的历史开始于1933年。那一年，尊达普推出了K系列摩托车，该系列采用了封闭式的发动机室，K代表kardantrieb，表示封闭式带万向节驱动轴，这也是尊达普K系列摩托车的重要特征。

二战期间，德国大量装备军用摩托车，早在闪电战开始之前，就已经采用了比其他任何国家军队都多的摩托单车和挎斗摩托车，1935年德国陆军就成立了军用摩托车部队。1937年11月，尊达普接受德国陆军最高统帅部的要求，为军队研制专用挎斗摩托，尊达普公司推出了KS750。KS750重型摩托在设计上考虑到了严酷战争环境以及对保养的不便，在摩托的发动机底部加装了防撞板以保护引擎。它的输出扭矩大得惊人，能够拖拽相当大的载荷，在军队中素有“绿色大象”之称。KS750采用轴传动方式，为了越野需要，其挎斗车轮带有动力，并且配备了倒档。它还带有可锁定的差速器，后轮和挎斗车轮安装了强有力的液压刹车，能有效地制动它160公斤的庞大身躯。KS750还采用了世界闻名的Zundapp平行四边形前叉，操纵性非常出众。

KS750重型摩托车和其他摩托车相比，此摩托车重量轻，速度快，能适应崎岖的地形，主要被用来执行侦察任务。从1940年起，尊达普累计生产了超过18000辆KS750型摩托车，是战争中德军使用最广泛的摩托车之一。

注意:

1. 勿于近火處使用膠水或油漆，並打開窗戶保持空氣流通。
2. 塗料的號碼請參考本欄以下的說明。本品本身不包括膠水和塗料。
3. 自膠架中取出部件時，應用模型專用剪，並用界刀或小鏗除去多余膠料。
4. 各圖形的含義可參考本欄以下的說明。

CAUTION:

1. When you use glue or paint, do not use near a open flame, and use in a well-ventilated room.
2. See below for the color list. Glue and paint are not included in this kit.
3. When you take parts off the runner frame, use the modeling scissors and trim excess plastic with a cutter or a file.
4. See below for the meaning of symbols.

組み立ての注意

- 接着剤や塗料は火の近くで使わないでください。使用の際は換気を良くして下さい。塗料指定のは下記のとおりです。接着剤や塗料は入っていないので別に求めて下さい。部品をランナーから切り離す時は模型用ハサミ等を使い、餘分な部分はカッターやヤスリ等で仕上げして下さい。組立図のサインマークは下の説明をご覧下さい。

把孔填平 Fill hole 穴を埋めてください	水貼紙 Apply Decal 水貼紙を貼ってください	除去 Cut off 切り取ってください	不用膠水黏合 Do not cement 接着しないでください	開孔 Open hole 穴をあけてください	另一面相同制作 Do the same on the opposite side 反対側も取り付けてください	零件晾干時間2-3分钟 Wait 2-3 minutes until the cement dry 接着剤が乾くまで2-3分待ちます
瞬間接著劑 Instant glue for metal 瞬間接著劑(金屬用)	注意 Be careful 注意してください	膠水黏合 Cement Together 接着してください	選擇使用 Optional どちらかを選んでください	磨去 Remove 磨くこと	制作二組 Make two sets 2個作ってください	彎折 Bend 折り曲げてください

H 1 GSI CREOS CORP. HOBBY COLOUR 1 GSI CREOS CORP. MR.COLOUR

H 403	暗黃色	DARK YELLOW
H 18 28	黑鐵色	STEEL
H 37 43	木棕色	WOOD BROWN
H 70 60	德軍灰	RLM02 GRAY
H 77 137	輪胎黑	TIRE BLACK
H 8 8	銀色	SILVER
H 90 47	透明紅	CLEAR RED

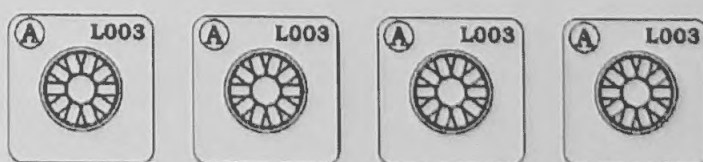
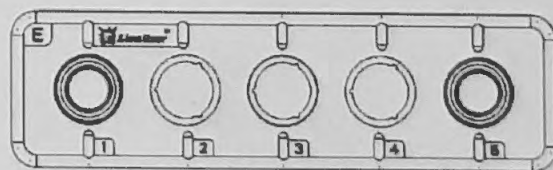
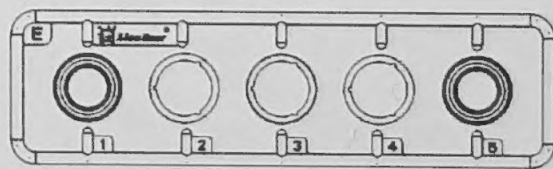
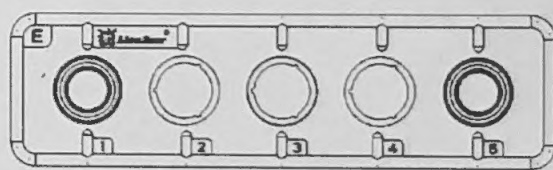
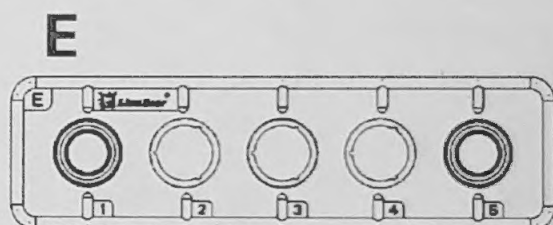
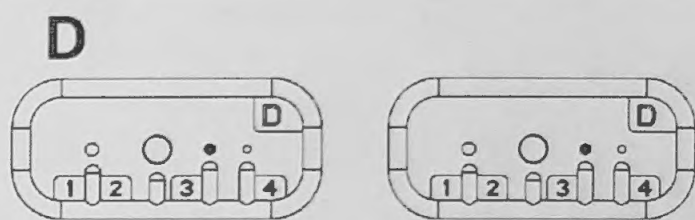
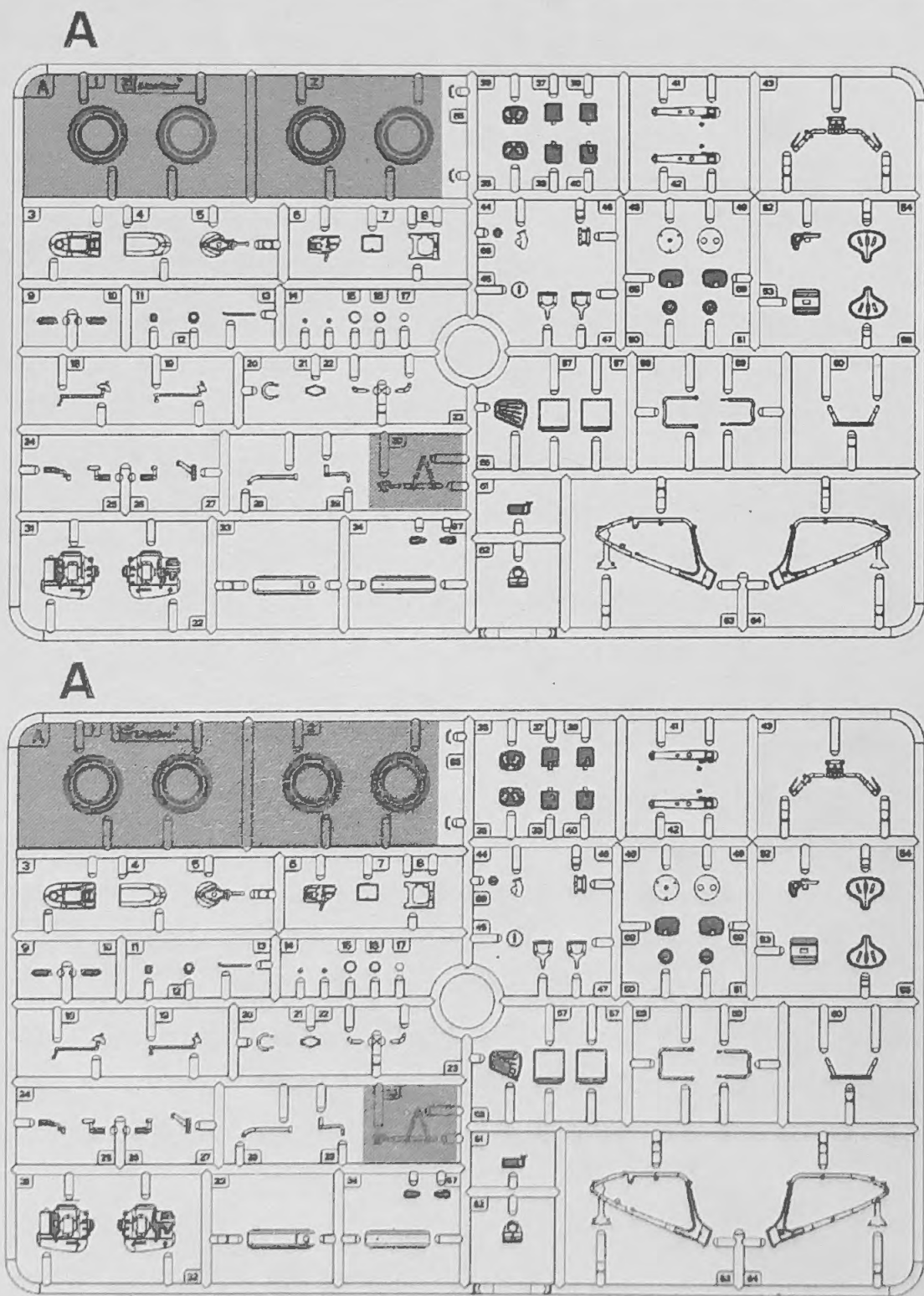

Metal Spokes A
金屬輻條A

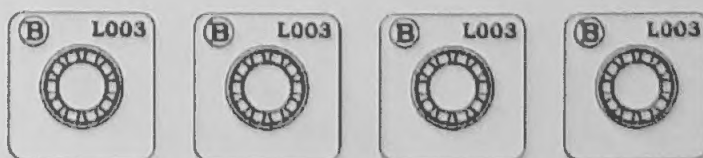

Metal Spokes B
金屬輻條B

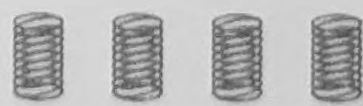

Metal spring
金屬彈簧

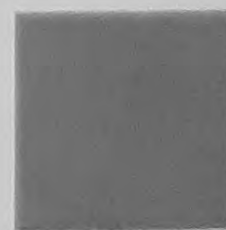

Parts not for use.
不使用的部件

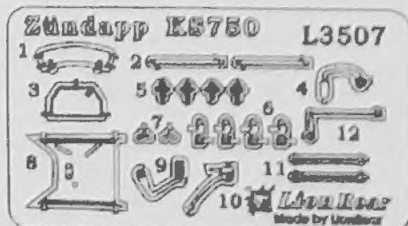
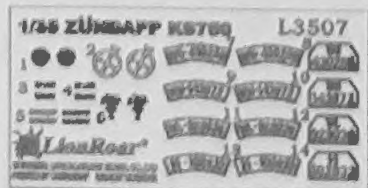
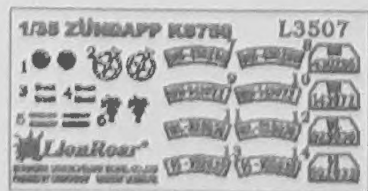
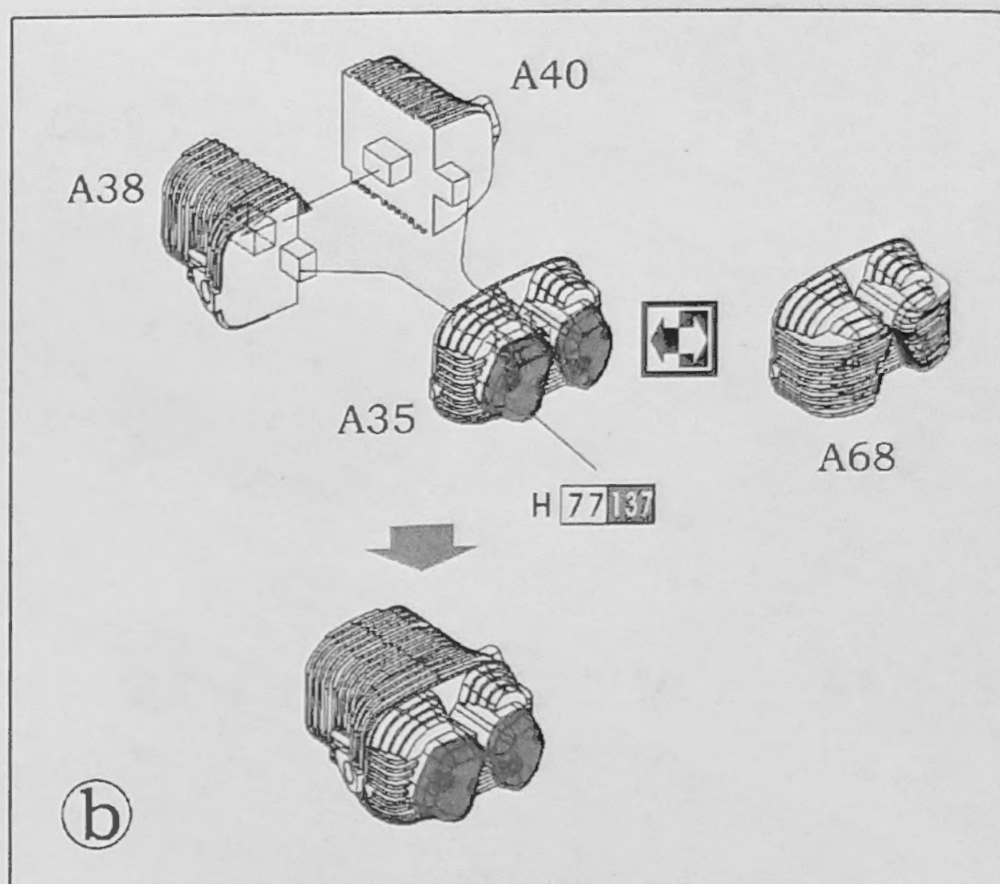
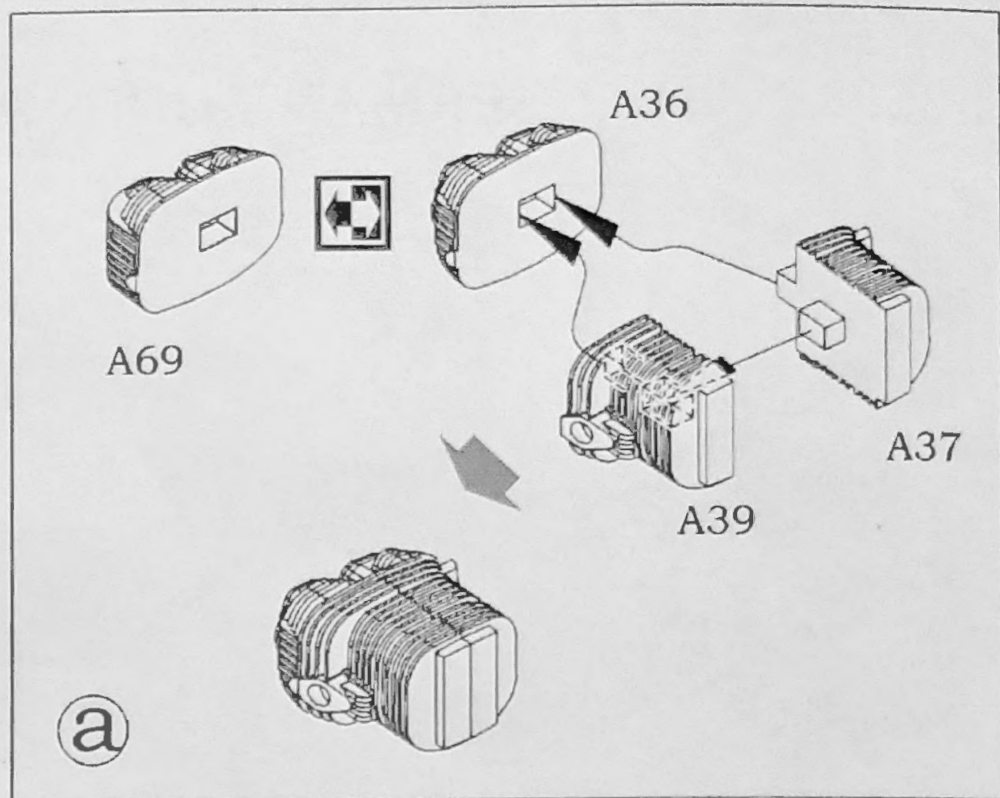
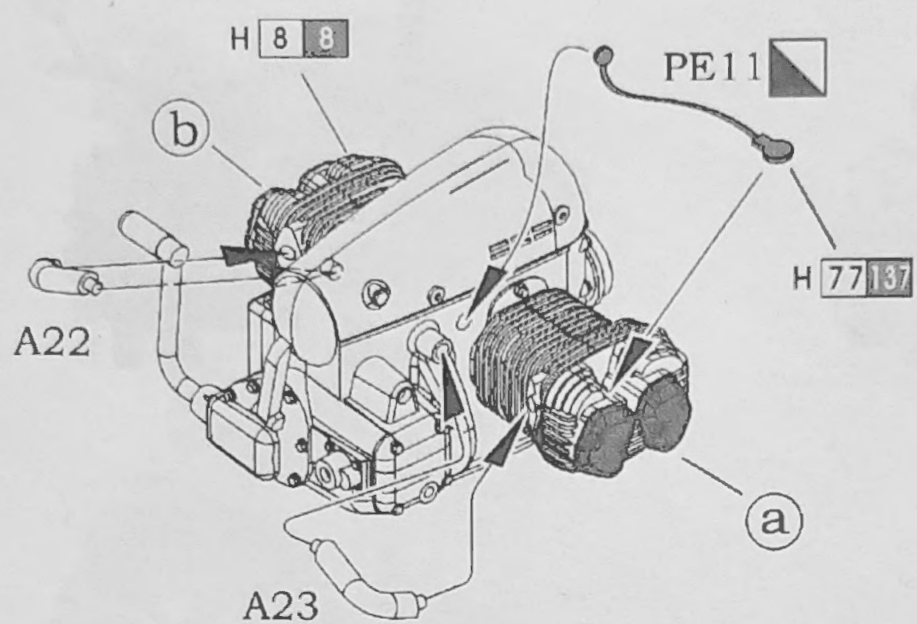
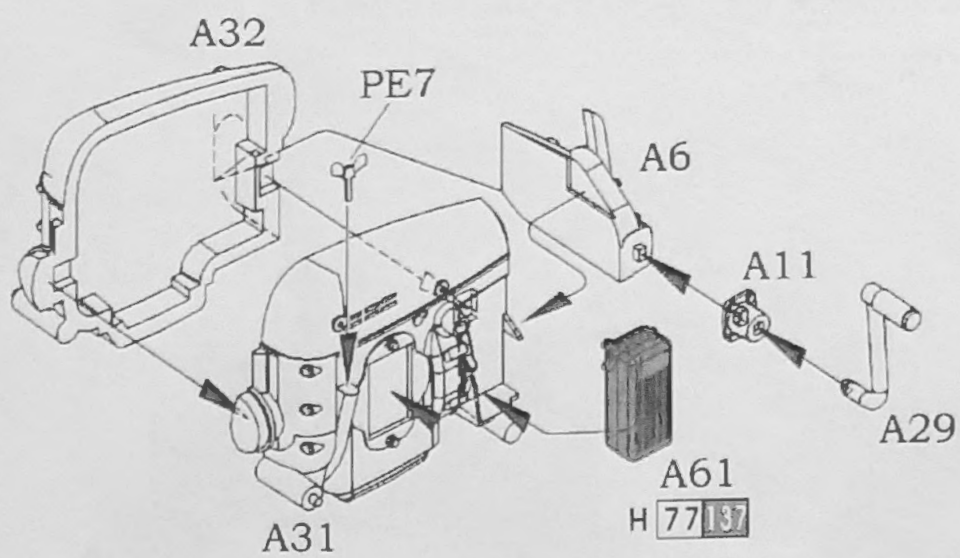

Photo etched parts
蝕刻片



Decal
水貼紙

1



2

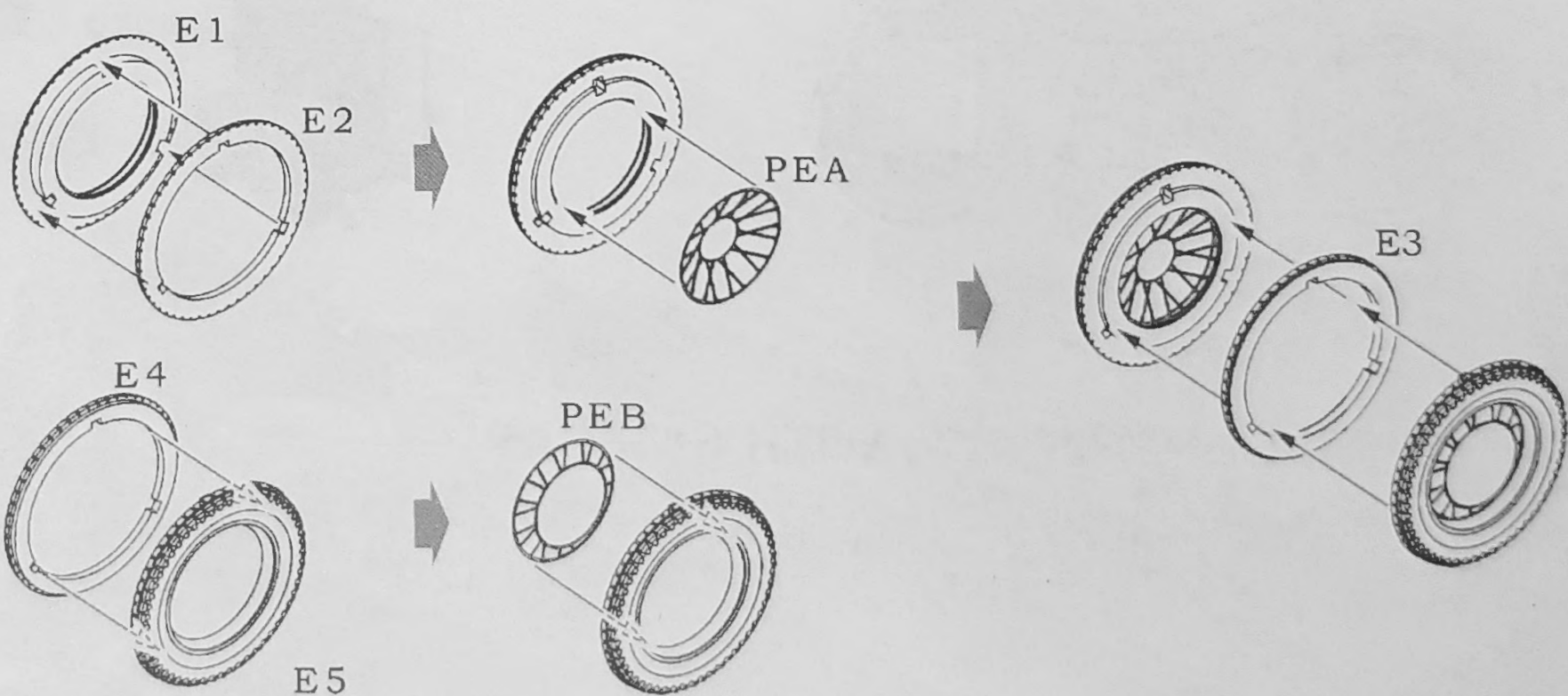

3

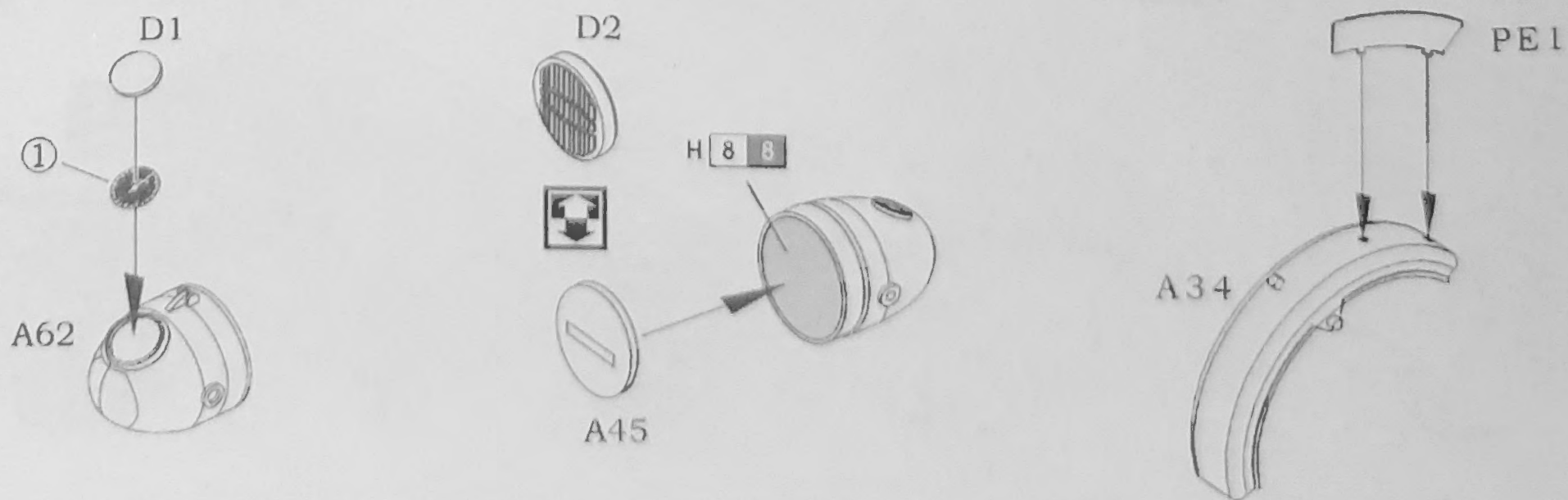

4

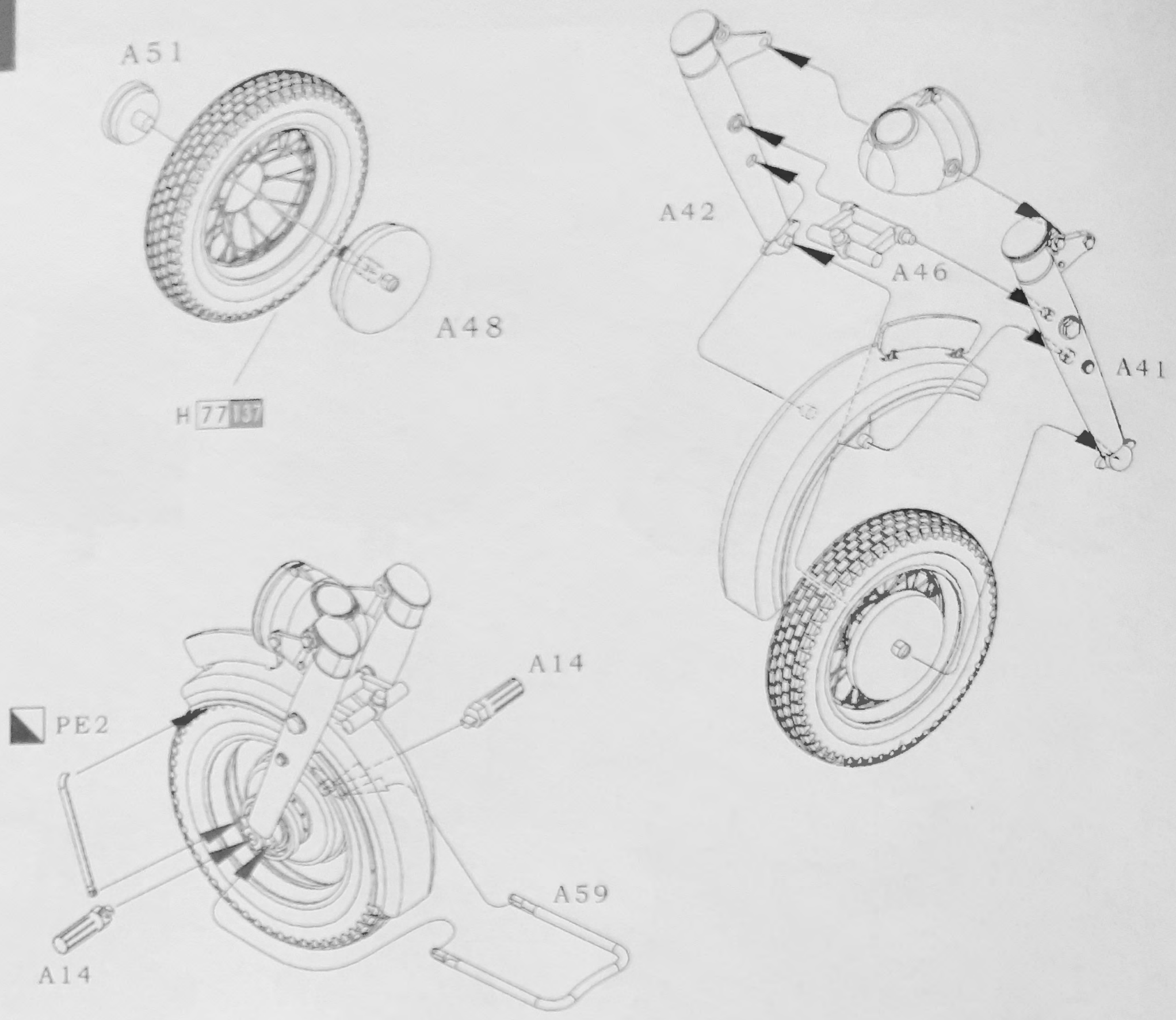

5

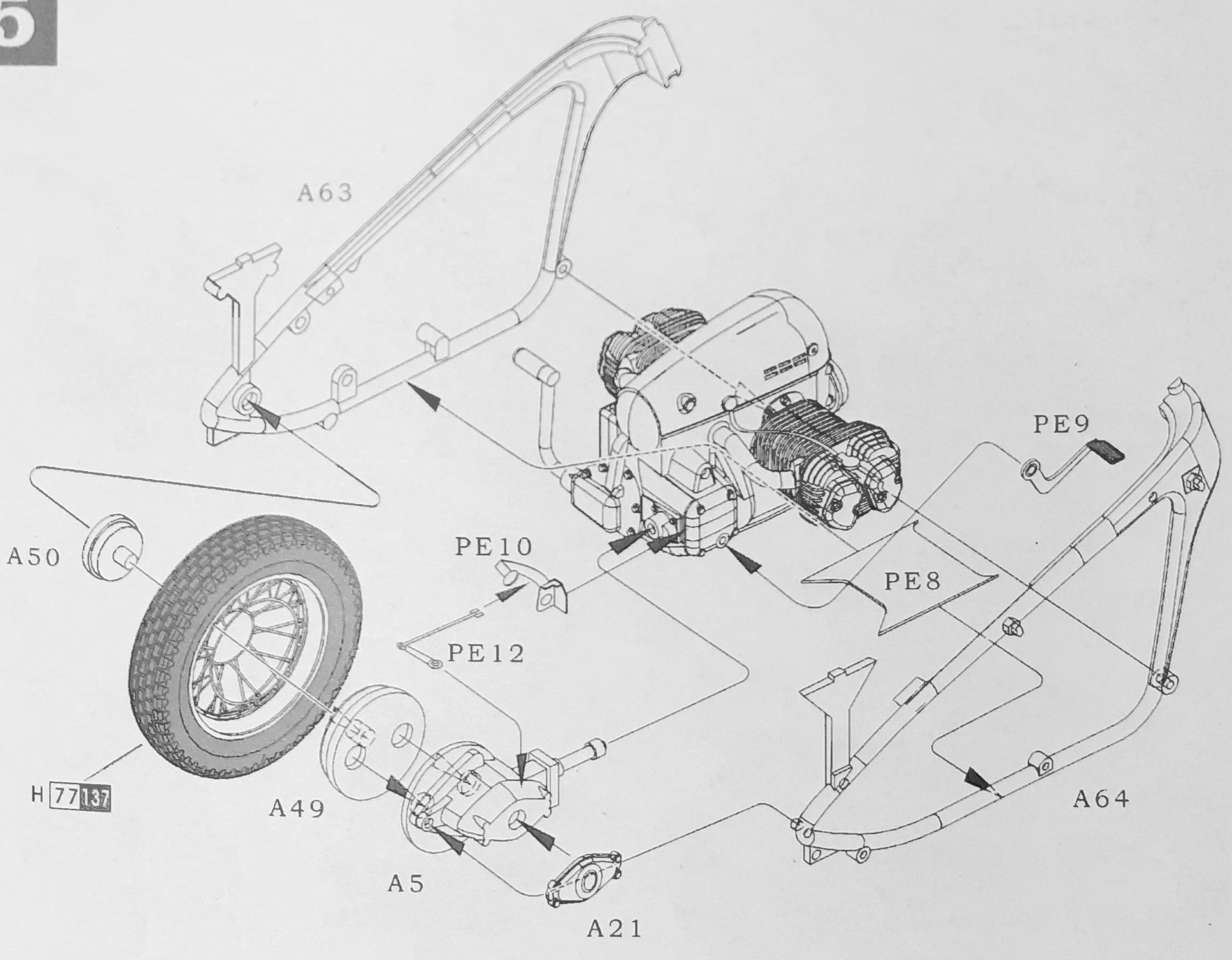

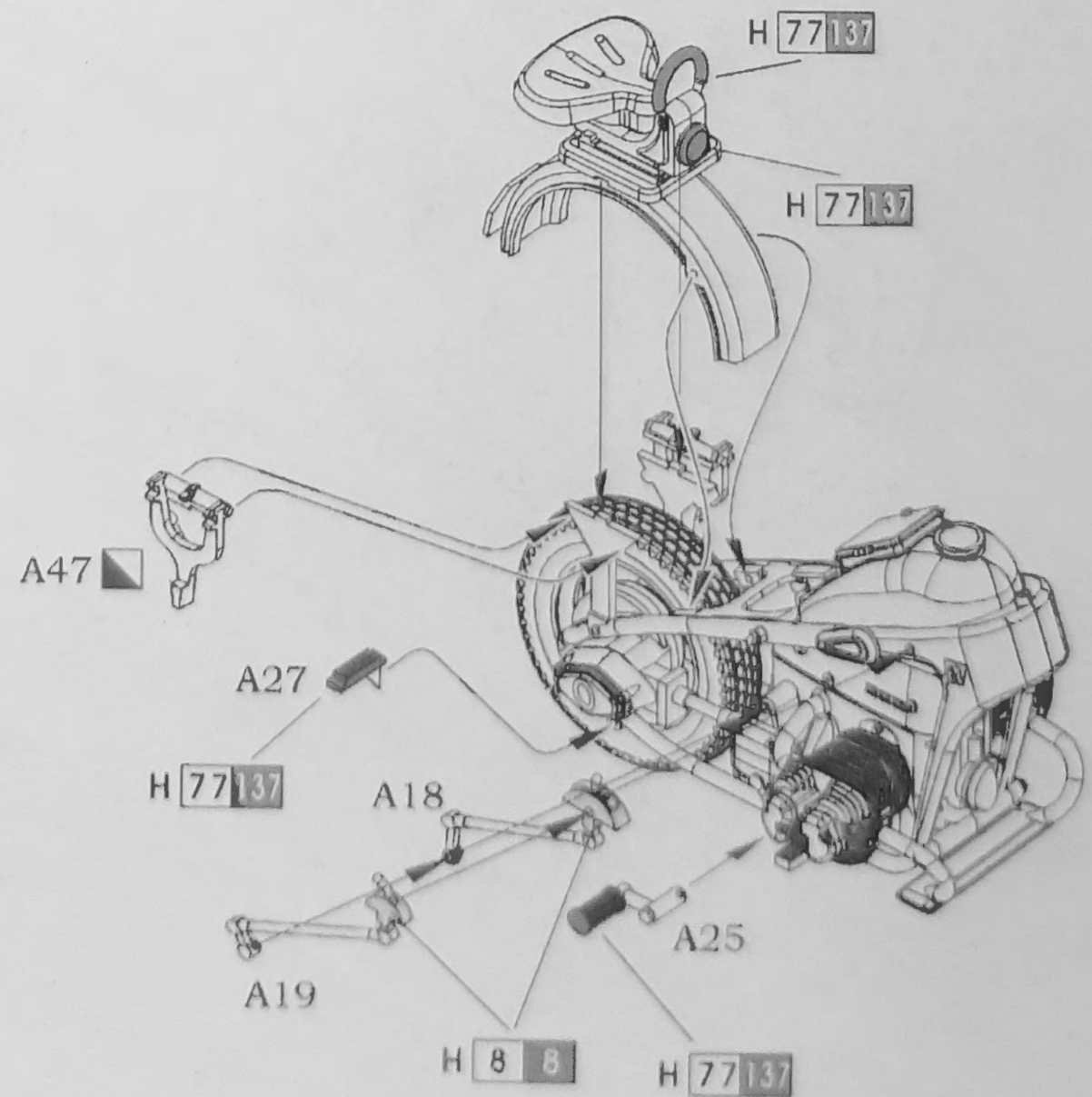
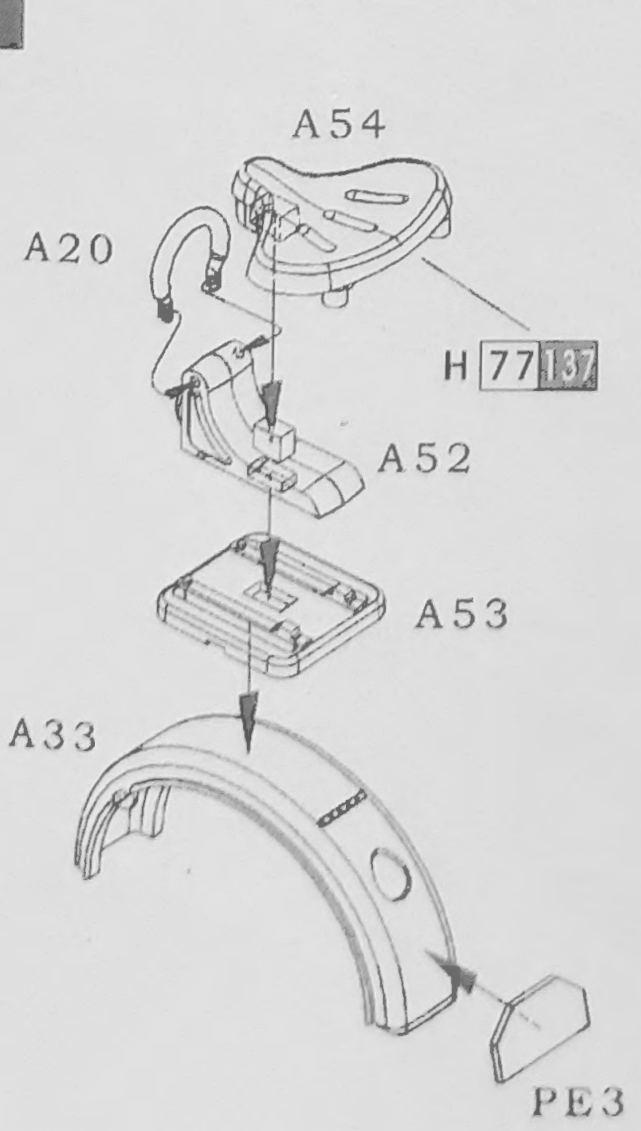
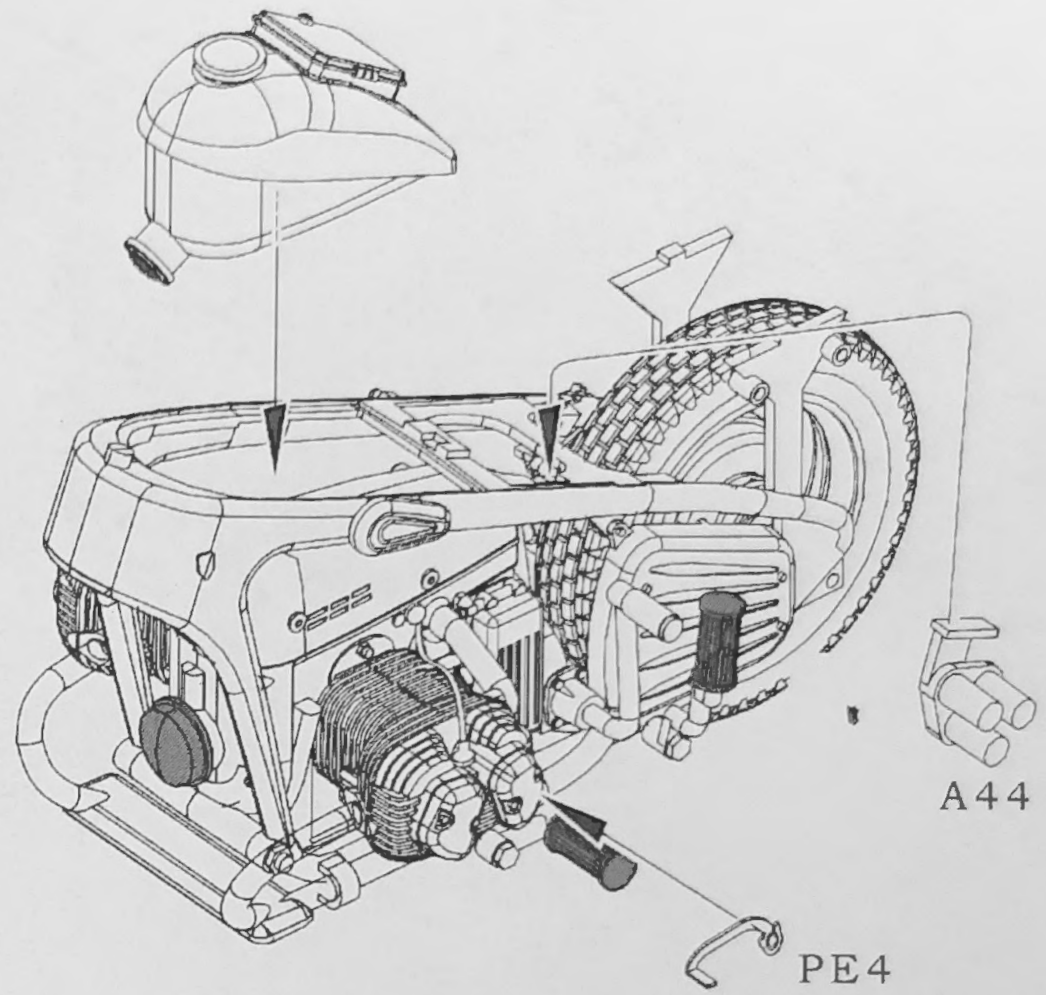
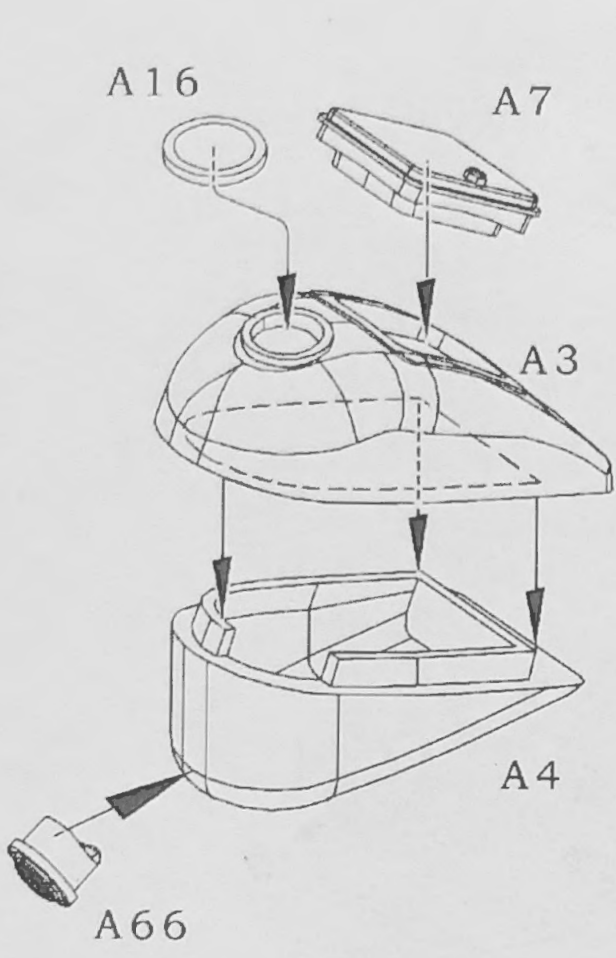
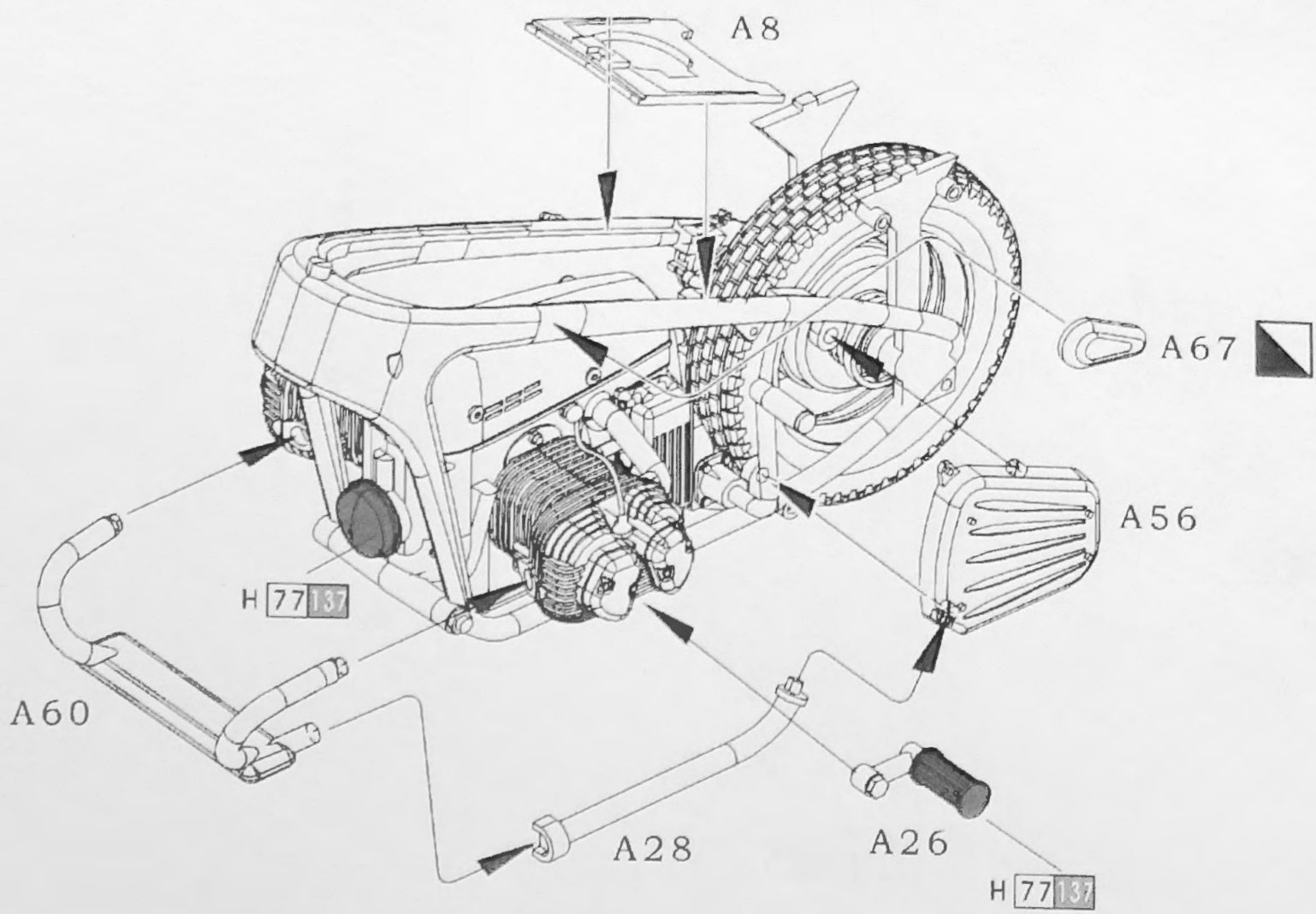

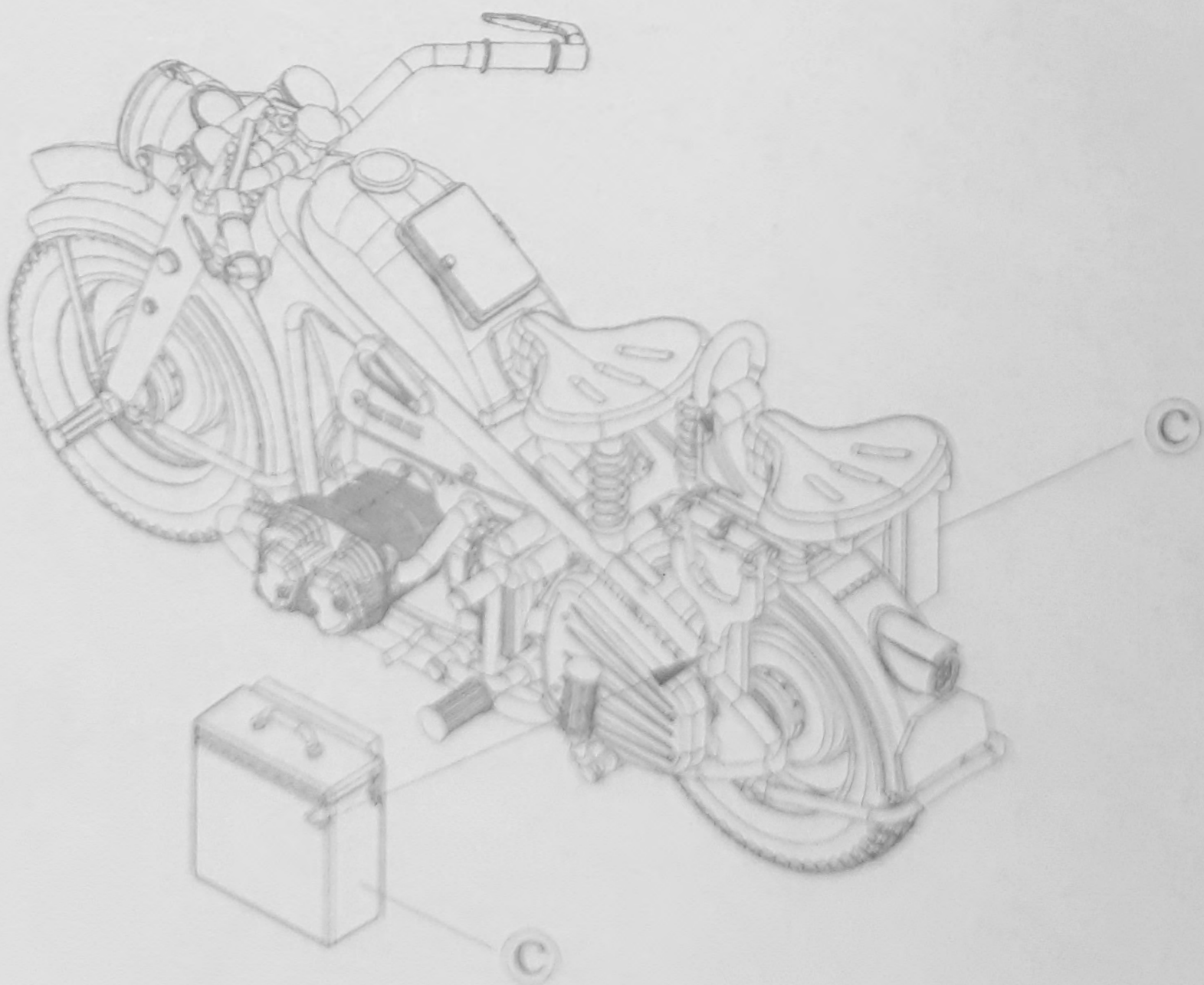
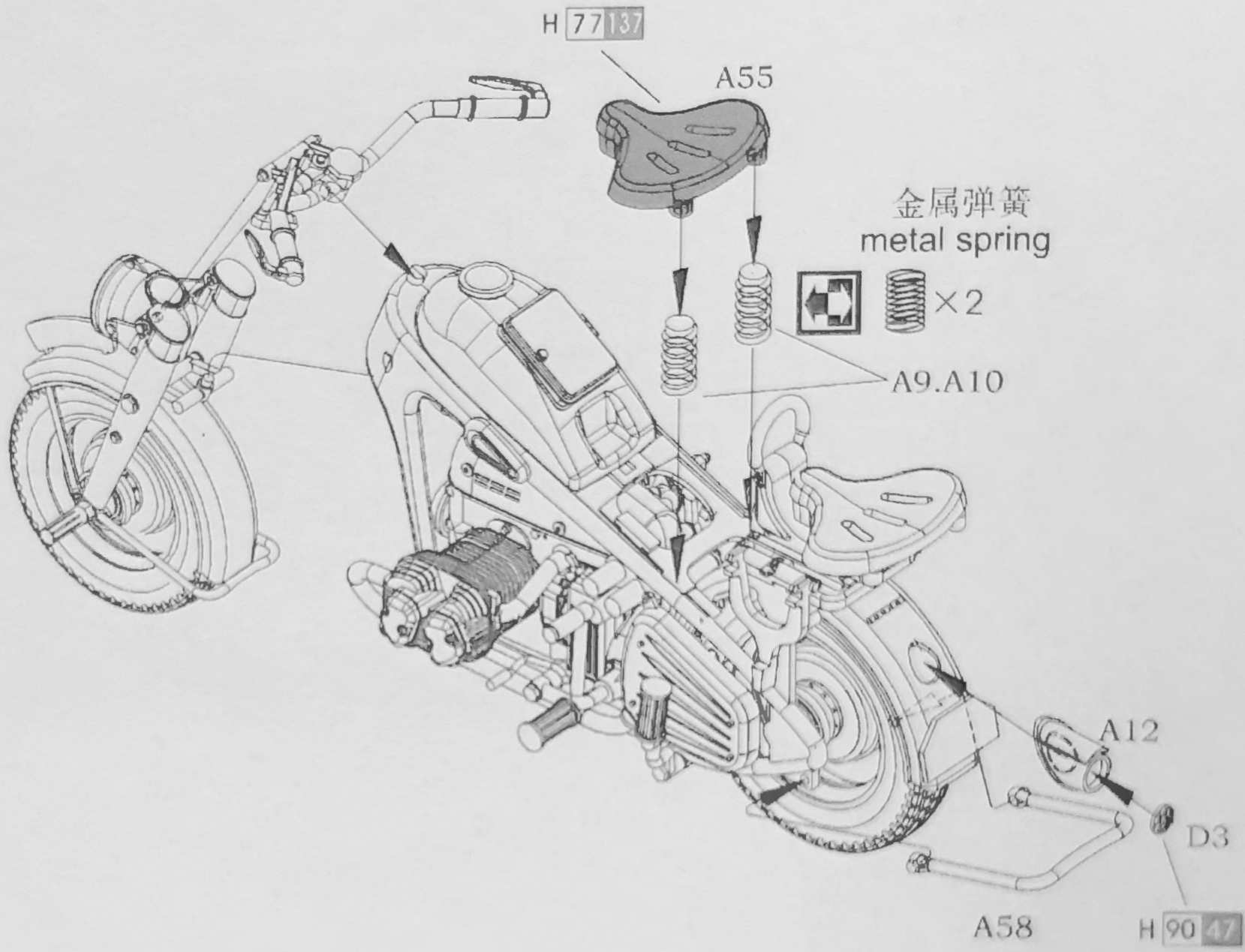
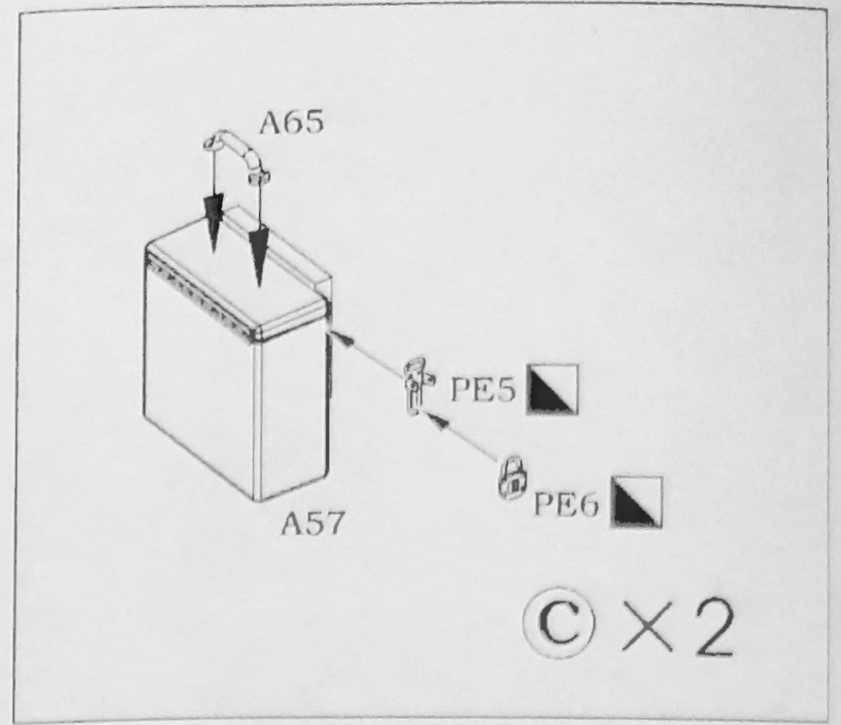
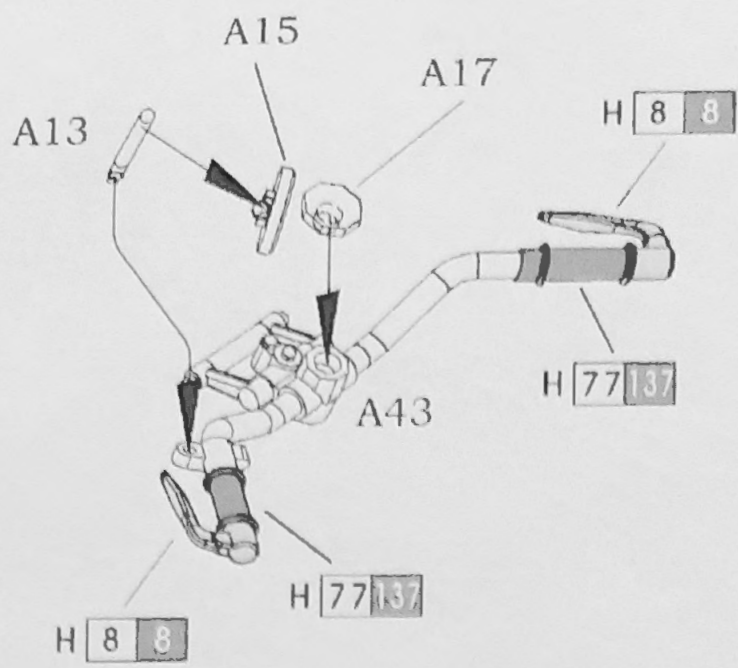

A 非洲軍團1942 Afrikakorps 1942

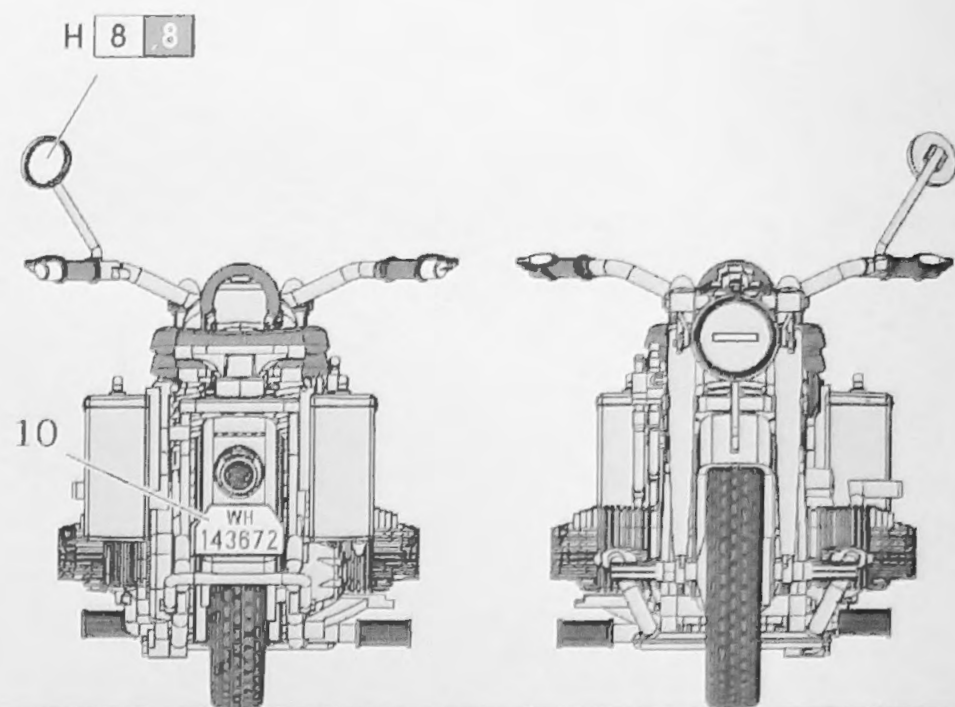
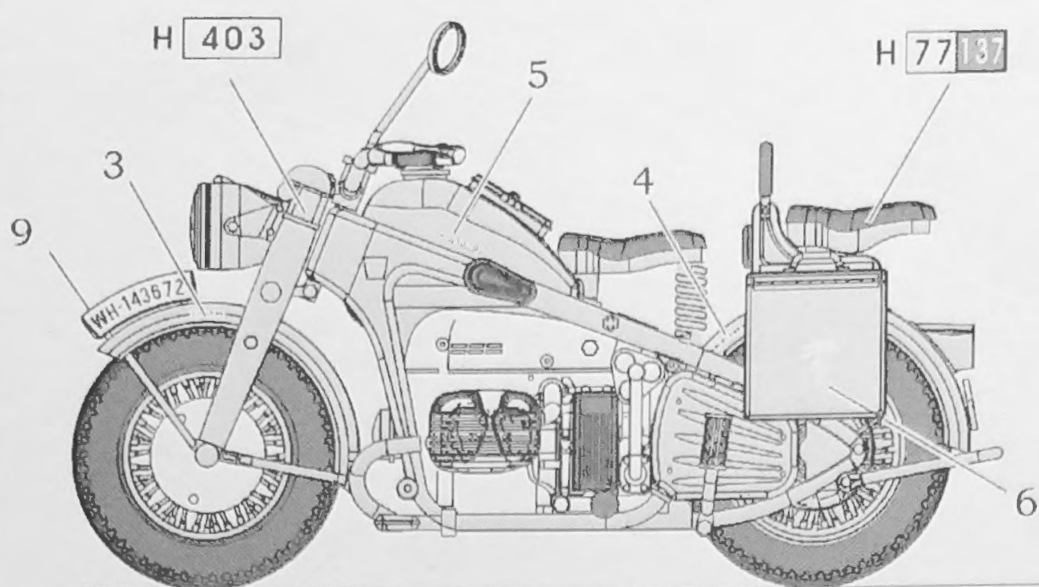

B 空軍地面部隊 Luftwaffe

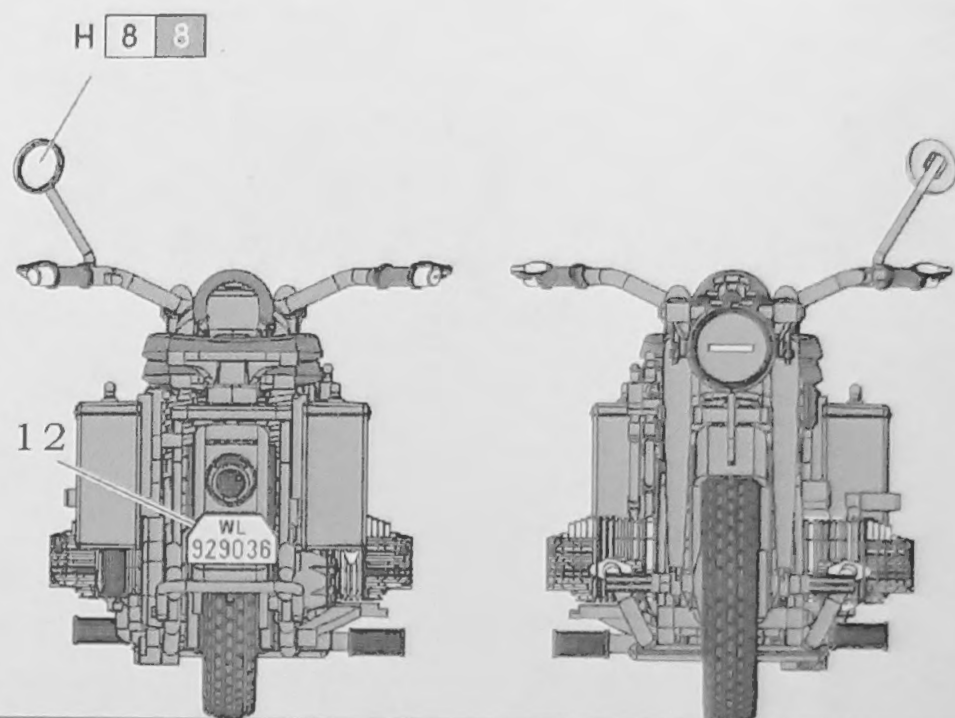
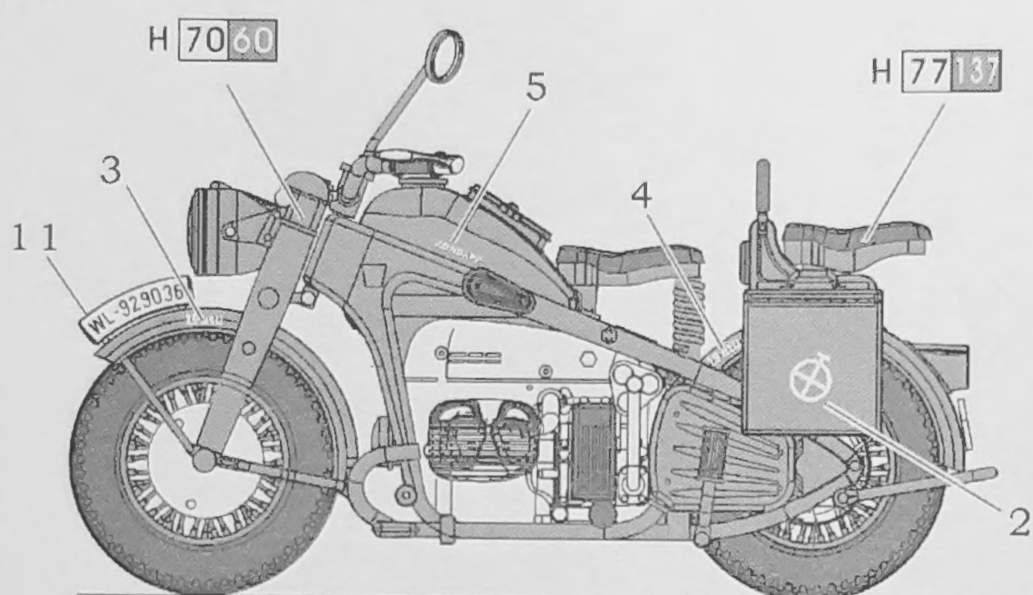

C 武裝黨衛軍 Waffen-SS

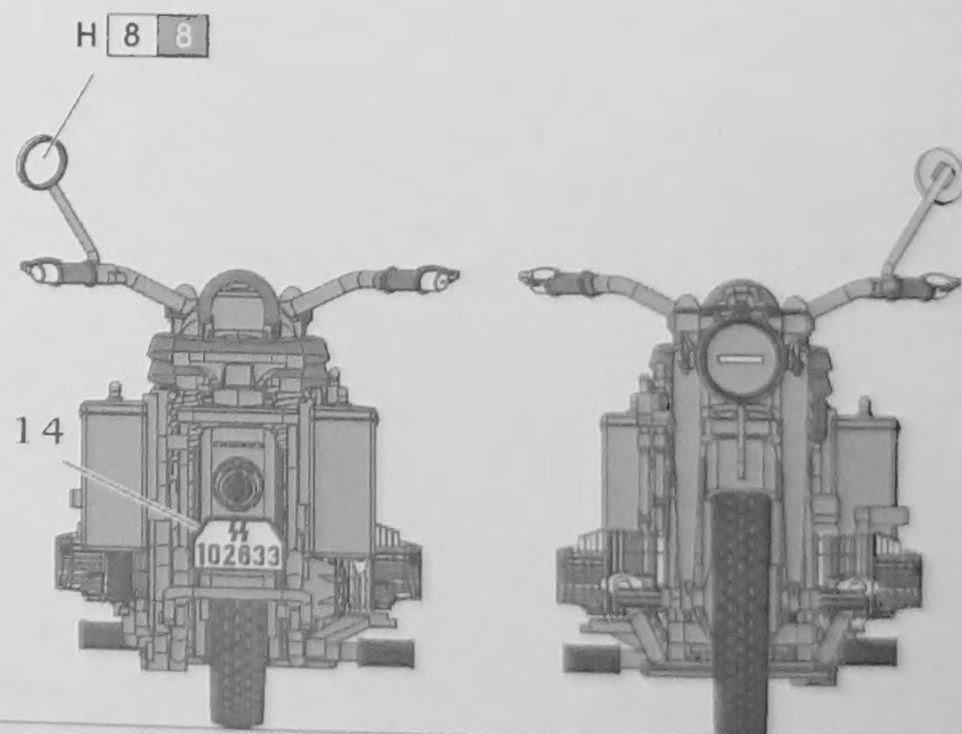
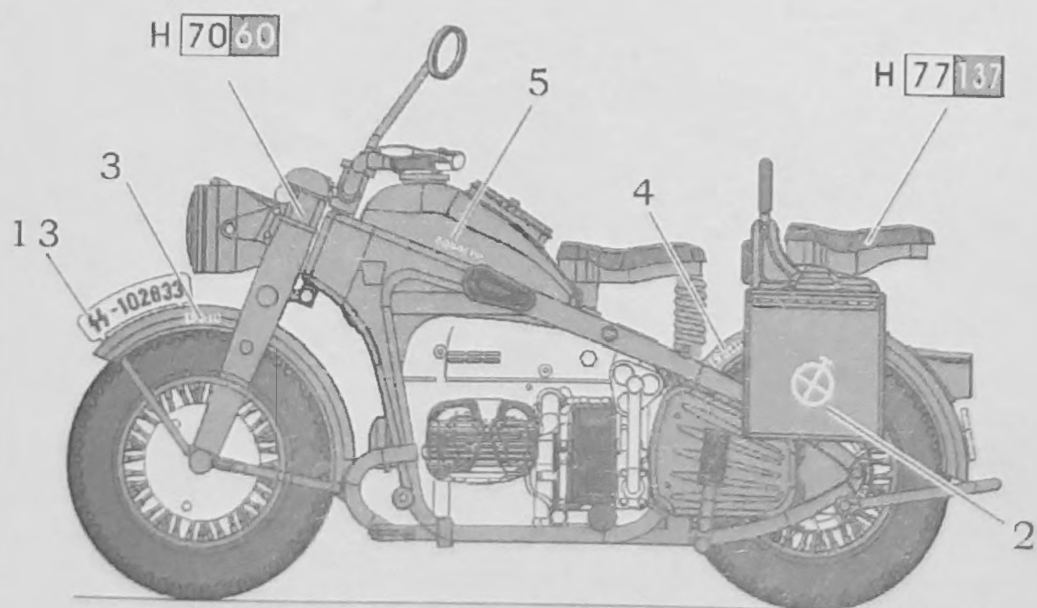

D 德國國防軍 Wehrmacht

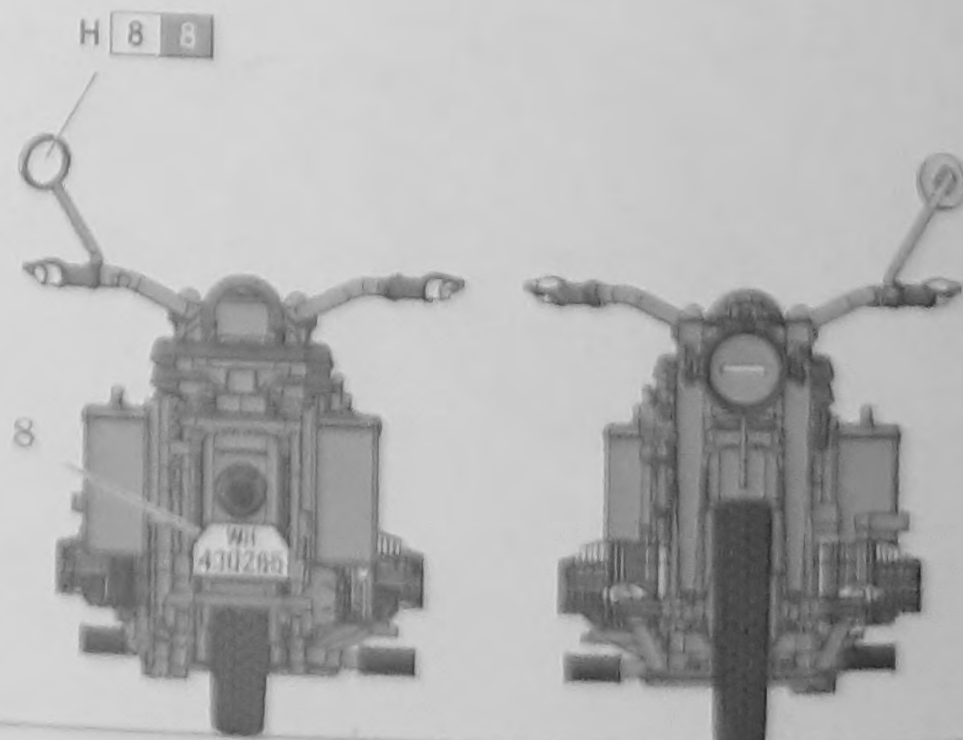
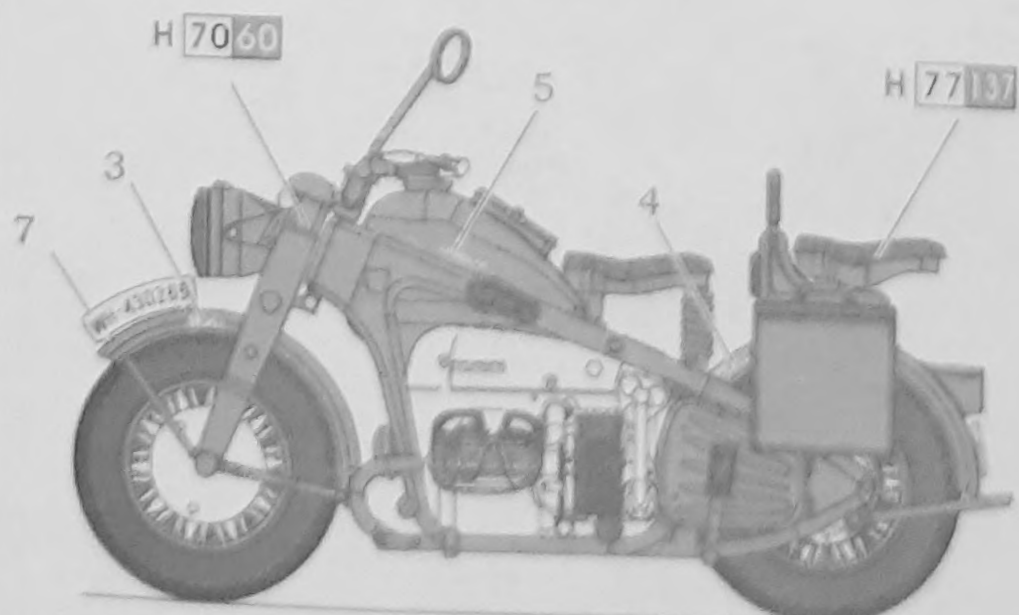

Item numbers of the kits in the same series.

L3508 WWII GERMAN ZUNDAPP KS750 WITH SIDECAR

二战德军尊达普 KS750 三轮摩托车

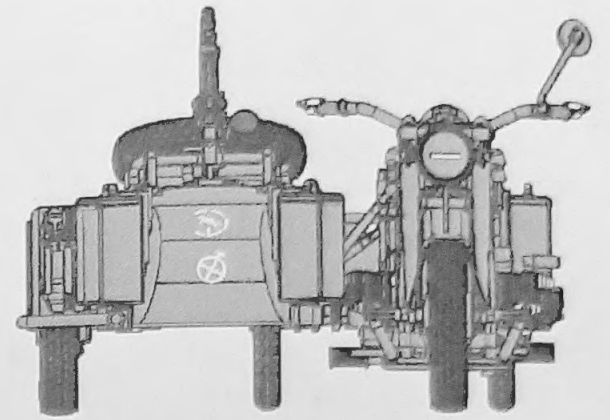
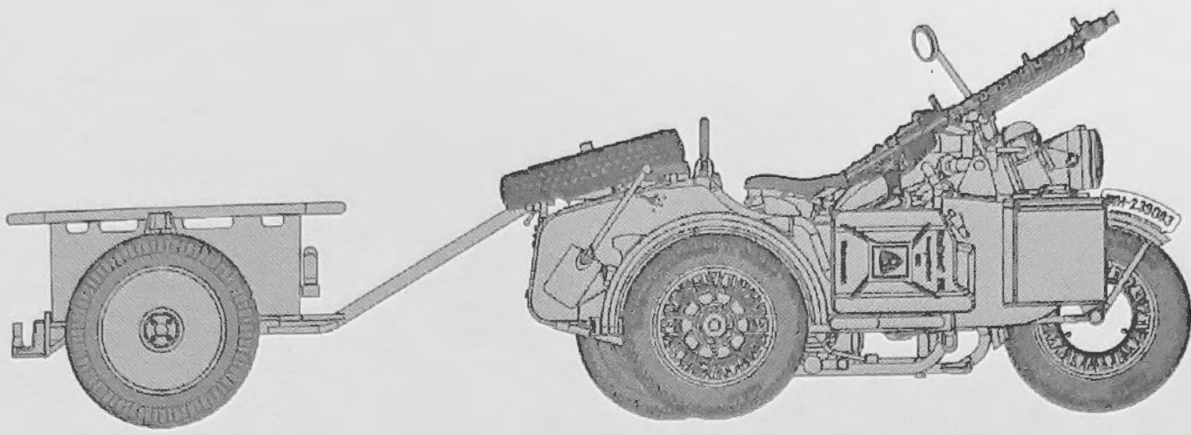
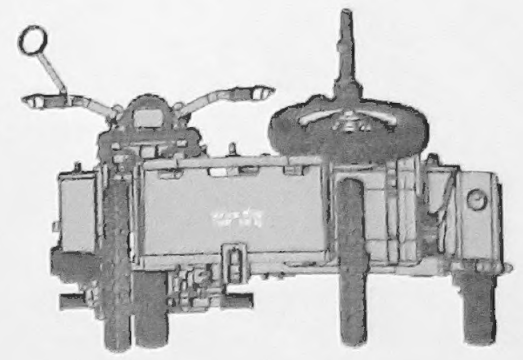
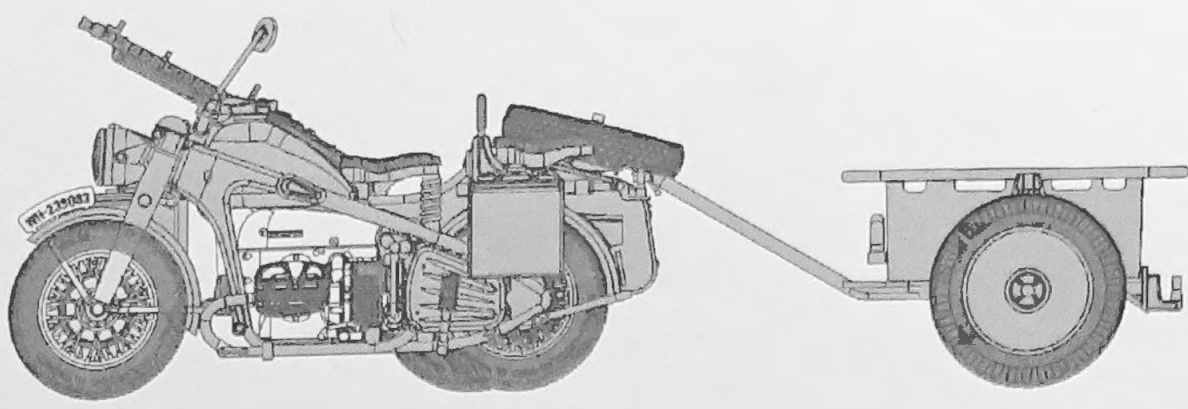

L3509 WWII GERMAN R75

二战德军R75重型摩托车

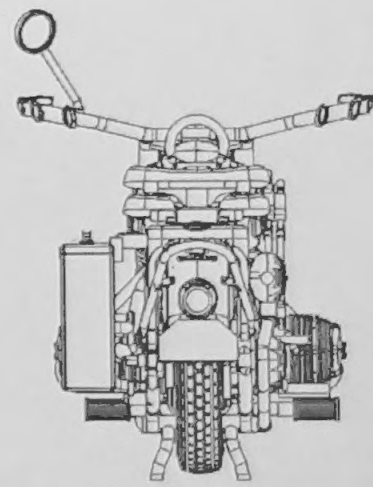
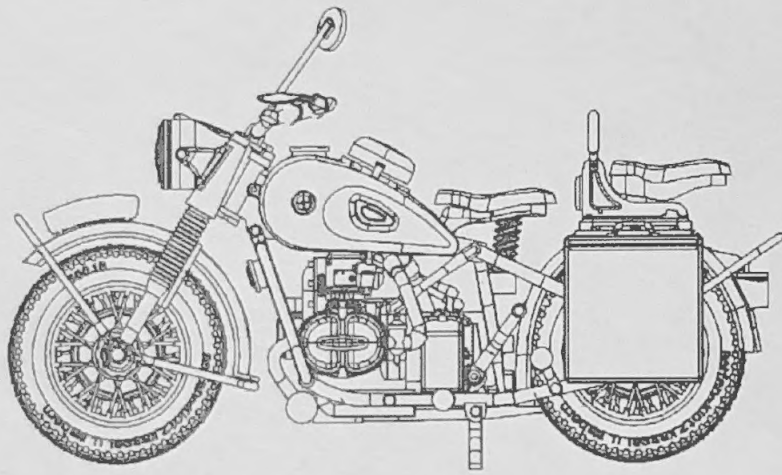

L3510 WWII GERMAN R75 WITH SIDECAR

二战德军宝马R75三轮摩托车

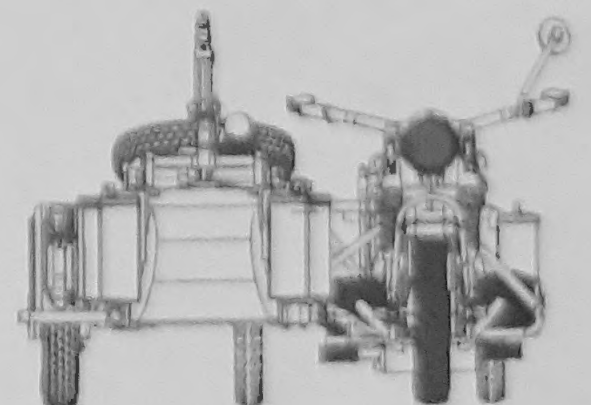
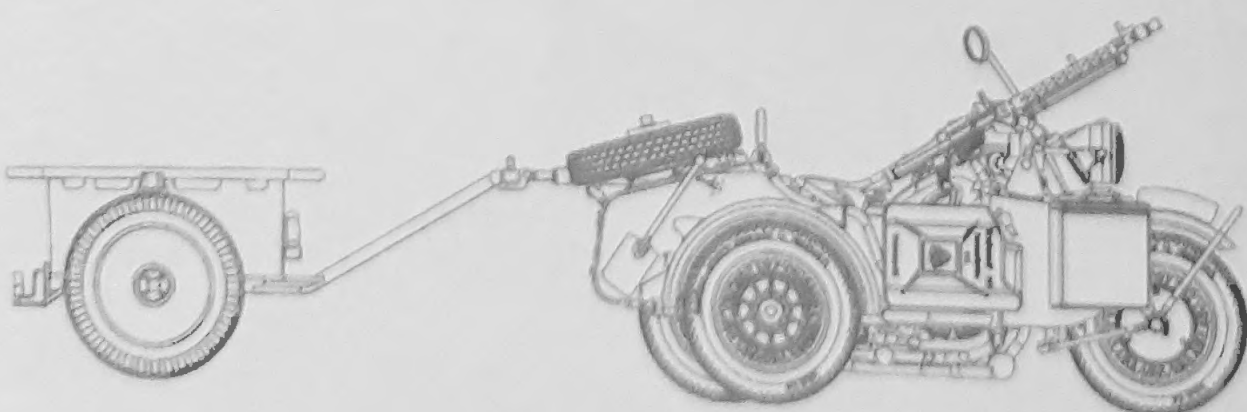
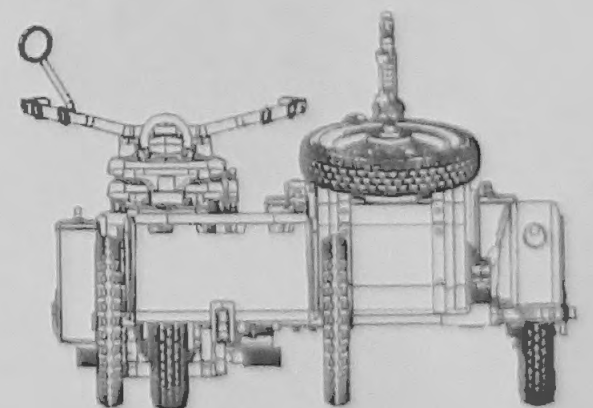
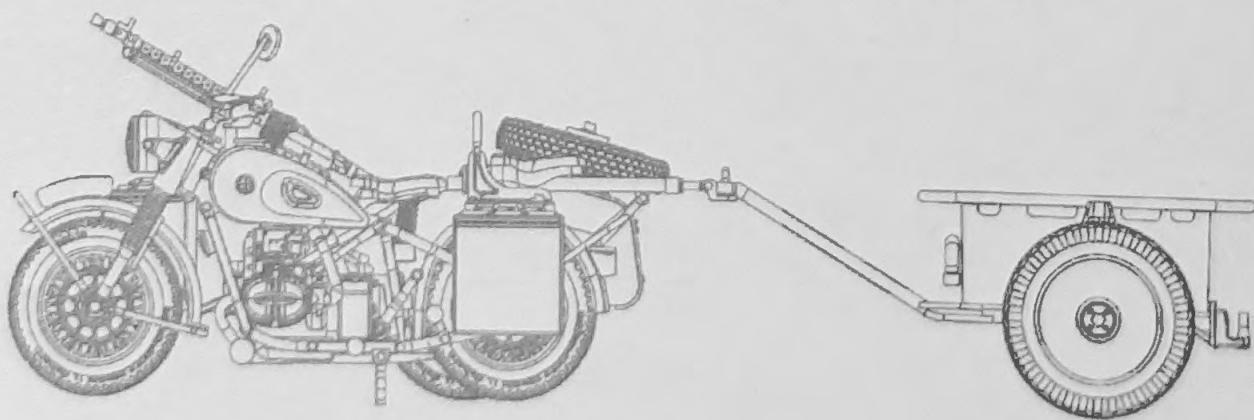

Amendment 说明书更正布告

L3507 套件说明书所含内容改正如下：

此套件中所含水贴纸数量为1枚，可用于2款双轮摩托车涂装，请注意。

敬请谅解。

Please fine the amendment for the instruction of L3507 as follow:

The kit only contains 1 piece of decal for 2 motorcycles.

Please note it and sorry for the mistake.

