

## Do 17Z-10

### Германский ночной истребитель II MB

В начале 30-х годов в мире возникла идея создания скоростного бомбардировщика, который мог бы обогнать современные ему истребители-бипланы. Одним из воплощений этой концепции стал двухмоторный бомбардировщик Do 17, разработанный германской фирмой Дорнье Флюгцугверке.

С начала 1939 г. началось производство самолетов Do 17Z с новой носовой частью типа "Waffenkopf", на которых были установлены двигатели воздушного охлаждения Bramo 323 Fafnir.

В 1940 г. были выпущены 9 ночных истребителей Do 17Z-10 Kauz II. На этих самолетах с мощным вооружением были установлены приборы инфракрасного обнаружения Spanner-Anlage. Do 17Z-10 служили в ночной истребительной группе II/NJG 1 до начала 1941 г.

#### Тактико-технические характеристики Do 17Z-10

Длина, м .....	16,54
Размах крыла, м .....	18,0
Взлетный вес, кг .....	8510
Двигатель .....	2xBramo 323P, 1000 hp
Максимальная скорость, км/ч .....	420
Потолок, м .....	8000
Дальность, км .....	2000
Вооружение .....	1x20-мм пушка MG 151, 4x7,92-мм пулемета MG 17, 1x7,92-мм пулемет MG 15

#### ВНИМАНИЕ!

Перед сборкой внимательно прочитайте руководство по монтажу. Каждая деталь пронумерована. Соблюдать последовательность монтажа. Необходимые рабочие инструменты: нож и напильник для зачистки деталей; резиновая лента, клейкая лента и зажимы для сушки белила для прижима склеиваемых деталей. Детали из пластика очистить в растворе мягкого моющего средства и высушить на воздухе для того, чтобы краска и переводные картинки лучше прилипали. Перед приклеиванием проверить, подходят ли детали; клей наносить экономно. Хром и краску удалить с поверхностей склеивания. Небольшие детали покрасить перед тем, как они будут удалены из рамок. Краску необходимо хорошо просушить, только после этого продолжать сборку. Каждую соответствующую переводную картинку отдельно вырезать и примерно на 20 секунд окунуть в теплую воду. На обозначенном месте картинку отделить от бумаги и прижать промокательной бумагой.

#### ИСПОЛЬЗУЕМЫЕ КРАСКИ / USED COLORS:

	Model Master		
<b>A</b>	<b>1749</b>	Черный, матовый	Flat Black
<b>B</b>	<b>1768</b>	Белый, матовый	Flat White
<b>D</b>	<b>2080</b>	Черно-зеленый RLM 70	Schwarzgrun RLM70
<b>G</b>	<b>2079</b>	Черно-серый, матовый	Schwarzgrau RLM66
<b>H</b>	<b>2071</b>	Серо-зеленый RLM02	Grau RLM02
<b>J</b>	<b>1781</b>	Алюминий, полуматовый	Aluminum

## Do 17Z-10

### WWII German Night Fighter

In the beginning of 30s it was appeared in the world an idea of high-speed bomber that could outstrip contemporary fighters. One of the objectifications of this conception became the twin-engine bomber Do 17 designed by a German Dornier Flugzeugwerke company.

Since the beginning of 1939 it were produced Do 17Z planes with new "Waffenkopf" type nose part and air-cooled Bramo 323 Fafnir engines.

In 1940 it were produced 9 Do 17Z-10 Kauz II night fighters. Spanner-Anlage infrared night vision devices were installed in these planes with powerful armament. They served in the night fighter unit II/NJG 1 up to the beginning of 1941.

#### Tactical and Technical Specifications of Do 17Z-10

Length, m .....	16,54
Span, m .....	18,0
Start Weight, kg .....	8510
Engine .....	2xBramo 323P, 1000 hp
Max. Speed, km/h .....	420
Service ceiling, m .....	8000
Range, km .....	2000
Armament ..	1x20-mm MG 151, 4x7,92 mm MG 17, 1x7,92 mm MG 15

#### CAUTION!

Read the instructions thoroughly prior to assembly. Each component is numbered. Adhere to specified sequence of assembly. Tools required: knife and file for removal of components from frame; rubber bond, adhesive tape and clothes pegs for clamping components together after applying adhesive. Clean plastic components in a mild detergent solution and allow to air-dry so that paint and transfers adhere better. Prior to applying adhesive, check to see whether the components fit together; apply adhesive sparingly. Remove chrome and paint from the contact surfaces. Paint small components before removing them from the frame. Allow paint to dry well, and only then continue to assemble. Cut out each transfer individually and immerse in warm water for approx. 20 seconds. Slide transfer off paper and into designated position, then press on with blotting paper.

	Model Master		
<b>K</b>	<b>1780</b>	Сталь	Steel
<b>L</b>	<b>1795</b>	Темный металл	Gun Metal
<b>M</b>	<b>1785</b>	Ржавчина	Rust
<b>N</b>	<b>1705</b>	Красный, матовый	Insignia Red
<b>P</b>	<b>1571</b>	Зеленый, матовый	Flat Green

**01** СТАДИЯ СБОРКИ  
ASSEMBLY STEP

**03** СБОРОЧНАЯ ЕДИНИЦА  
ASSEMBLY UNIT

**A** ИСПОЛЬЗУЕМАЯ КРАСКА  
USED COLOR

**x2** СДЕЛАТЬ ДВЕ ДЕТАЛИ  
MAKE 2 PCS

**■** ПРИ СБОРКЕ НЕ ИСПОЛЬЗУЕТСЯ  
PARTS NOT FOR USE

**\*** СДЕЛАТЬ САМОМУ  
SCRATCH BUILD

**?** ПРОИЗВОЛЬНЫЙ ВЫБОР  
OPTIONAL

**||** ОТРЕЗАТЬ  
CUT OFF

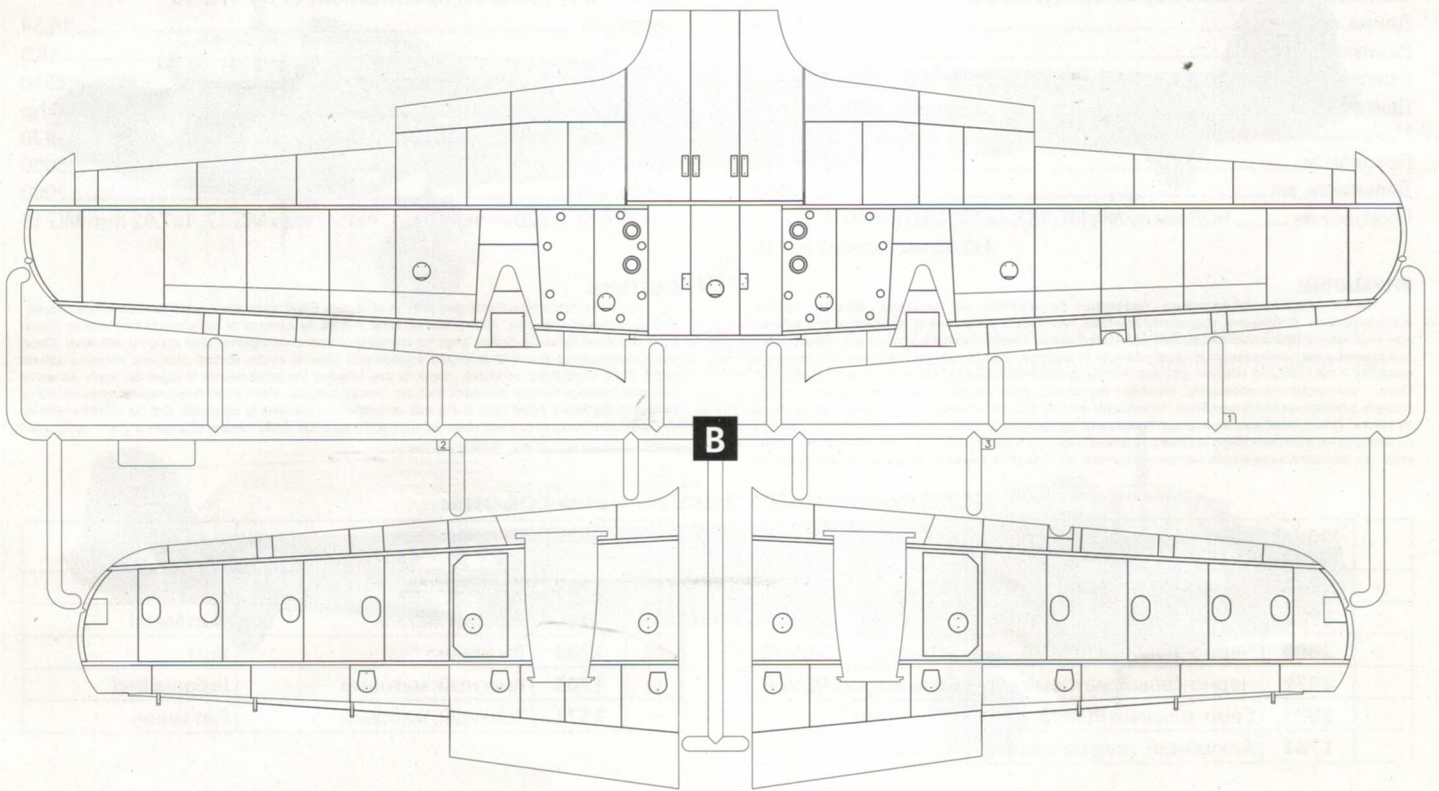
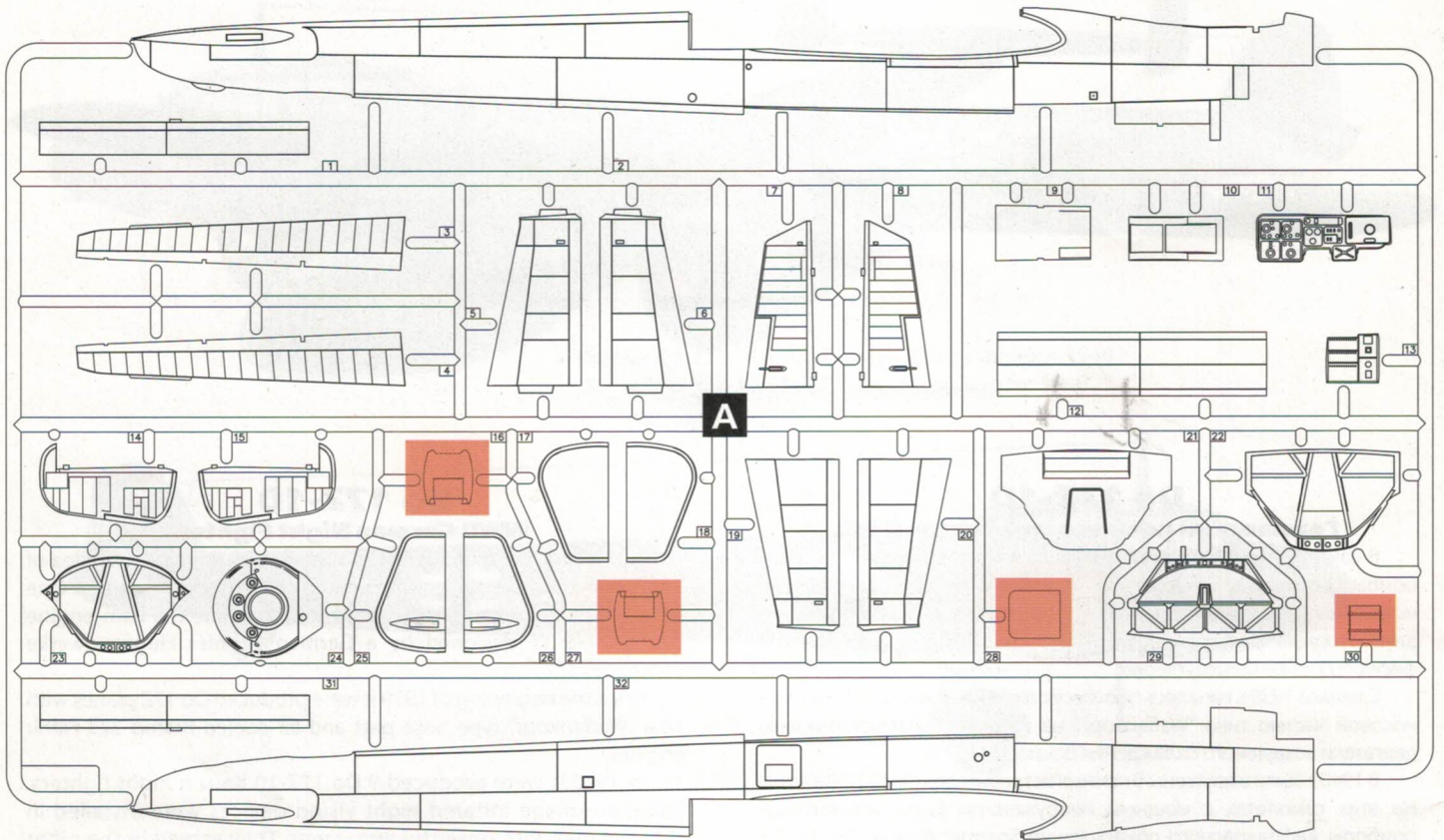

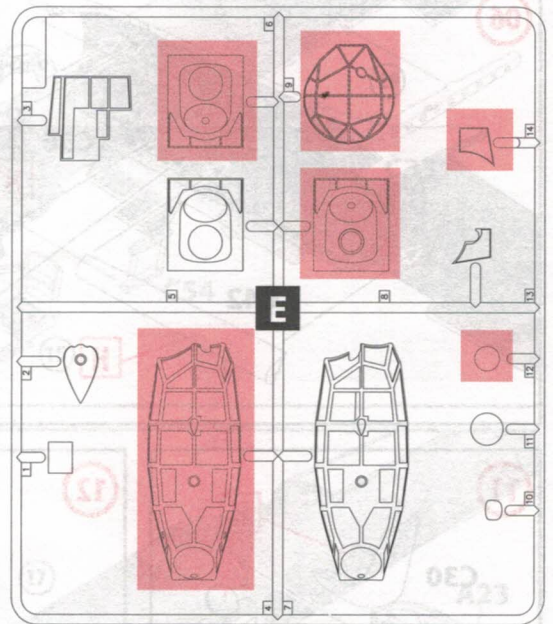
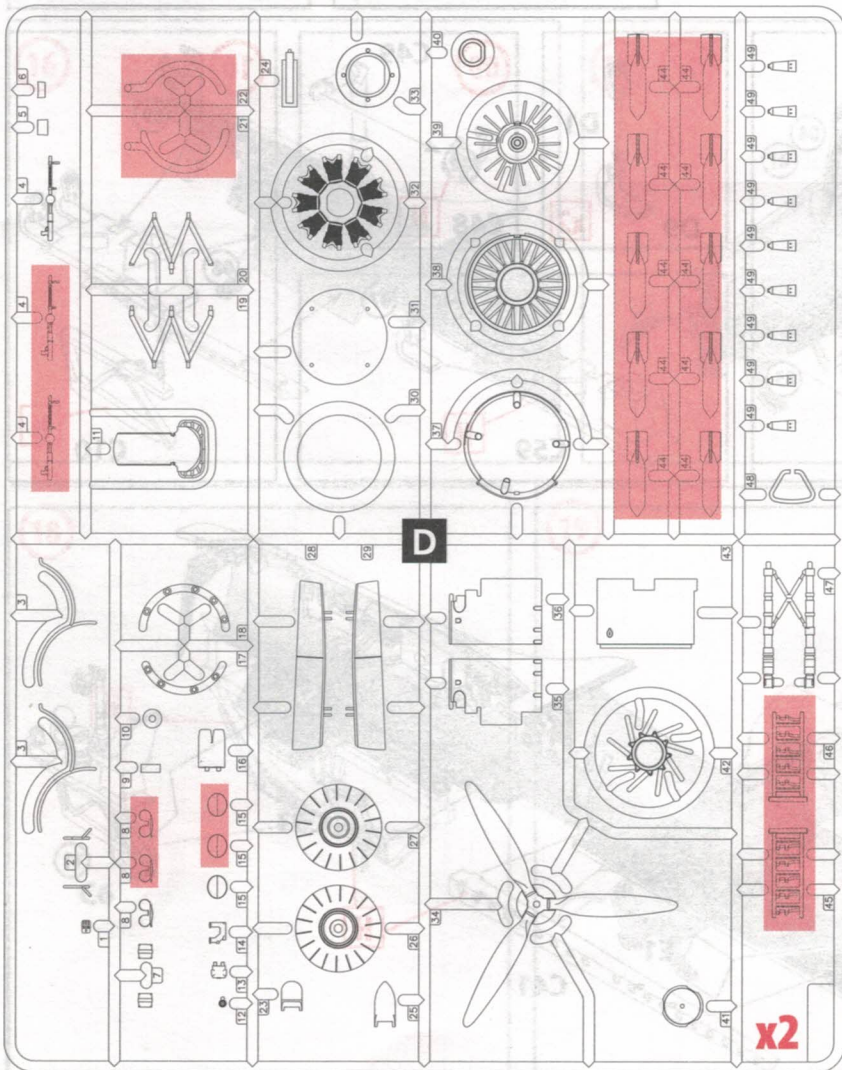
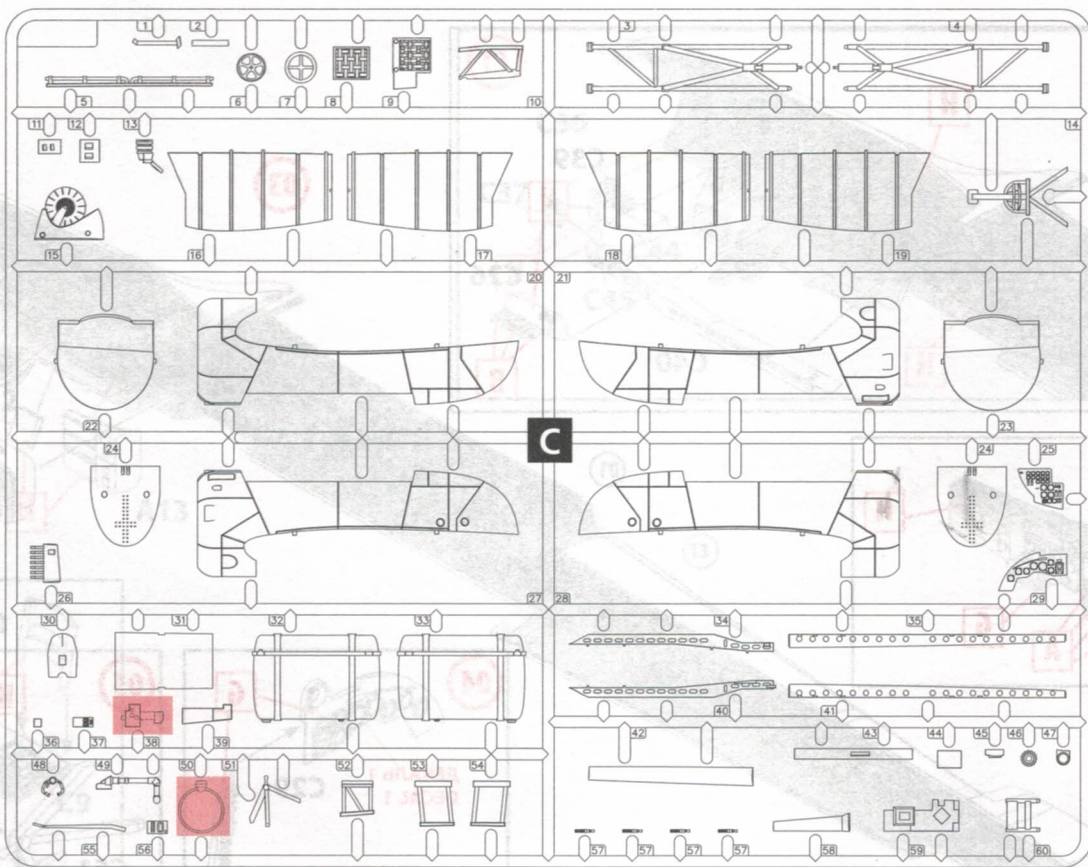

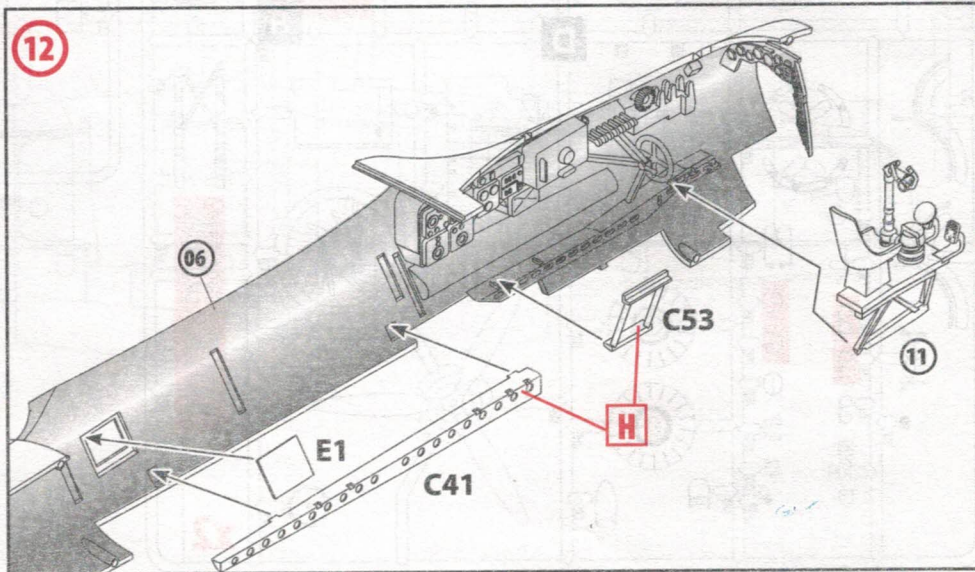
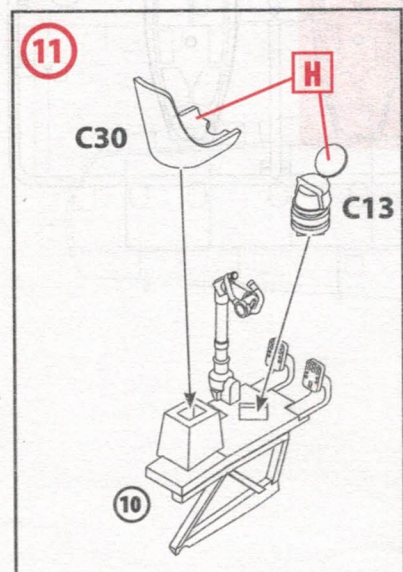
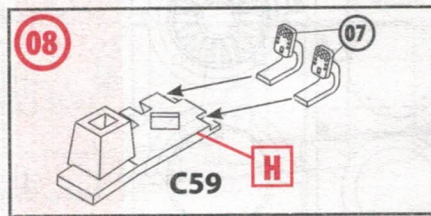
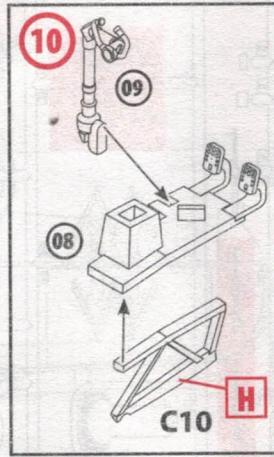
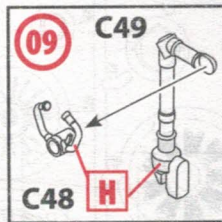
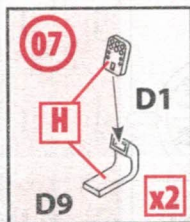
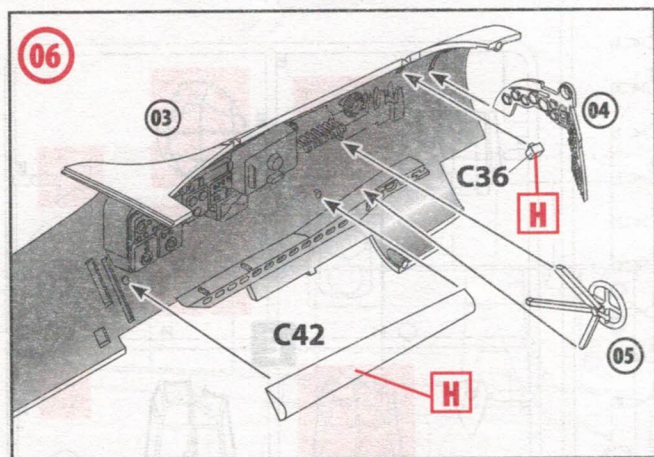
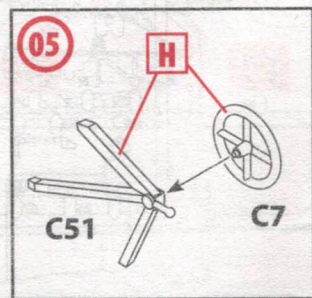
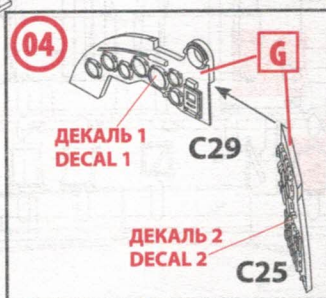
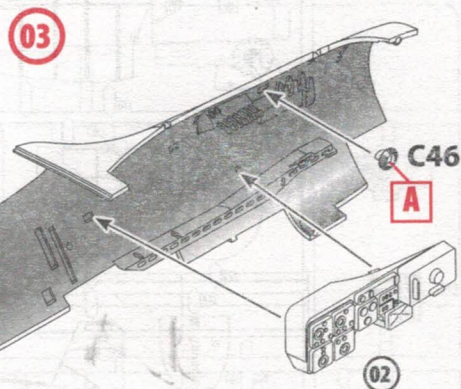
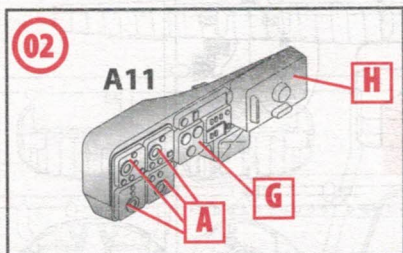
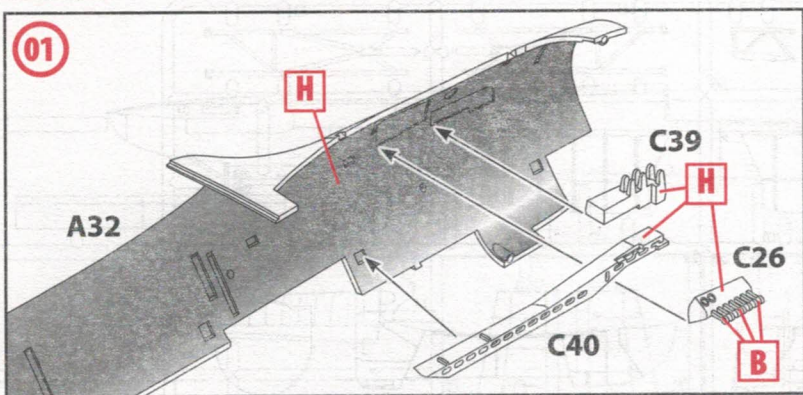

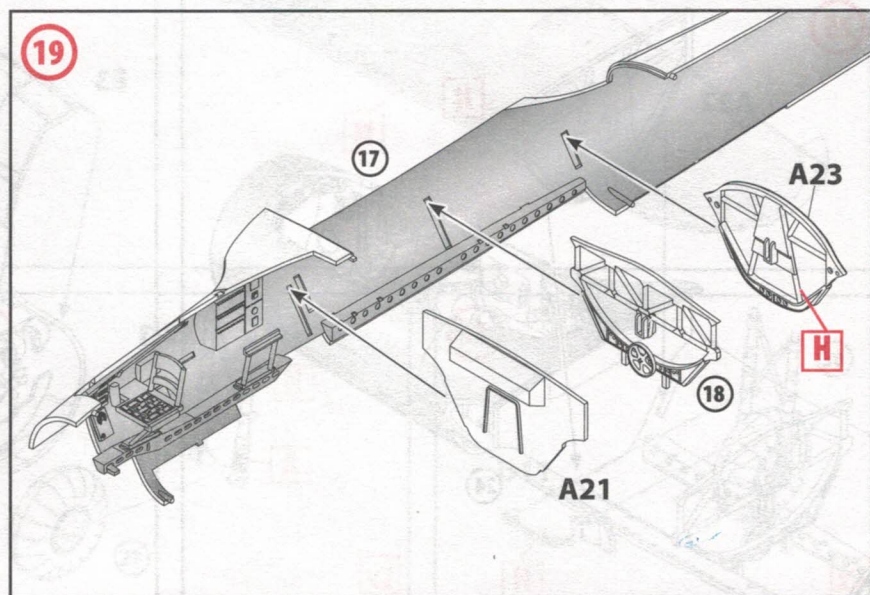
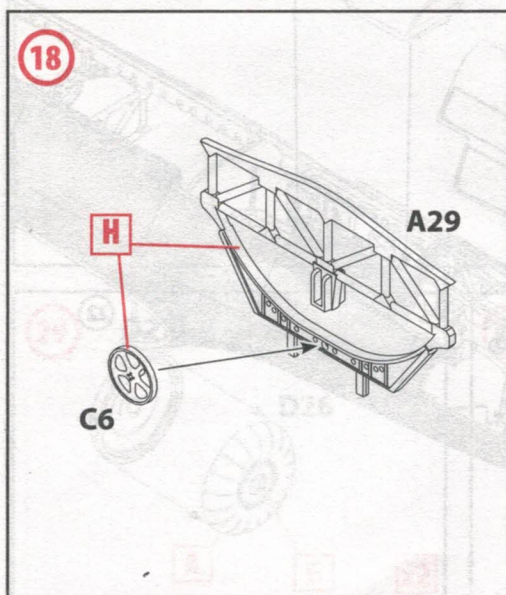
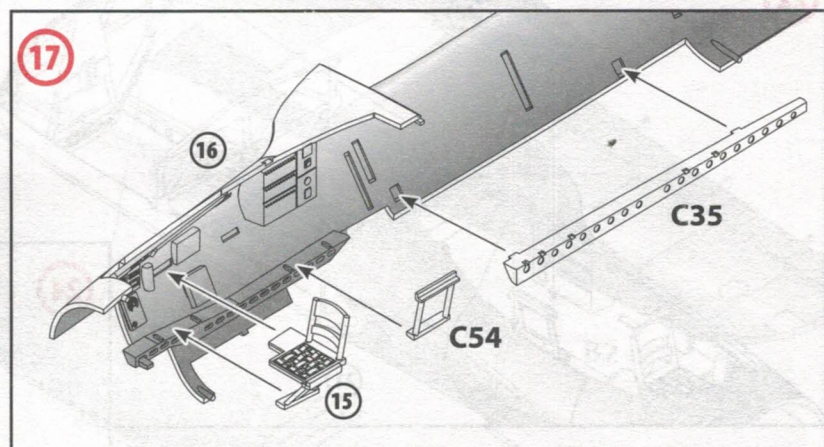
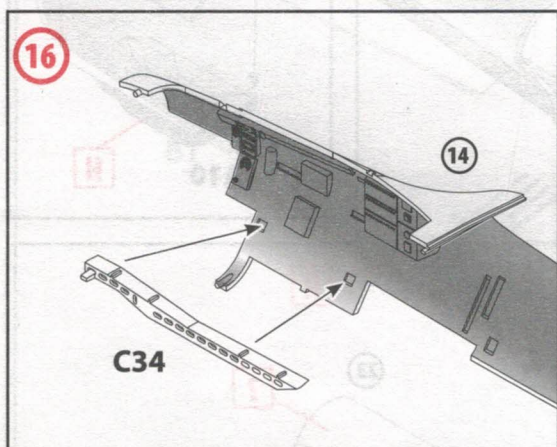
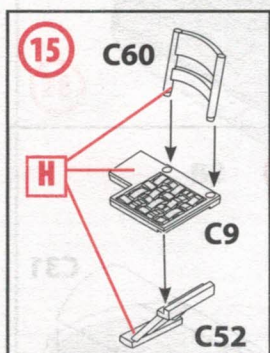
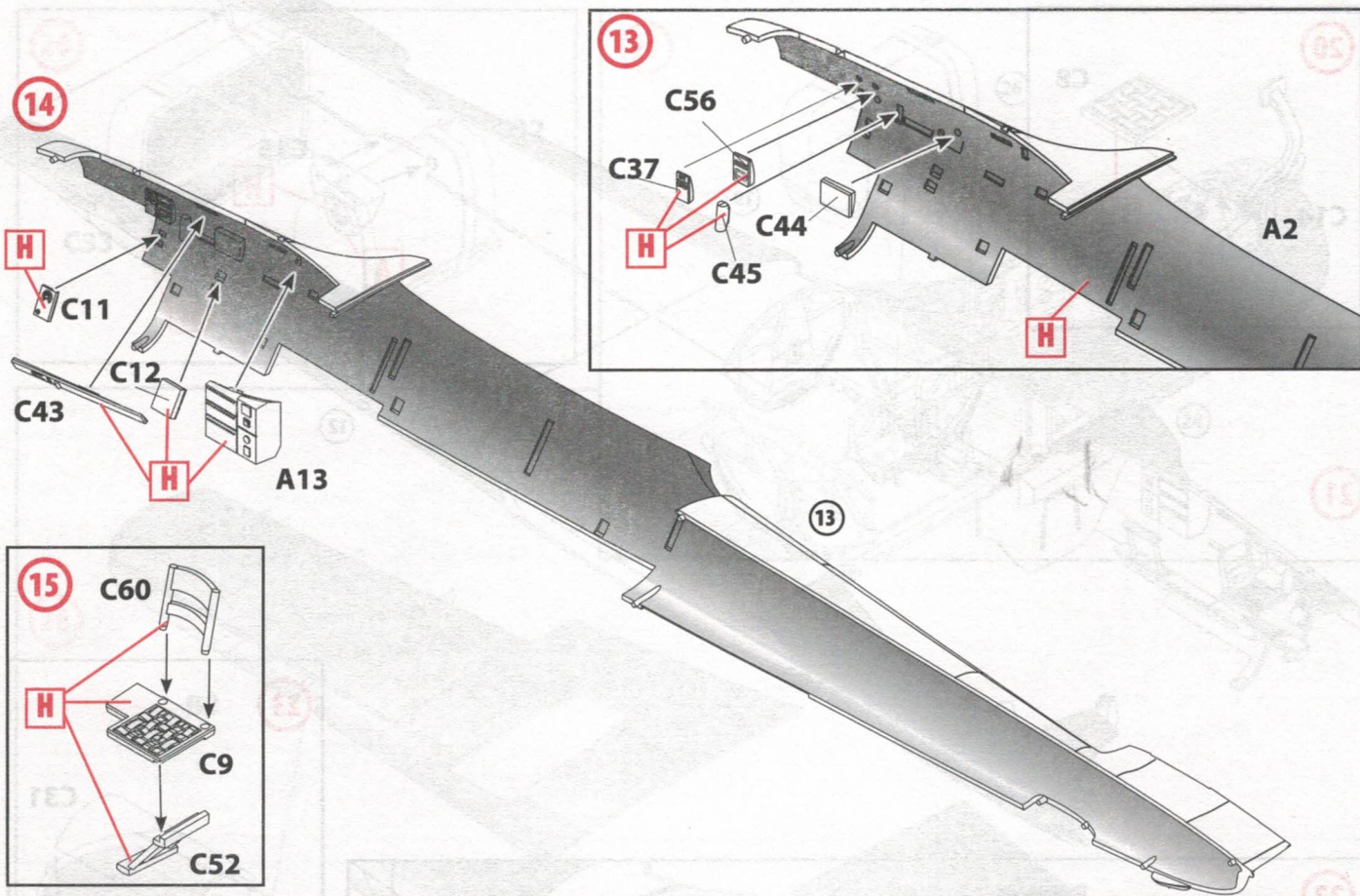

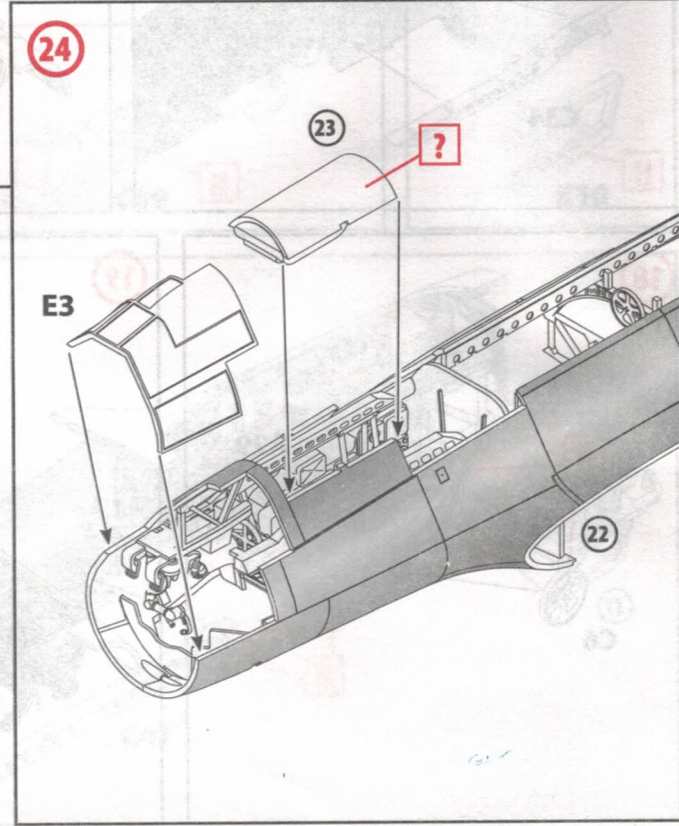
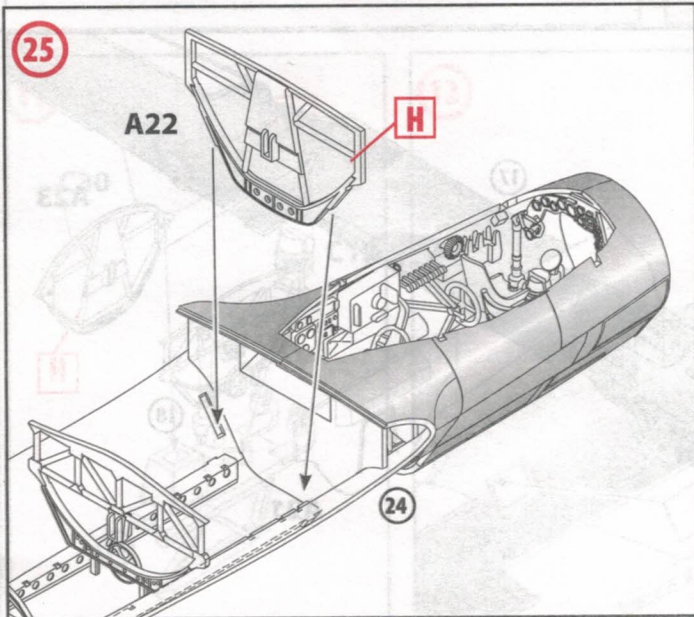
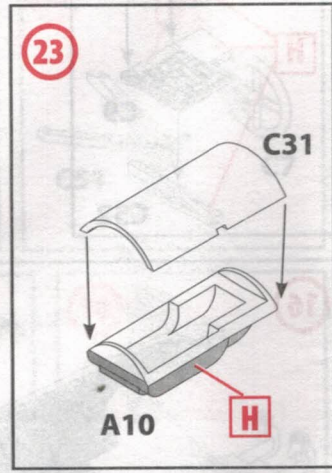
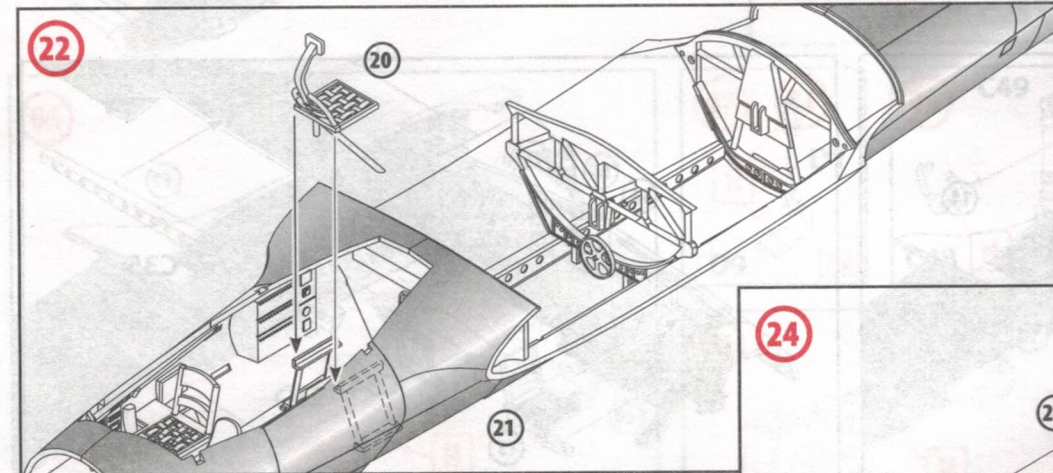
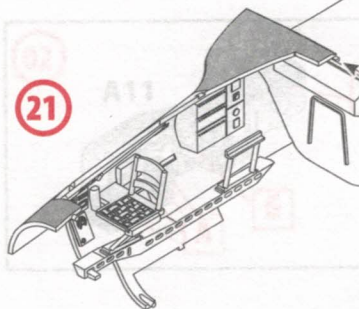
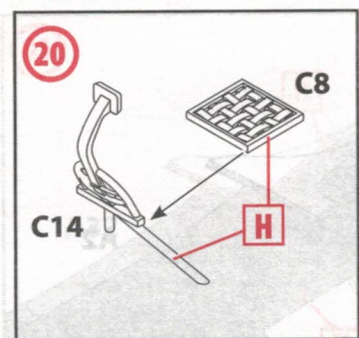

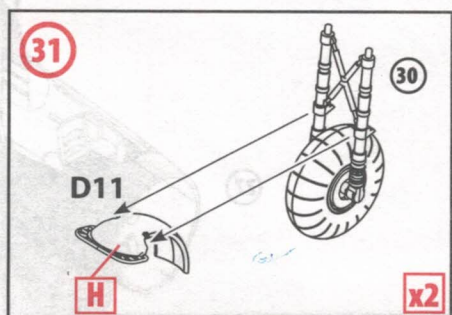
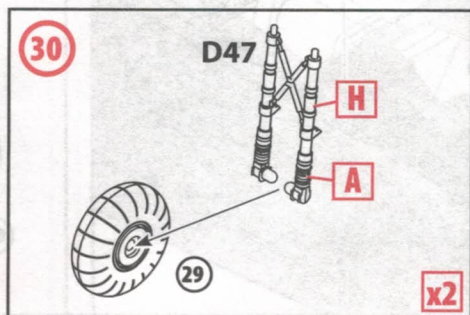
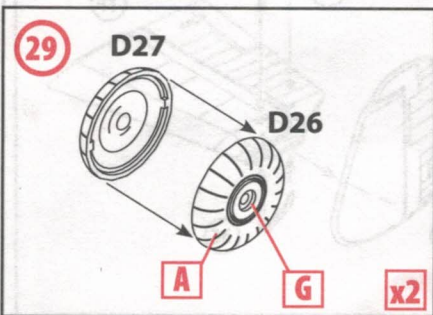
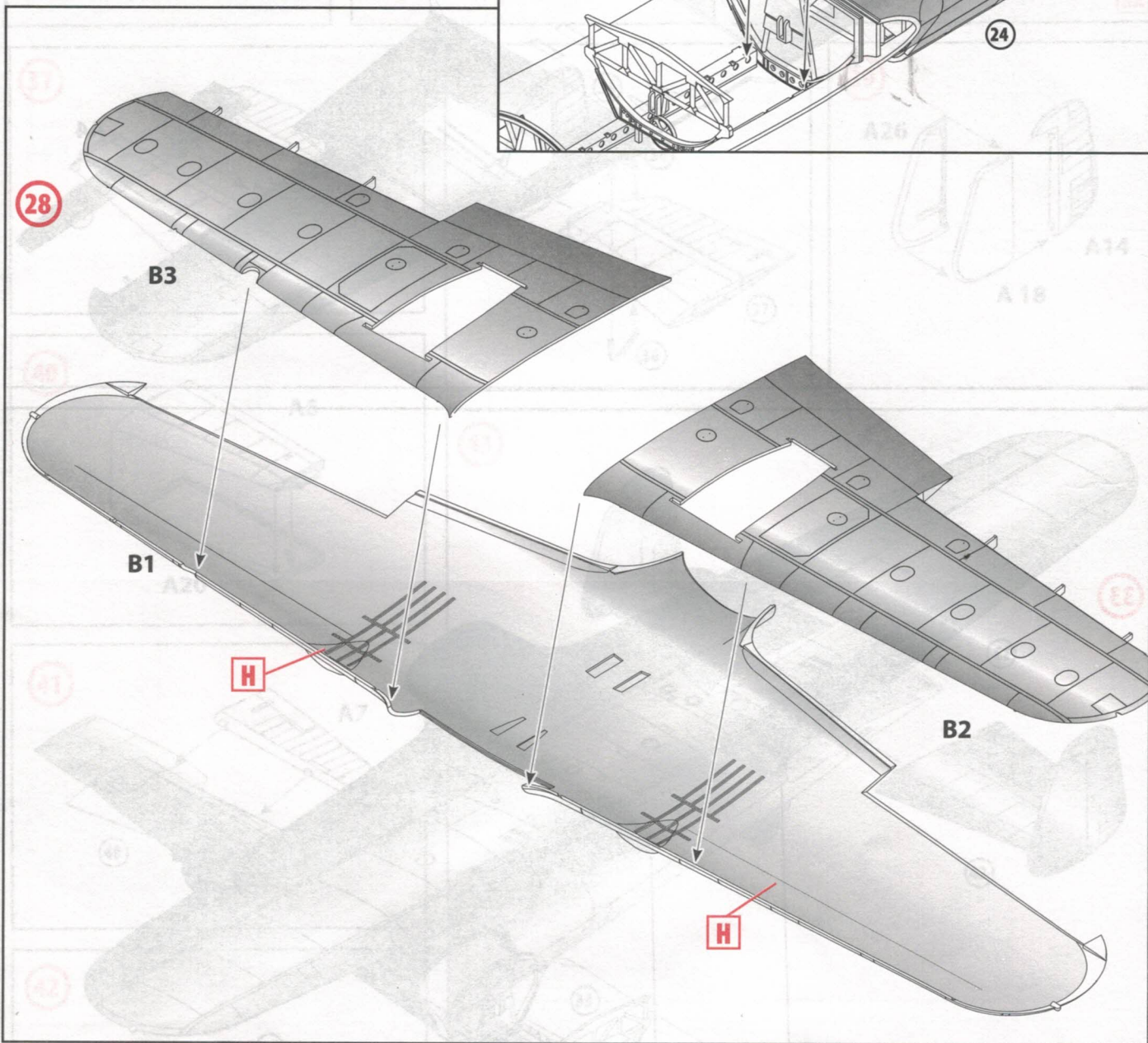
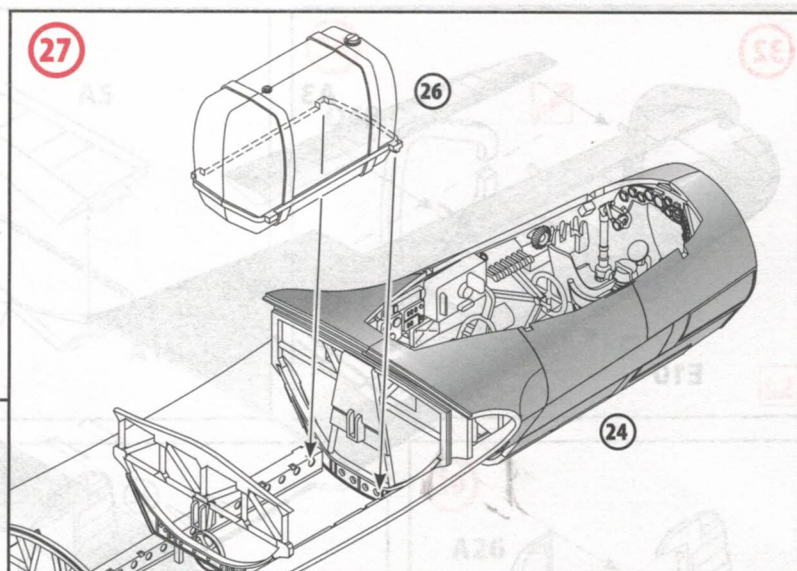
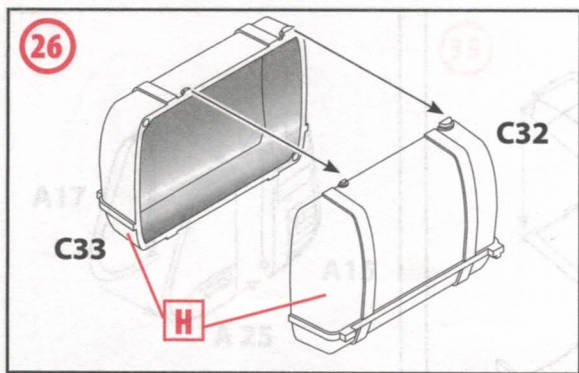

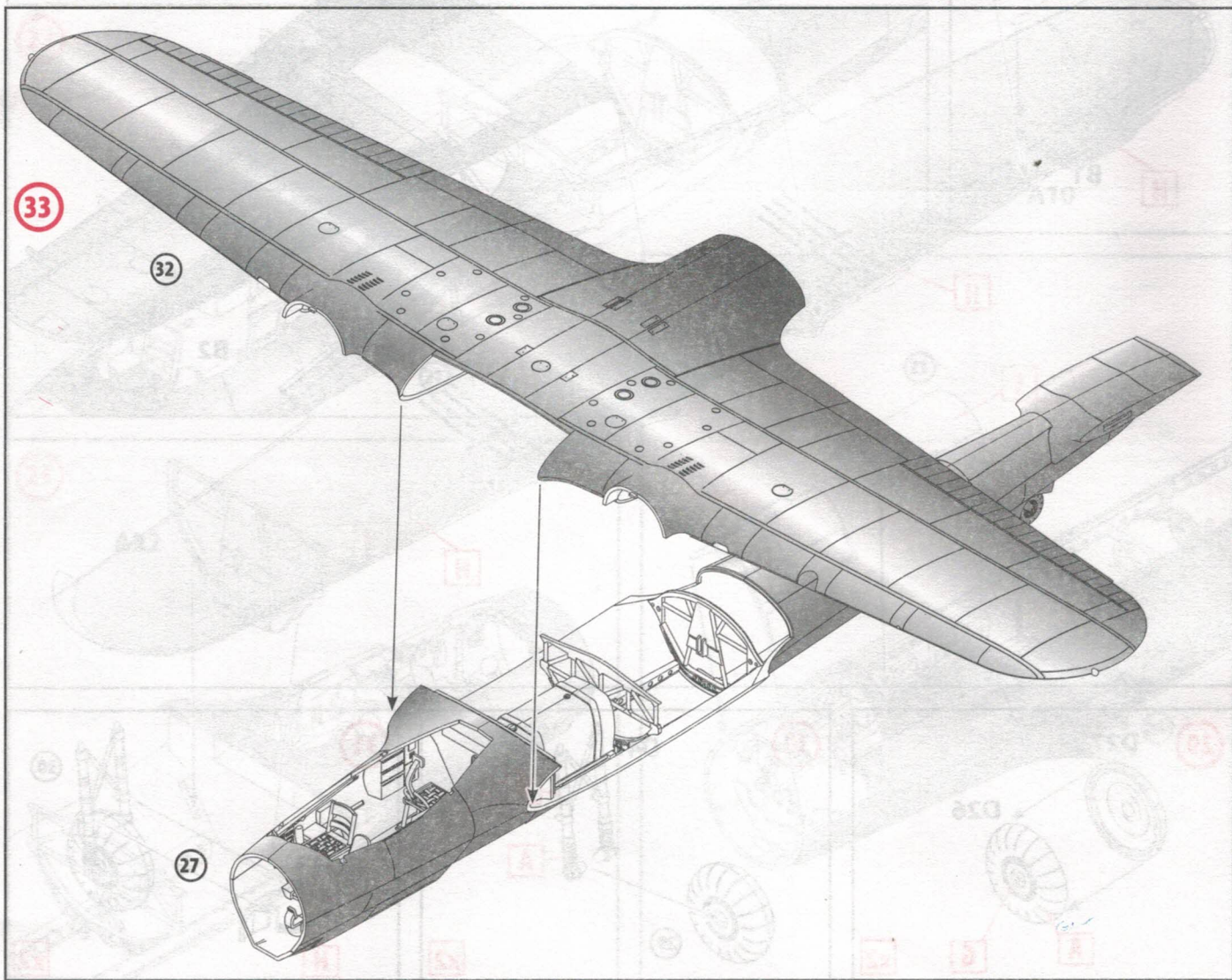
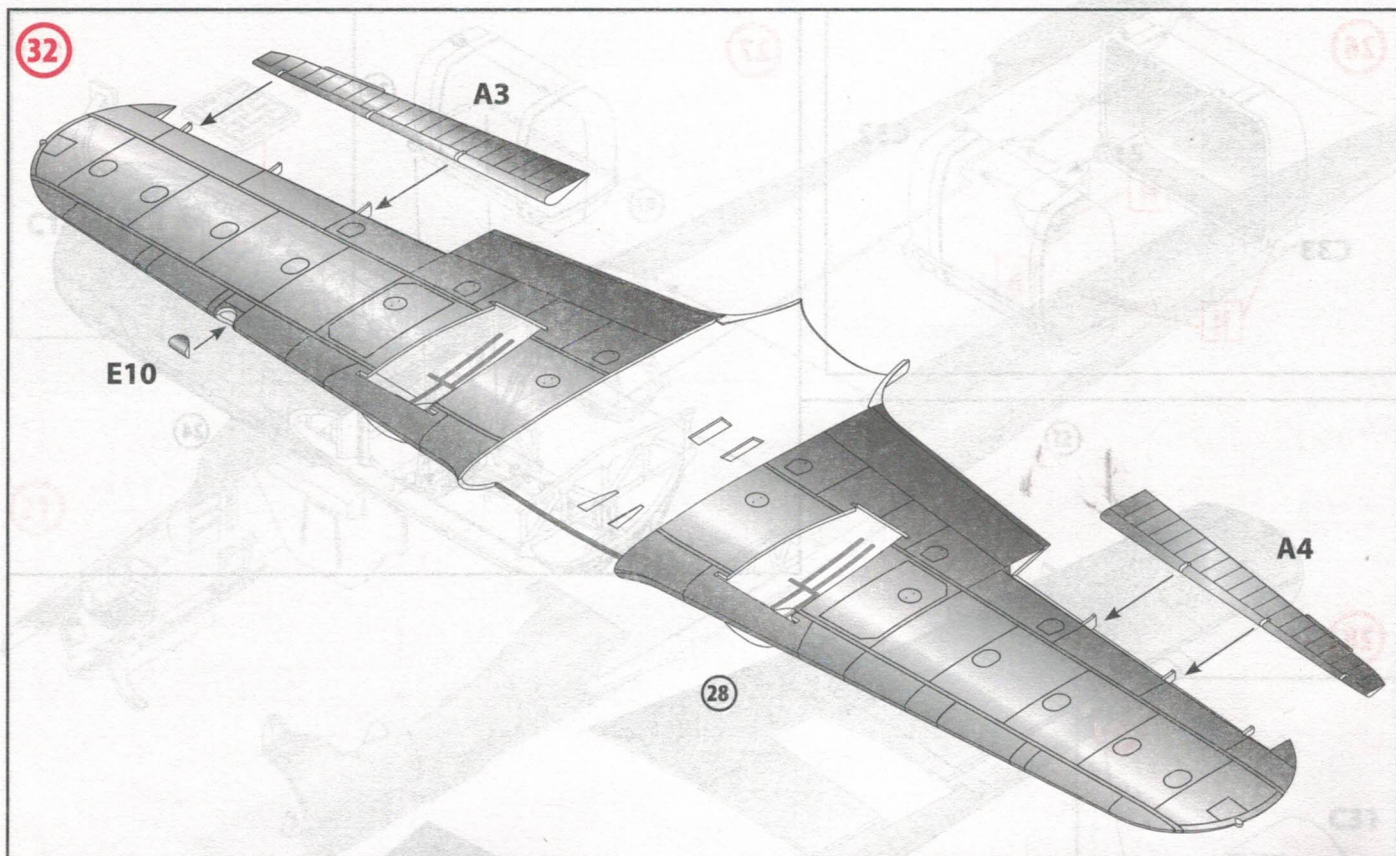



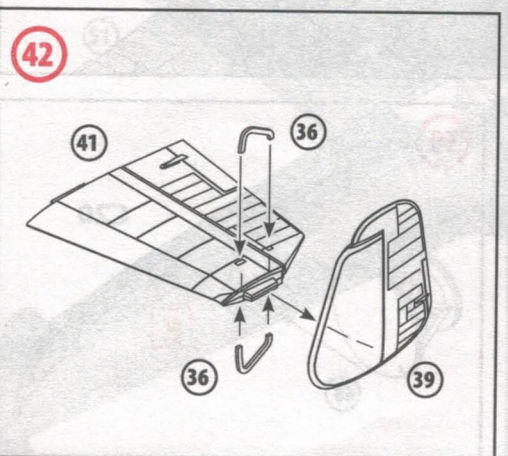
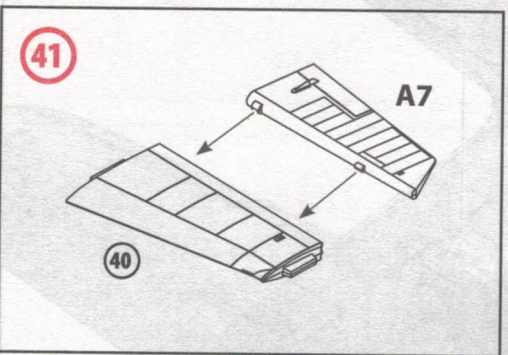
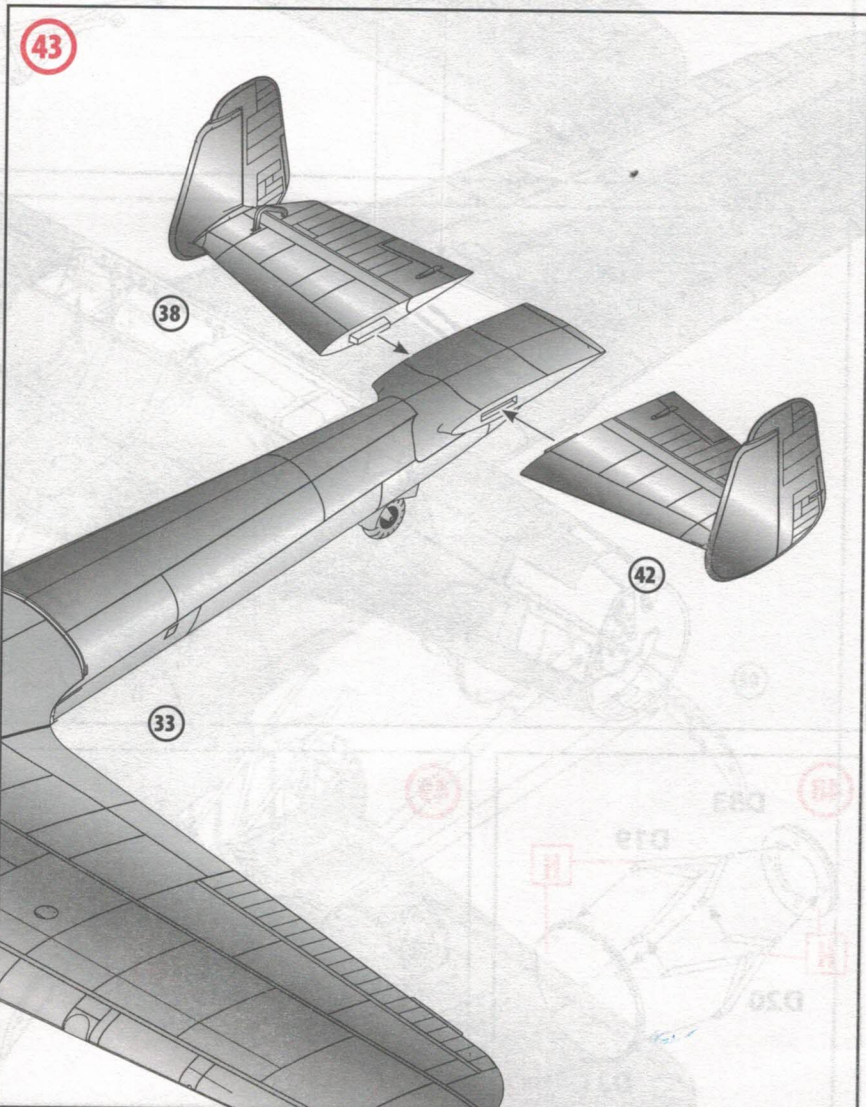
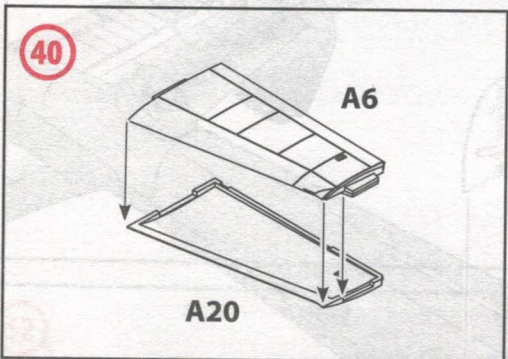
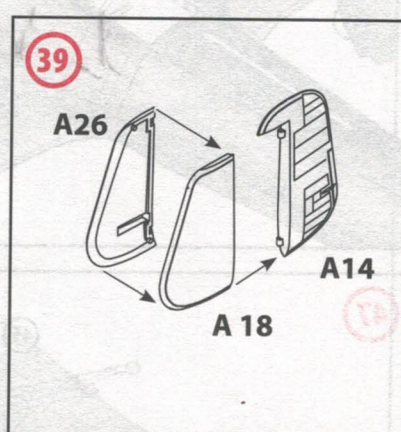
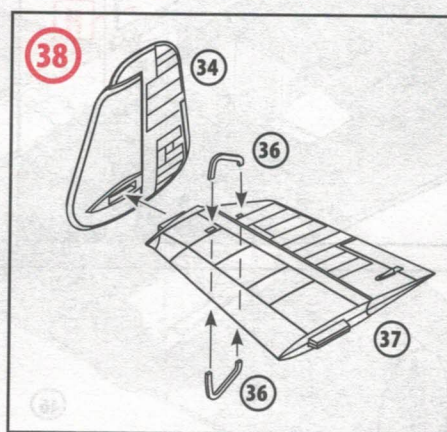
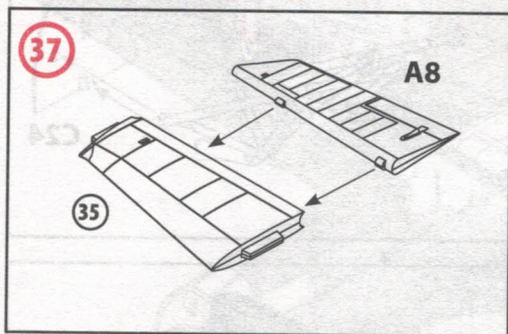
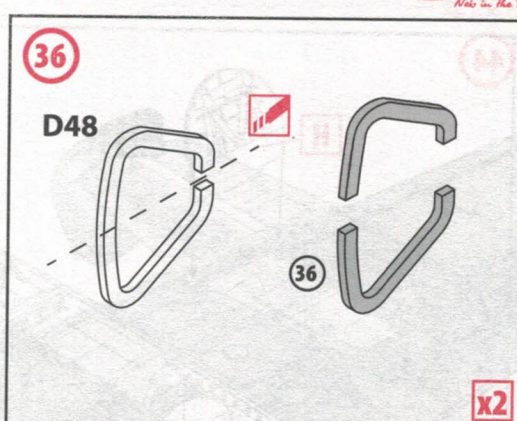
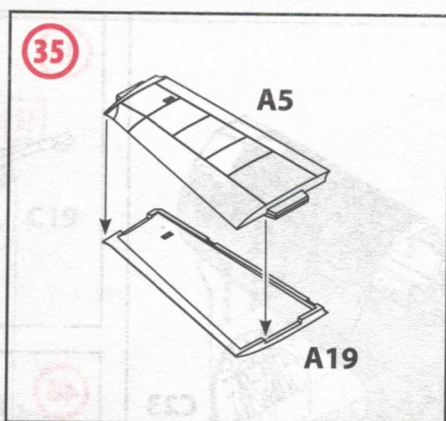
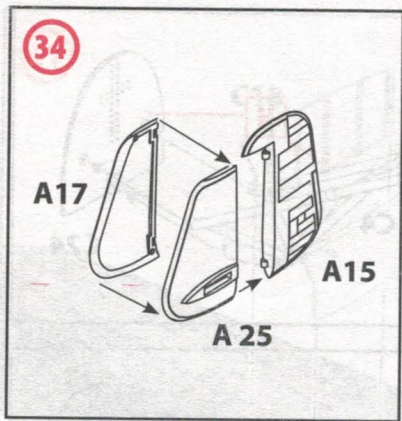

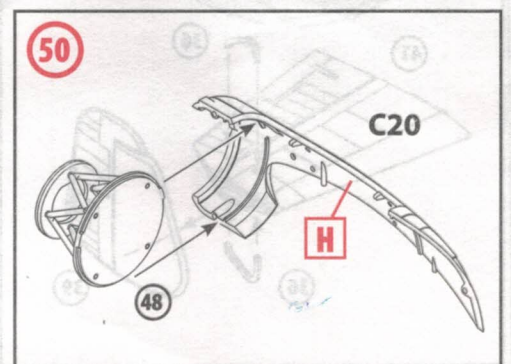
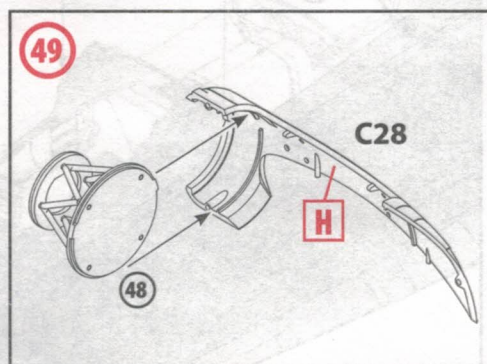
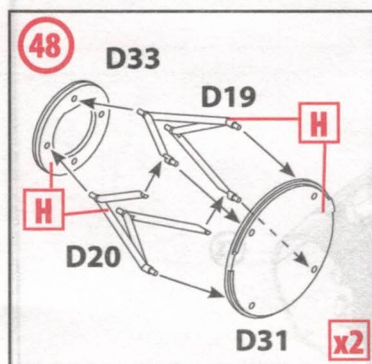
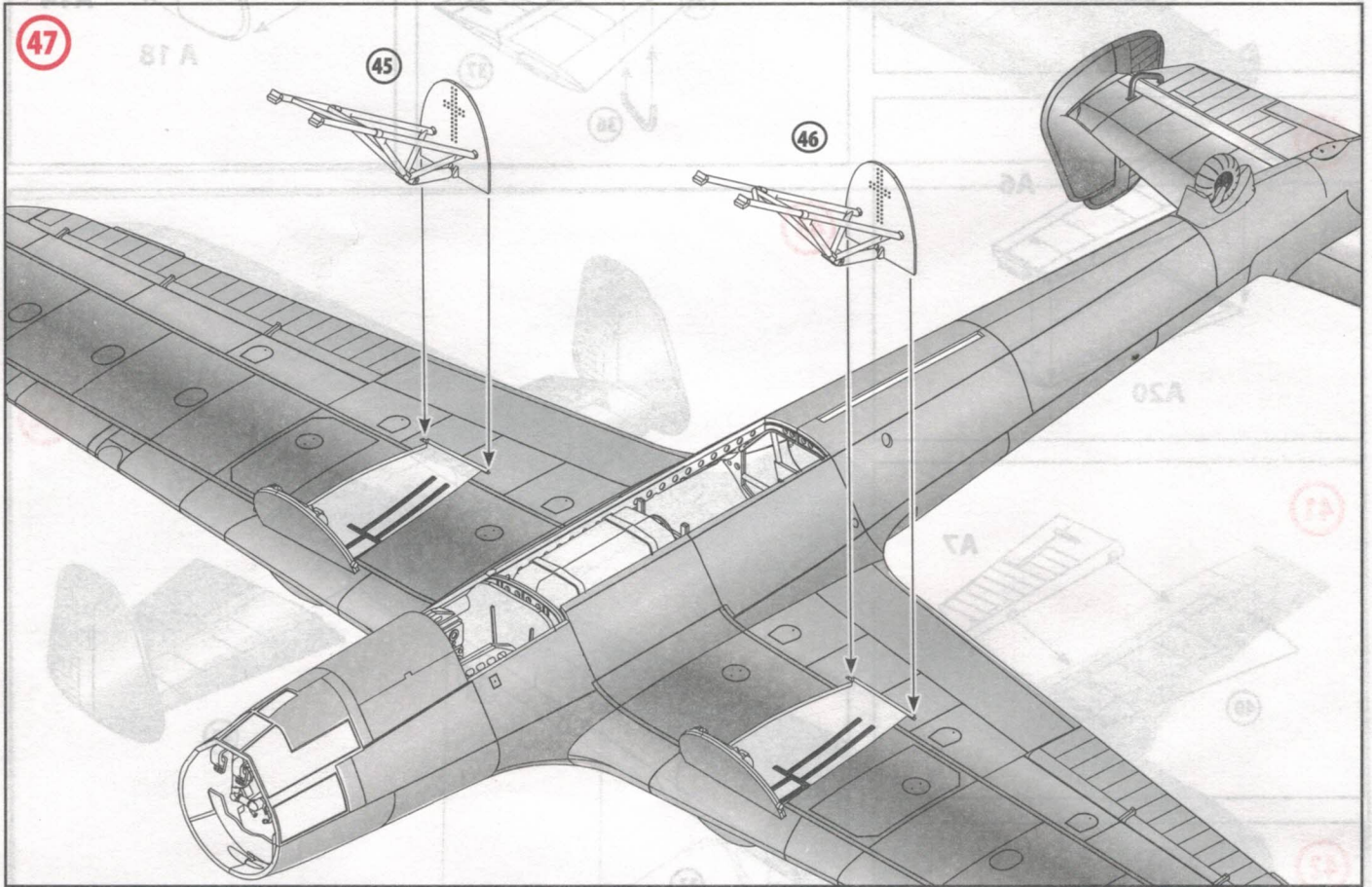
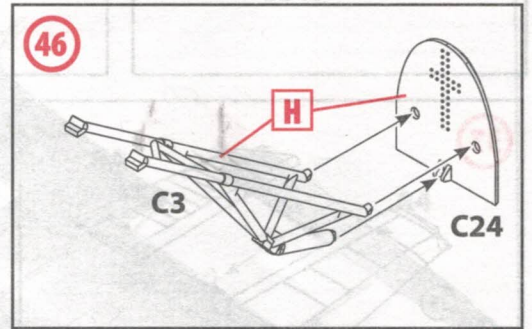
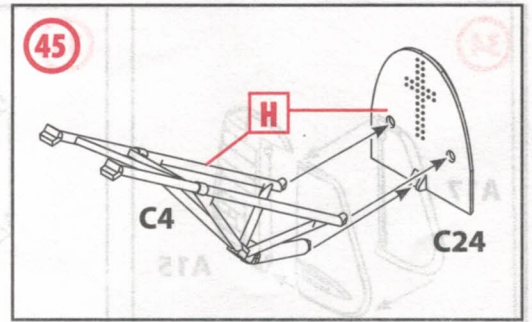
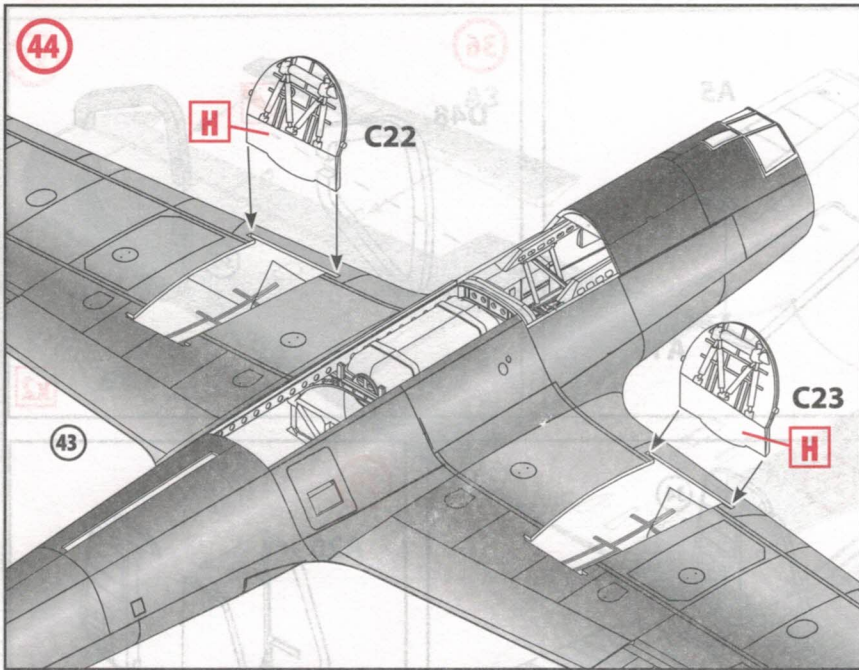

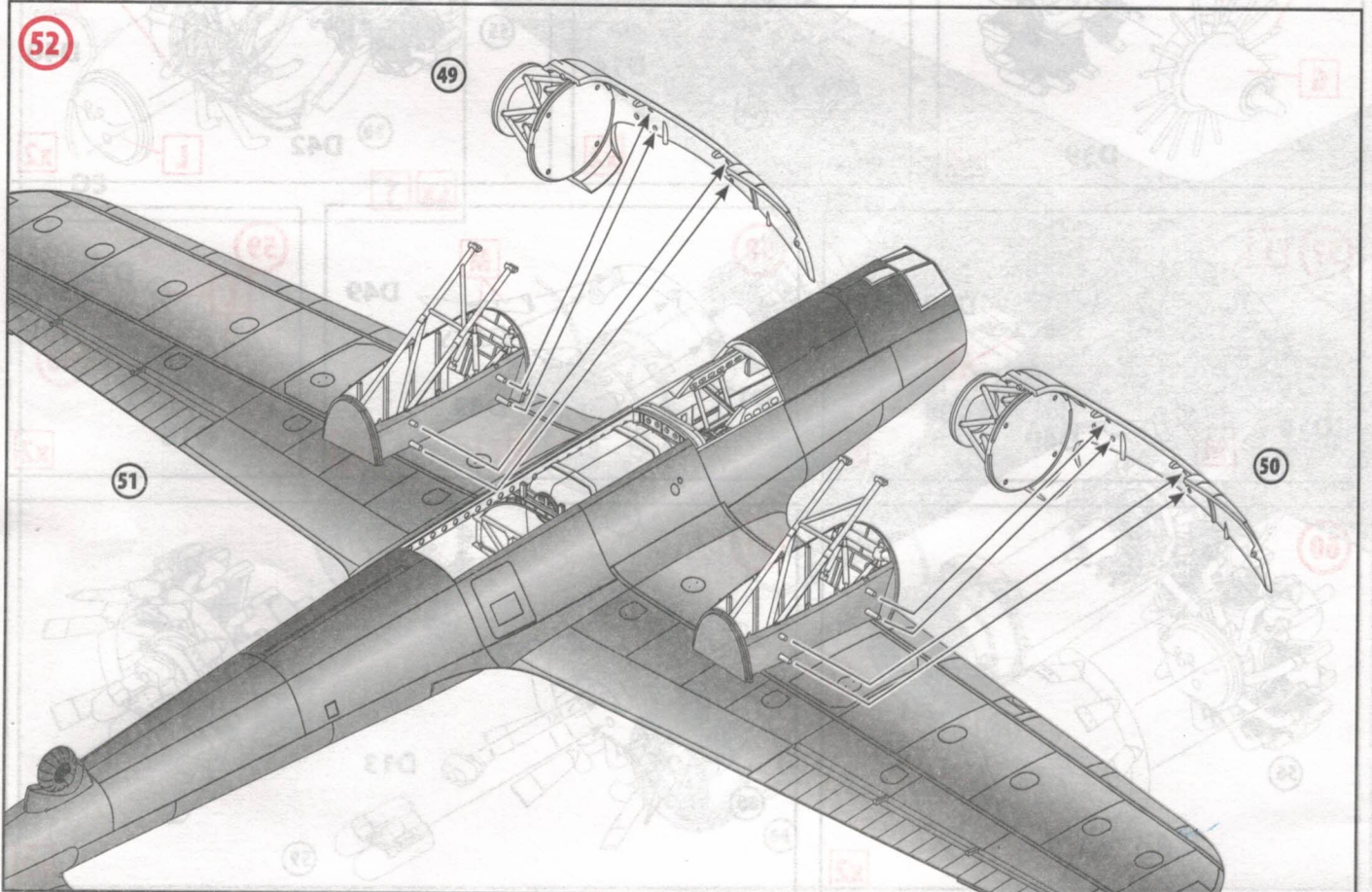
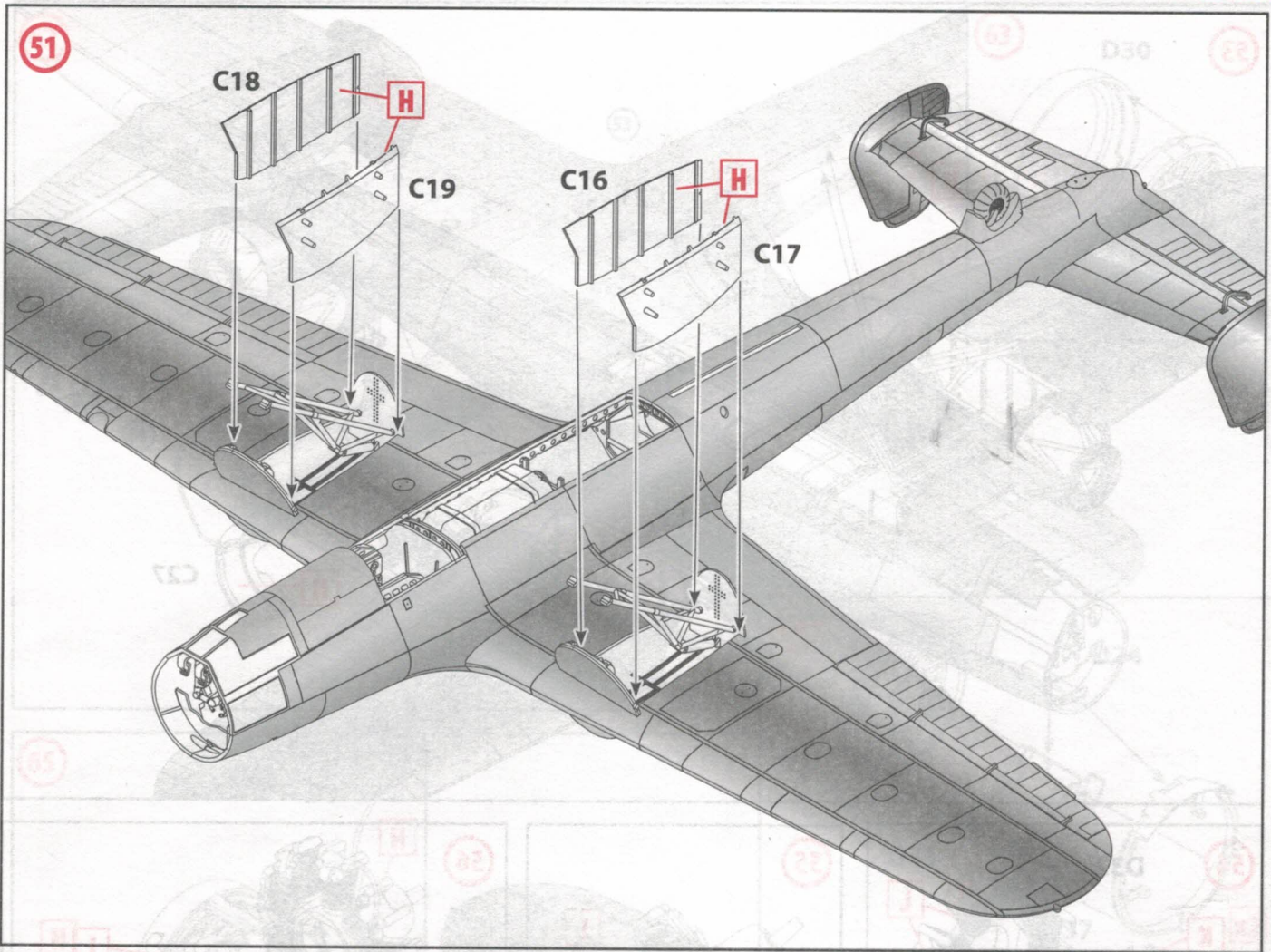

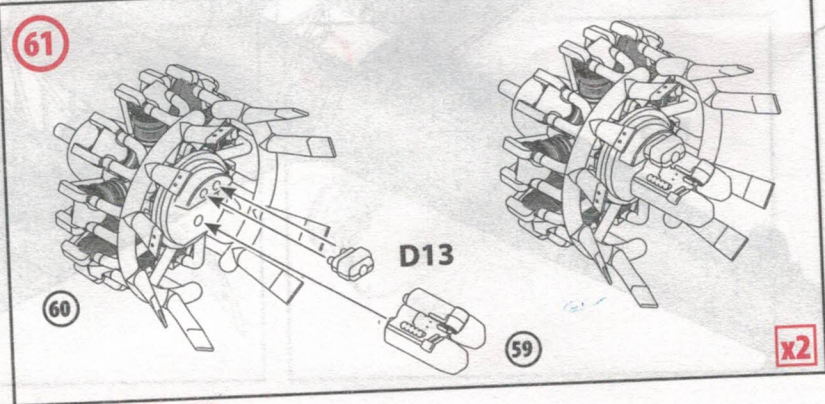
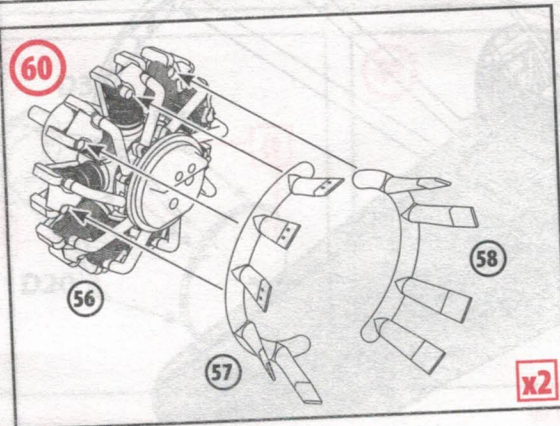
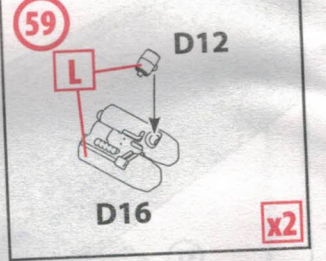
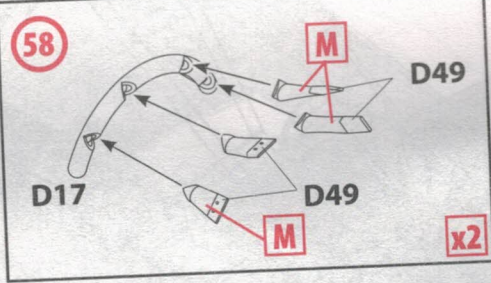
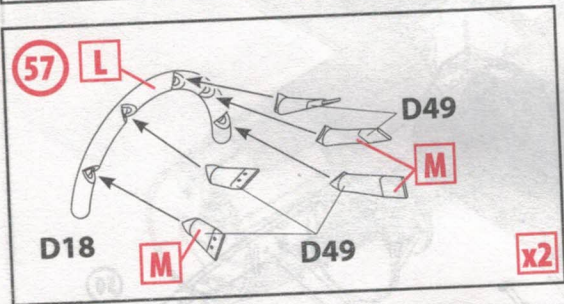
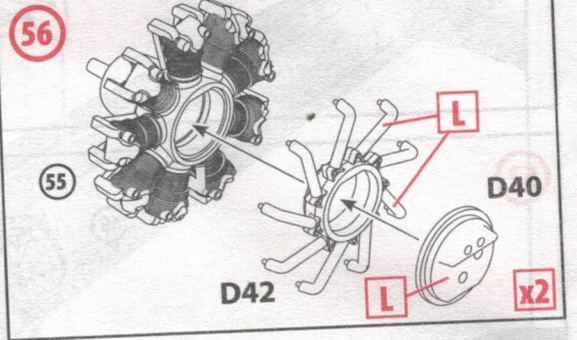
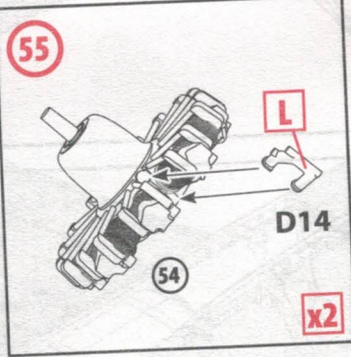
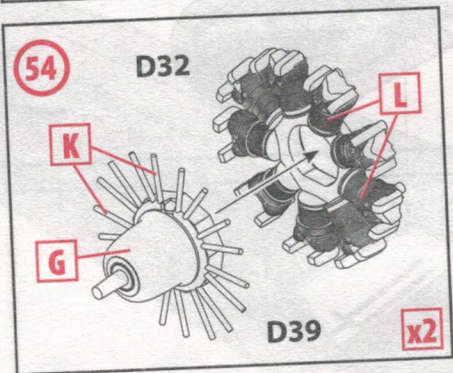
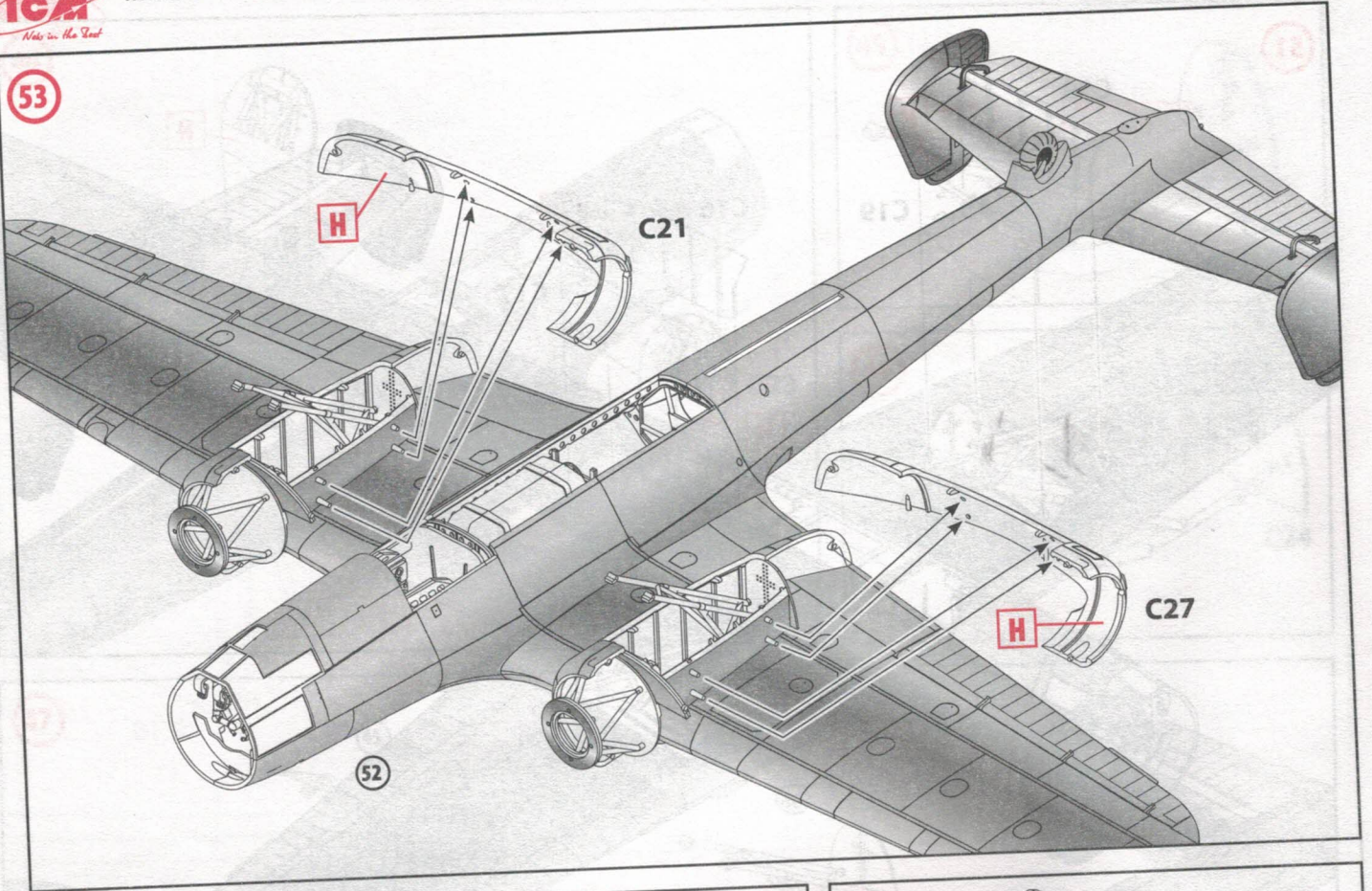

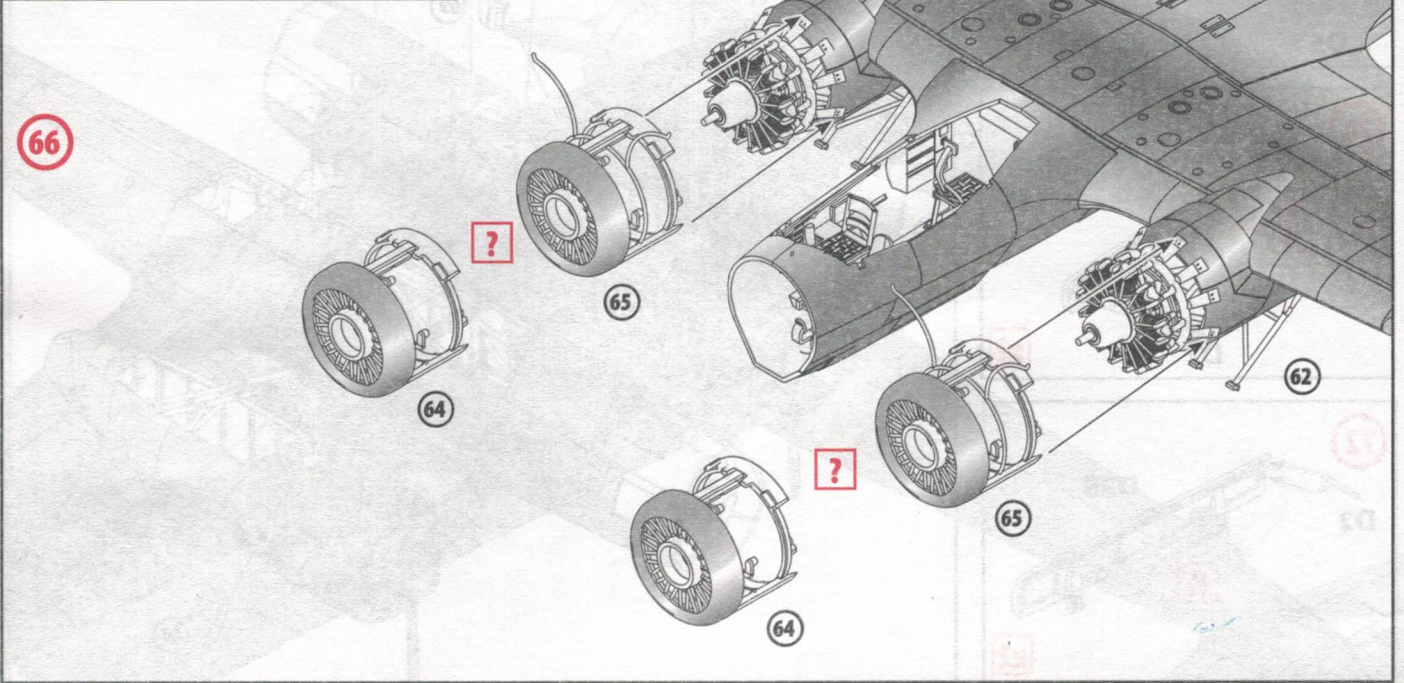
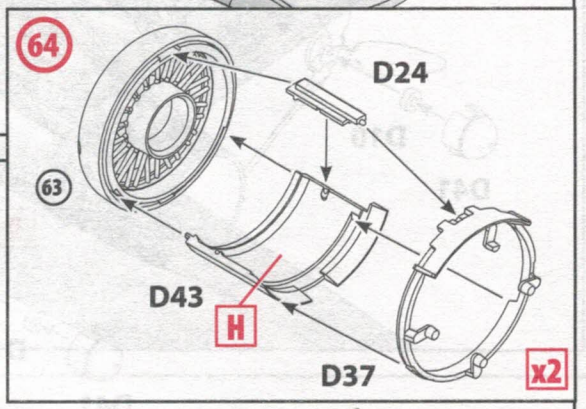
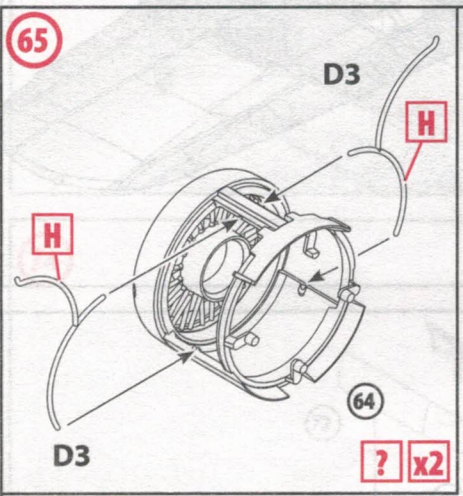
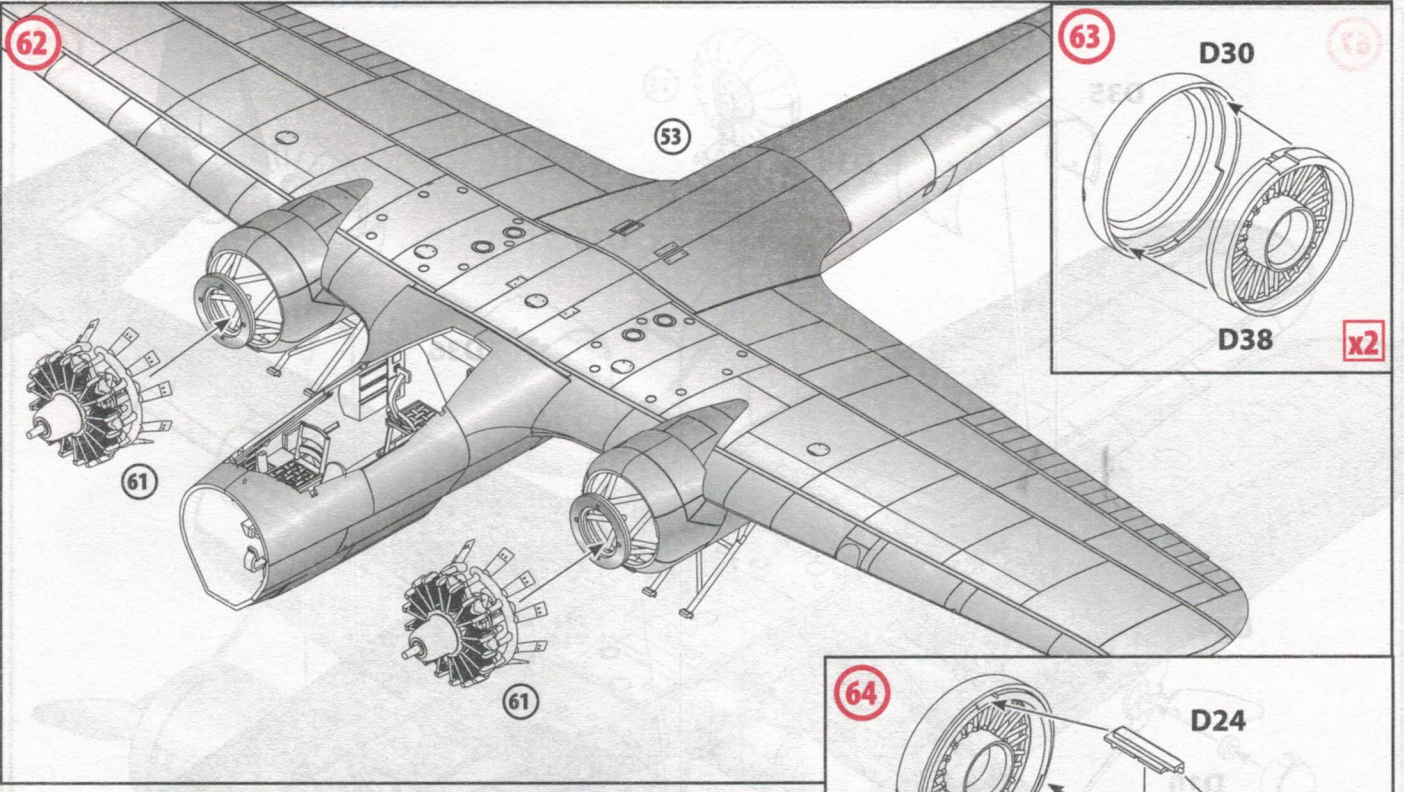

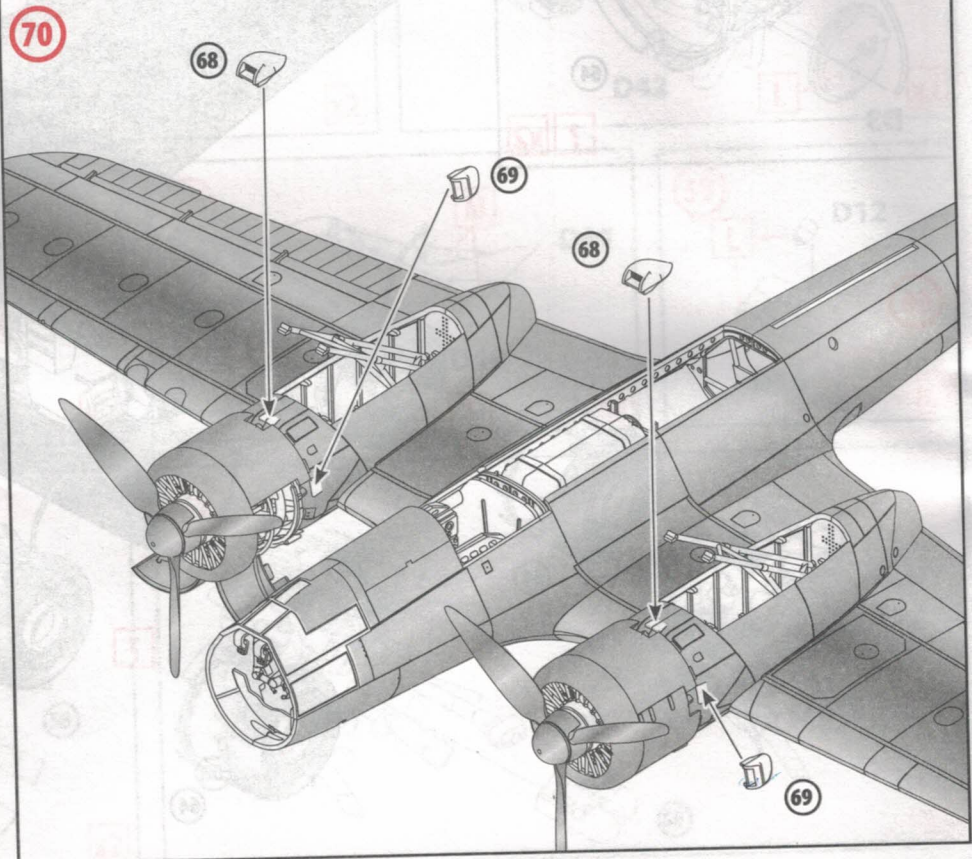
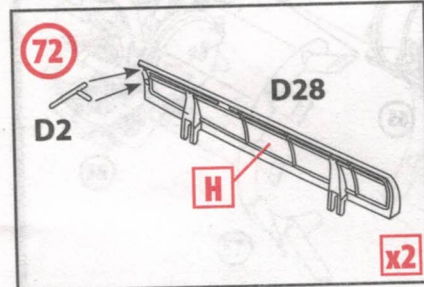
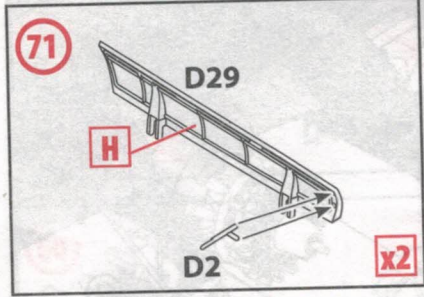
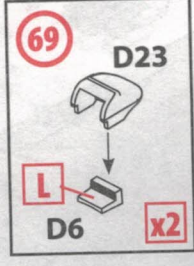
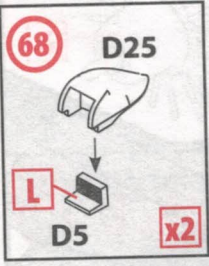
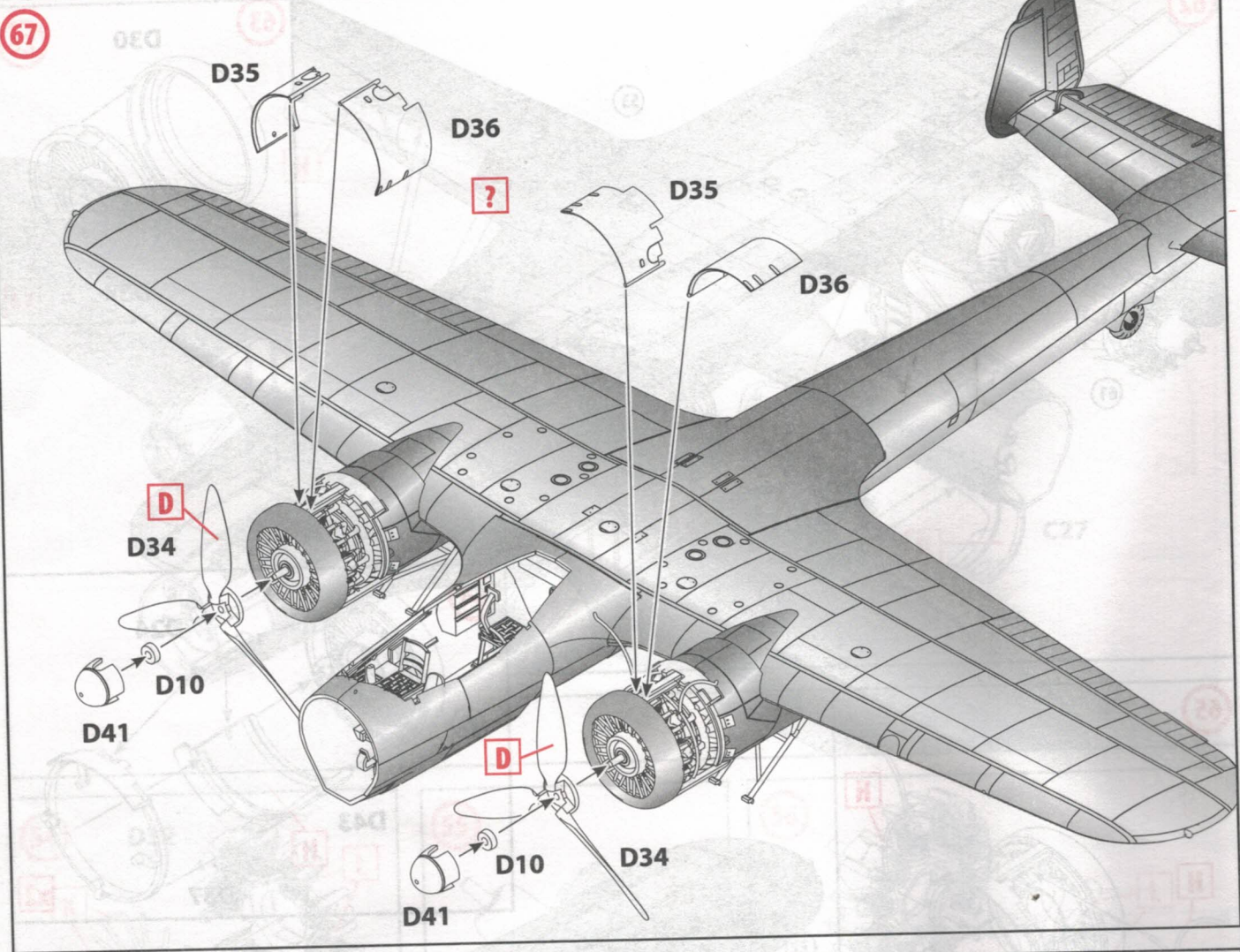

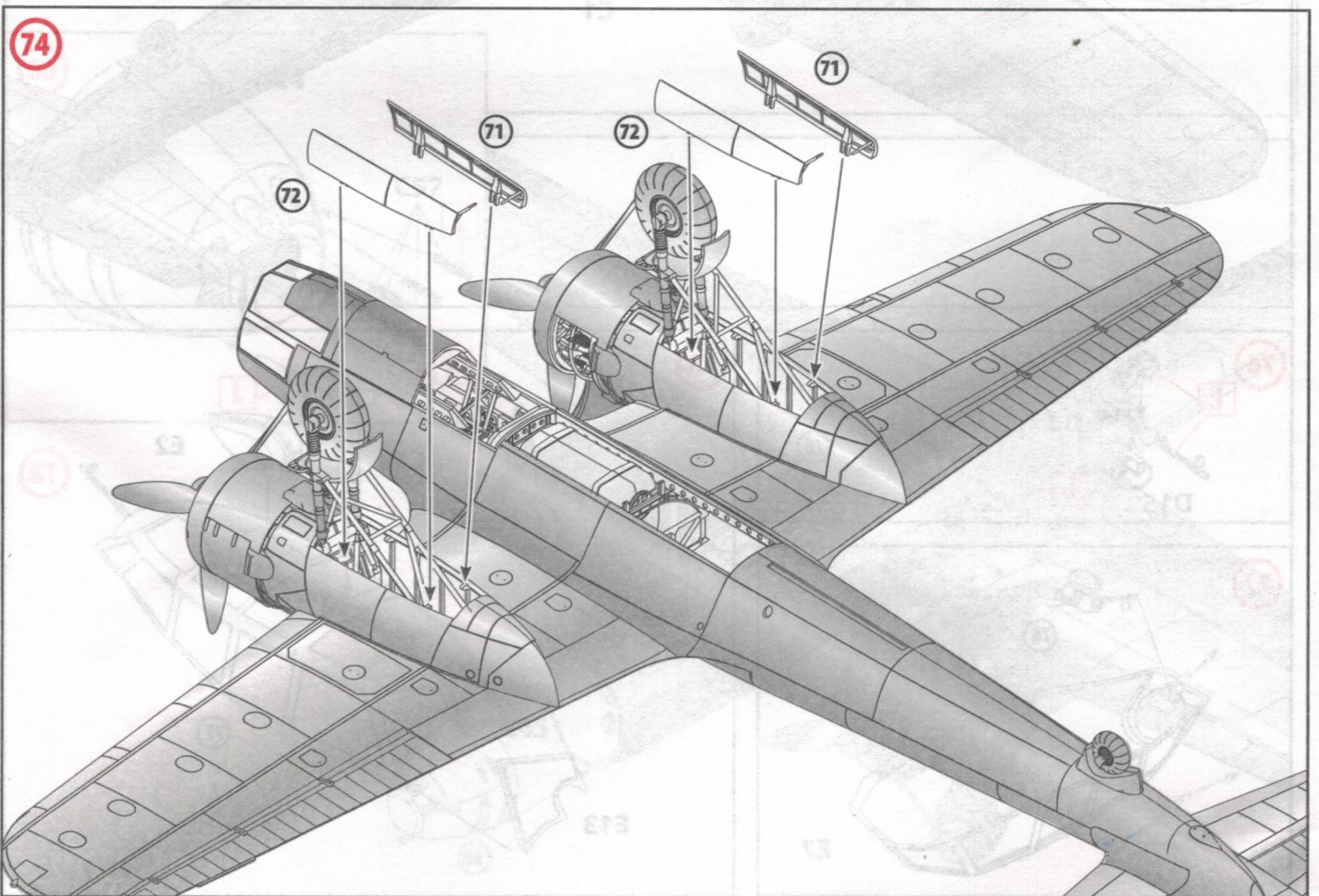
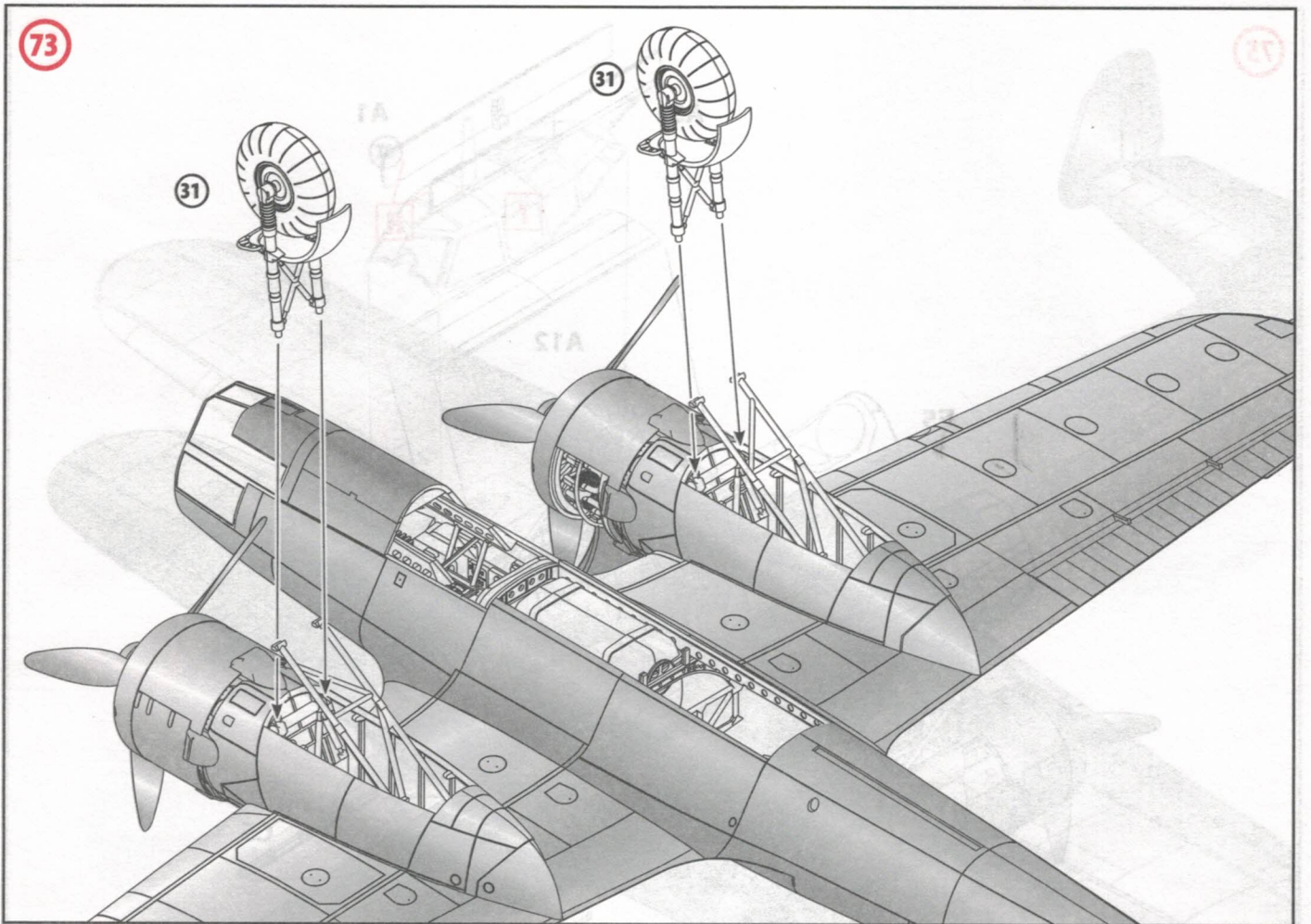

75

75

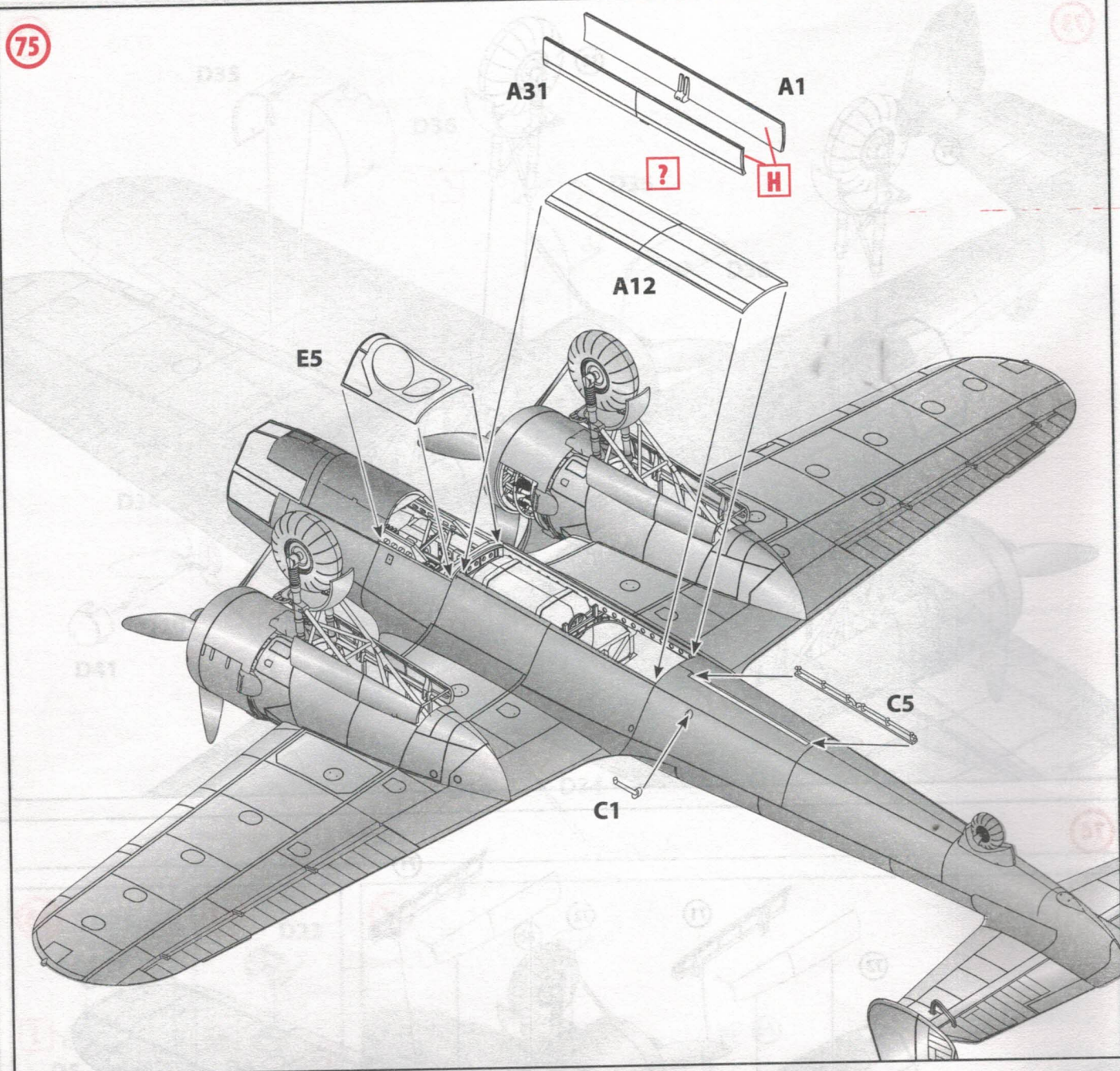

76

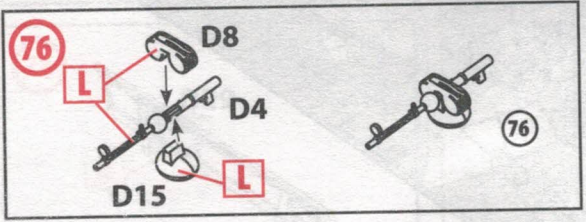

78

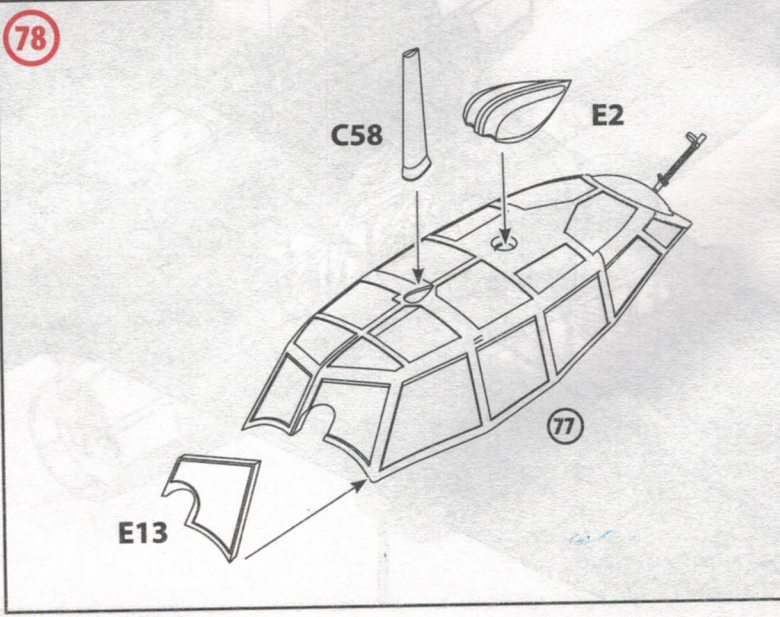

77

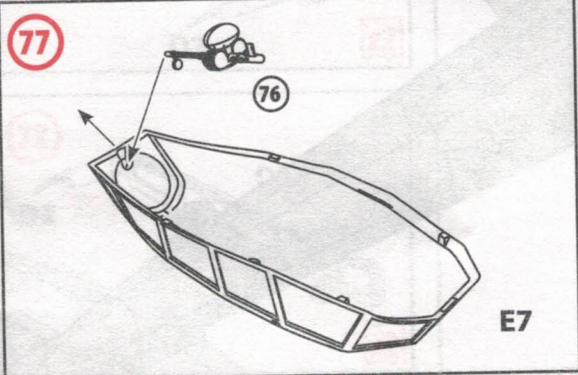



79

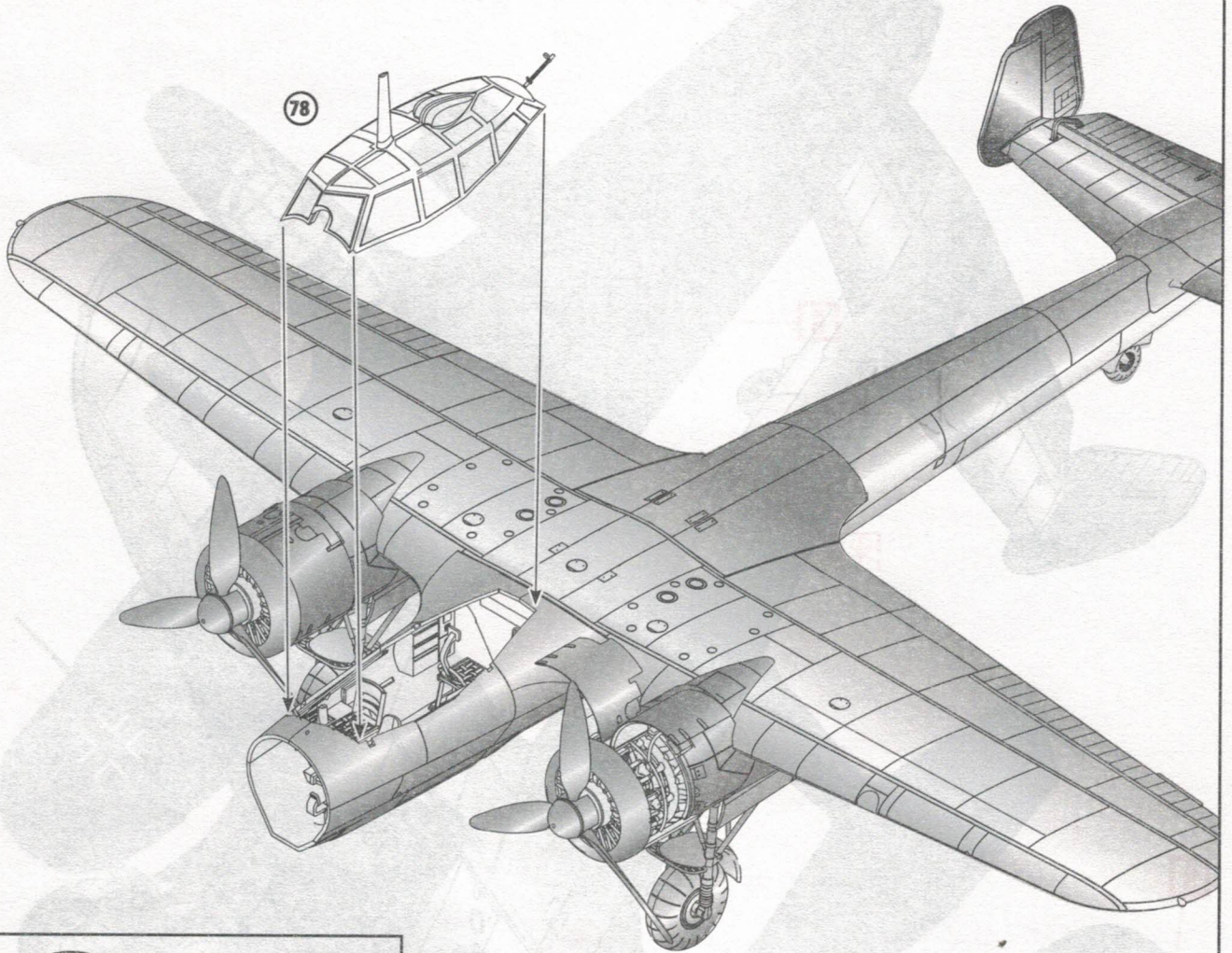

80

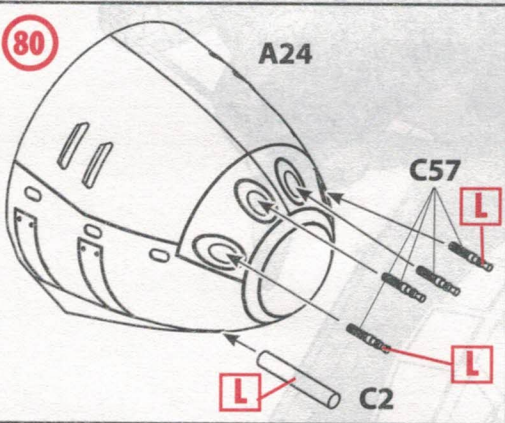

81

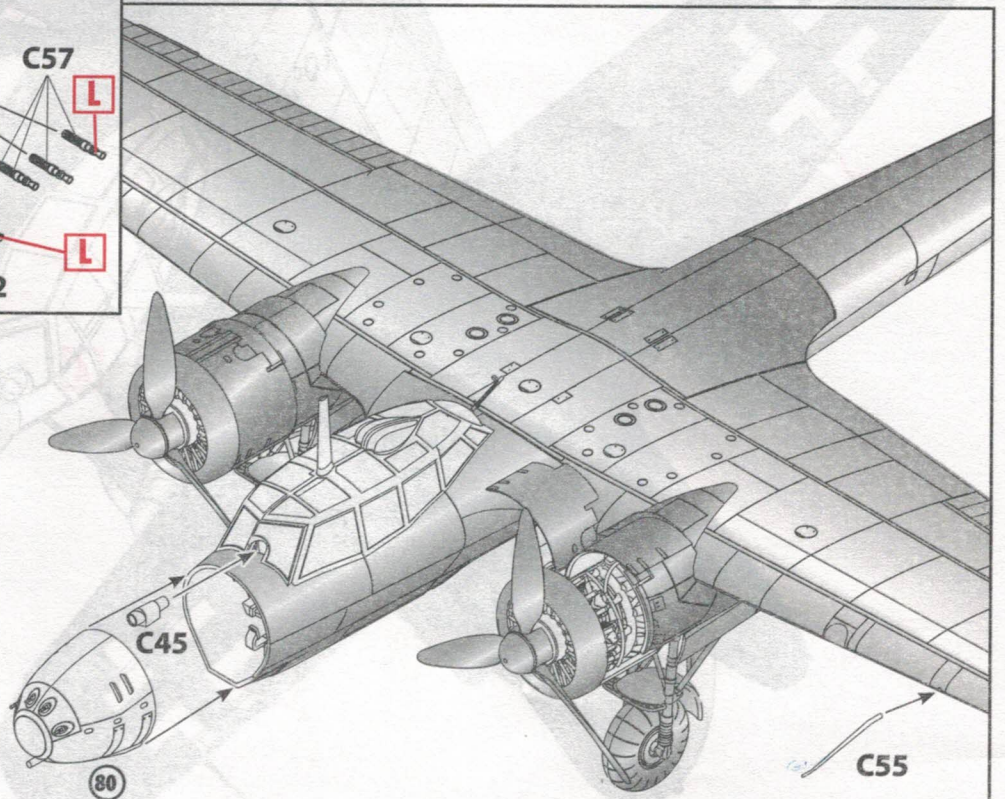

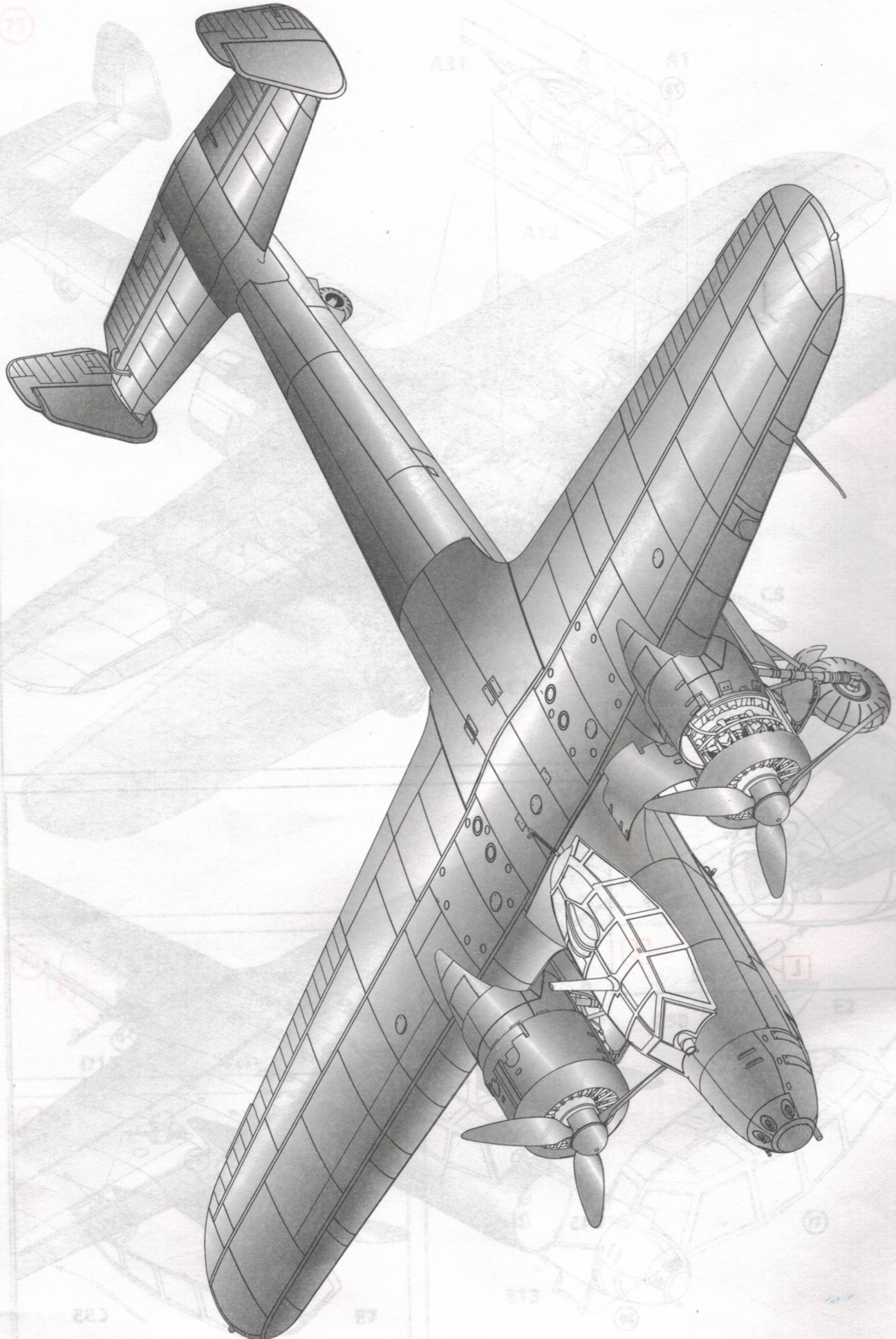

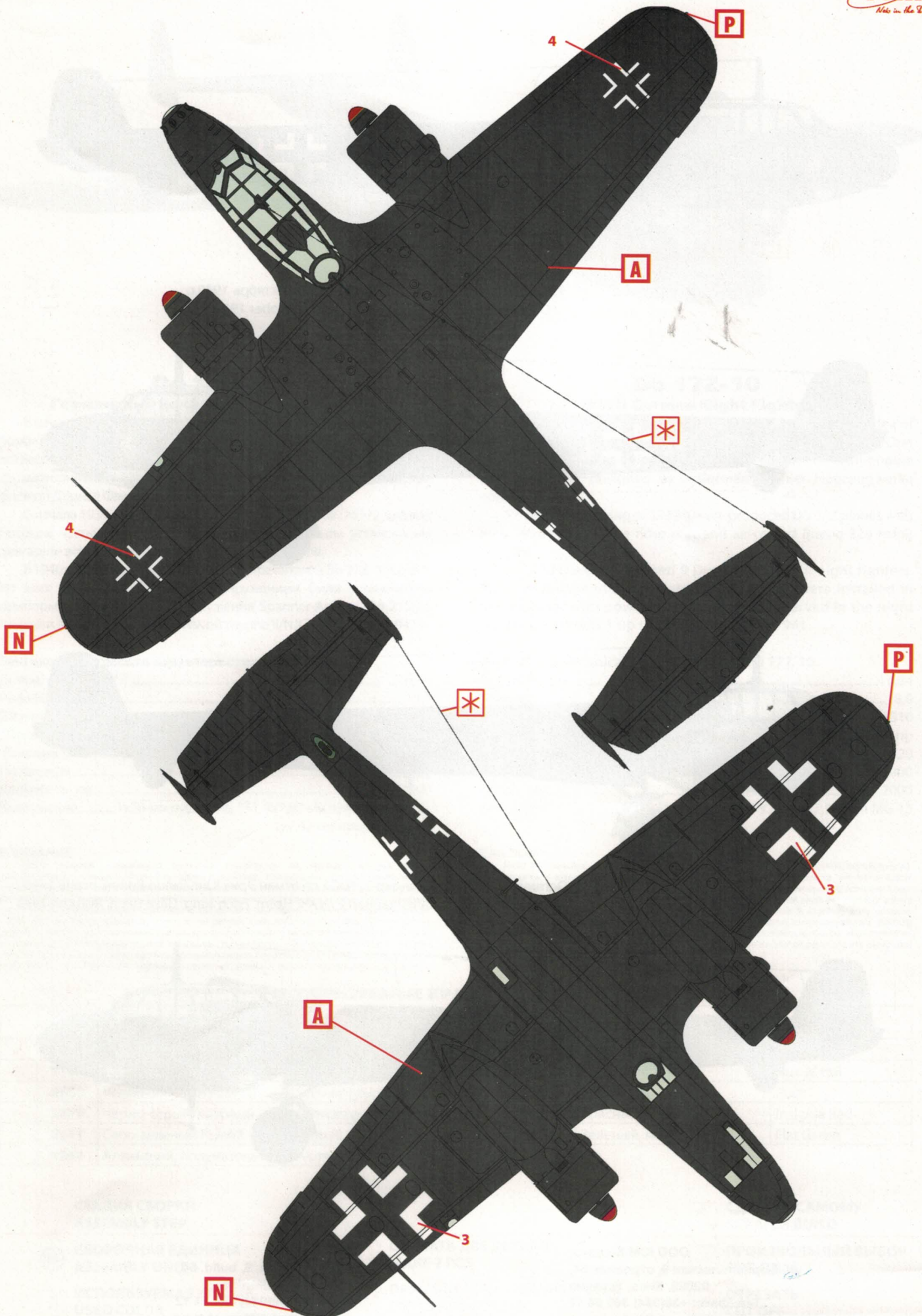

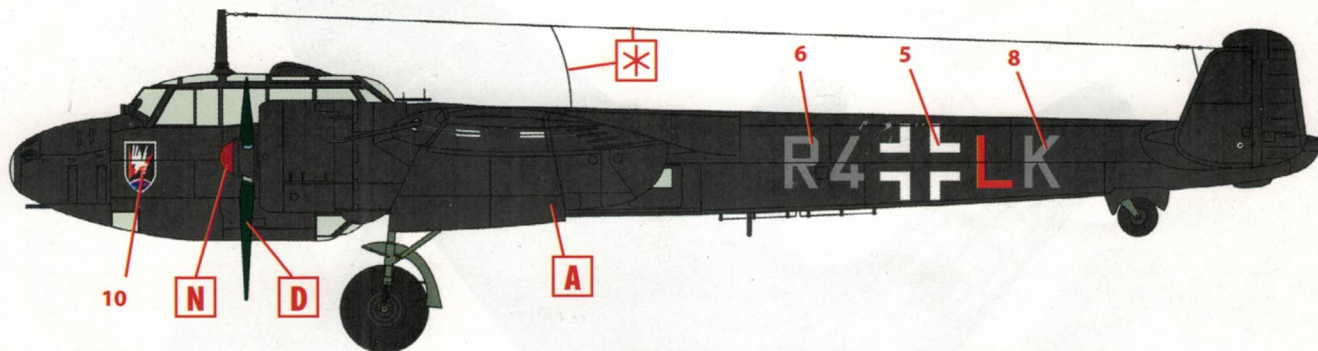

1. Dornier Do-17Z-10, I/NJG2, Гилце-Рийен, октябрь 1940 г.  
Dornier Do-17Z-10, I/NJG2, Gilze-Rijen, October 1940

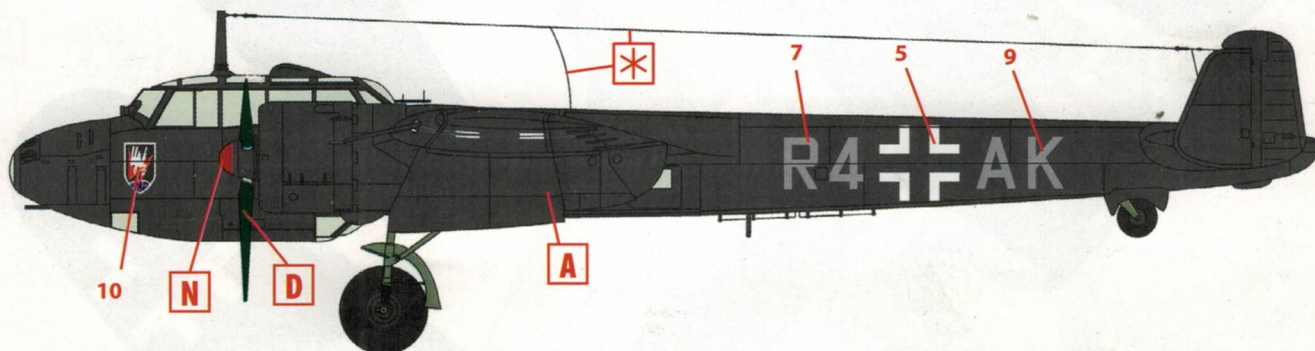
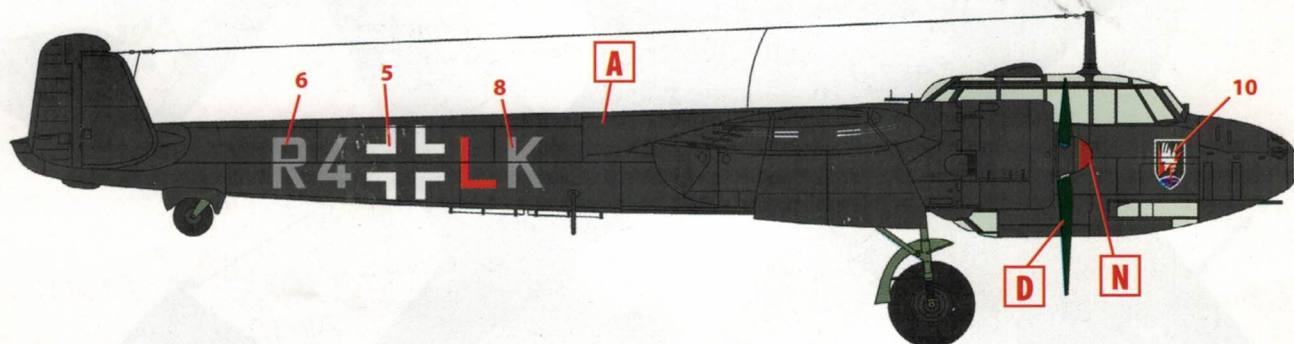

2. Dornier Do-17Z-10, командир 2./NJG2 гауптман Эрих Юнг, Гилце-Рийен, осень 1940 г.  
Dornier Do-17Z-10, Staffel-kapitan 2./NJG2 Hptm. Erich Jung, Gilze-Rijen, Autumn 1940

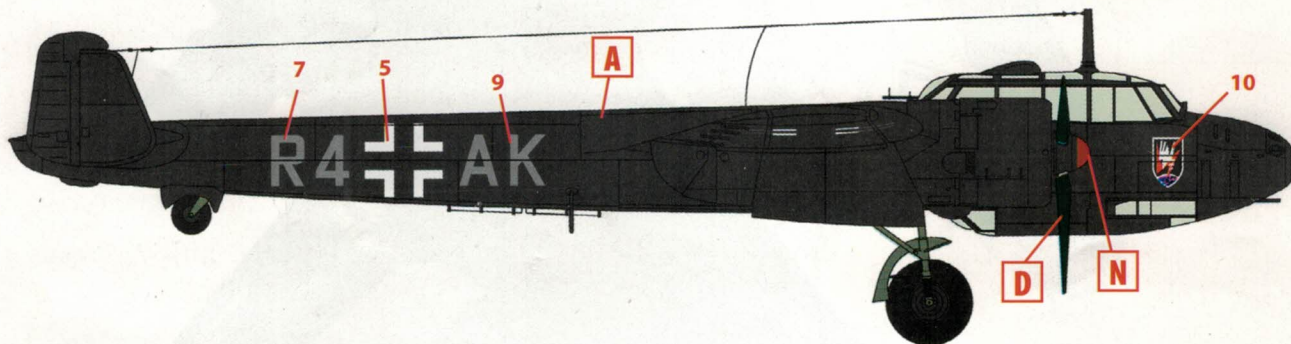

ООО ICM Холдинг  
ул. Бориспольская 9, строение 64,  
02099, Киев, Украина  
Тел./факс: +38(044) 369 54 12  
E-mail: export@icm.com.ua



[www.icm.com.ua](http://www.icm.com.ua)

ICM Holding  
Borispolskaya, 9, build. 64,  
02099, Kiev, Ukraine  
Tel./Fax: +38(044) 369 54 12  
E-mail: export@icm.com.ua