

SAAB AJ 37 Viggen 'Strike Fighter'

History

EN

The SAAB 37 Viggen was an aircraft ahead of its time. Its designers used an unorthodox construction which enabled the plane to meet all requirements which had been laid on it and in some parameters even surpass them. The Swedish Air Force ordered several various versions of the Viggen jet fighter, its basic design formed an universal platform which, using a specialized equipment, enabled the plane to be used for different roles.

The first of seven prototypes took off for its maiden flight on February 8, 1967 with E. Dalsröm at the controls.

The aircraft was powered by Volvo RM8 turbofan, a licence-built variant of Pratt & Whitney JT8D with an afterburner and thrust-reverser which, in addition to a double-delta wing design, enhanced the aircraft's performance during the take-offs and landings on short airstrips. The tailfin was designed as foldable to make it easier to store in hangars, it also helped with handling the aircraft after the landing and with hiding at the emergency airstrips. The avionics of the type was one of the best in the world in the time, Viggen was the first type to be equipped with a computer with integrated circuits.

The first version of the Viggen which saw service with the Flygvapnet was the AJ 37 strike fighter, followed consequently by the SK 37 two-seat trainer, SF 37 reconnaissance version with cameras in redesigned nose section and anti-shipping SH 37 with different avionics and equipped with anti-shipping weapons. Ten years after the first version of the SAAB had entered service, a second generation of the Viggen came into being, which was the JA 37 fighter version. More modern avionics was used and also a more powerful engine in a slightly longer fuselage. The earlier versions became to be equipped with the modernised avionics too and this way the AJS 37, respectively ASFS and ASHS 37 versions were created. Some of the two seat airframes were converted to the SK 37 E electronic warfare trainers.

The last of the Viggens were phased out in 2007. Mainly for political reasons, no Viggen has ever been exported to another countries, although India, Japan and Scandinavian countries showed some interest in the type.

Length: 16,30 m, Wingspan: 10,60 m, Max. speed: 2145 km/h, Standard Range: 1000 km/ Max. Range: 2000 km, Ceiling: 18 300 m, Rate of Climb: 100 m/s

Historie

CZ

SAAB 37 Viggen je letoun, který předběhl svou dobu. Neortodoxní řešení, zvolená jeho konstruktéry, nejen umožnily Viggenu splnit požadavky na něj kladené, ale v některých parametrech je předčít. Švédské letectvo objednalo Viggen v několika verzích, s tím, že základní provedení letounu tvořilo univerzální platformu, která doplněná o speciální vybavení umožňovala použití v několika rolích.

První ze sedmi stavěných prototypů vzlétl 8. února 1967, řízen pilotem E. Dalsrömem. Pohon zajišťoval motor Volvo RM8, licenční civilní motor Pratt & Whitney JT8D doplněný o přídavné spalování a obraceče tahu. To, stejně jako koncepce dvojitých delta křídel přispívalo k vynikajícím vlastnostem Viggenu při startech a přistáních na malých přistávacích plochách. Pro lepší manipulaci s letouny po přistání umístění do hangárů či jejich lepšímu zamaskování při operacích z nestandardních ploch dostal Viggen sklopnou svislou ocasní plochu. Elektronické vybavení bylo ve své době jedno z nejlepších na světě, Viggen byl první stroj se zabudovaným počítačem s integrovanými obvody. Do výzbroje švédského letectva byla jako první zařazena verze AJ 37 Viggen, kterou postupně následovaly verze SK 37 - dvoumístný cvičný stíhací letoun, SF 37 - průzkumná verze s fotografickými přístroji v upravené přídi, SH 37 - protilodní verze s odlišným elektronickým vybavením a protilodní výzbrojí. Po cca deseti letech od zařazení první verze byla vyrobena druhá generace Viggenu, stíhací verze JA 37. Ta dostala modernizované elektronické vybavení a silnější motor v nepatrně prodlouženém trupu. Modernější elektronické vybavení dostaly i starší verze, přestavbou vznikaly stroje AJS 37, případně ASFS a ASHS 37. Část dvoumístných cvičných strojů byla přestavěna na verzi pro výcvik elektronického boje SK 37E. Švédské letectvo vyřadilo poslední Viggenu v roce 2007. Export Viggenu se nezdařil, většinou z politických důvodů. Mezi největší zájemce patřila např. Indie, ale zájem projevovaly i skandinávské země či Japonsko.

délka: 16,30 m, rozpětí: 10,60 m, max. rychlost: 2145 km/h, dolet standardní: 1000 km/maximální: 2000 km, dostup: 18 300 m, rychlost stoupání: 100 m/s

PLASTIC PARTS

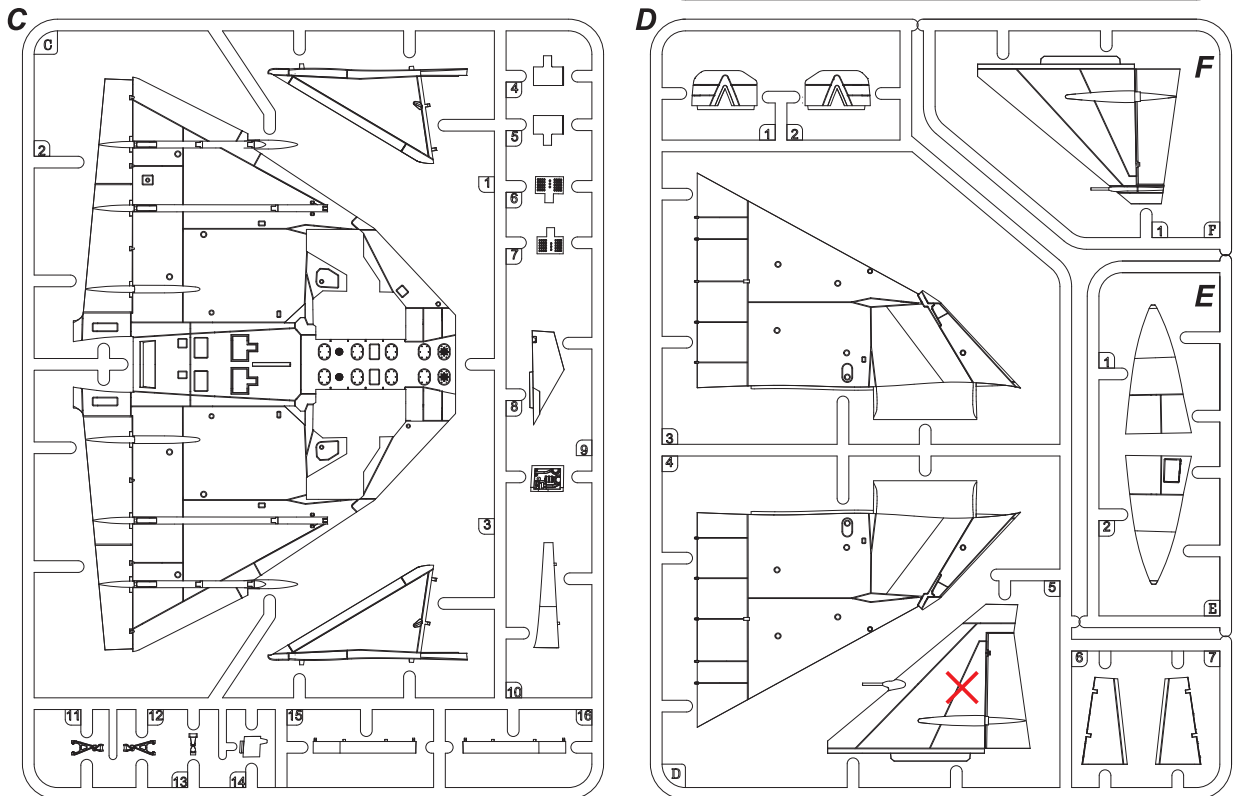
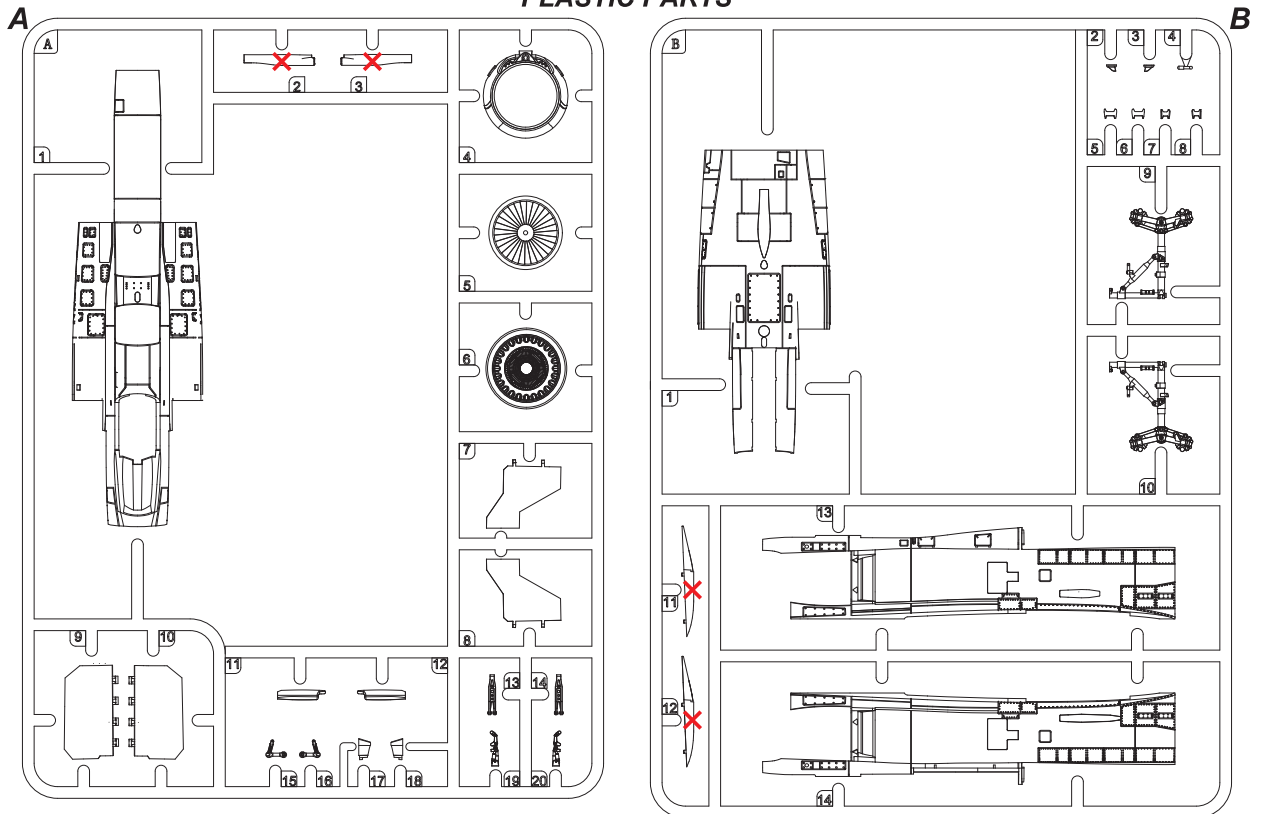

SYMBOLS

? MOŽNOST VOLBY
OPTIONAL
NACH BELIEBEN
OPTION

🔴 POUŽIT KYANOAKRYLÁTOVÉ LEPIDLO
INSTANT CYANOACRYLATE GLUE
ZYANOAKRYLATKLEBER
COLLE CYANOACRYLAT

↶ OHNOUT
BEND
BIEGEN
COURBER

👉 ZHOTOVIT NOVÉ
SCRATCH BUILD
FERTIGSTELLEN
ACHEVER

✂ REZAT/VRTAT
CUT OFF/DRILL
ENTFERNEN
DETACHER

A
GSI
colour code

🎨 NATŘÍT
COLOUR
FARBEN
PEINDRE

K

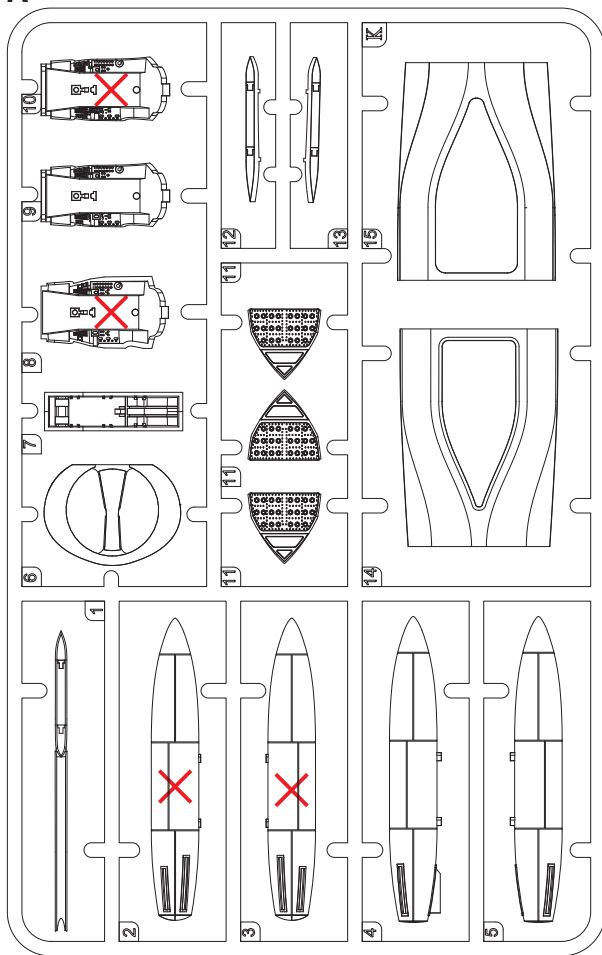

J

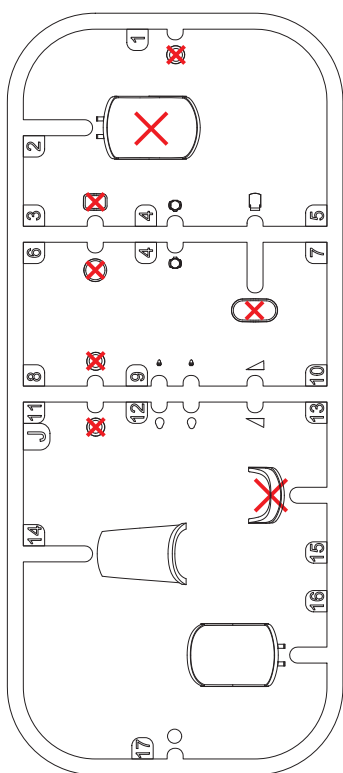
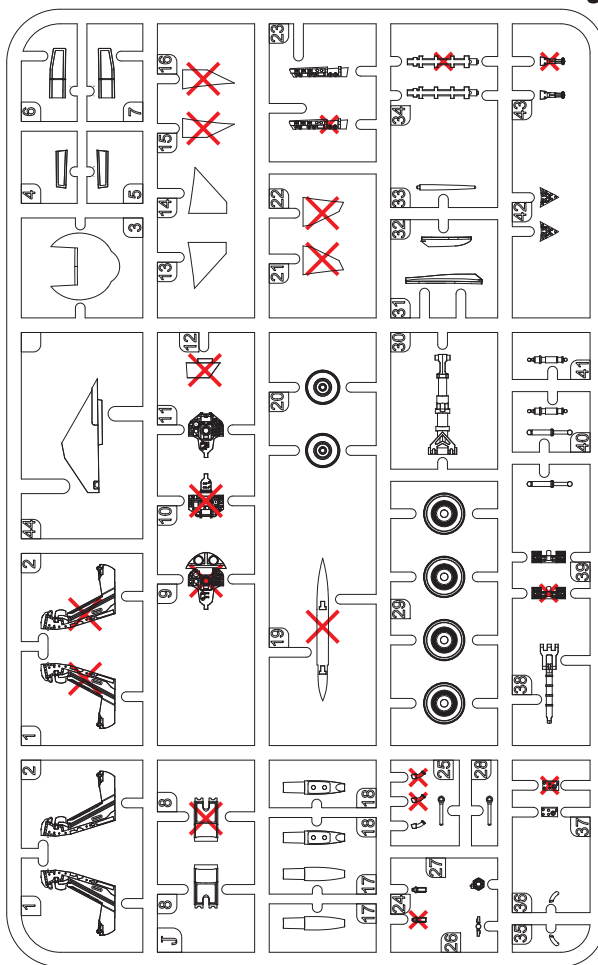

J
(Clear
Parts)

X
Do Not Use

Barvy GUNZE/ GUNZE Colour No.

| | | | | | |
|---|-------------------------|-----------|---|--------------------------|------------|
| A | Černá/ Black | H12/ C33 | J | Tm. zelená/ Dark Green | H309/ C309 |
| B | Černá pneu./ Tire Black | H77/ C137 | K | Sv. zelená / Light Green | H58/ C27 |
| C | Ocel/ Steel | H18/ C28 | L | Sv. hnědá/ Tan | H310/ C310 |
| D | Hliník/ Aluminium | MC218 | M | Červeno hnědá/ Red Brown | H47/ C41 |
| E | Opálený kov/ Burnt Iron | H76/ C61 | N | Červená/ Red | H3/ C3 |
| F | Zelená/ Bright Green | H26/ C66 | O | Žlutá/ Yellow | H4/ C4 |
| G | Sv. zelená/ Light Green | H319 | P | Čirá modrá/ Clear Blue | H93/ C50 |
| H | Sv. šedá/ Light Grey | H338 | Q | Čirá červená/ Clear Red | H90/ C47 |
| I | Šedá/ Grey | H308 | | | |

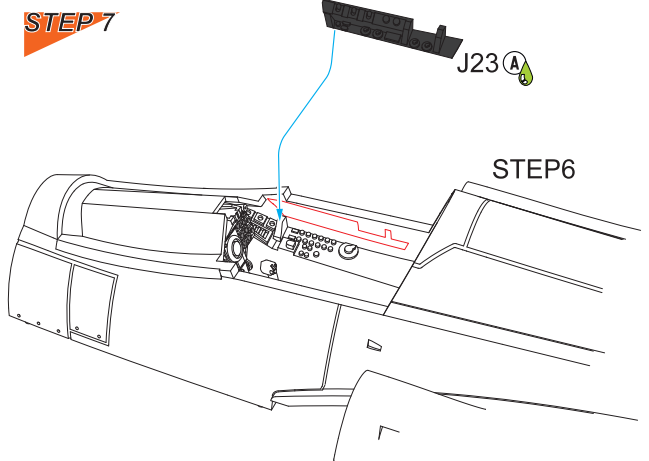
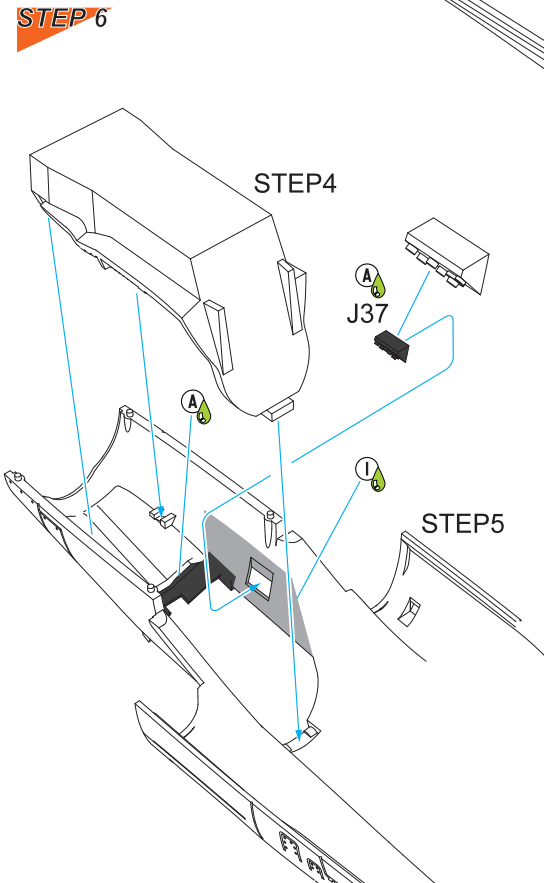
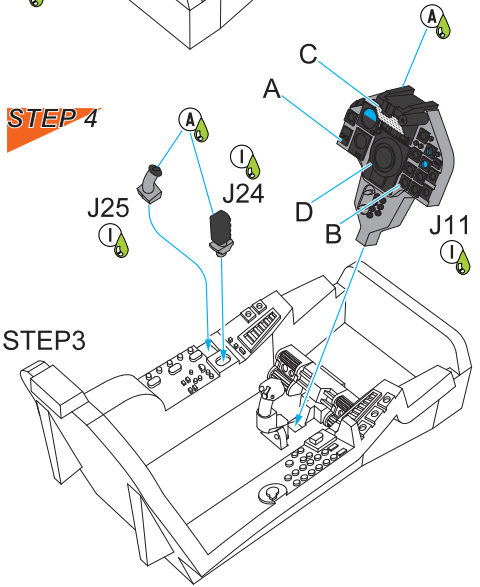
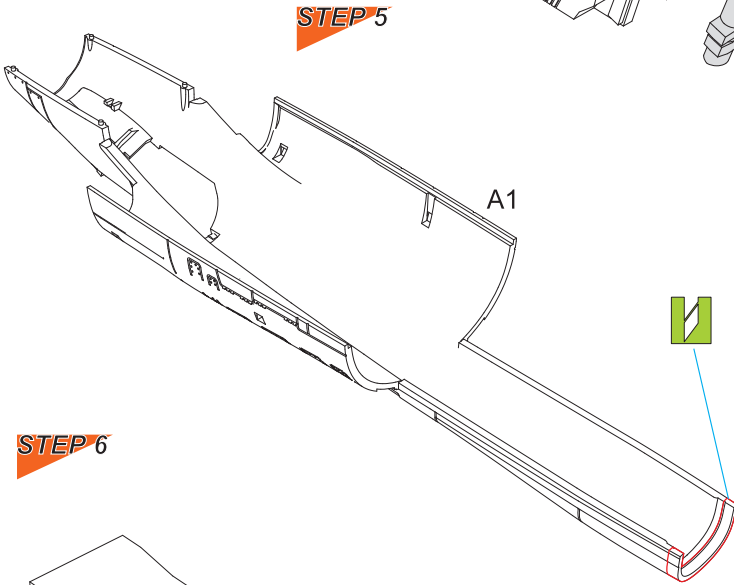
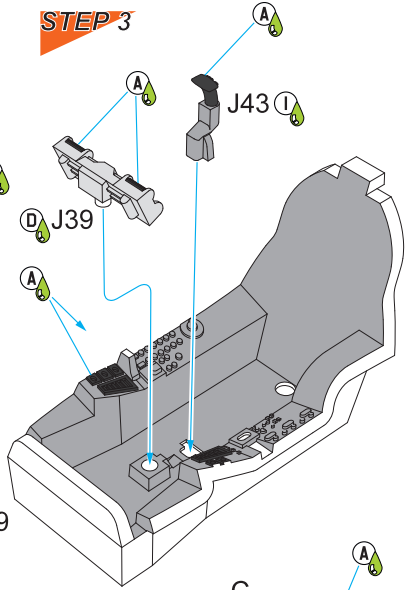
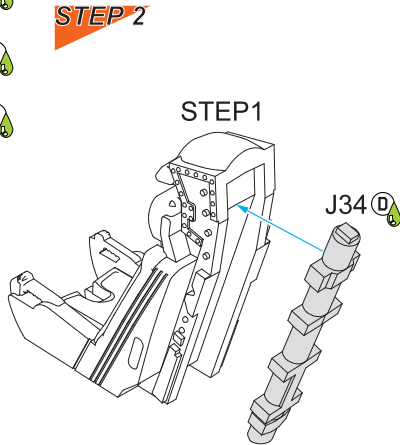
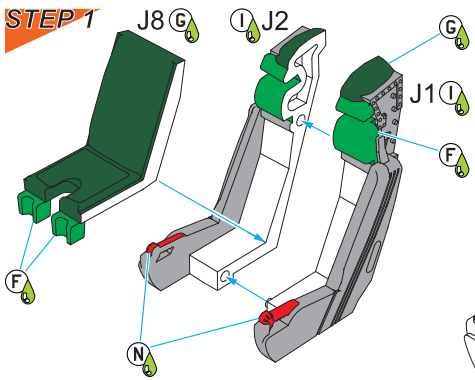

STEP 8

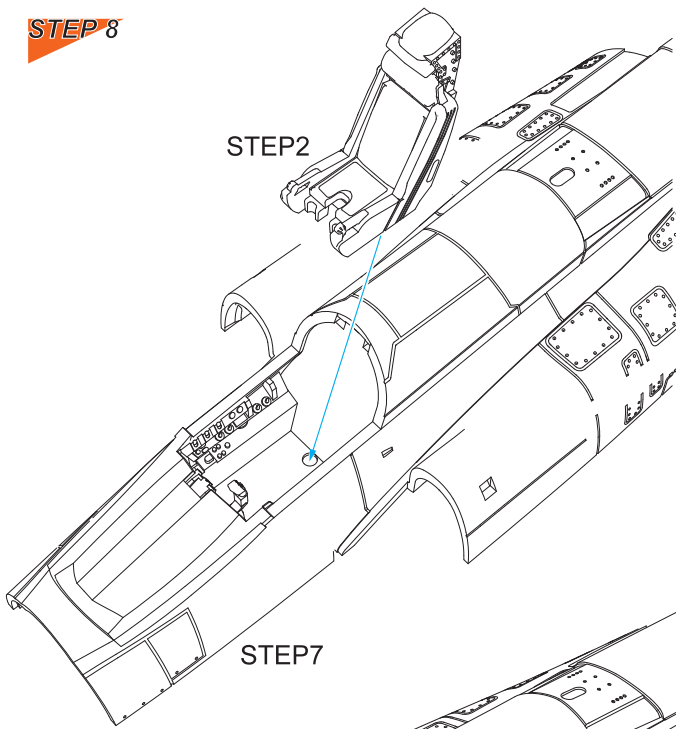

STEP 9

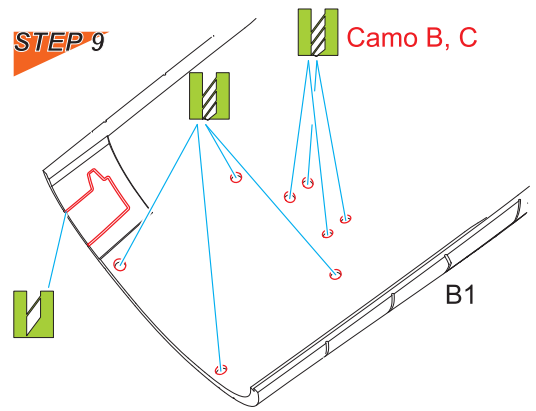

STEP 12

STEP 8

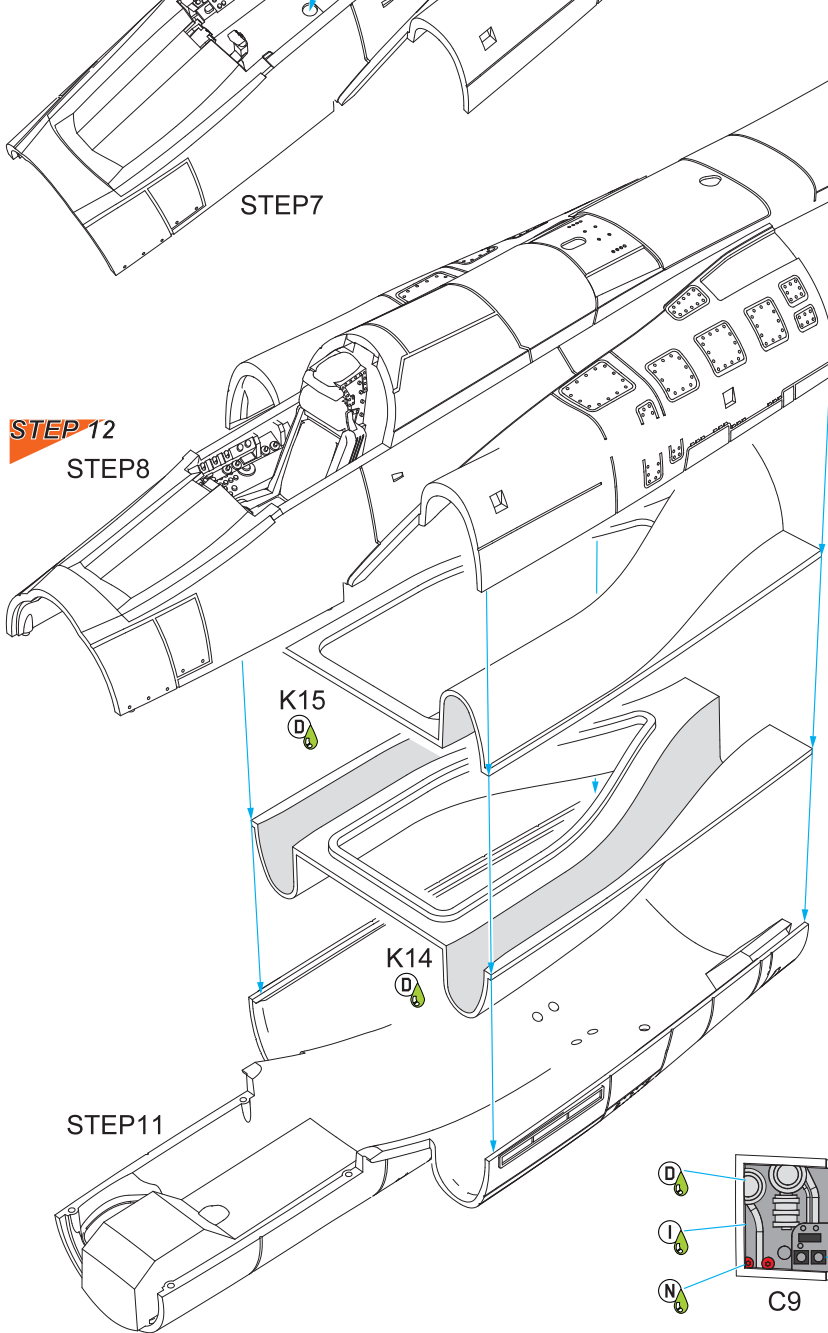

STEP 10

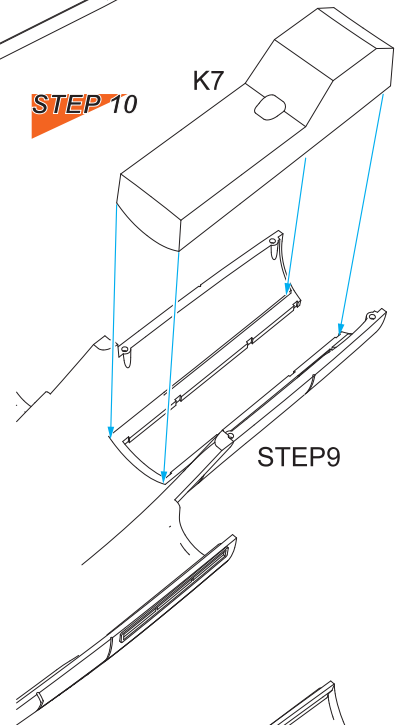

STEP 11

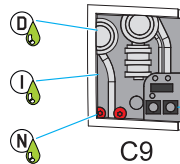
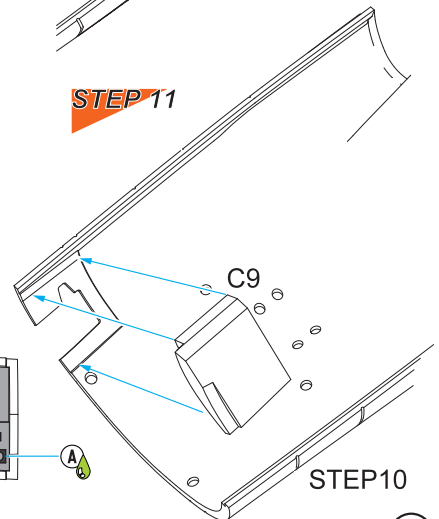

STEP 13

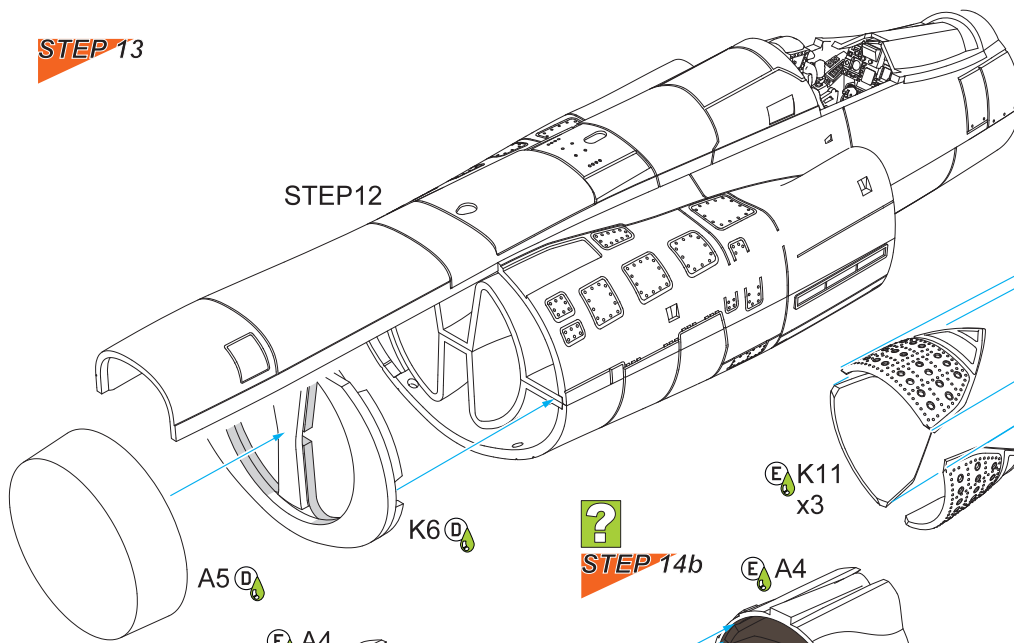

STEP 14a

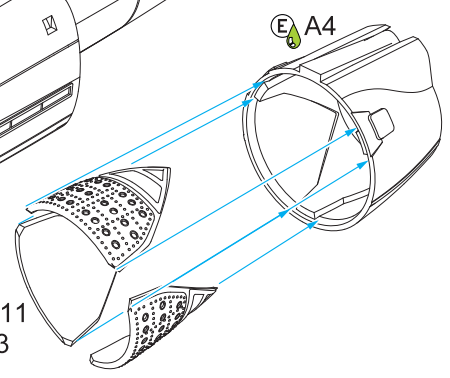

STEP 14b

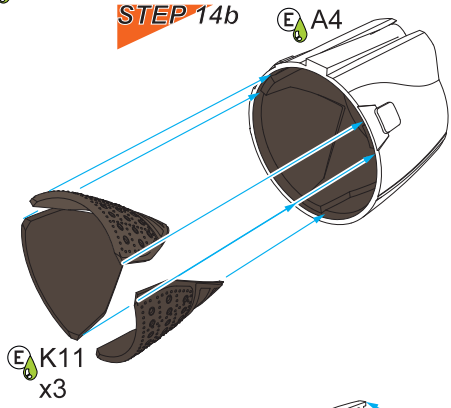

STEP 14c

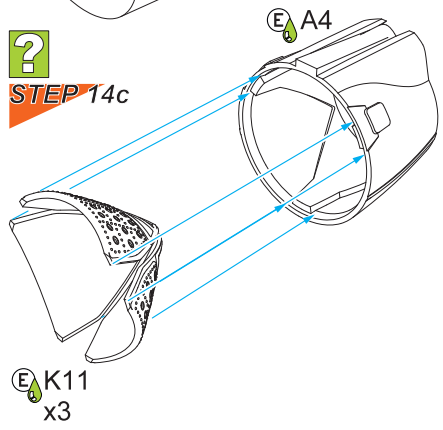

STEP 15

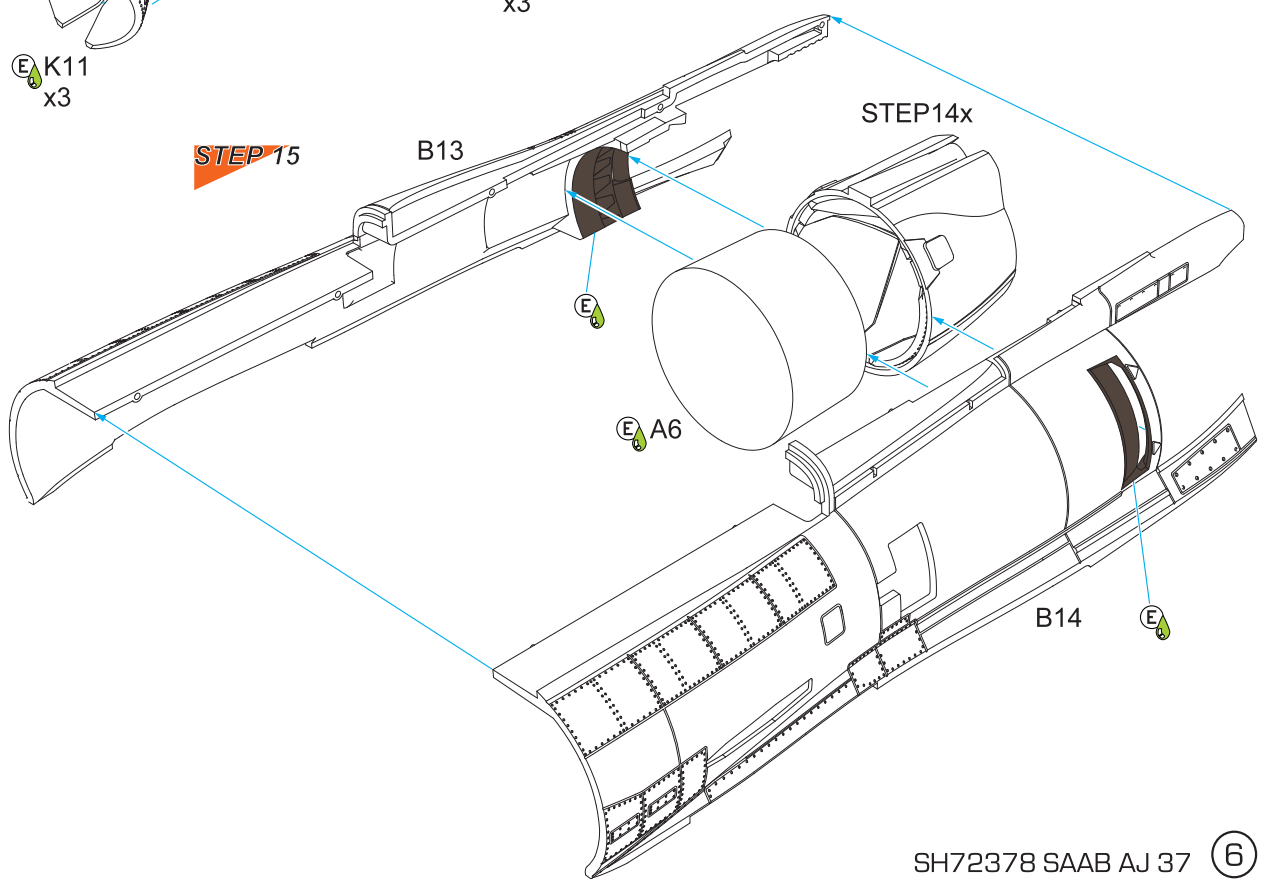

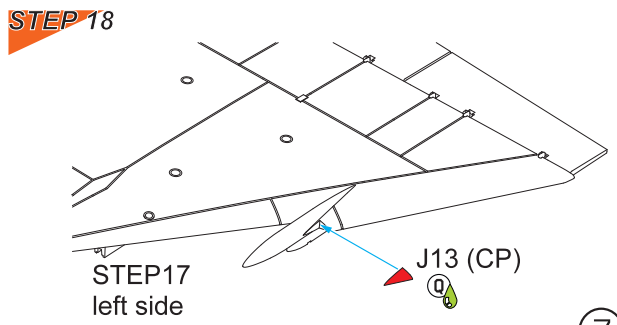
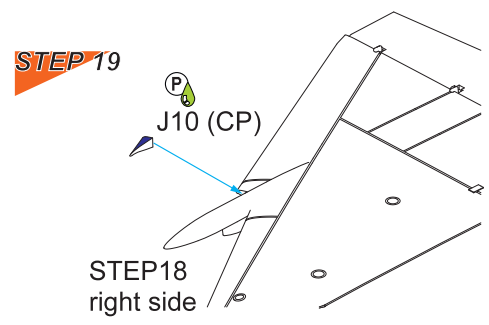
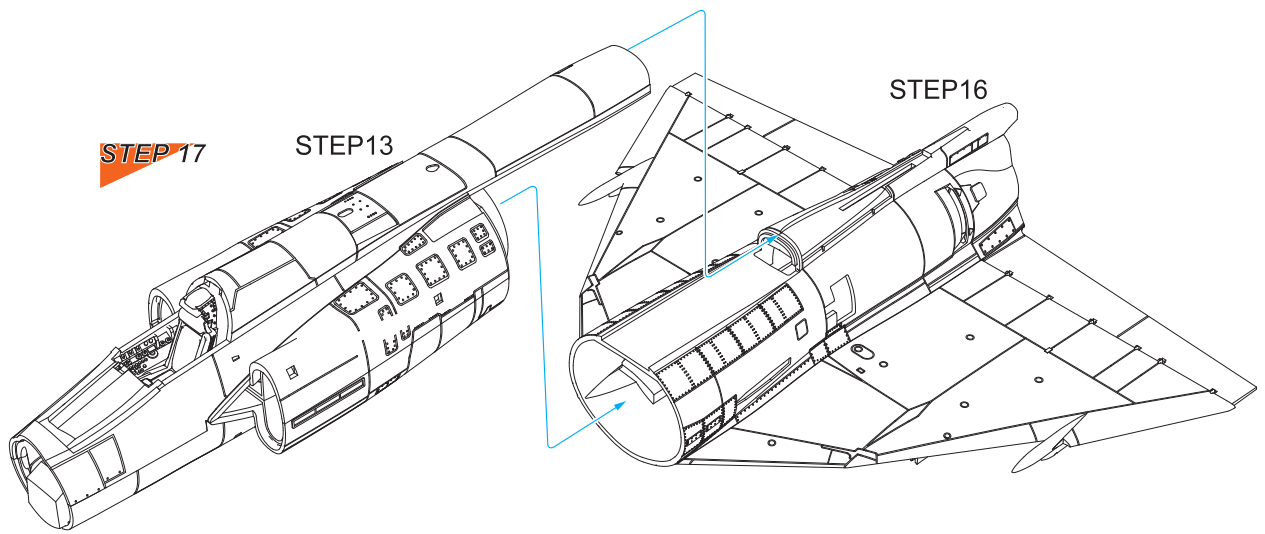
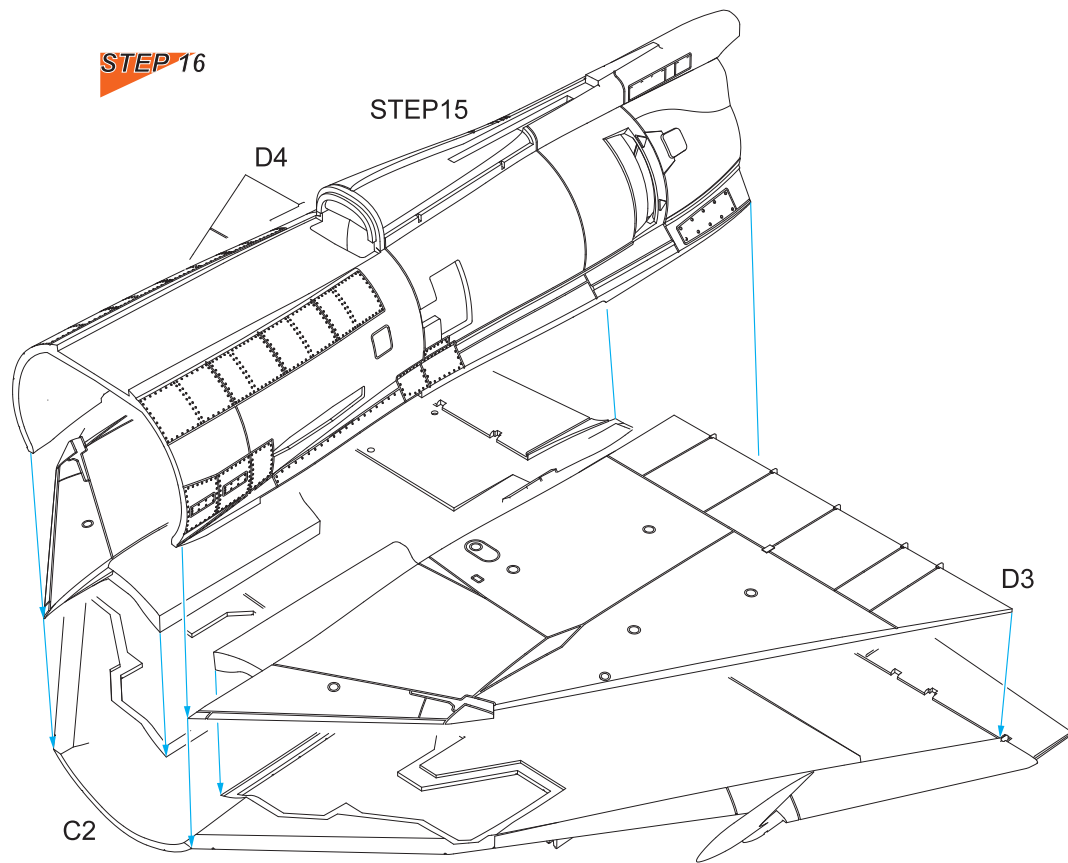

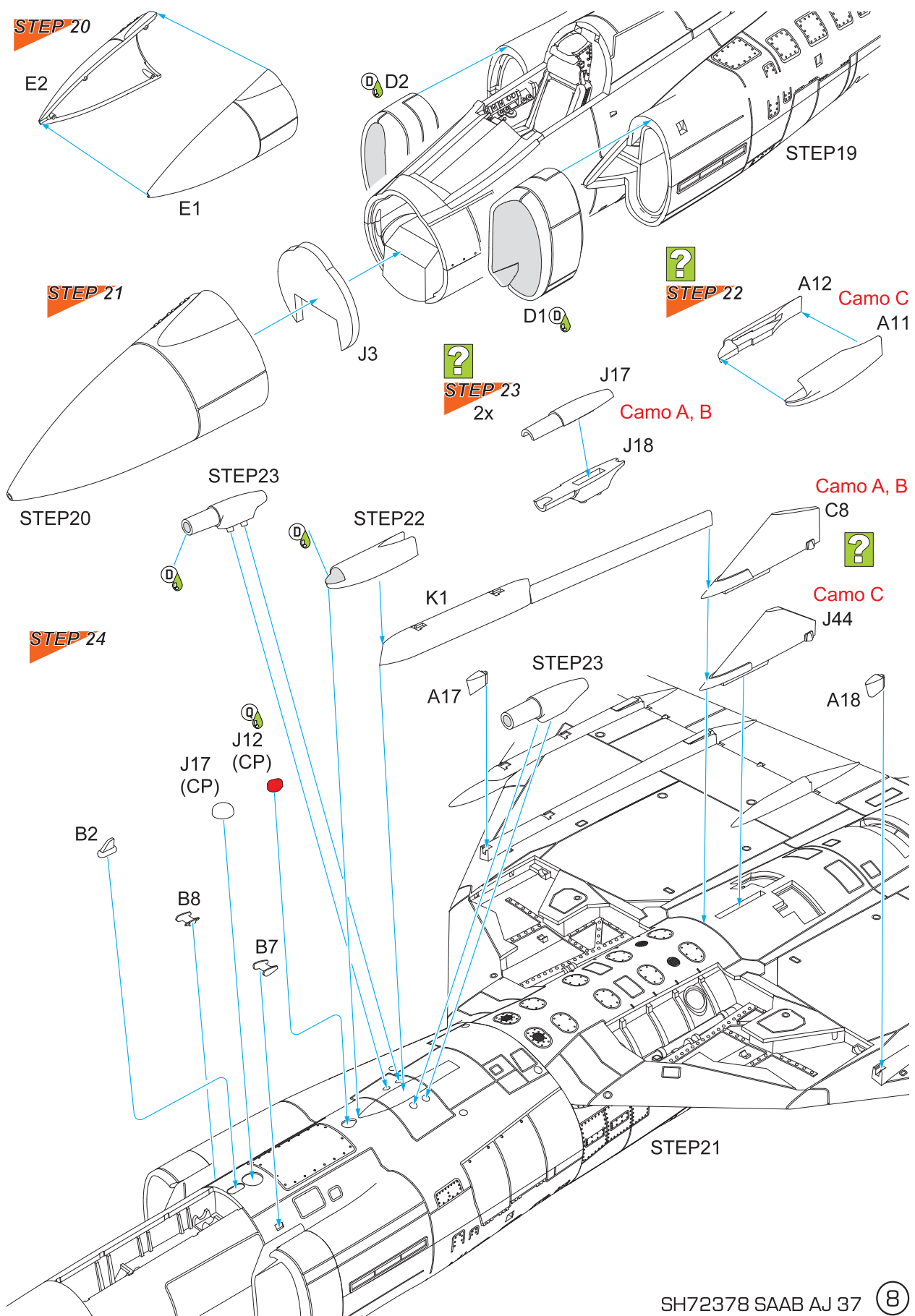

STEP 25

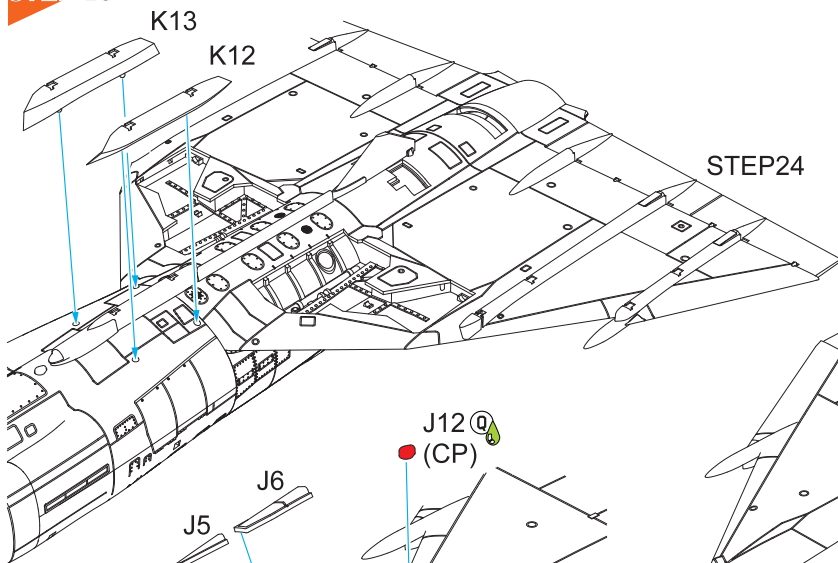

STEP 26

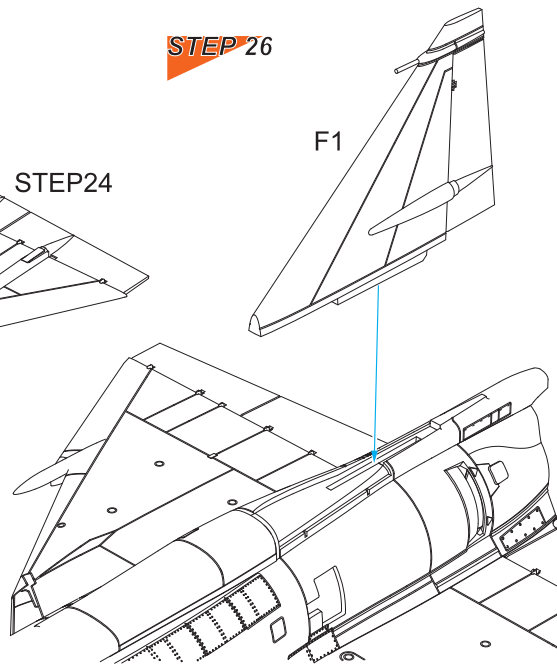

STEP 27

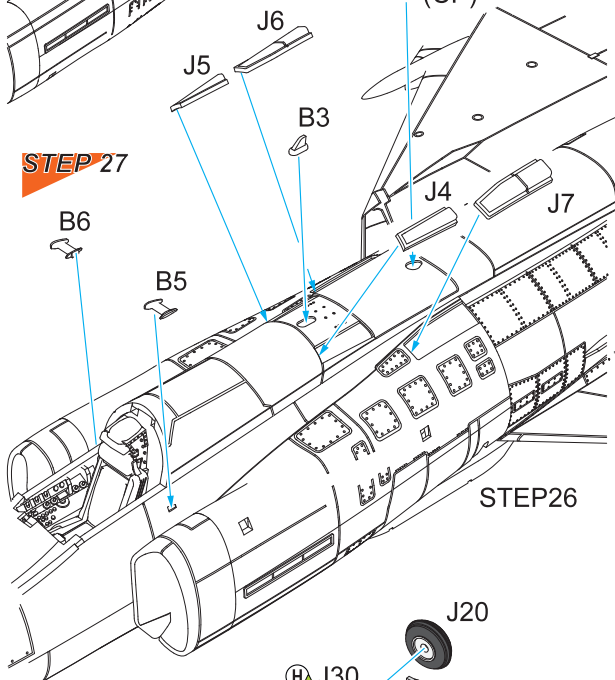

STEP 25

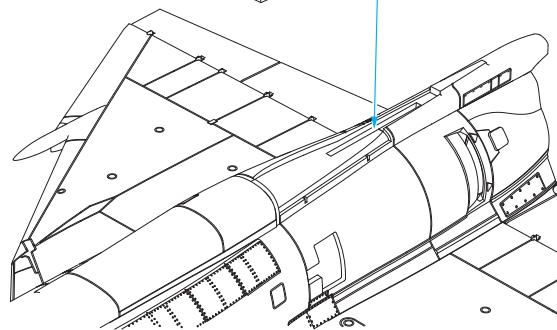

STEP 28

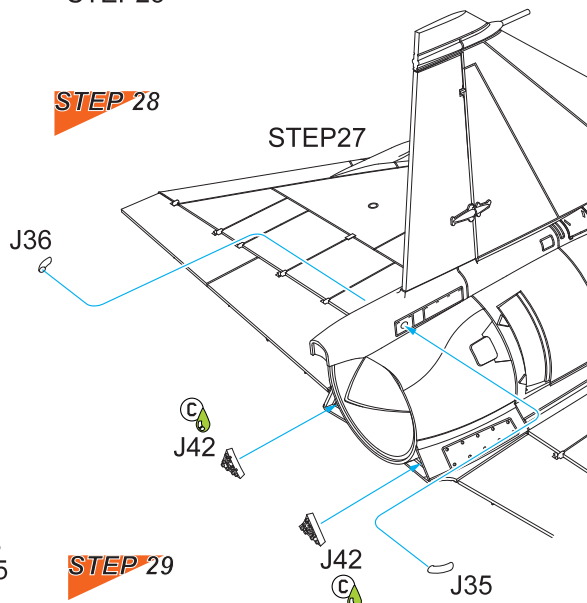

STEP 29

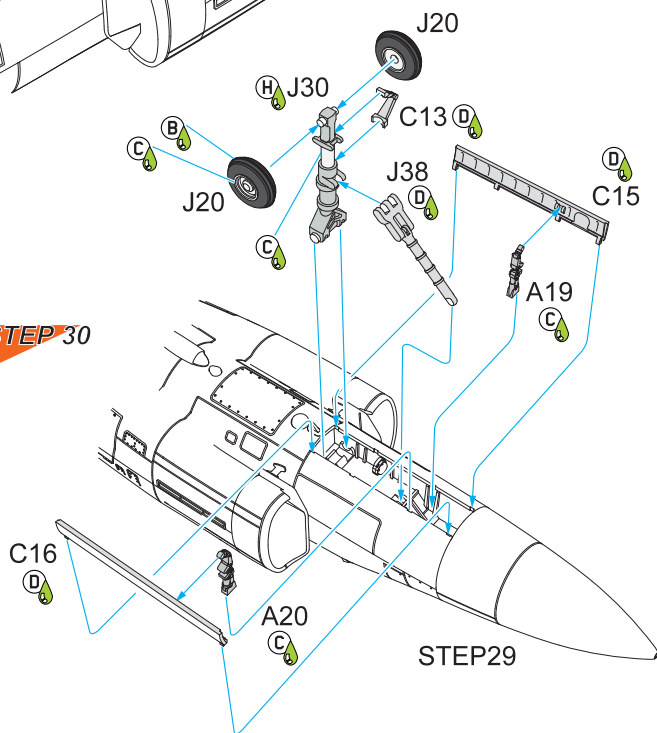

STEP 30

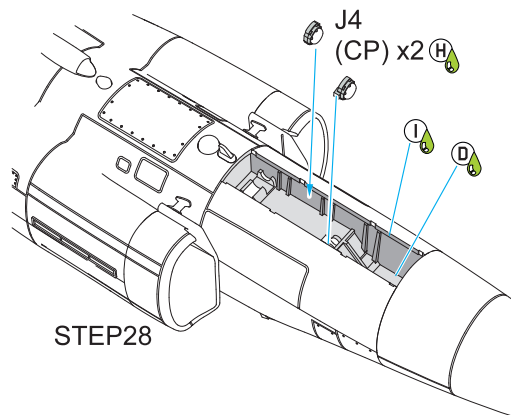

STEP 31

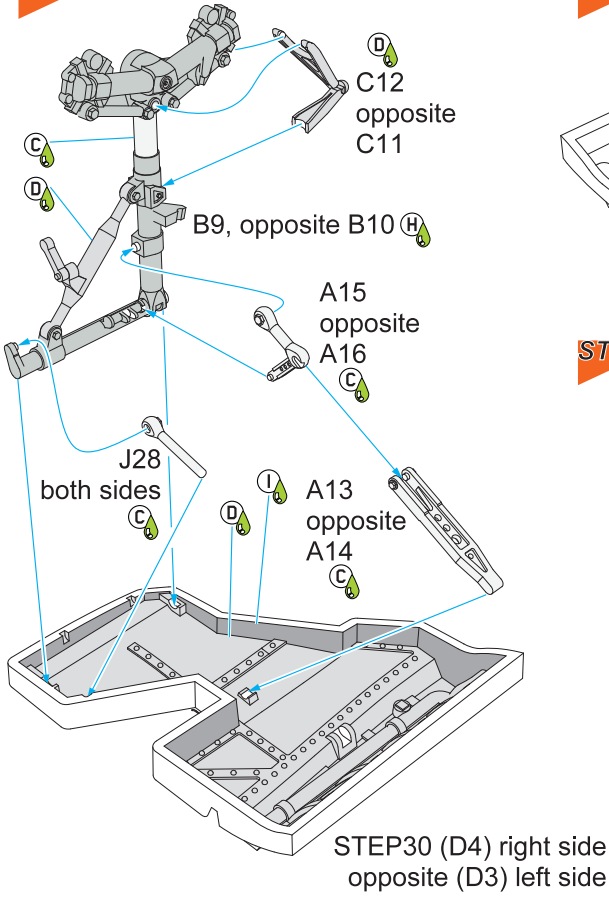

STEP 32

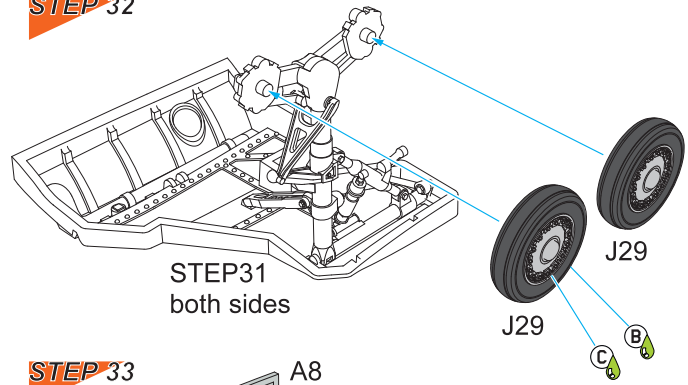

STEP 33

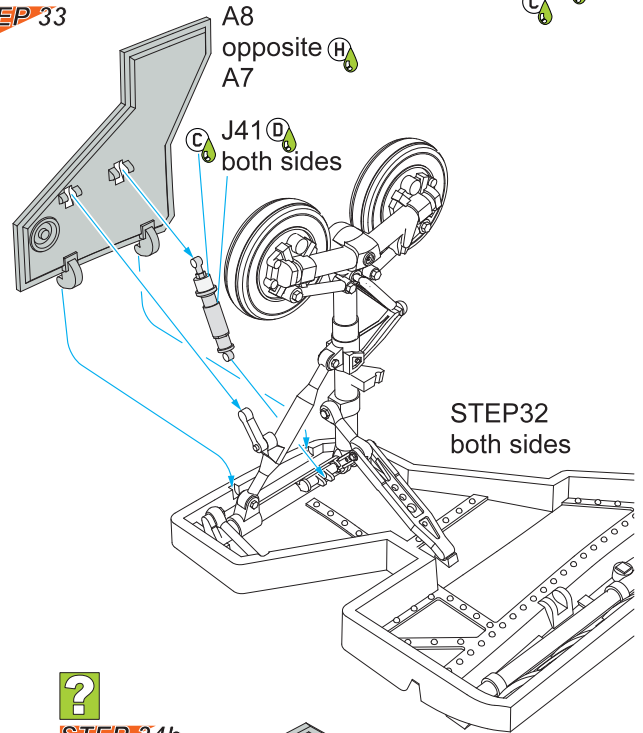

STEP 34a

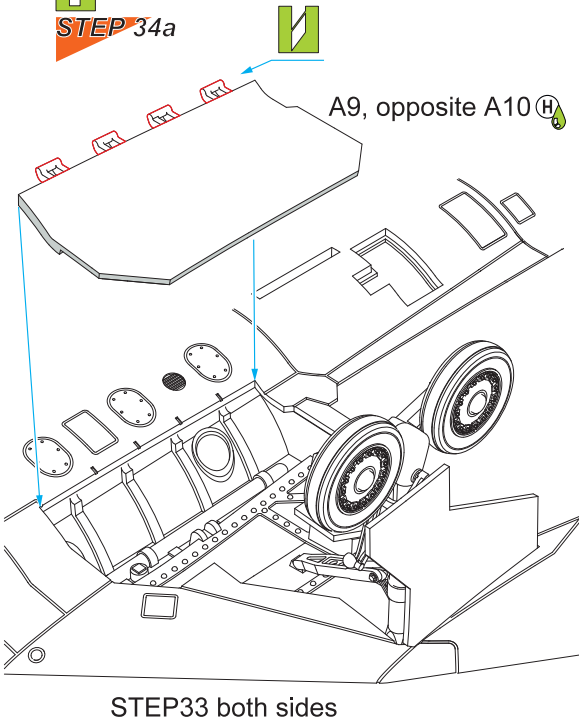

STEP 34b

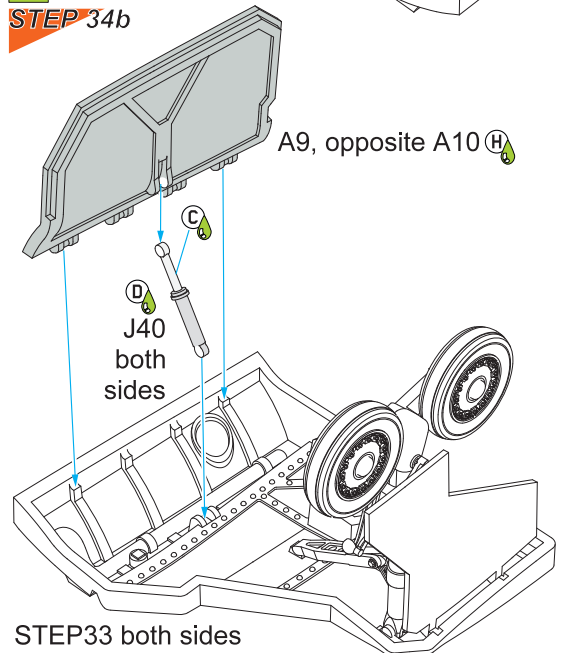

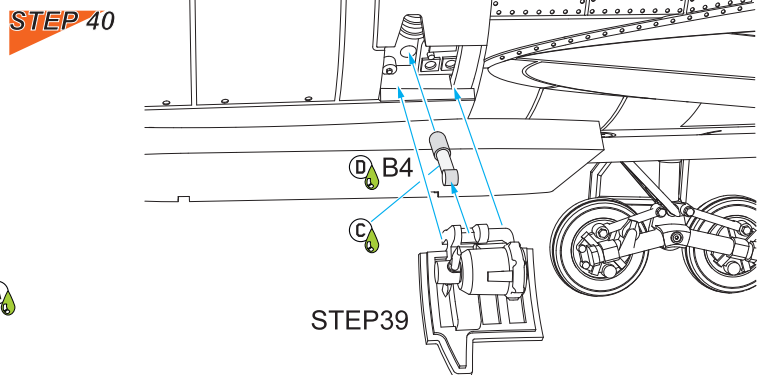
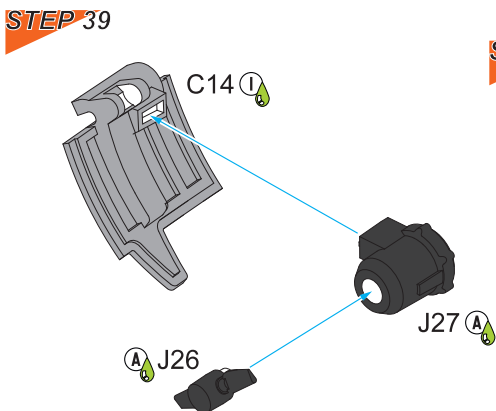
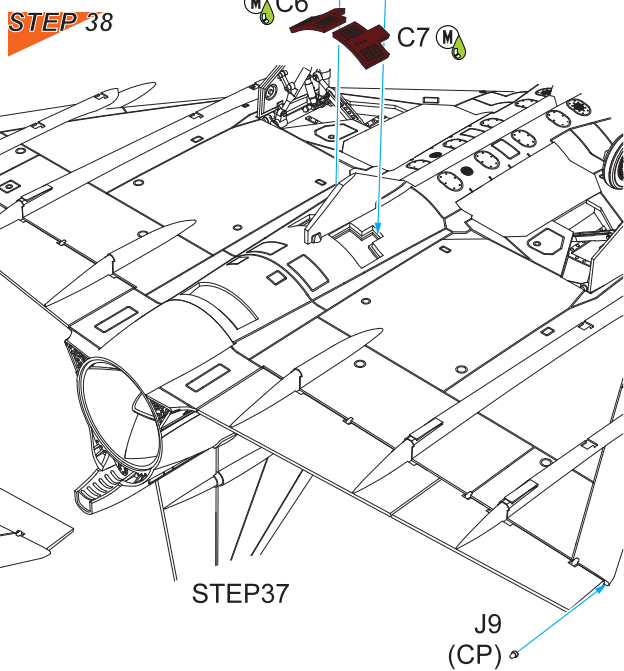
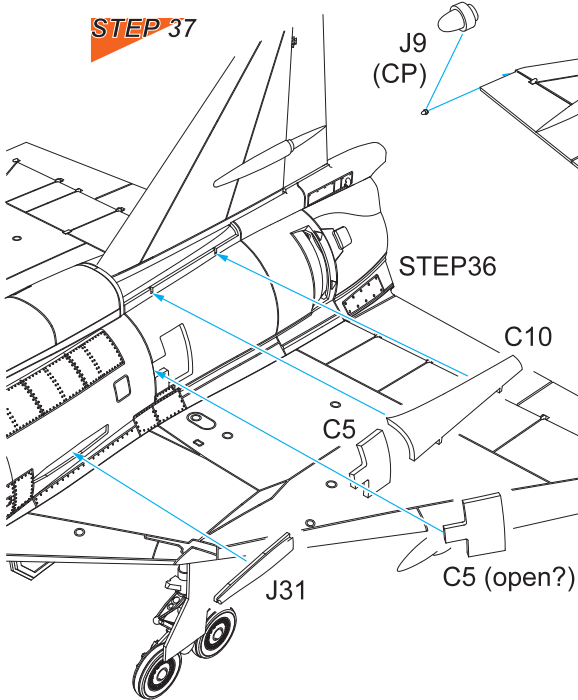
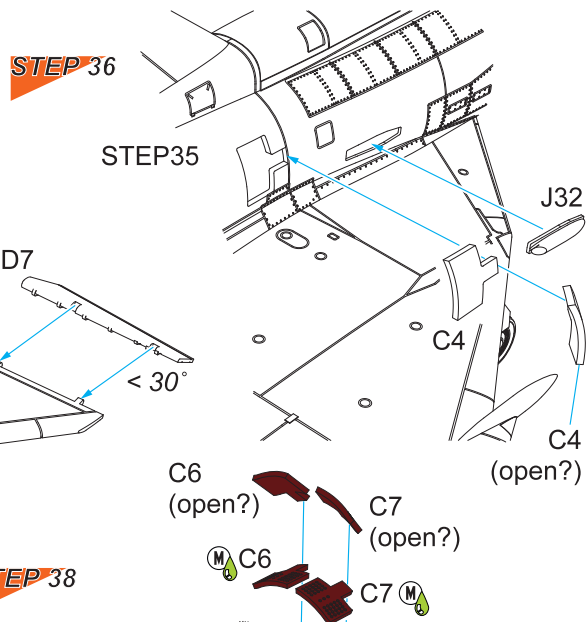
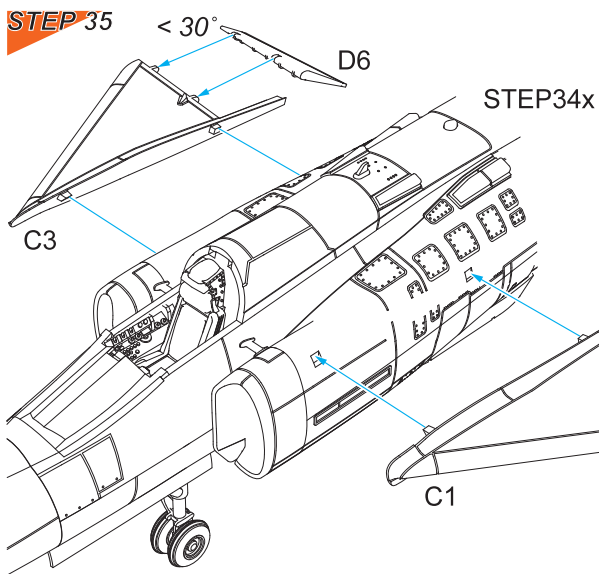

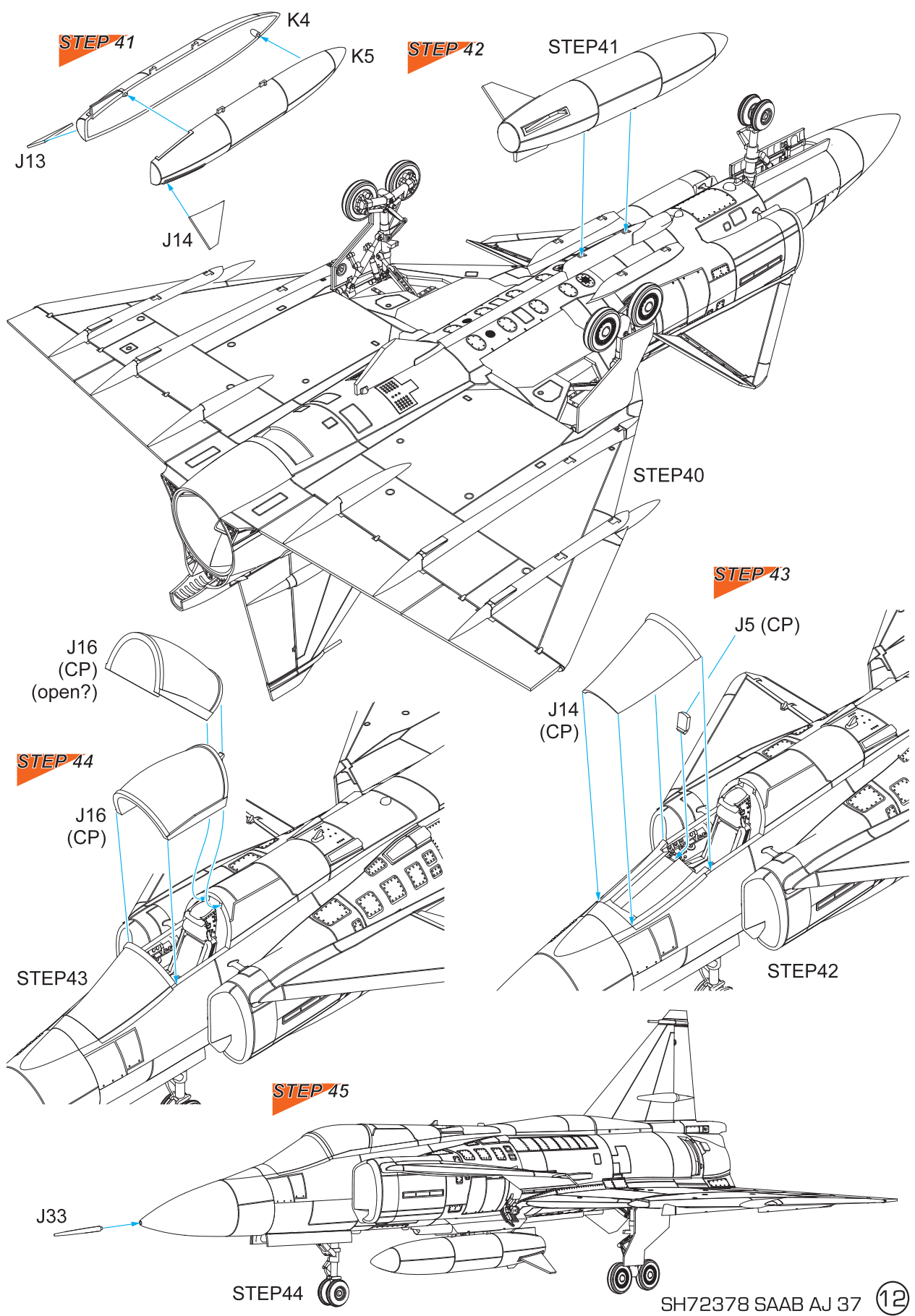

AJ-37 Viggen 37023/7-23/418, Wing F7, základna Sätenäs, červenec 1973. Stroj létající v barvě kovu nesl na trupu číslo 418, které dostal pro předvádění na Paris Air show 1973 o měsíc dříve. Při návratu do Švédska přistál 7-23 na holandské základně Leeuwarden pro doplnění paliva. Příslušníci tamější No.323 Squadrony RNLAF ozdobili levou stranu SOP 7-23 znakem své squadrony. 7-23 měl namontován pod trupem kýl typický pro první vyrobené kusy AJ 37 a byl vybaven dvěma nasávací pod trupem.

AJ-37 Viggen 37023/7-23/418, Wing F7, Sätenäs, July 1973. The bare-metal machine wore fuselage number 418 which she had got for her appearance at the 1973 Paris Air Show the month before. While on her route back to Sweden, 7-23 landed in the Netherlands on Leeuwarden air force base to refuel and the personnel of RNLAF No.323 Squadron adorned the port side of the tail fin with the badge of their unit. 7-23 was fitted with the ventral fin standard for the early production AJ 37s and also had a pair of belly air intakes.

CAMO. A

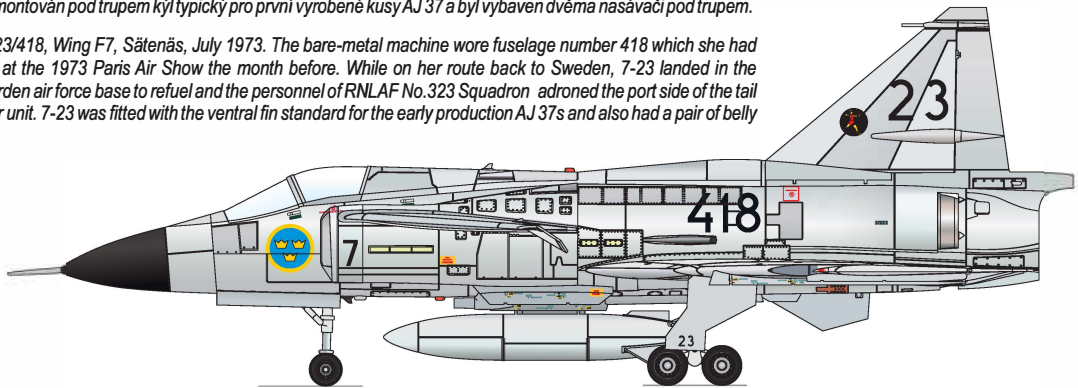

AJ-37 Viggen 37029/7-29, Wing F7, základna Sätenäs, červenec 1975. Znaky na trupu a SOP jsou památkou na účast tohoto stroje na Air show v tehdy západoněmeckém Buchelu, v září 1973. 7-29 měl namontován pod trupem kýl typický pro první vyrobené kusy AJ 37 a byl vybaven dvěma nasávací pod trupem.

AJ-37 Viggen 37029/7-29, Wing F7, Sätenäs, July 1975. The emblems on the fuselage and the tail fin commemorate this machine's appearance at the September 1973 Air Show at Buchel in the then West Germany. 7-29 also featured the early production style ventral fin and two belly air intakes.

CAMO. B

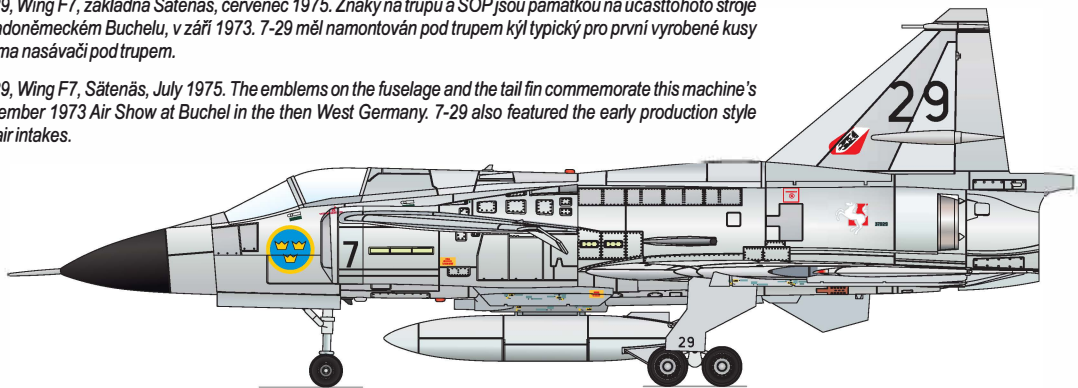

AJ-37 Viggen 37035/6-35, Wing F6, základna Karsborg, září 1984. Povrch stroje byl opotřebený, stejně jako číslo 35 na SOP. 6-35 měl namontován pod trupem kýl typický pro pozdější vyrobené kusy AJ 37 a byl vybaven jedním nasávacím pod trupem.

AJ-37 Viggen 37035/6-35, Wing F6, Karlsborg, September 1984. The exterior of the machine, as well as number 35 on the tail fin are rather worn down. 6-35 already sported the ventral fin of the variety normal for all the later AJ 37s and had just one air intake under her belly.

CAMO. C

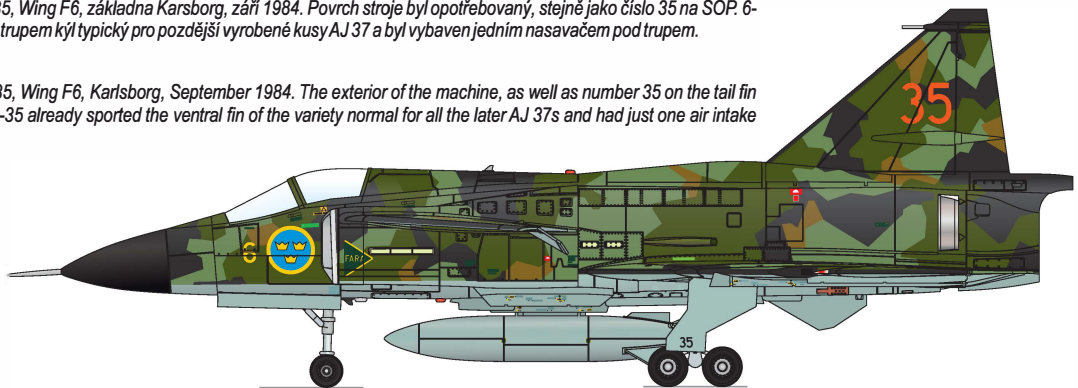

Star Dust
weathering pigments



The Razor Saw with Handle (cat. n. H1010) is a great tool for cutting both plastic and resin. CMK also offers a wide variety of coarse/medium/fine saws.

- H1000** Ultra smooth and extra smooth saw (2 sides – 70 teeth / 42 teeth) 1 pc
- H1001** Ultra smooth saw (both sides – 70 teeth / 70 teeth) 1 pc
- H1002** Very smooth saw (both sides – 42 teeth / 42 teeth) 1 pc

- H1003** Smooth saw (both sides – 31 teeth / 31 teeth) 1 pc
- H1004** Ultra smooth and extra smooth saw (2 sides – 70 teeth / 42 teeth) 5 pcs
- H1005** Ultra smooth saw (both sides – 70 teeth / 70 teeth) 5 pcs

- H1006** Very smooth saw (both sides – 42 teeth / 42 teeth) 5 pcs
- H1007** Smooth saw (both sides – 31 teeth / 31 teeth) 5 pcs
- H1010** Razor Saw with Handle 5 pcs

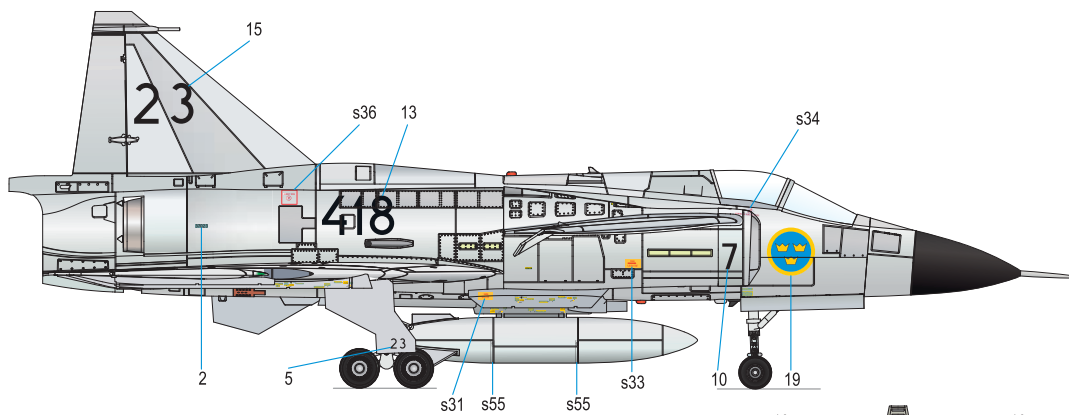

Natural Metal Finish
Přirodní kov
H8/C8

Black
Černá
H12/C33

Light Grey
Světle šedá
H324/C324

Red Brown
Červenohnědá
H47/C41

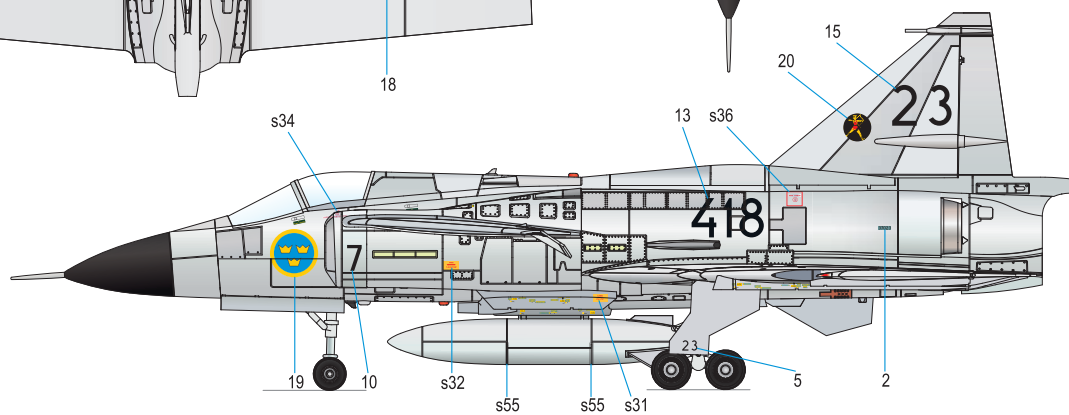
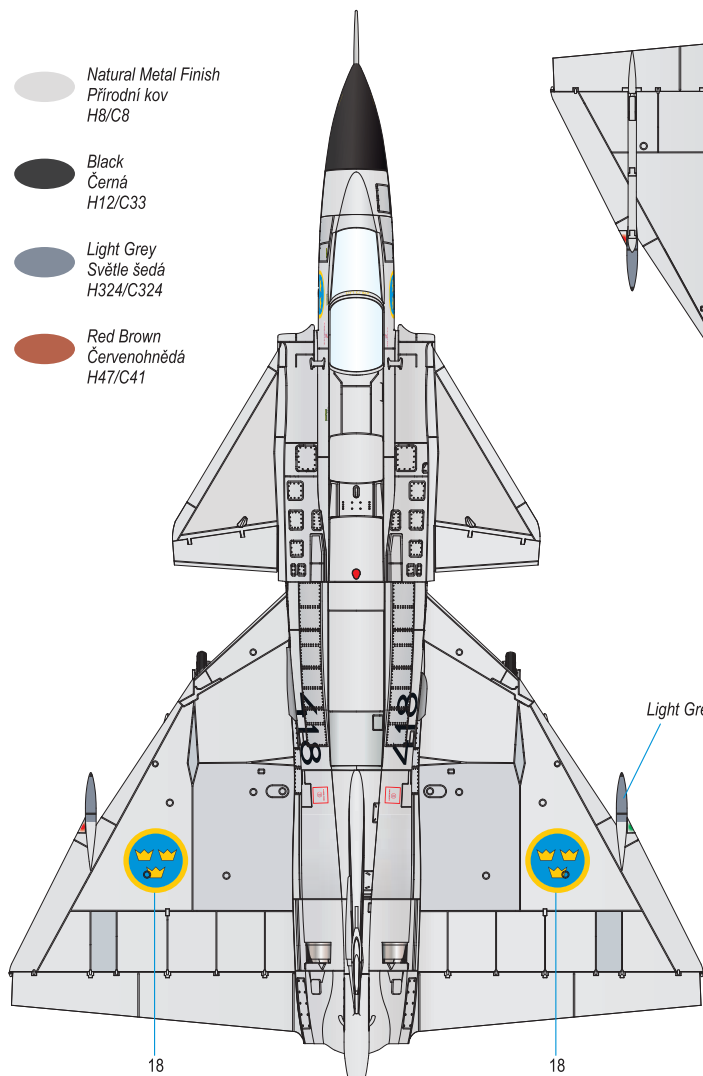
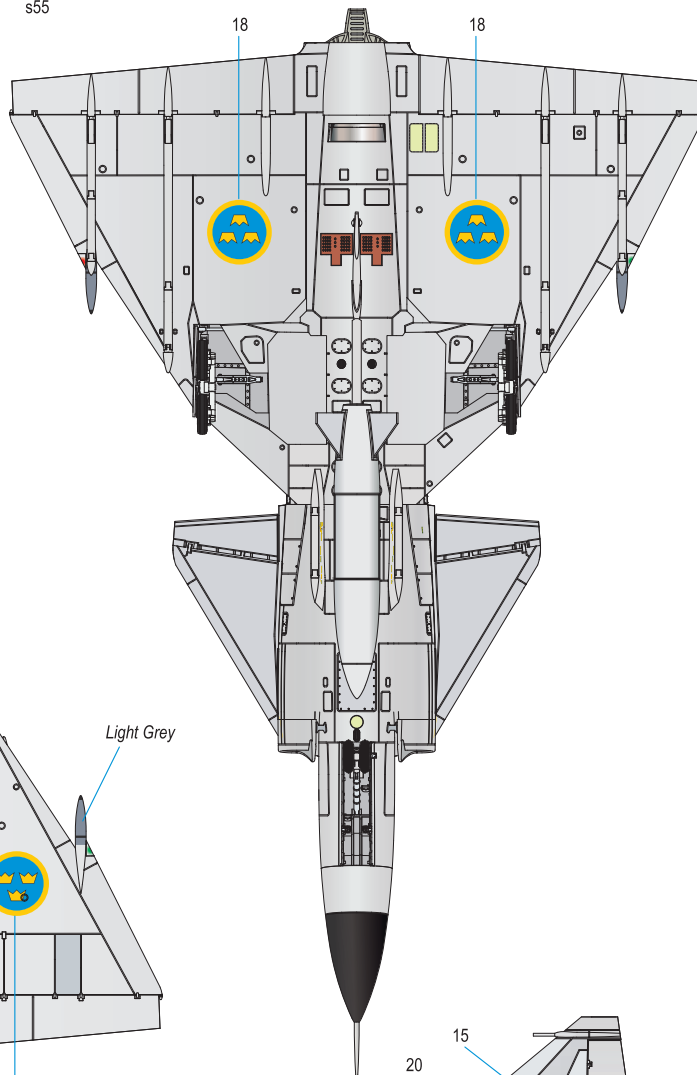

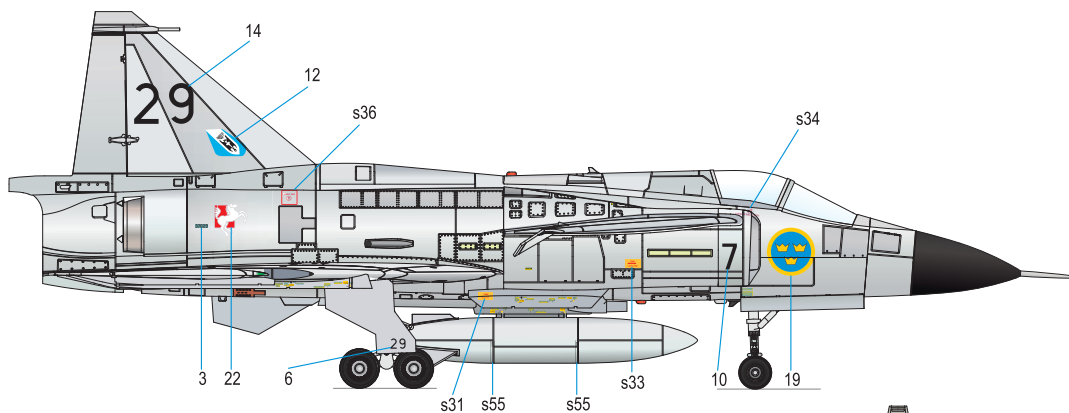

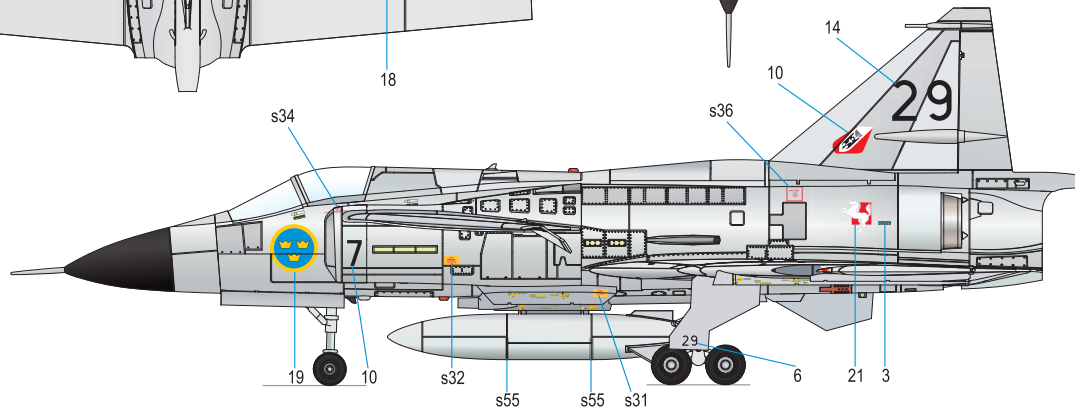
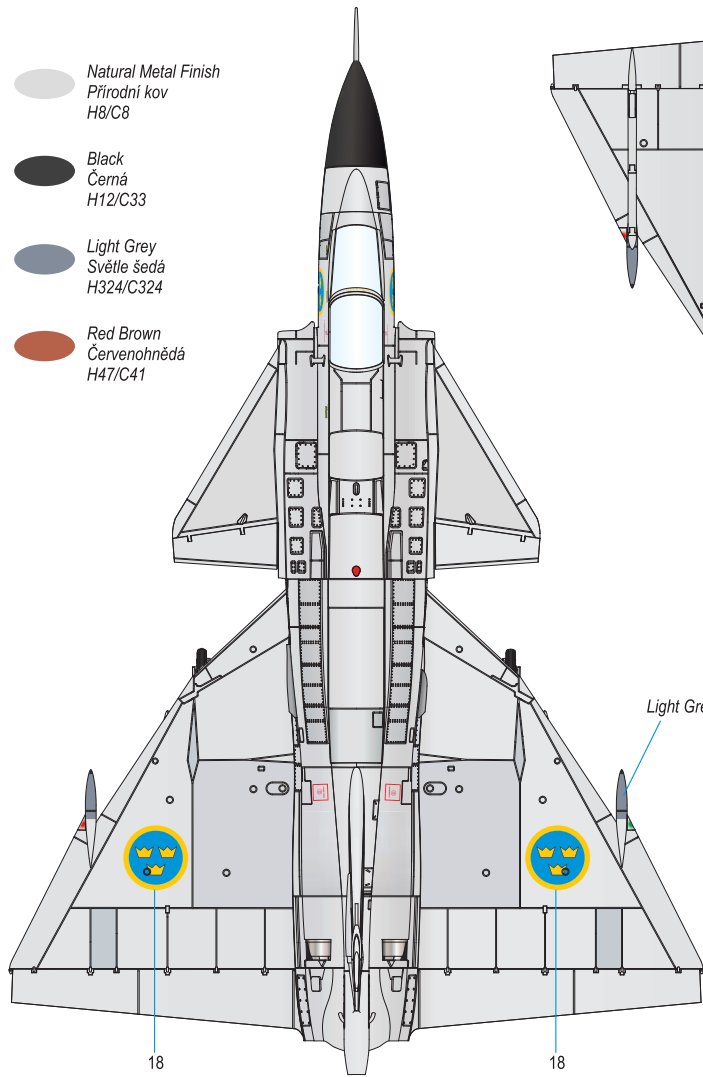
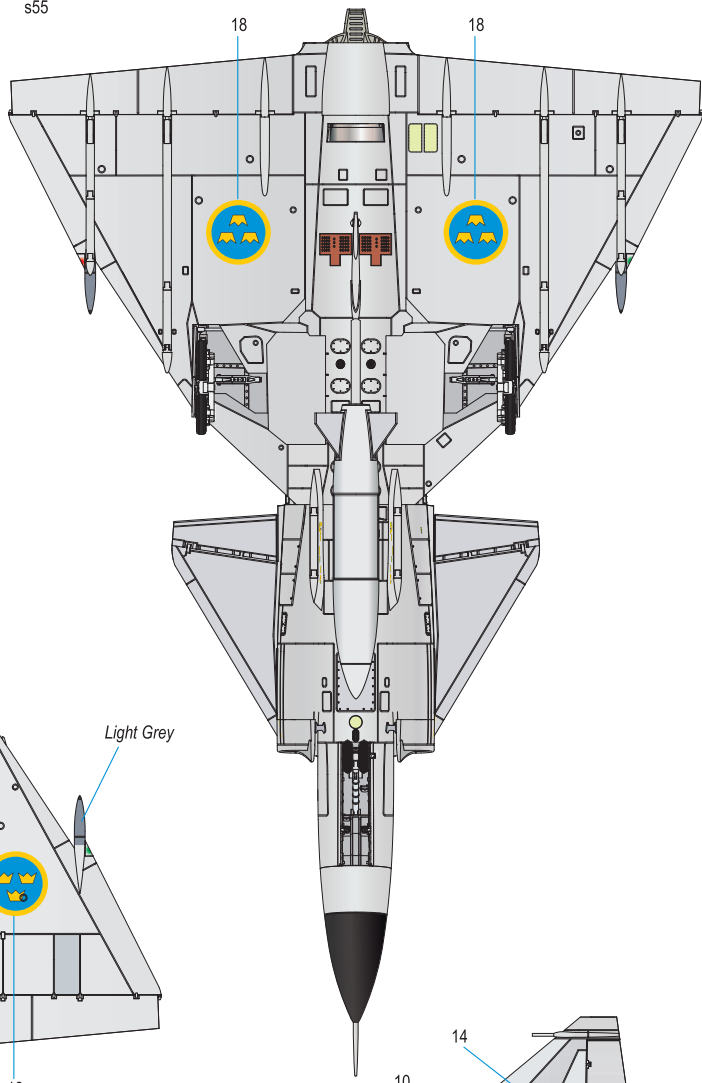

-  Natural Metal Finish
Přírodní kov
H8/C8
-  Black
Černá
H12/C33
-  Light Grey
Světle šedá
H324/C324
-  Red Brown
Červenohnědá
H47/C41

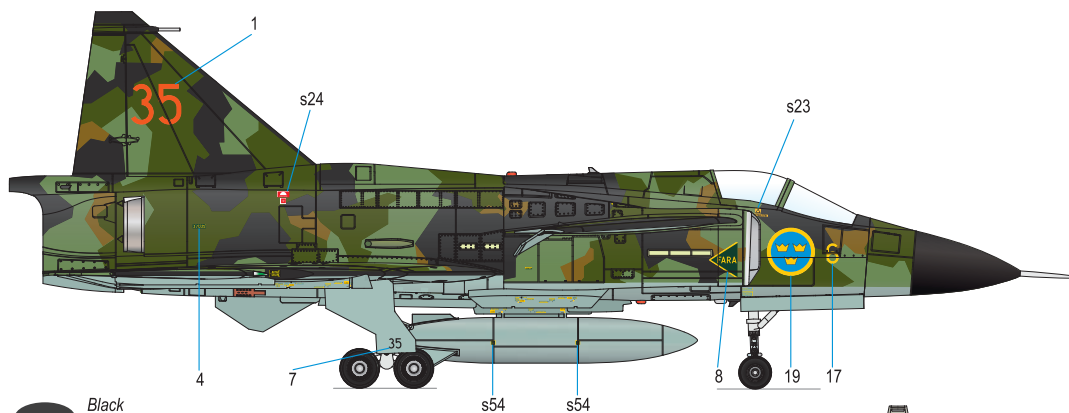



-  Black
Černá
H12/C32
-  Dark Green
Tmavě zelená
H309/C309
-  Light Green
Světle zelená
H58/C27
-  Tan
Světle hnědá
H310/C310
-  Light Grey
Světle šedá
H308/C308
-  Red Brown
Červenohnědá
H47/C41
-  Aluminium
Hliník
H8/C8

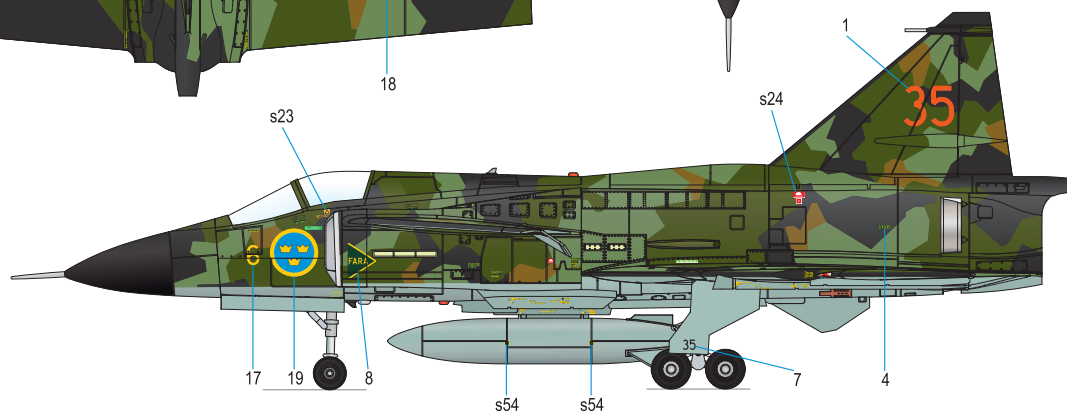
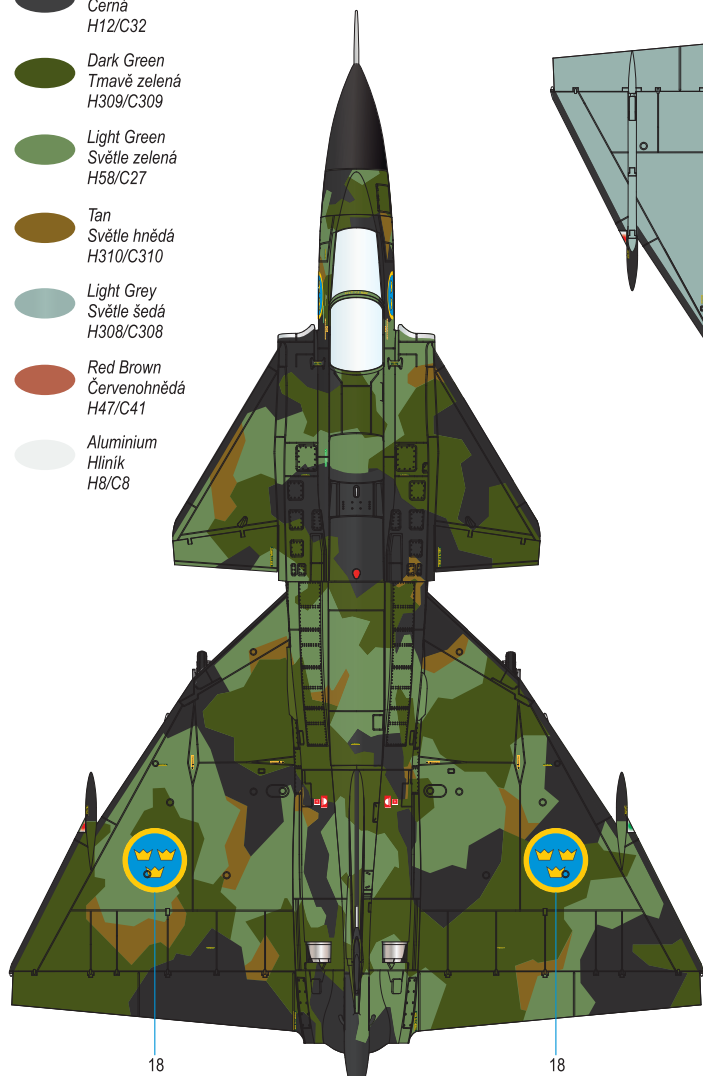
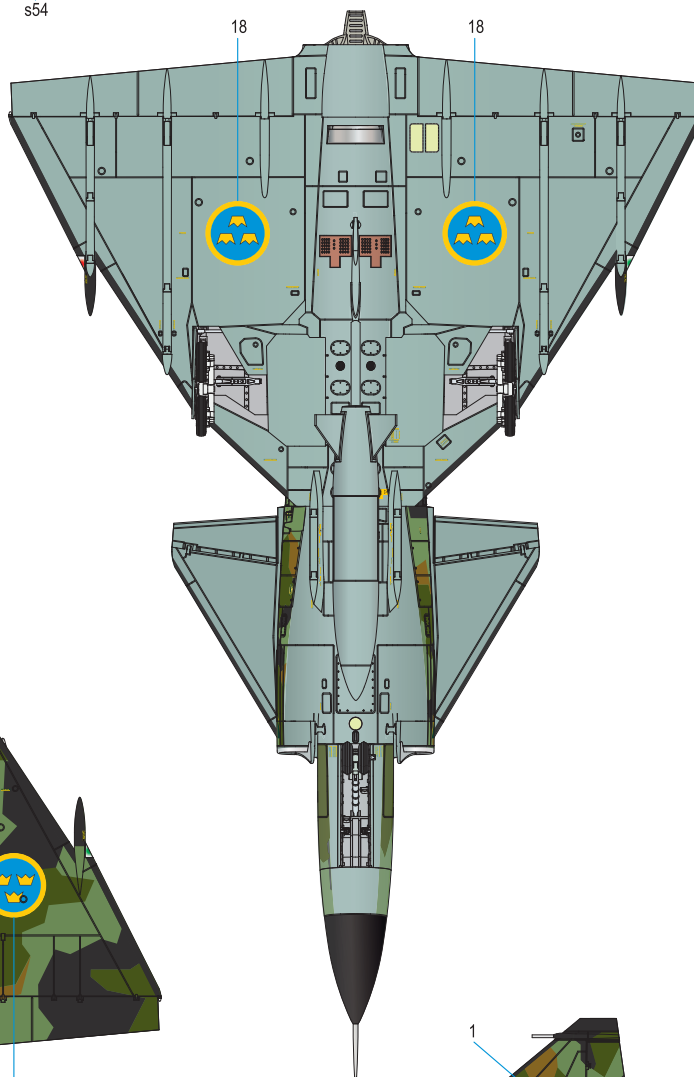

Universal Stencil Placement Scheme

(note: some stencils may have not been used on your chosen machine, always check photos and marking schemes)

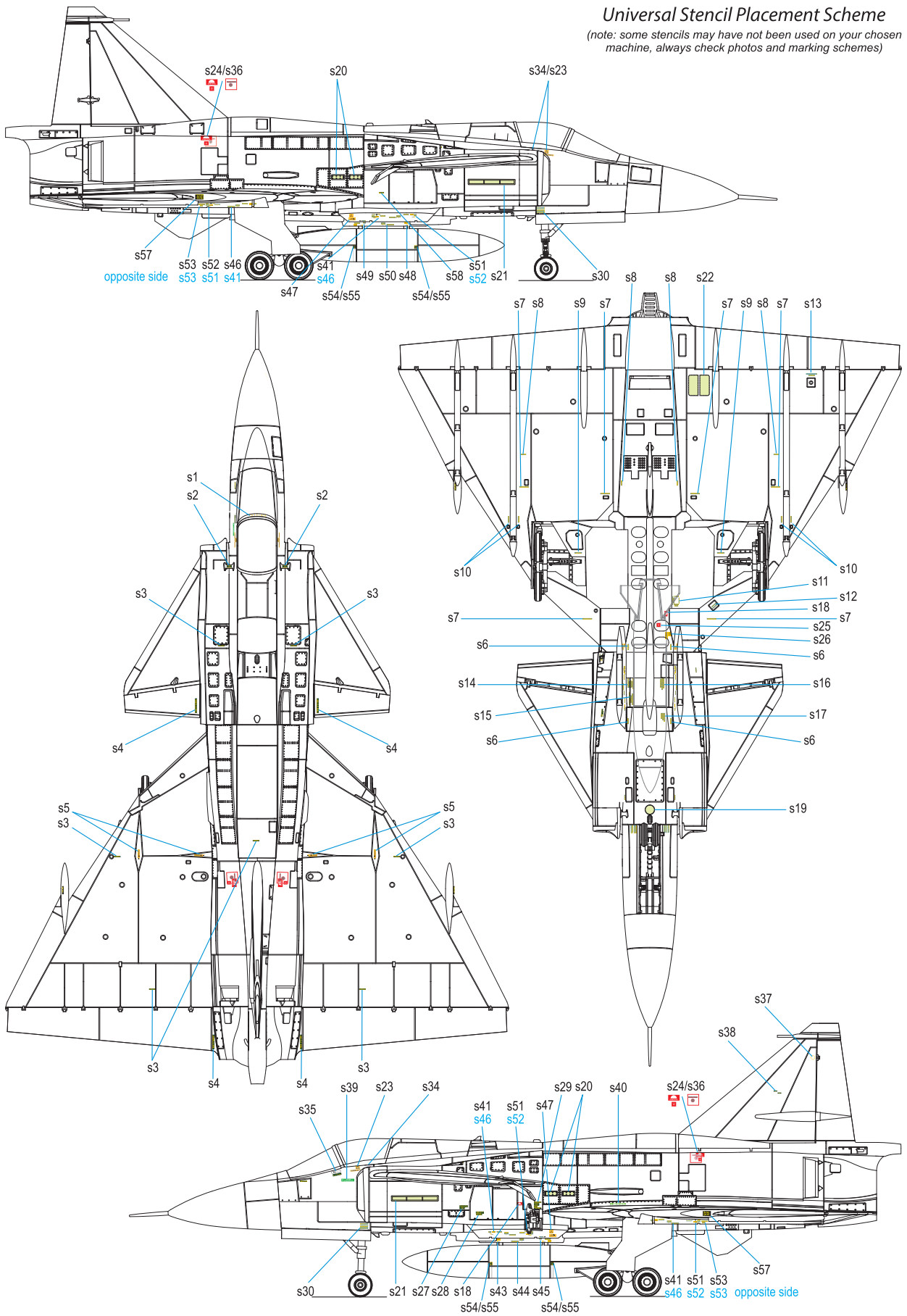

SPECIAL HOBBY 1/72 MIRAGE F.1 KITS & CMK RESIN SETS



SH72291 1/72
Mirage F.1B

SH72386 1/72
Mirage F.1 EQ/ED



SH72388 1/72
Mirage F.1C/ C-200
'Armée de l'Air'



Q72249 Mirage F.1
Cyrano IV Radar with
Pressurized Casing

Q72250 Mirage F.1
Cyrano IV Radar with
Uncovered Scanner Dish



Q72252 Mirage F.1
Afterburner Unit and
Engine Nozzle



Q72251 Mirage F.1
Wheels set



Q72253
Mirage
F.1C/C-200
MB Mk.4 Seat
(1 pc)



Q72254
Mirage
F.1CR/CT
MB Mk.10 Seat

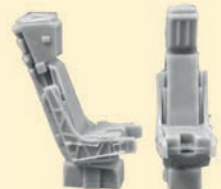

Q72255
Mirage F.1B
MB Mk.10
Seat (2 pcs)



Q72311 Remora
Radar Jammer Pod
for Mirage F.1 and
Mirage 2000



Q72312 Sycomor
Chaff / Flare Dispenser
for Mirage F.1



7306 GBU-24
Paveway III Laser
Guided Bomb (2 pcs)

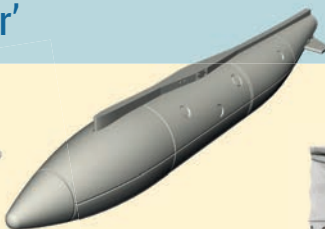

7355 Mirage F.1- RPL-201
'Irakien' Centreline tank



7361 Matra F2 Rocket Pod
(4 pcs)



F72305 French pilot and two
mechanics for Mirage F.1C model



F72308 Two French Pilots and
a Mechanic for Mirage F.1B Model

SH72417 SMB-2 Super Mystère / Sa'ar Duo Pack & Book

Super-Mystère

For Israeli Air Force Enthusiasts
Rafan Weiss
Super Mystère and Sa'ar
Israel AF Mini Photo Album
No.4
IsroDecal

MAKING YOUR MODELLING EASIER
M72001 Super Mystere SMB.2
for Special Hobby and Azur/From kits

Special MASK
M72001 Super Mystere SMB.2 1/72
For Special Hobby and Azur/From kits

F-14A Tomcat CMK sets for Academy kit



7452
F-14A Tomcat
Cockpit



7453
F-14A Tomcat
Port Side
Cannon
Installation



7454
F-14A Tomcat
Port Engine

AH-1G/Q/S CMK sets for Special Hobby and Revell kit



Q72330
AH-1G Early
Emerson Electric
TAT-102 (single
weapon) turret



Q72331
AH-1G
Emerson
Electric M28
(dual weapon) turret



Q72338
AH-1Q/S
Hughes M65
Telescopic
Sight Unit



F72349
AH-1
Sitting pilots
(2 figures)
and ground
crew
(1 figure)

Special HOBBY



facebook.com/specialhobby

WWW.SPECIALHOBBY.EU | WWW.CMKKITS.COM

CMK
CZECH MASTER'S KITS

1/72 SH72364



M72027

A.W. Meteor NF Mk.14 Mask

Special MASK

A.W. Meteor NF Mk.14
'The Last of Night Fighters'

1/72 SH72451 SF-260 Duo Pack & Book

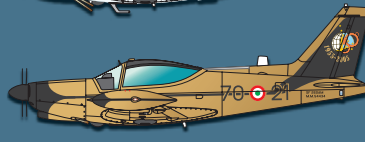
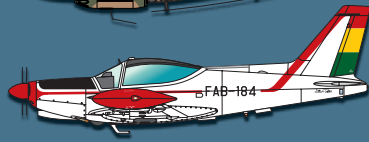
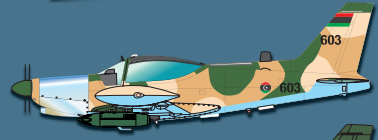
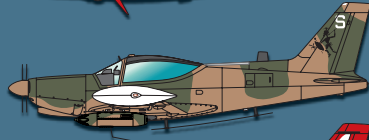
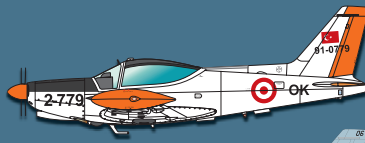
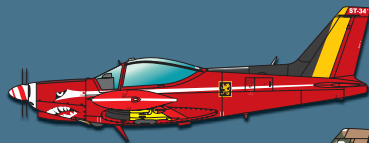

CMK SETS for VIGGEN kits 1/72



Q72343
SAAB Viggen
Thrust Reverser

Q72344
SAAB Viggen
Air Brakes
Set



Q72355
AJ/SK/SH-37 Viggen
Control Surface



Q72346
SAAB Viggen
Ejection
Seat



7328
Bofors m/70
Rocket pod (2 pcs)

Q72347
SAAB Viggen
Ram Air Turbine (RAT)



Q72345
SAAB Viggen Wheels

F72352
1/72 SK-37/SK-37E
Viggen Instructor/
Operator (seated in
rear cockpit) and
Pilot Climbing
Ladder into cockpit

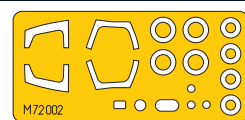

M72002
SAAB 37 Viggen
Single Seater Mask

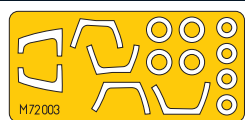

M72003
SAAB 37 Viggen
Two Seater Mask

Special MASK

Special HOBBY

facebook.com/specialhobby
WWW.SPECIALHOBBY.EU | WWW.CMKKITS.COM

CMK
CZECH MASTER'S KITS