

P.P. AEROPARTS  
MODEL  
ACCESSORIES

PP Models (Hambrook)  
8 York Close  
Stoke Gifford  
BRISTOL  
BS12 6NU

TOOLS YOU WILL NEED FOR THE ASSEMBLY OF THIS KIT

Sharp bladed craft knife, several spare blades, Stanley knife or small chisel, tweezers, small pliers, 6 inch steel rule, flat and round Swiss files, fine scissors, good quality paint brushes (size 0 or 2). A small vice will be needed too.

PAINTING SUGGESTIONS

Metal parts are best primed with an etching primer prior to application of the colour finish. Suitable primers are available from some specialist model shops, especially railway shops, or from car accessory shops. These paints are usually cellulose based and will require suitable thinner and brush cleaner; do not use white spirit, it won't work!

These primers chemically bond to the metal giving the next layer of paint a much more secure grip. Enamels and acrylic paints can be applied over cellulose surfaces but not the other way round! Cellulose solvents will attack other paints and will blister.

GA705 RAF Houchin Ground Power Unit

This highly detailed kit features a number of high quality white metal castings, photo-etchings, waterslide transfers (decals), wire and styrene rod, as well as fully illustrated assembly instructions. It has been prepared from measurements taken from a real example of this equipment at RAF Binbrook in 1986.

Once assembled and painted this kit will be an ideal addition to your model aircraft dioramas, as the real item is a very common sight on modern airfields. It is used to supply aircraft with both DC and AC electrical power for starting, maintenance and other purposes. This version is used on all light and medium aircraft types, and as the plugs are a NATO standard type can even be seen used on non-RAF aircraft.

Sockets for the plugs are located in a great variety of positions on different aircraft, and a few suggestions are illustrated. However we recommend checking in other references for details of socket locations for your particular application. We have found that many photos published of RAF aircraft feature this equipment in the background so you should have no difficulty in locating this information. Aeroguides, RAF Yearbooks, magazines such as Scale Aircraft Modelling, Scale Models International, Air International, Modelaid, and many many other books are excellent sources of such data.

We hope that you enjoy assembling this kit and that it makes a useful addition to your collection. In addition to our extensive range of other accessories, we have a large number of other models in preparation, so watch our adverts in the modelling press for details. A catalogue and price list is available, as well as a Newsletter for regular customers. Please write for details.

CASTING GENERAL INSTRUCTIONS

The white metal castings that make up the bulk of this kit are made with a high quality alloy to ensure that the fine detail is accurately resolved. However this metal is hard and requires careful handling. Any distorted parts can be gently bent back to true, but excessive pressure will break the part. Several smaller parts are duplicated in case of breakage or loss.

Any mould marks can be cleaned off the components with a fine Swiss file, or a sharp scalpel blade used as a scraper or cutting tool. Great care should be exercised as the parts can be distorted or broken if excess pressure is applied.

Assembly can be done with a low temperature soldering iron, but unless you have a lot of prior experience do not attempt to assemble these models with such a tool. Modern cyanoacrylate and epoxy glues are just as efficient at joining these parts, and allow for some adjustment or even disassembly if a mistake is made. A slip with a soldering iron will result in irreparable damage!

Major parts can be held together with sticky tape or modelling clay while glue is applied and allowed to set. Smaller parts can be held in place with tweezers, or speared with a scalpel blade tip, dipped into a drop of adhesive and placed on the model. With Cyanoacrylate glues the joint will be made immediately, so be sure the parts are correctly located! Debonding agents can be used should an error be made, or the joint can be parted with careful levering with a blade, but be sure all hardened glue is removed before the joint is remade. Otherwise the part will not seat correctly, and the new glue will not set well.

ETCHING GENERAL INSTRUCTIONS

The photo etched parts included in this kit are made from 8 thou. (0.2mm) brass, and require careful handling during assembly. Again, several of the smaller parts are duplicated in case of loss or damage.

To remove parts from the frame, use a very firm cutting board surface, perspex, thick plastic card or a piece of plate glass will be ideal, and a strong sharp blade; a Stanley knife or small chisel. Place a finger tip, or piece of wood, on the part required, and carefully cut through the tags joining it to the frame. The finger or wood is there to stop the part flying off your work surface as the cut is made! Use a firm vertical pressure on the blade, and be very careful not to slip. Provided the edge is sharp, very little force will be needed. Any tag scars can be cleaned off with a fine file, holding the part in a pair of pliers to prevent distortion.

Folding of parts can be done in several ways, depending mainly on the size of the part concerned. Most folds are indicated by a half-etched groove on the reverse side. Support the part up to the groove with a firm grip, using pliers or tweezers for smaller parts, the edge of a steel rule or the jaws of a vice for the larger ones. Then using the flat of a scalpel blade, or (another!) steel rule, gently push the protruding part over until it is at the required angle. Check the instructions below for more detailed descriptions for each particular part. Remember this method depends on the parts being gripped and supported very firmly; a slip will probably distort the part beyond repair.

Parts list

Castings

- C1 Fuel tank
- C2 Chassis
- C3 Exhaust silencer
- C4 Spring
- C5 Spring
- C6 Axle
- C7 Spring
- C8 Spring
- C9 Turntable
- C10 Axle
- C11 Radiator
- C12 Cable bin
- C13 Cable bin
- C14 Side panel
- C15 Side panel
- C16 Top cover
- C17 Obstruction light
- C18 Obstruction light
- C19 Power indicator light
- C20 Power indicator light
- C21 Carburettor intake
- C22 Floodlight mast
- C23 Fire extinguisher
- C24 Wheel
- C25 Wheel
- C26 Wheel
- C27 Wheel
- C28 Tow frame
- C29 Power plug
- C30 Power plug
- C31 Fuel filler spout

Etchings

- E1 Instrument panel
- E2 Rear louvered grille
- E3 Tank protector plate
- E4 Tow shackle
- E5 Radiator door
- E6 Radiator door
- E7 Instrument panel door
- E8 Instrument panel door
- E9 Door handle
- E10 Door handle
- E11 Door handle
- E12 Door handle
- E13 Door handle
- E14 Door handle
- E15 Cable bin lid
- E16 Cable bin lid
- E17 Top cover lift eye
- E18 Top cover lift eye
- E19 Top cover lift eye
- E20 Top cover lift eye
- E21 Tow frame support
- E22 Tow ring latch

Thin copper wire  
Thick copper wire  
Styrene rod

Decal Sheet

Colour Details

These notes are based on the actual equipment studied at RAF Binbrook in mid-1986. These particular Ground Power Units have been in service for some time, and have been painted yellow and blue in previous periods. Check your references!! Many photos published in the specialist aviation magazines, books, RAF Yearbooks show aircraft on the ground with service equipment in evidence, so you should have no trouble finding suitable details for your particular model.

- Overall equipment - matt dark green
- Cables, tyres - dark grey (rubber)
- Obstruction lights - orange
- Power lights - one white, one green
- Exhaust silencer - rust or stainless steel

Yellow stripes, patches, and Royal Air Force wording can be added from the decal sheet. Many variations can be found so it is wise to check the exact location of these markings for your particular application. Some suggestions are given on the diagrams, but these are by no means comprehensive!! Decals are best applied to a gloss finish and then sealed with a matt or semi matt varnish.

Acknowledgments

Our grateful thanks to Sgt Peart of 11 Squadron at RAF Binbrook for his assistance with the research with this kit, John Adams of Aeroclub Models and Dave Rogers for additional material.

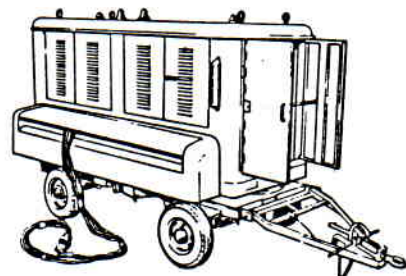

1 Chassis Assembly

a) Locate and glue the fuel tank C1 underneath the chassis casting C2, between the spring mounting blocks, as shown on the diagram.

b) Locate and glue two springs C4 and C5 into the spring mounting blocks, ensuring they are level with each other.

c) Locate an axle C6 into the notches in the springs C4 and C5, the moulded lugs on the axle locating behind the springs.

d) Similarly, locate the springs C7 and C8 into the spring mounting blocks on the front axle turntable C9. Again check that they are level, and then glue the front axle C10 between the springs.

e) The turntable assembly can then be glued into place under the chassis assembly, locating the mounting lug into the hole in the front of the chassis.

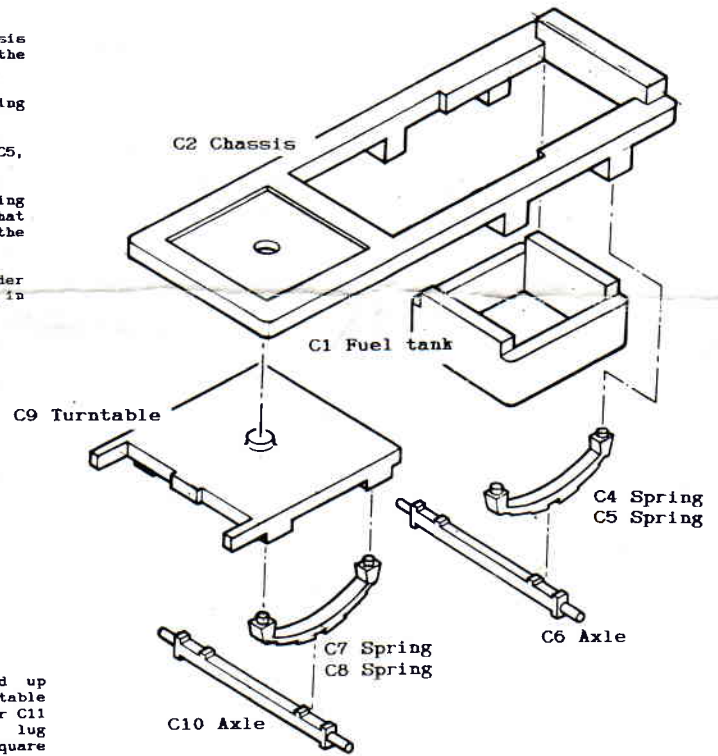

2 Box Assembly

a) Locate the radiator C11 onto the front chassis, butted up against the raised chassis edge, in front of the turntable location lug. The triangular gusset moulded onto the radiator C11 may need slight trimming to clear the front axle turntable lug protruding through the chassis. Check the radiator is square vertically as well as horizontally.

b) Test-fit the cable bins C12 and C13 onto the side panels C14 and C15, the lugs on the bins locating into the slots moulded in the lower edges of the side panels. These may need slight trimming to obtain a good fit. Then glue into place.

c) Cut two lengths of styrene rod (supplied) to represent the cable rollers. These can then be glued onto the top edge of the outside face of the bins.

d) Locate the side panel assemblies onto the chassis assembly, the cable bins resting against the sides of the chassis, and the side panels resting against the radiator C11. Check the ends of the side panels are level with the ends of the chassis.

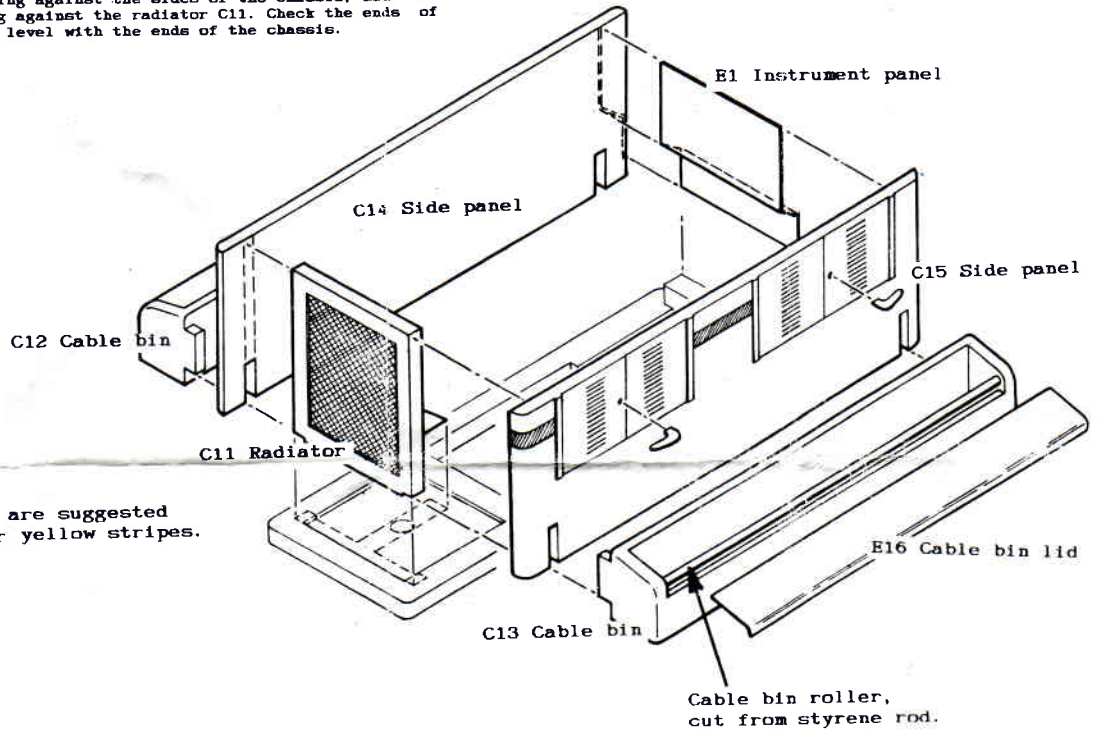

Shaded areas are suggested positions for yellow stripes.

e) Locate the top cover casting C16 onto the box assembly, checking it is correctly positioned; the end with the single light location is at the same end as the radiator C11. Then glue into place as illustrated.

f) Carefully bend the instrument panel E1 as shown, and then locate and glue into place in the rear end of the box. Then locate the rear louvred grille E2 over the lower section of the instrument panel and rib on the chassis C2. Note the fuel filler location is on the right side. Then trim the fuel filler spout C31 to length and to the correct angle, and glue into place as shown.

g) Fold the tow shackle location plate on the tank protector plate E3 over away from the fold groove, so that they lie back to back. Glue into place, and then glue the whole plate into place on the chassis below the rear louvred grille E2. The tow shackle E4 can then be folded as shown and then glued into place on the location plate as shown. Note the shackle is slightly splayed and not parallel.

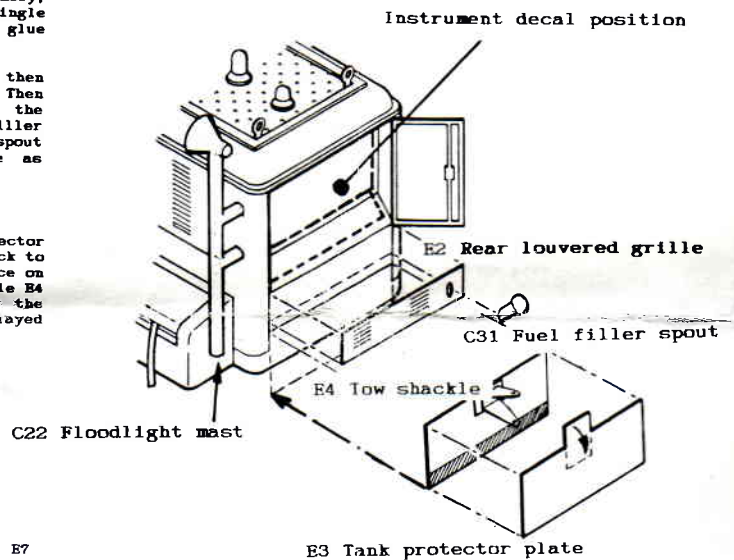

### 3 Door Assembly

a) The radiator doors E5 and E6, and instrument panel doors E7 and E8 should be folded away from the fold groove so that their respective interior detail panels lie on the inner surface of each door panel. They can then be glued carefully together. The doors can then be glued into place as shown in the diagram.

b) The door handles E9, E10, E11, E12, E13 and E14 can then be glued into place, as shown. Note alternate handle styles are included.

c) The bin lids E15 and E16 are then carefully folded as shown. This is best done using a vice, gripping the etchings between two pieces of thick styrene sheet. A radius on the inside piece will give the lids the curved bend required. See the diagram! Put the lids to one side as they will be fitted after the cables have been assembled; see below.

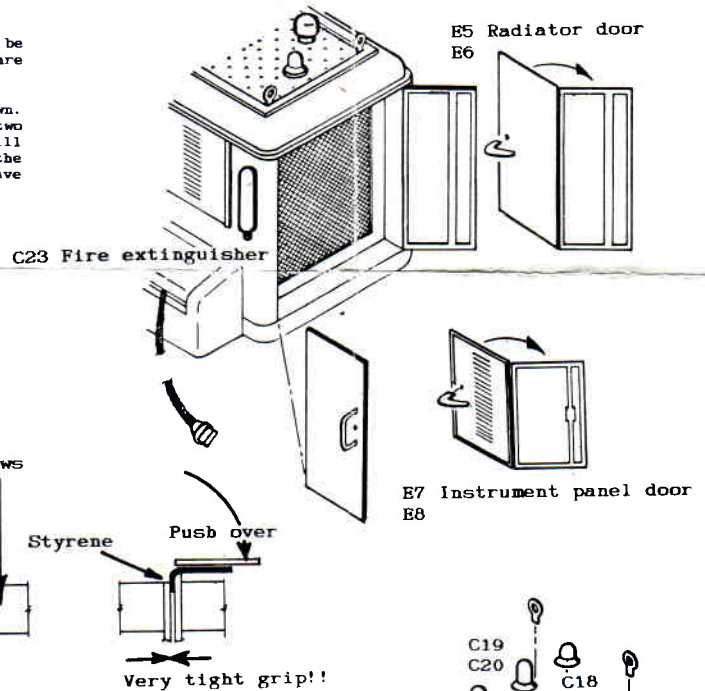

Method of bending bin doors

### 4 Top Cover and Other Details

a) Cut the smaller obstruction lights C17 and C18 from their sprue as shown and glue into place in the locations moulded on the top cover C16.

b) Repeat for the larger Power Indicator lights C19 and C20.

c) Trim the moulding tag on the carburettor intake C21 and then glue into place on the top cover C16 as shown.

d) Glue the lifting eyes E17, E18, E19 and E20 into place in the corners of the top cover C16.

e) The floodlight mast C22 can be glued onto the rear left side panel as shown if required.

f) Glue the fire extinguisher C23 into place on the right side panel as shown.

The model is best painted at this stage; see the colour notes for details. The instrument panel area should be painted light grey or yellow and the instrument decal applied when the paint has dried. Note the large dials are to the top.

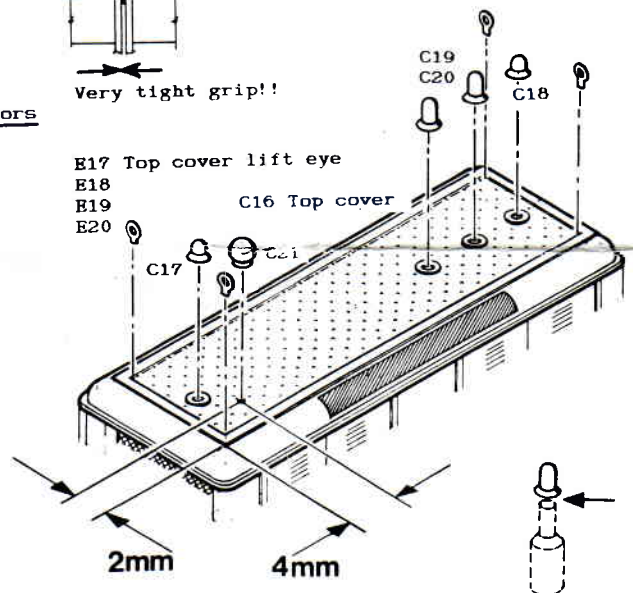

Cut away waste!

**5 Wheels and Tow Bar assembly**

- a) The wheels C24, C25, C26, C27 should be painted and when dry glued into place on the axles.
- b) The tow frame support E21 should now be folded as shown and then glued into place underneath the tow frame C28 as shown. Then glue the tow ring latch E22 into place behind the tow ring spring as shown. The frame can then be glued into place on the front axle turntable either resting on the ground or at the height required if the model is to be under tow.
- c) Cut a length of the thicker wire to represent the towframe lift bar and glue into place on the tow frame C28 behind the tow ring spring as shown.

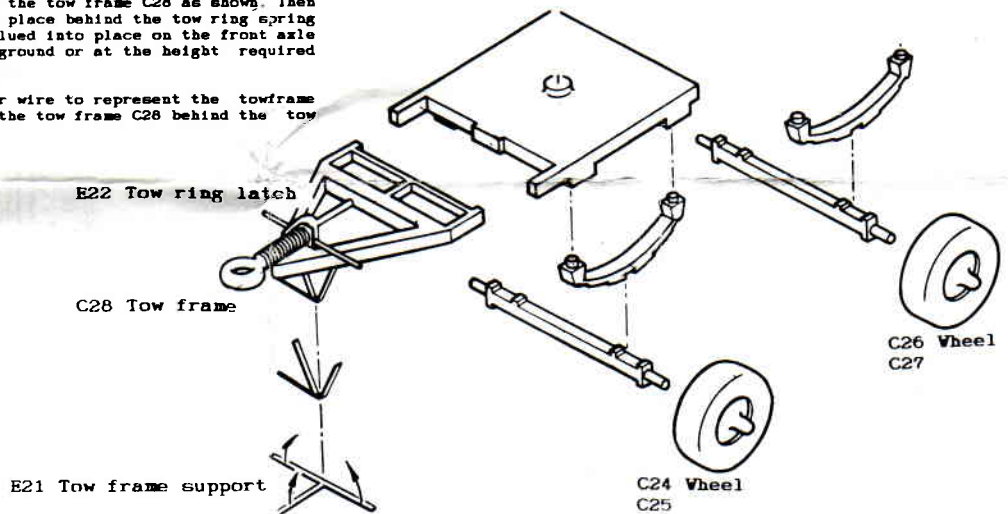

**6 Power Cables**

- a) The power cables are made from the wire included in the kit. The AC cable is a single strand of thicker wire, cut to length. The plug C29 can then be glued into place, and either folded and stowed in the left bin, or bent to rest on the ground to the aircraft socket. See the illustrations for details of various locations for different aircraft types.
- b) For the DC cable, use the thinner wire to simulate the multi-core cable; loop the wire and then twist a number of times to form a single strand. Smaller lengths of this wire can be knotted around the cable to represent the ties, approximately every 25mm along the cable. Give the plug C30 onto the cable, then fix into place as for the AC cable.
- c) Then fit the bin lids in position either open or closed as appropriate.
- d) Paint the exhaust silencer C3 and then glue into place under the chassis as shown.

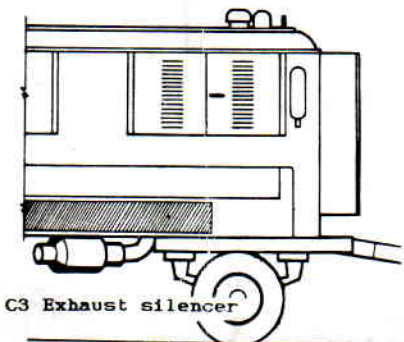
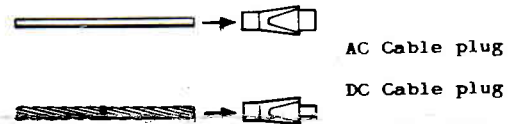

C3 Exhaust silencer

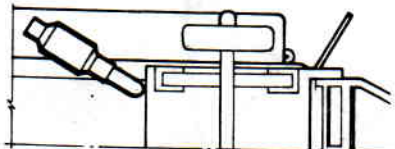

Position of exhaust silencer/muffler

