



Британський учбовий літак

Hunting Provost T.1

CAT.No.72-028
SCALE 1/72

basic trainer aircraft

The Percival P.56 Provost was a British ab initio trainer that was developed for the Royal Air Force in the 1950s as a replacement for the Percival Prentice. It was a low-wing, monoplane with a fixed, tailwheel undercarriage and had an unusual side-by-side seating arrangement. The Provost has the distinction of being the last piston-engine basic trainer aircraft to be operated by the RAF.

The Provost was later adapted to make use of a turbojet engine, producing the BAC Jet Provost. The type was withdrawn in the 1960s, in favour of its jet-powered successor.

Part of the model

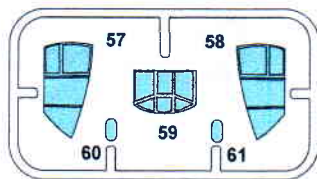
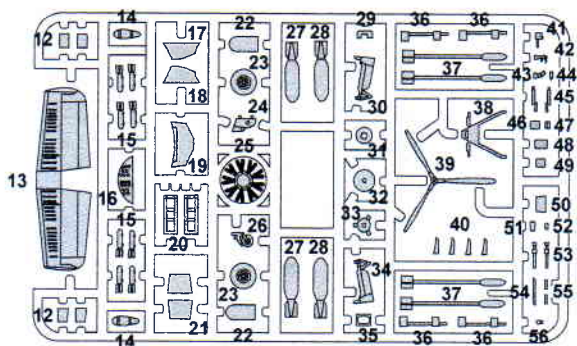
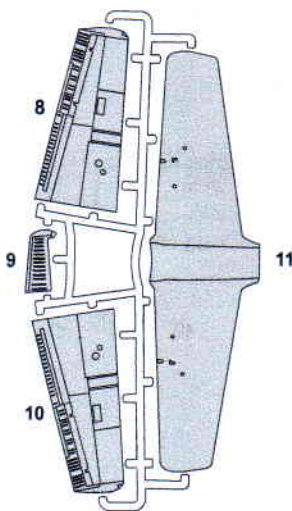
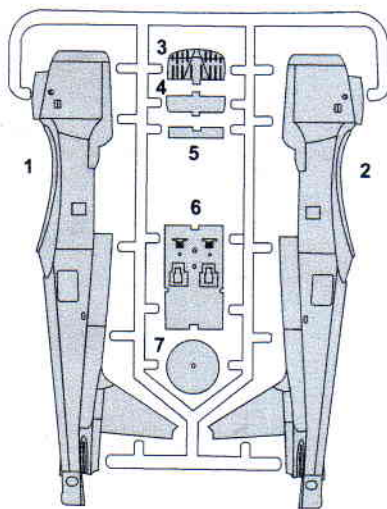

①



③

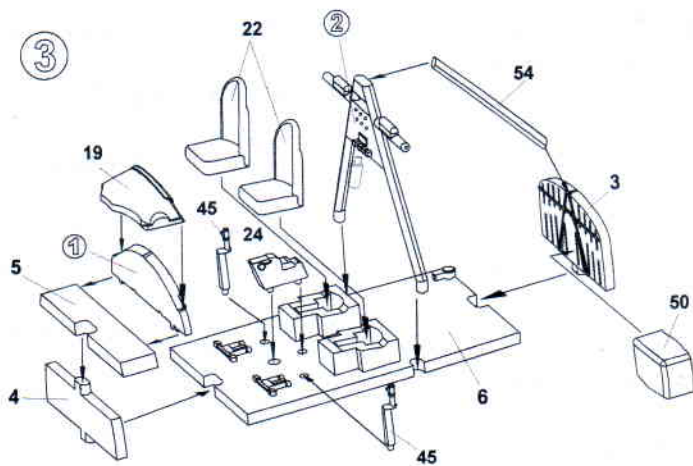

②



④

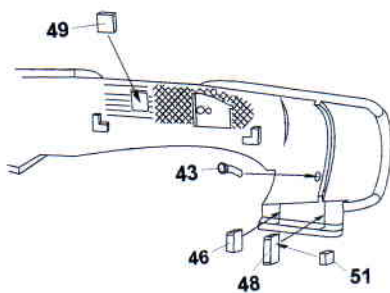

⑤

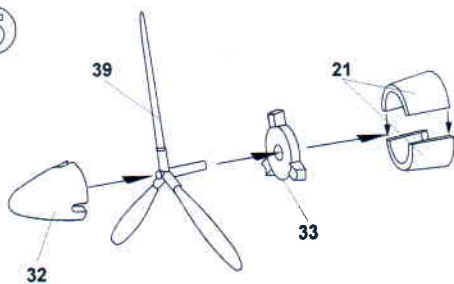

⑥

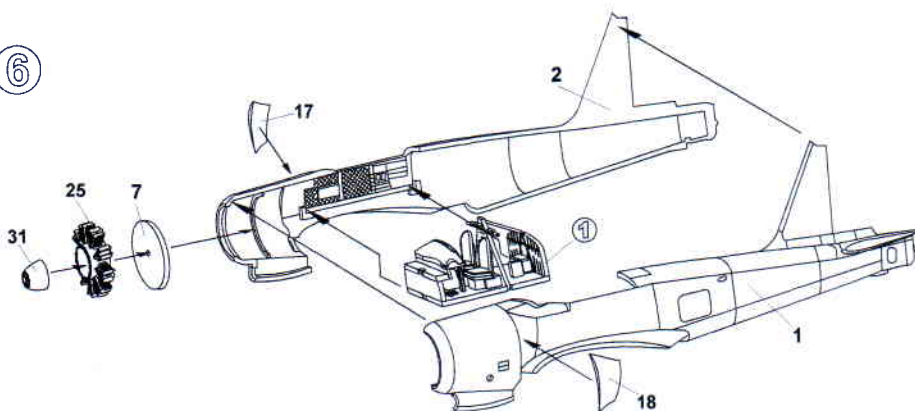

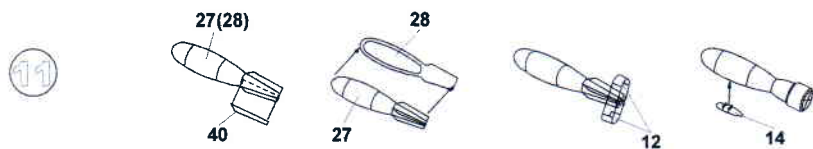
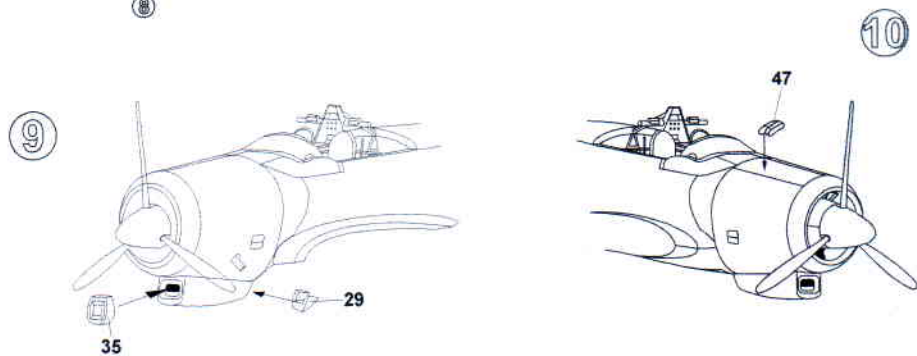
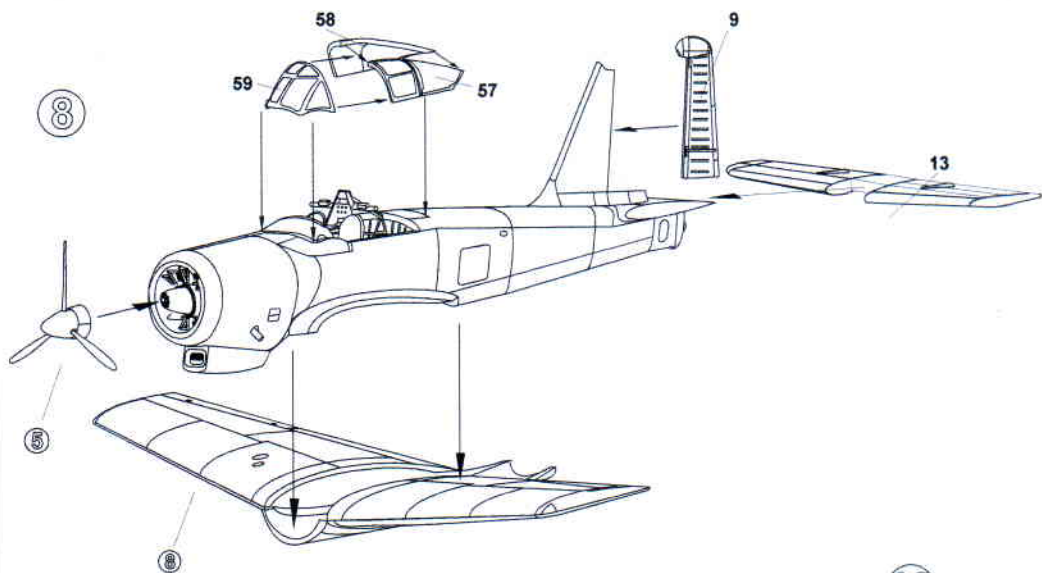
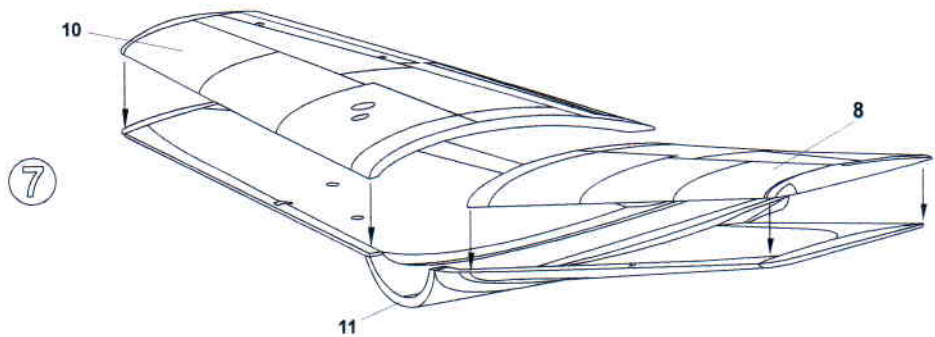

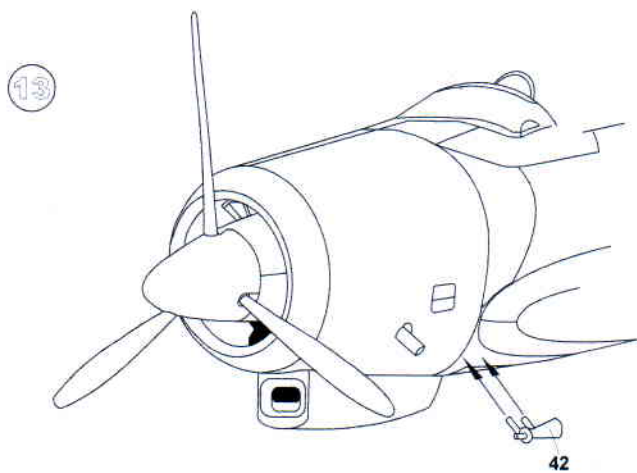
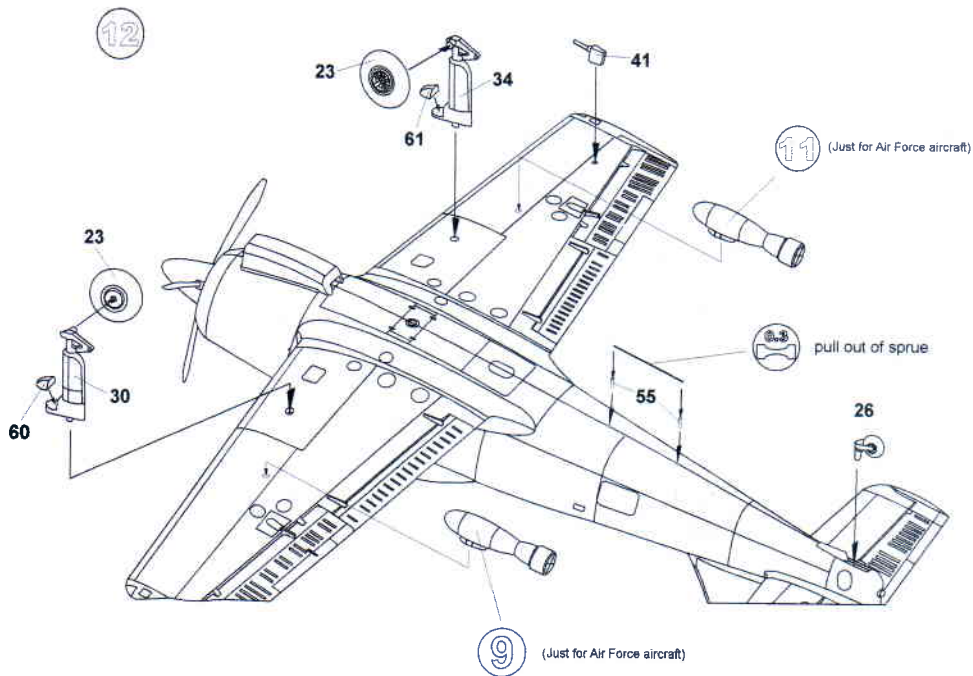

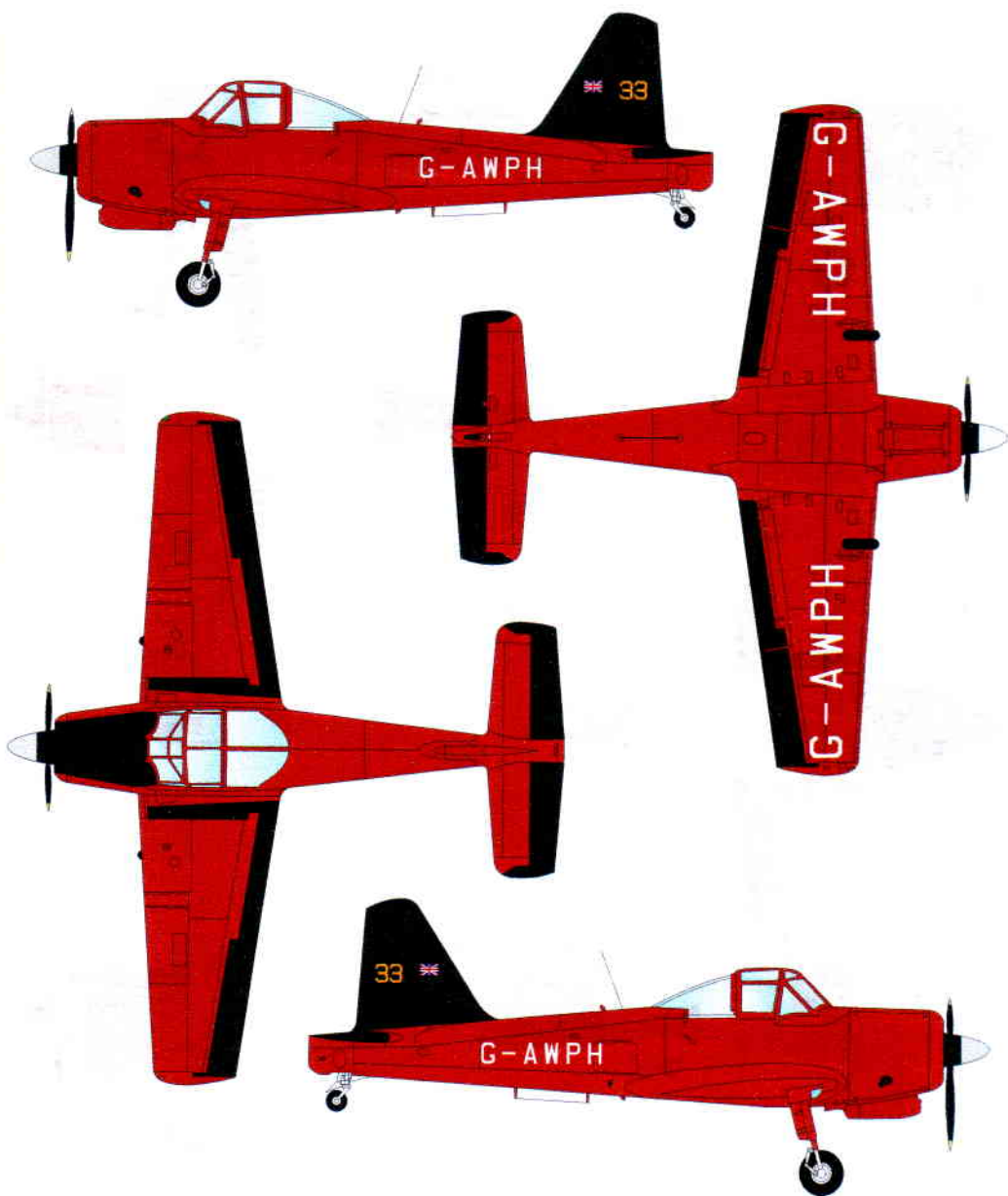

Hunting Provost T.1

G-AWPH, "33", Privately owned in the Three Mile Cross area, Wokingham, UK, 2004.

Overall Bright Gloss Red with Gloss Black anti-glare tail unit, tailerons, ailerons and flaps. Silver and Gloss Black spinner with Matt Black wing walkways.

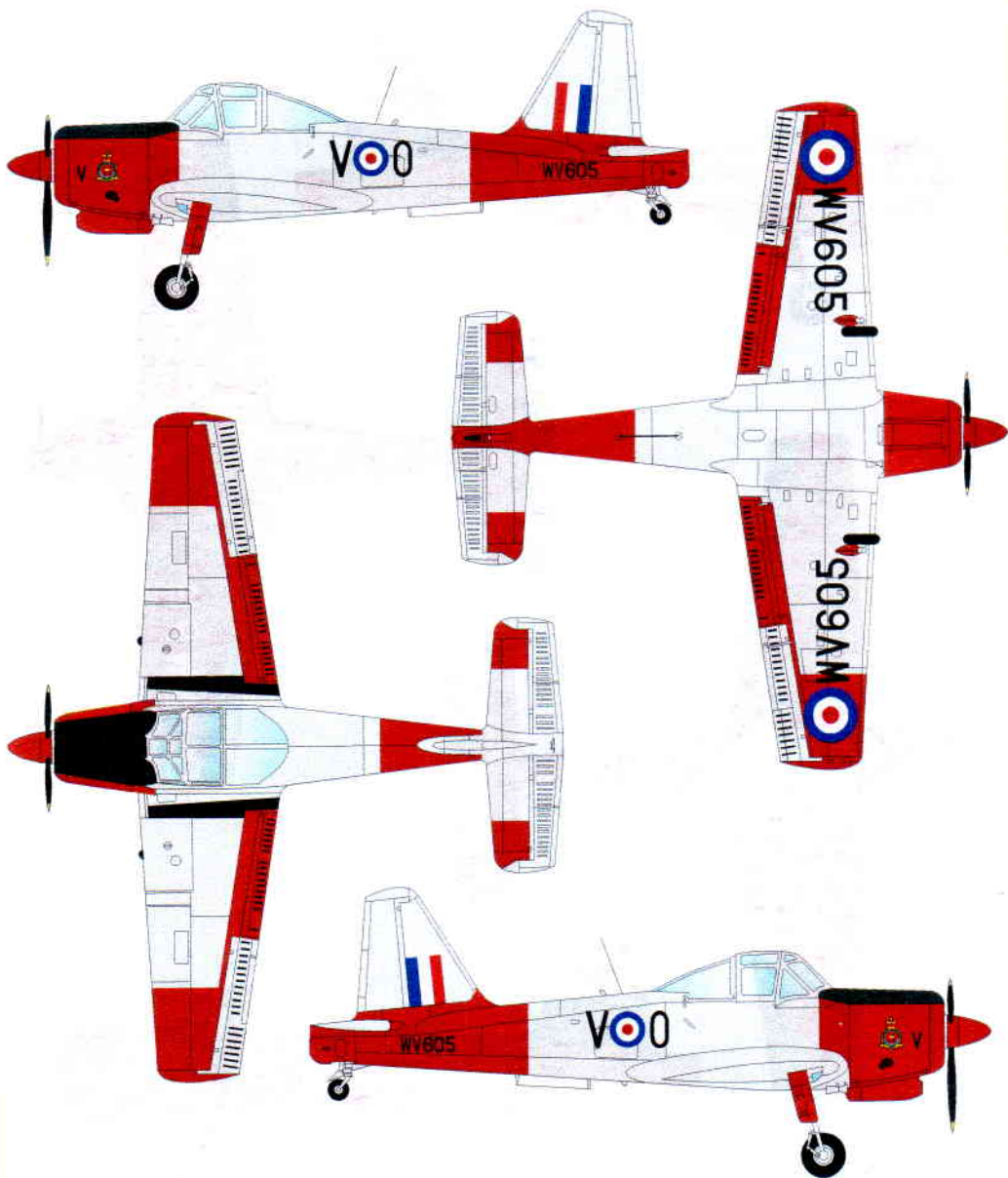

Hunting Provost T.1

Wv605, "V.O" of 6 Squadron, Royal Air Force, RAF Wattisham, 17 September, 1960.

Overall High Speed Silver with Matt Black anti-glare panel and large areas of Fluorescent Red/Orange on rear fuselage, tailplanes, cowling and wing upper and lower surfaces. Fluorescent Red/Orange spinner, Matt Black wing walkways and Identification Red undercarriage legs.

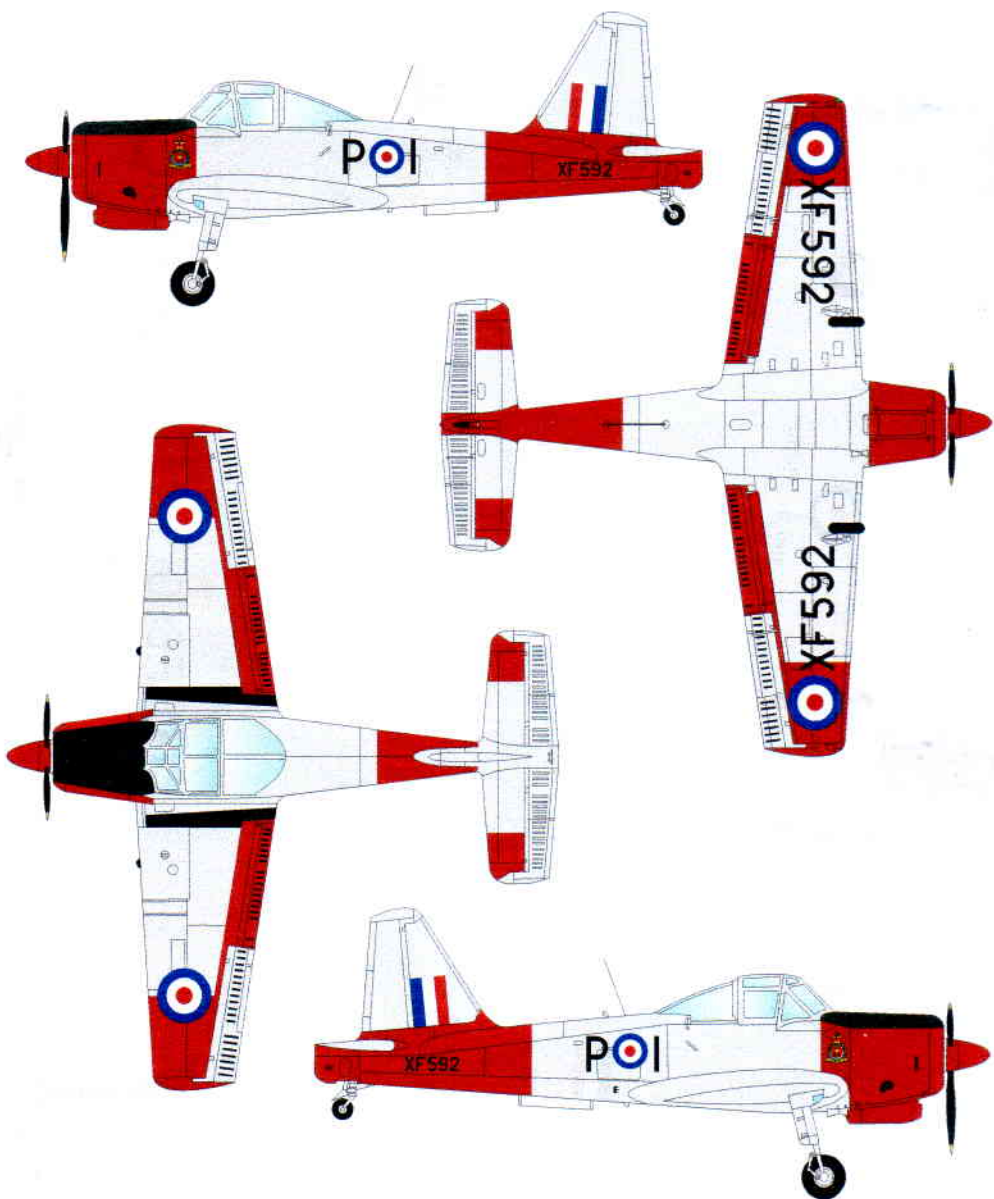

Hunting Provost T.1

XF592, "P.I." of No.1 Flying Training School, Royal Air Force, RAF Linton-on-Ouse, 1960.

Overall High Speed Silver with Matt Black anti-glare panel and large areas of Fluorescent Red/Orange on rear fuselage, tailplanes, cowling and wing upper and lower surfaces. Fluorescent Red/Orange spinner and Matt Black wing walkways.

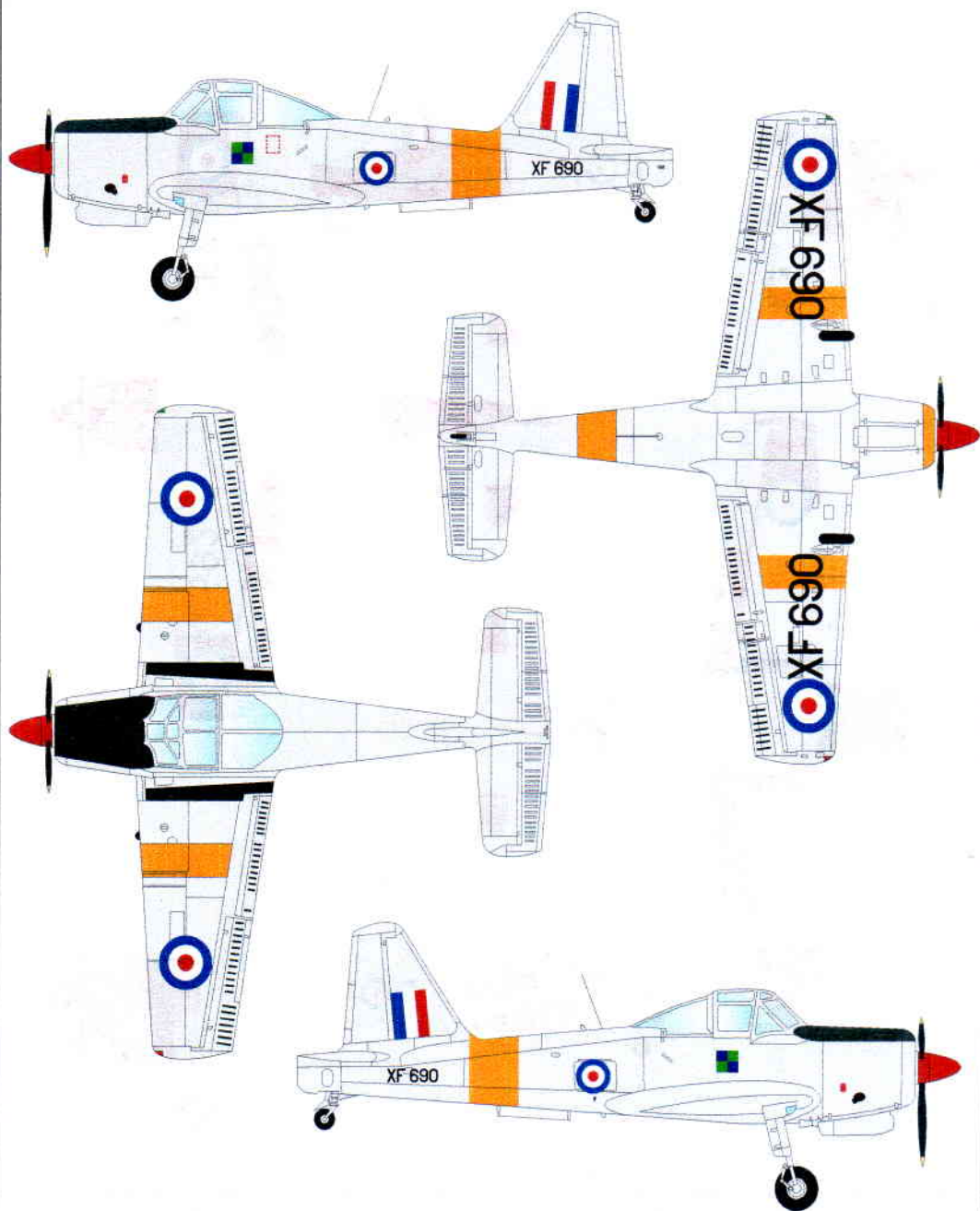

Hunting Provost T.1

Xf690, finished in typical early post war training colours, circa 1990's

Overall High Speed Silver with Matt Black anti-glare panel and Identification Yellow bands around the wings and rear fuselage.
Matt Black wing walkways and a Gloss Identification Red spinner.