

## Dornier Do 27/CASA C-127

### German, Spanish and Belgian Service

#### NÁVOD / INSTRUCTIONS

##### CZ – Historie

Dr Claudius Dornier ml. odešel po druhé světové válce, podobně jako jiní němečtí konstruktéři do zahraničí. Obával se zákazu stavby letadel. Založil ve Španělsku továrnu OTEDA (Oficinas Técnicas Dornier). Zde zkonstruoval v polovině padesátých let na objednávku španělského ministerstva letectví čtyřmístný celokovový hornoplošník s vlastnostmi STOL označený Dornier Do 25. Dva prototypy byly postaveny továrnou CASA. První prototyp byl poháněn motorem Elizalde Tigre G-IV-B, druhý Continentalem O-470-J. Oba motory se ale ukázaly slabé. V rekonstruované továrně Dornier v Německu vznikl na základě Do 25 nový prototyp Dornier Do 27 s motorem Lycoming GSO-480-B1B6. Dornier Do 27 byl přijat do sériové výroby a stal se prvním velkosériově vyráběným letadlem v Německu po druhé světové válce. Celkově bylo vyrobeno 428 ks letadel, které odebíraly postupně v několika verzích tři složky nově budovaných německých ozbrojených sil, letectvo, námořnictvo i pozemní síly. Zároveň se ve Španělsku rozeběhla výroba padesátikusové série pro španělské letectvo s označením CASA C-127/U.9. Dornier Do 27 byl vyráběn v několika verzích lišících se podvozkem, typem motoru a použitím vrtule, dvojím nebo jednoduchým řízením a tvarem svislé ocasní plochy. Do 27 byl dodáván mnoha evropským ozbrojeným silám (např. Portugalsko, Belgie, Švédsko, Švýcarsko), létal ale i jinde ve světě. Kromě několika afrických zemí i v Brazílii, státu Izrael a Turecku. Mimo vojenských sil se Do 27 dočkaly širokého uplatnění u civilních uživatelů. Letouny byly s oblibou používány „bush piloty“ v drsných podmínkách nepravidelné dopravy v Africe a Jižní Americe. V Evropě byly používány jako turistické a k vysazování parašutistů. Nejslavnějším civilním Do 27 byl patrně „zebrí stroj“ Bernharda Grzimeka použitý při filmování zvěře v Africe. Některé civilní stroje létají dodnes.

Rozpětí: 12,0 m, délka: 9,6 m, max. rychlost: 210 km/h, dolet 1 350 km, dostup: 5 000 m.

##### EN – History

In the post war year, many German aircraft designers feared the possible ban on aircraft production and begun to leave the country. Among them also Claudius Dornier Jr., the son of the famous German WW2 aircraft builder. He settled in Spain where he founded company named Oficinas Técnicas Dornier (OTEDO). In the middle 50's, the Spanish Air Ministry was looking for a new STOL aircraft and having received the order, Dornier designed the Dornier Do 25 type, a high wing aircraft for a crew of four. Two prototype airframes were built by CASA company in Spain, while in Germany, in rebuilt Dornier works, the type was redesigned to the Do 27, powered by the Lycoming GSO-480-B1B6 engine. This type was also finally put into production, becoming the first aircraft to be mass-produced in Germany after the war. In total, 428 airframes were built in several different versions and they were operated by all three services of the newly built German military, ie. the air force, navy and land forces. At the same time, a 50-unit batch was also produced in Spain for their military, named the CASA C-127/U.9. The type's many versions differed mainly by the style of the undercarriage, engine and propeller used, the shape of the tail fin or by having either single or twin controls in the cockpit. The Dornier Do 27 was not only used by air forces of many European countries, namely by Portugal, Belgium, Sweden, Switzerland and some others, but also elsewhere over the globe. It could be seen flying in several African countries, in the State of Israel and also in Turkey. The type found its way to civil aviation market too and was quite liked by so-called bush pilots for its excellent performance in harsh conditions of irregular transport lines in Africa or South America. In Europe, the Do 27 served as touring or skydiving aircraft.

Wingspan: 12.0 m, Length: 9.6 m, Max. Speed 210 kmh, Range: 1,350 km, Ceiling: 5,000 m.

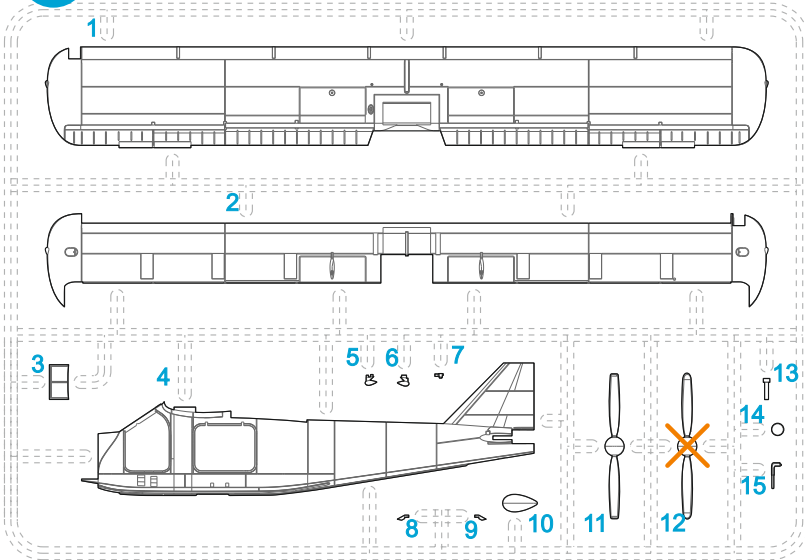
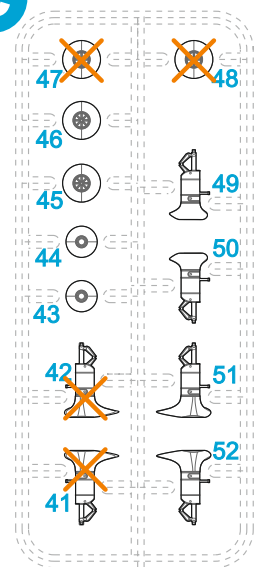
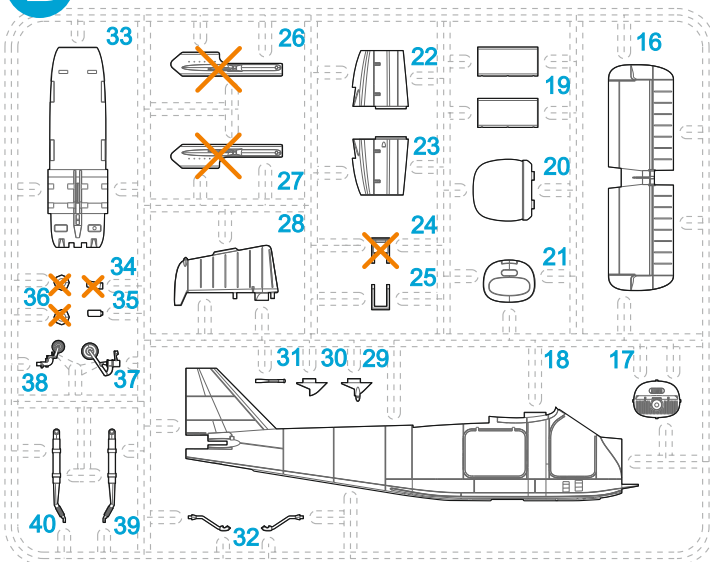
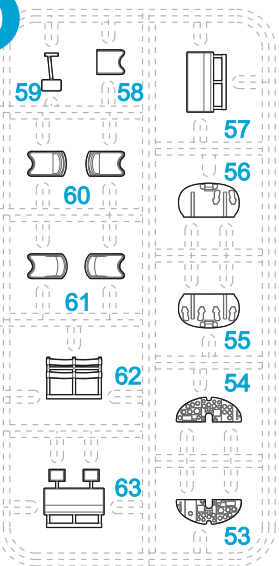
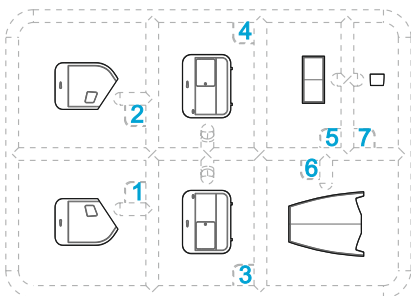
**A****C****B****D****CLEAR PARTS (CP)****PHOTO-ETCHED PARTS (PP)**

 Tento díl nepoužít.  
Do not use this part.

**Barvy GUNZE/ GUNZE Colour No.**

<b>A</b>	Černá / Black	H12/C33
<b>B</b>	Šedá / Gray	H325/C325
<b>C</b>	Hliník / Aluminium	H8/C8
<b>D</b>	Hnědočervená / Leather	H47/C41
<b>E</b>	Dřevo / Wood Brown	H37/C43
<b>F</b>	Plátno / Linen (Tan)	H27/C44
<b>G</b>	Červená / Red	H3/C3
<b>H</b>	Opálený kov / Burnt Iron	H76/C61
<b>I</b>	Barva pneu / Tire Black	H77/C137
<b>J</b>	Červená čirá / Clear Red	H90/C47
<b>K</b>	Zelená čirá / Clear Green	H94/C138
<b>L</b>	Chrom. stříbrná / Chrome Silver	MC211
<b>M</b>	Bílá / White	H1/C1

**SYMBOLS**

MOŽNOST VOLBY  
OPTIONAL  
NACH BELIEBEN  
OPTION



POUŽÍT KYANOAKRYLÁTOVÉ LEPIDLO  
INSTANT CYANOACRYLATE GLUE  
ZYANOAKRYLÁTKLEBER  
ADHÉSIF CYANOACRYLAT



OHNOUT  
BEND  
BIEGEN  
COURBER



ZHOTOVIT NOVĚ  
SCRATCH BUILD  
FERTIGSTELLEN  
ACHEVER



ŘEZAT/VRTAT  
CUT OFF/DRILL  
ENTFERNEN  
DETACHER



NATRÍT  
COLOUR  
FARBEN  
PEINDRE

**1**  
camo A/C only

# CAMO A/C ONLY

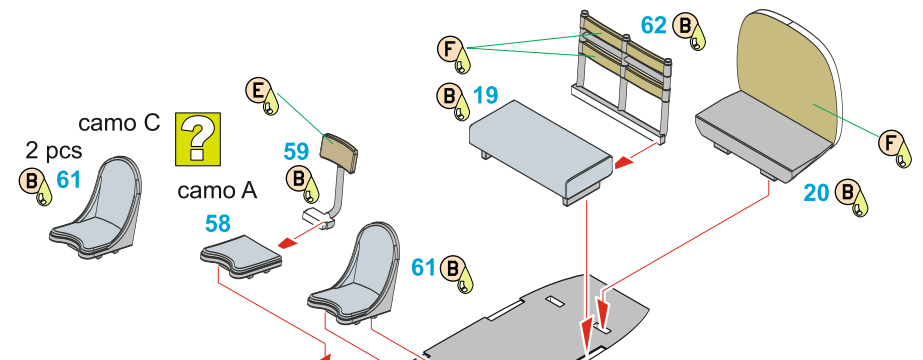

**2**  
camo A/C only

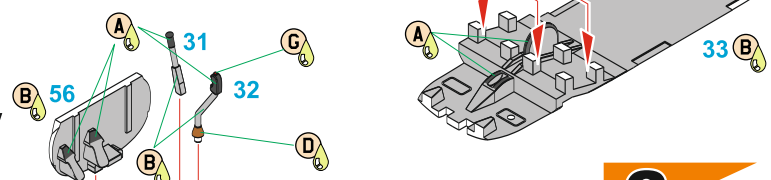

**3**  
camo A/C only

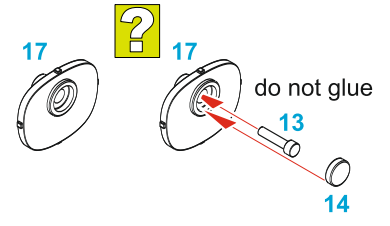

**4**  
camo A/C only

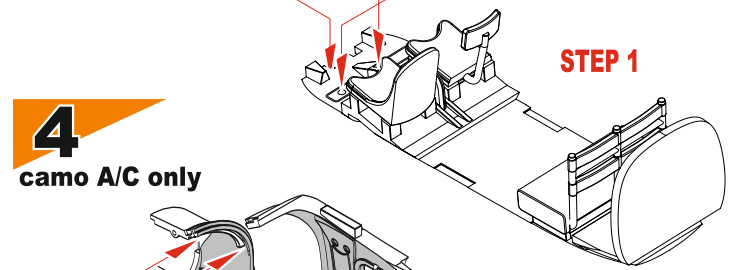

**5**  
camo A/C only

both fuselage halves

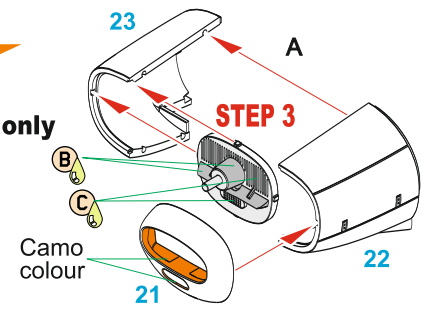

Decal 52

camo B only  
both fuselage halves

camo A only  
both fuselage halves

**6**  
camo A/C only

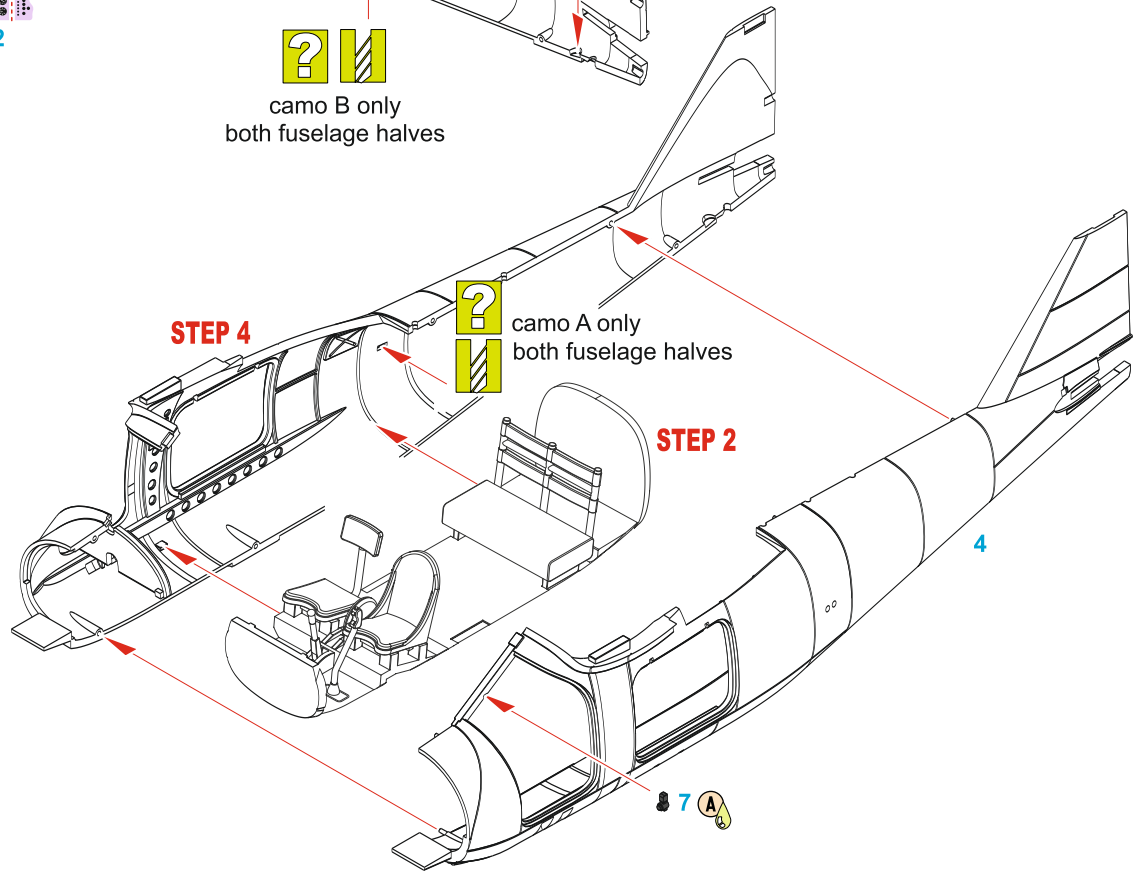

**1**  
camo B only

# CAMO B ONLY

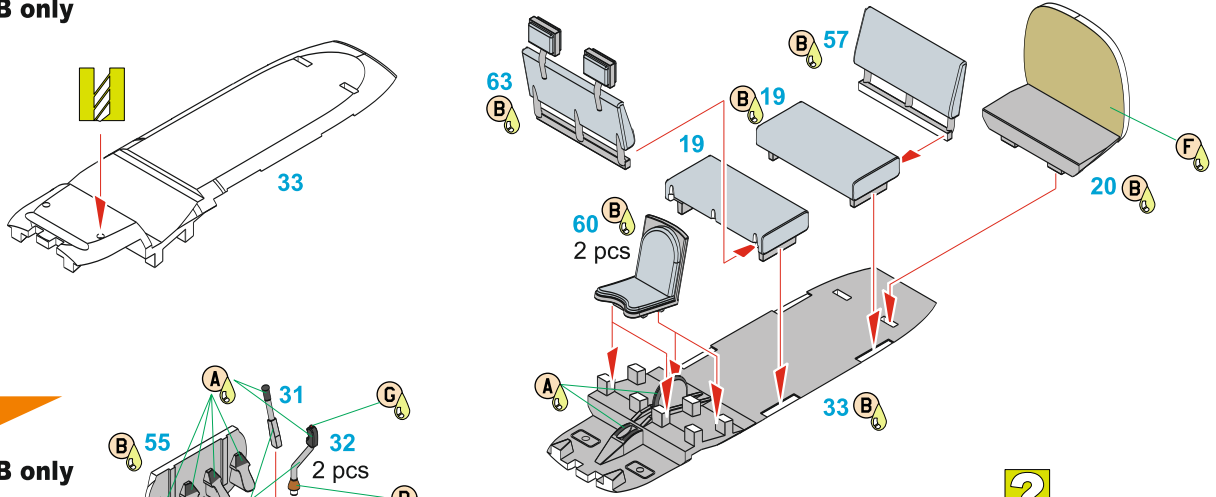

**2**  
camo B only

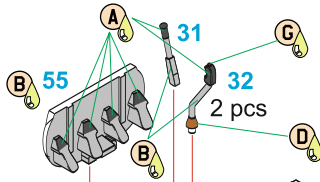

**3**  
camo B only

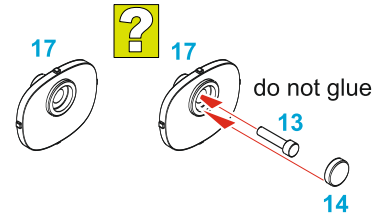

**4**  
camo B only

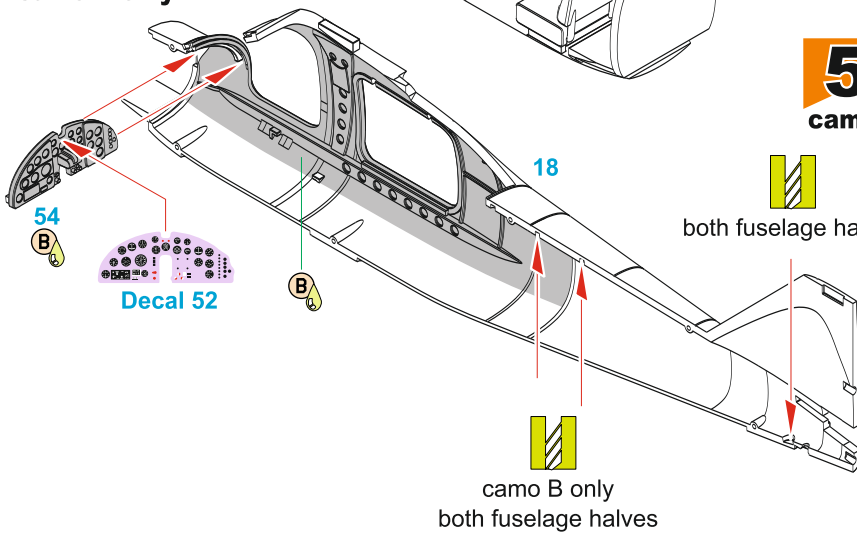

**5**  
camo B only

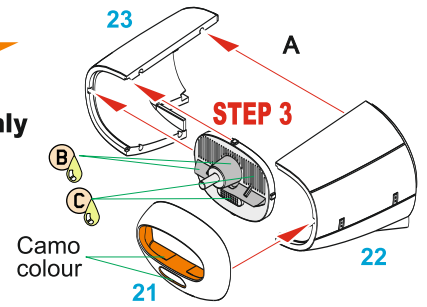

**6**  
camo B only

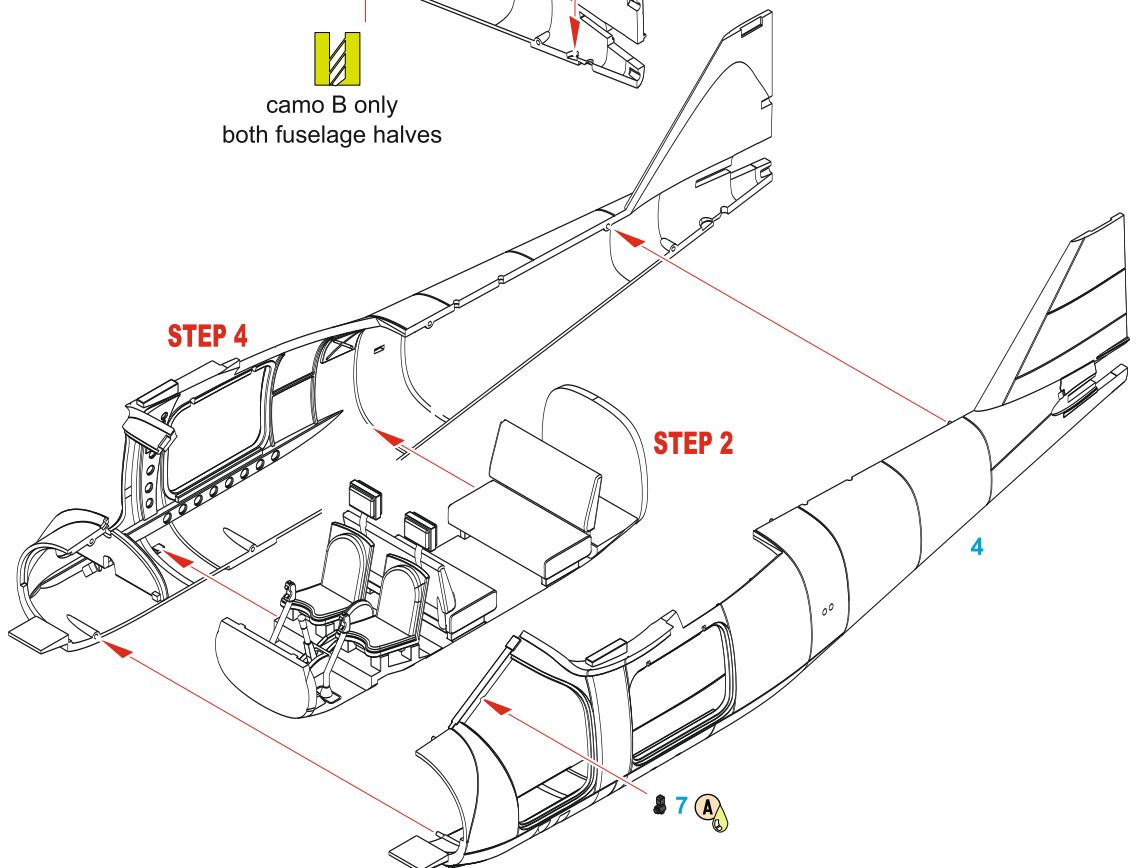



# 7

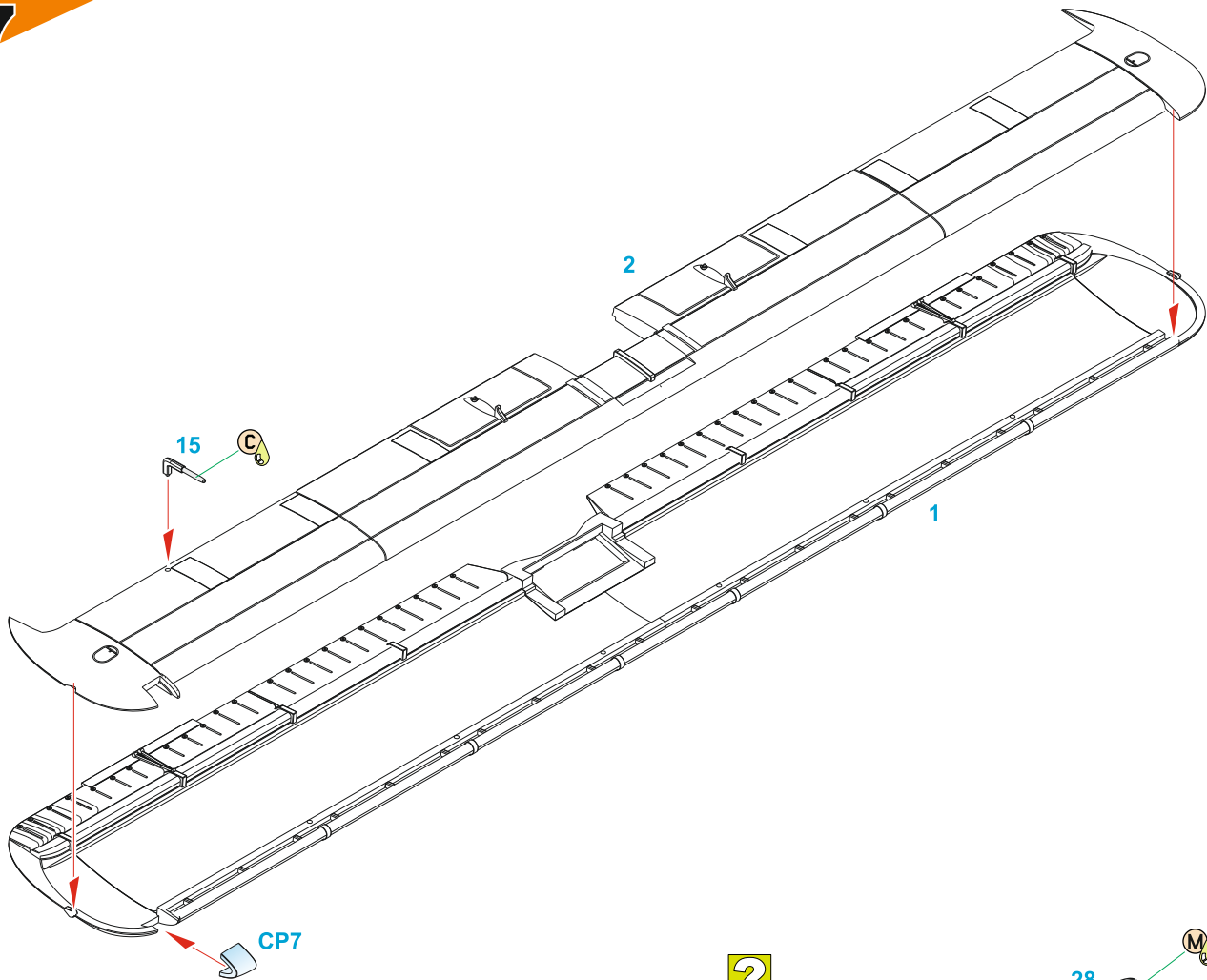

# 8

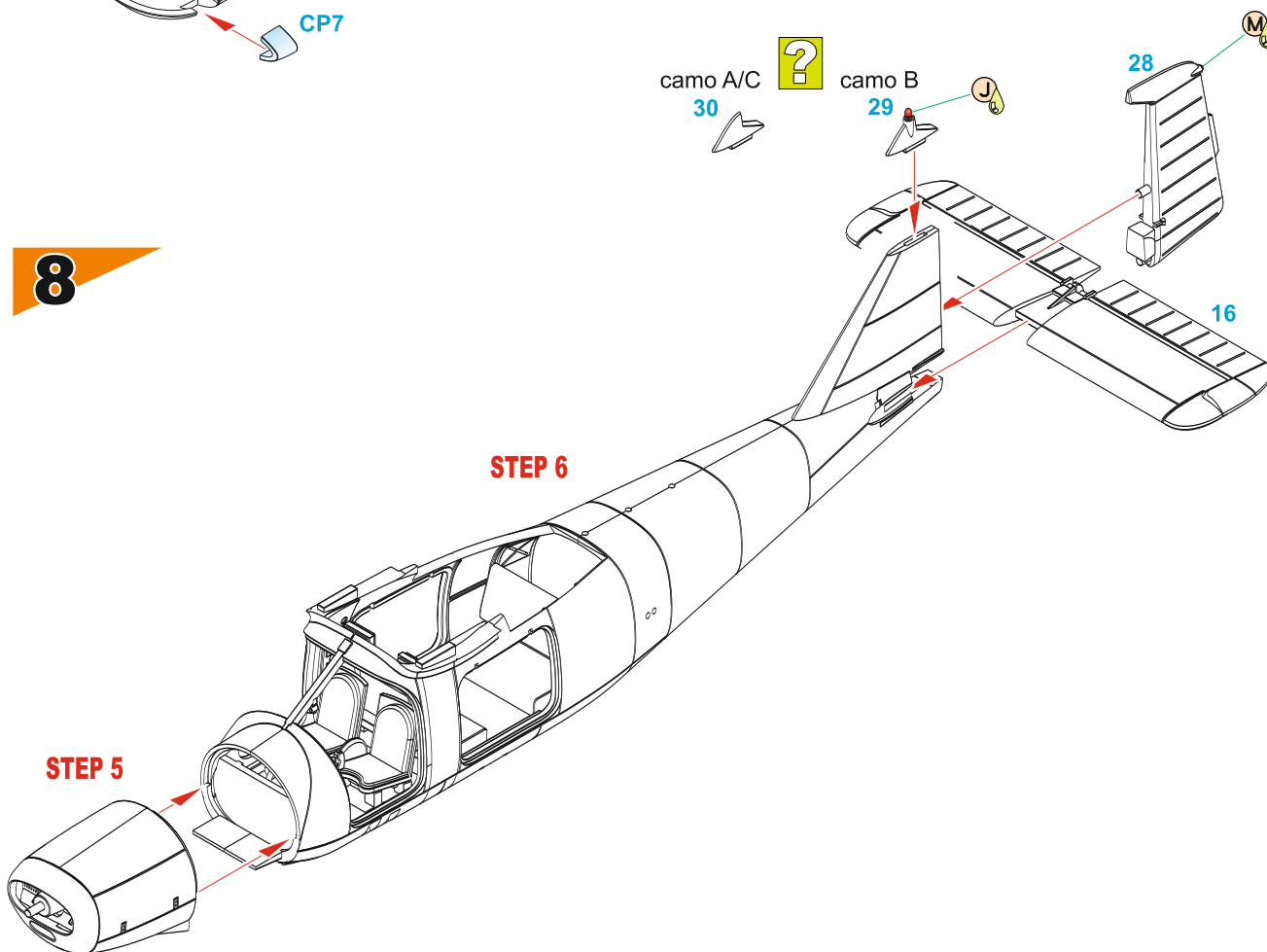

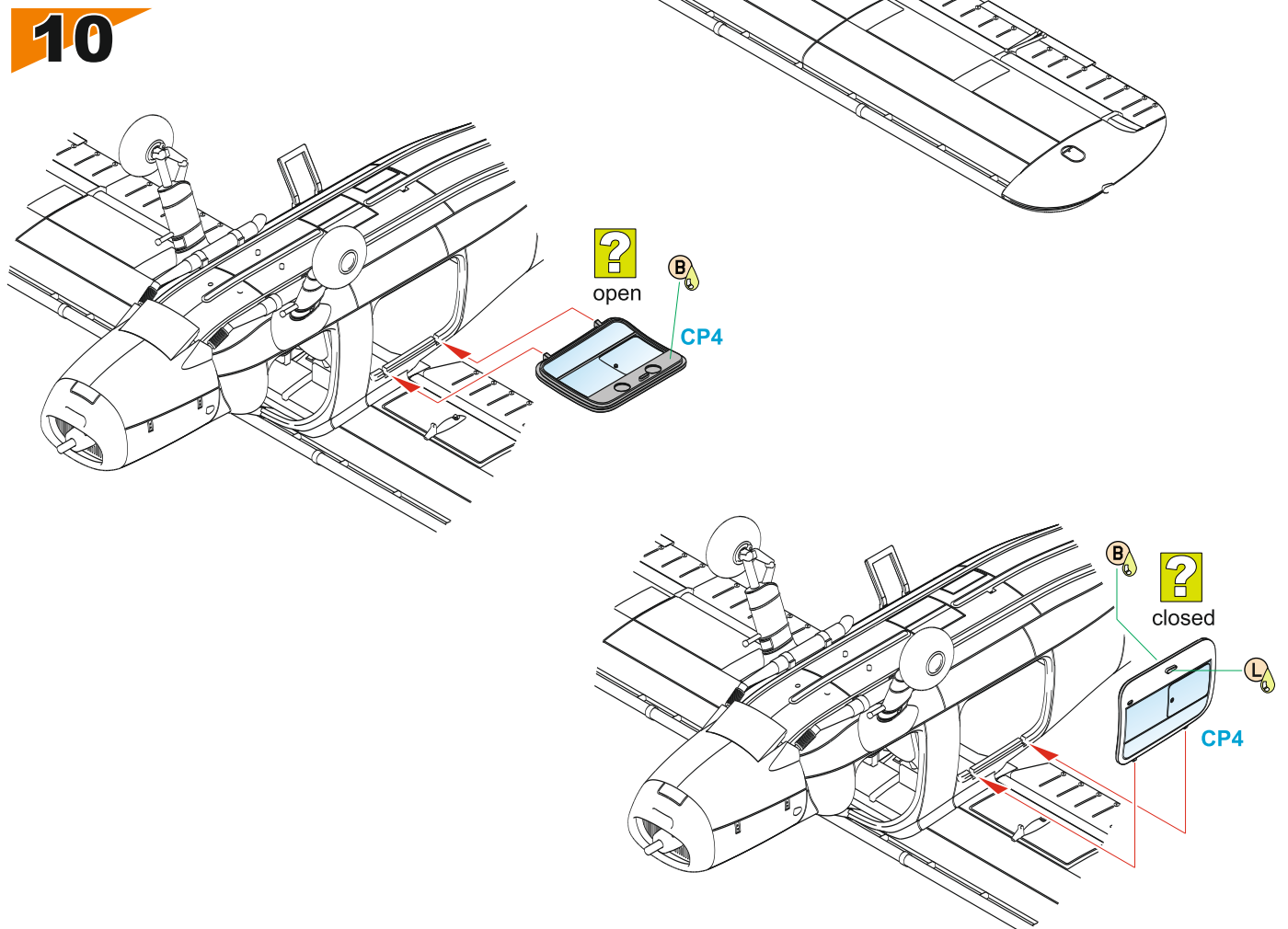
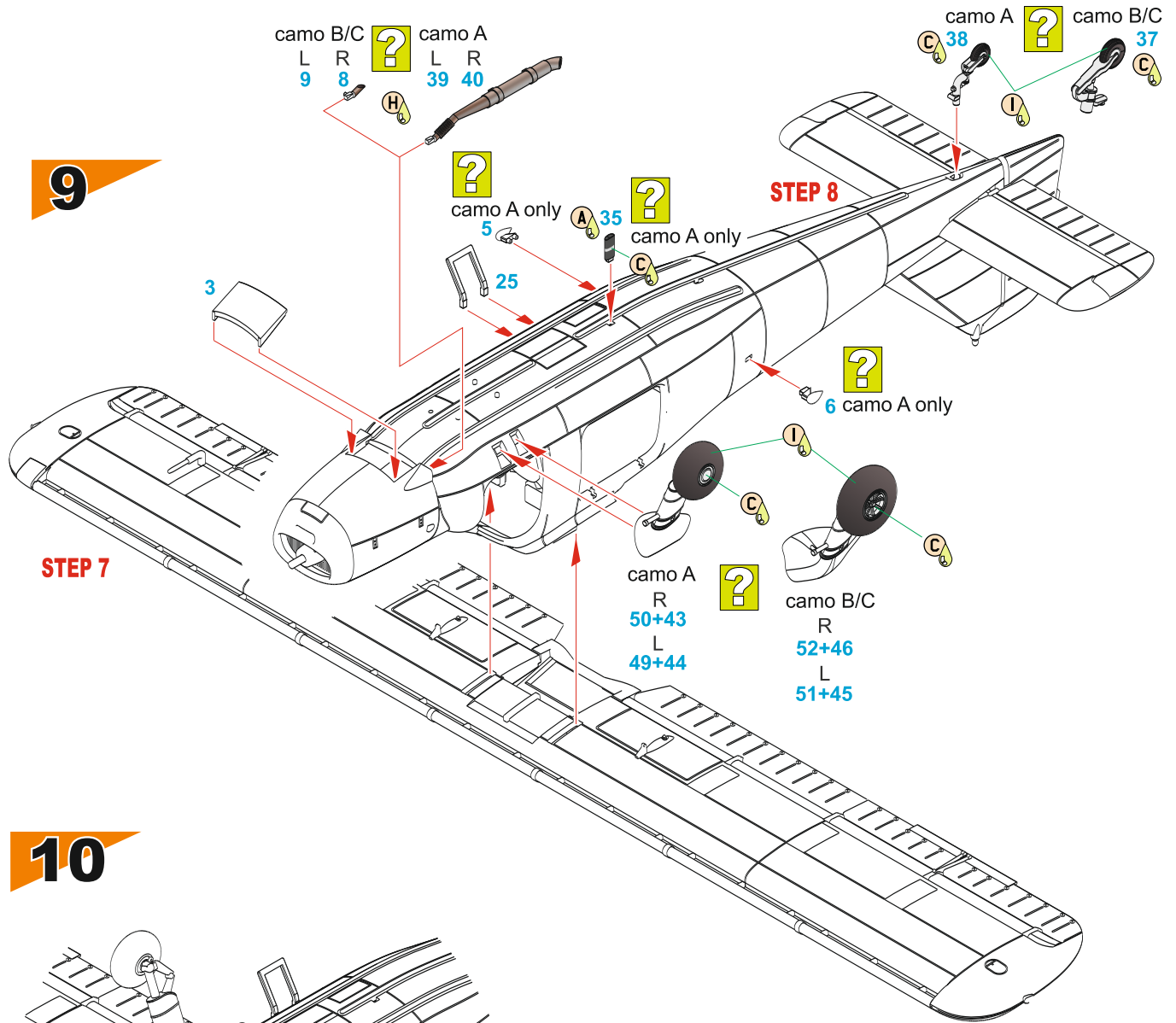



Dornier Do 27A-1, WNr.232, 55+84, WaSLw 30, Bundesluftwaffe, základna Penzing, 1977.

Dornier Do 27A-1, WNr.232, 55+84, WaSLw 30, German Air Force (Bundesluftwaffe), Penzing AB, 1977.

# CAM. A

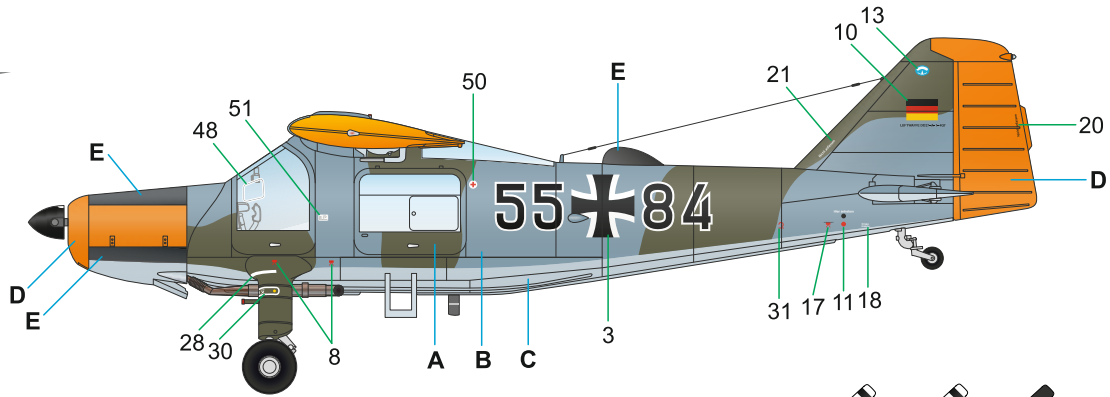

Fotografie dokládají, že kužel byl na vrtuli instalován oběma způsoby.  
Photos show spinner attached to propeller both ways.

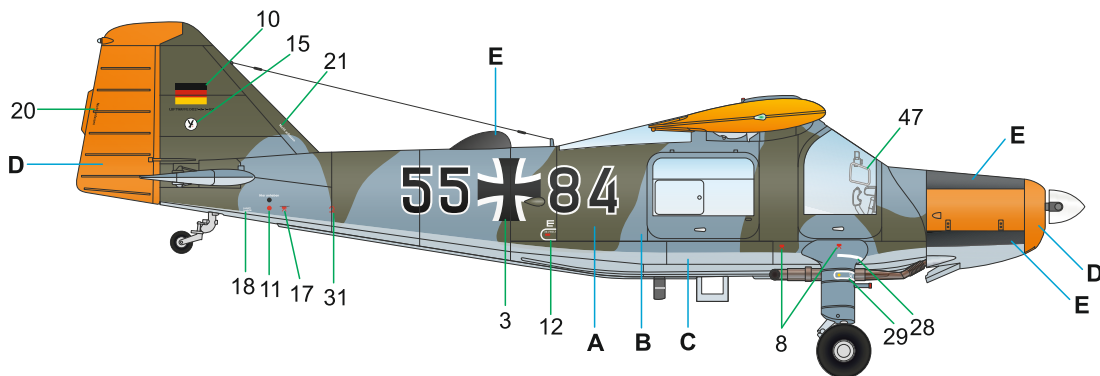
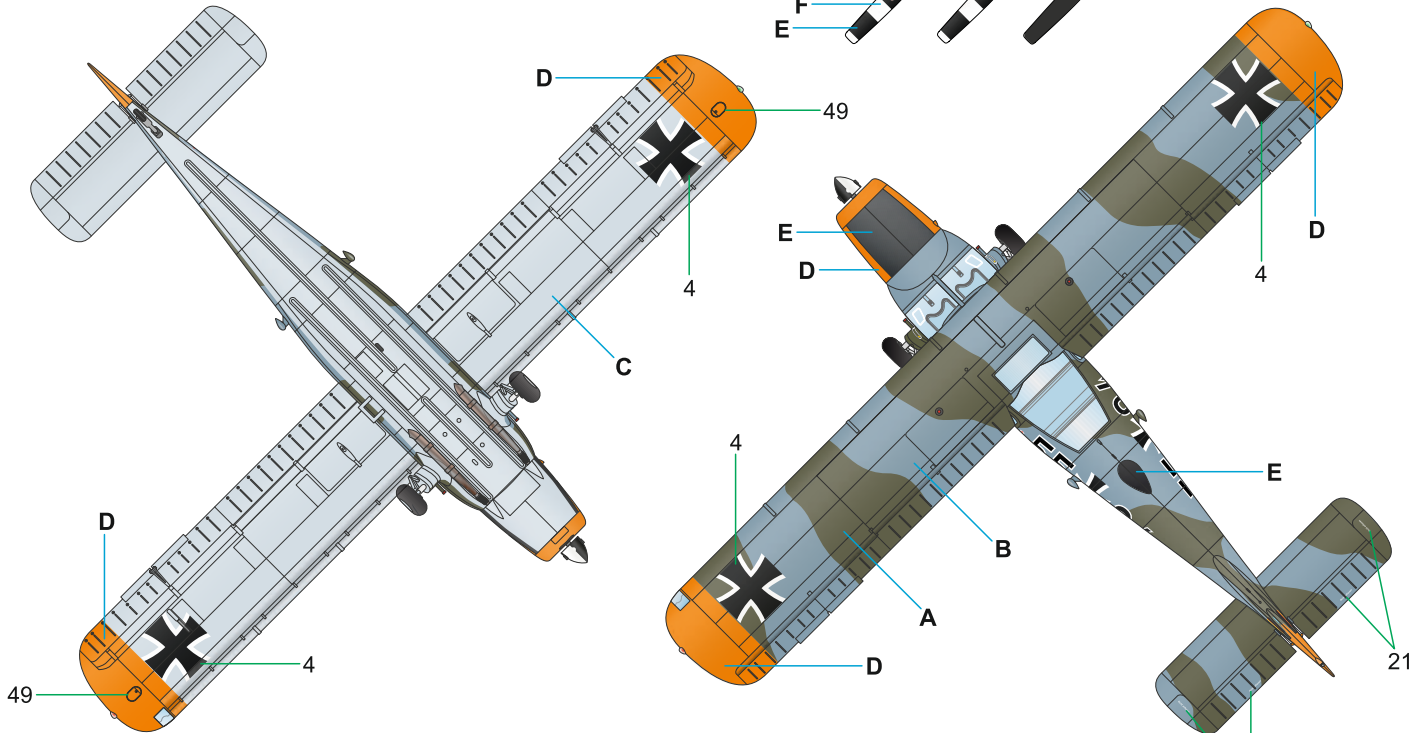
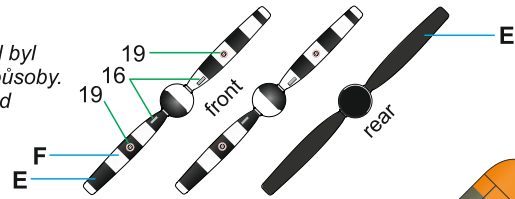

Special HOBBY

GUNZE SANGYO

- |   |   |   |  |                                      |                                     |
|---|---|---|--|--------------------------------------|-------------------------------------|
| <b>A</b> Olivově žlutá<br>Olive Yellow<br>Gelboliv<br>H340/C340 | <b>B</b> Stř. šedivá<br>Grey<br>Basaltgrau<br>H301/C301 | <b>C</b> Sv. šedivá<br>Lt. Grey<br>Graualuminium<br>H315/C315 | <b>D</b> Dayglo oranžová<br>Dayglo Orange<br>Leuchtorange<br>H098/C098 | <b>E</b> Černá<br>Black<br>H012/C033 | <b>F</b> Bílá<br>White<br>H011/C062 |
|---|---|---|--|--------------------------------------|-------------------------------------|



Dornier Do.27J-1, OL-D11 (OT-AMJ), jeden ze dvanácti spojovacích Do.27 Belgického letectva, sedemdesátá léta minulého století. Stroj byl po vyřazení z Belgického letectva a revizi u firmy Dornier prodán vojenskému letectvu státu Malawi. Přes Velkou Británii byl posléze prodán do Ecuadoru.

Dornier Do.27J-1, OL-D11 (OT-AMJ), one of a total of twelve communications Do.27s that saw service with the Belgian Army Light Aviation (Aviation Legere de la Force Terrestre Belge), 1970s. Written from use and overhauled at Dornier, it was sold to the Malawi Army Air Wing. Even later sold, via the UK, to Ecuador.

## CAM. B

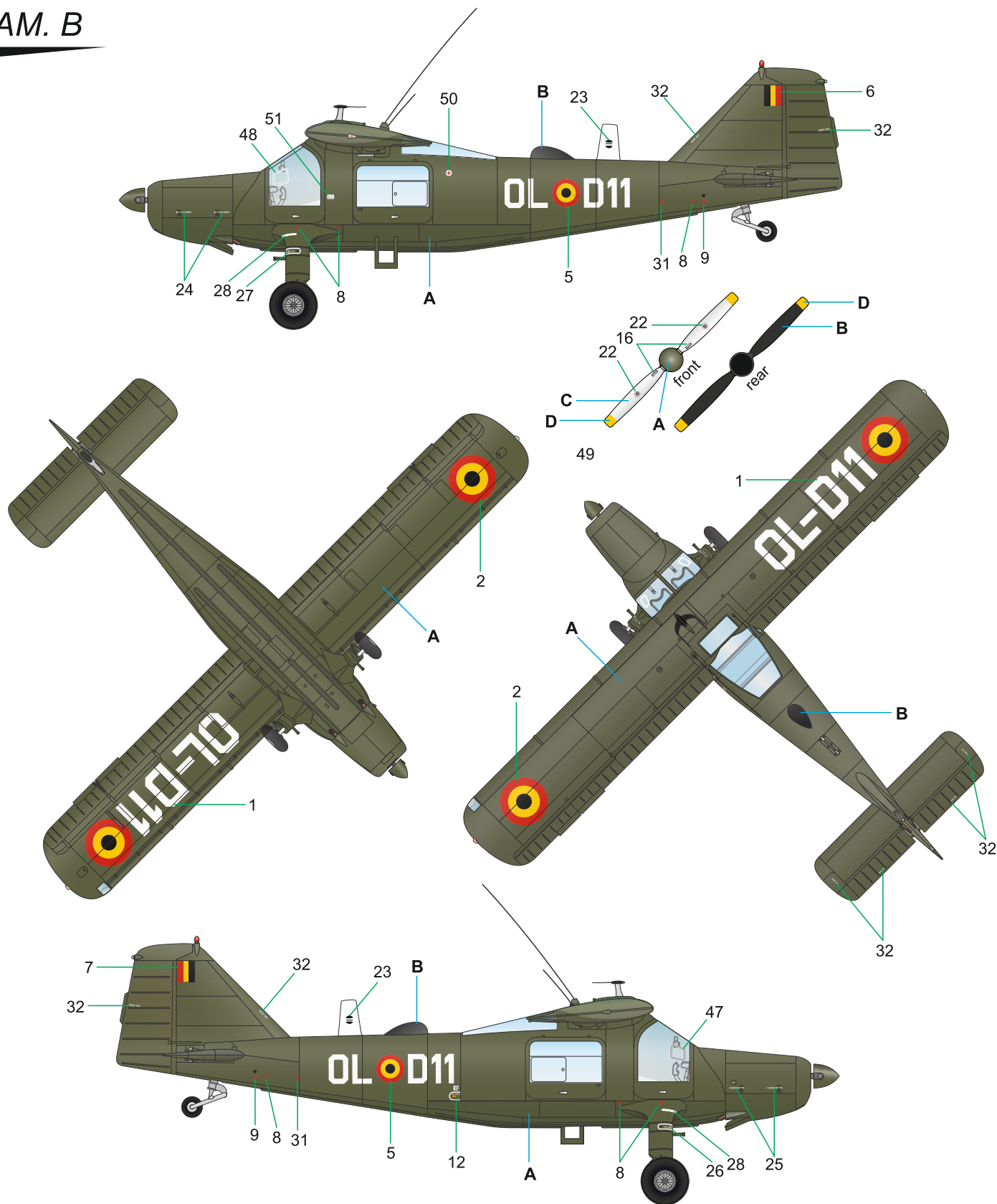

**A** Olivově zelená  
Olive Green  
Olivgrün  
H420/C120

**B** Černá  
Black  
H012/C033

**C** Stříbrná  
Silver  
H008/C008

**D** Žlutá  
Yellow  
H329 / C329

Special  
**HOBBY**  
GUNZE  
SANGYO

CASA C 127, L9-4/408-1, Al-Ajún (El Aaiun),  
Španělská Sahara, Španělské letectvo, 1970.

CASA C 127, L9-4/408-1, Laayoune (El Aaiun),  
Spanish Sahara, Spanish Air Force (Ejército del Aire),  
1970.

## CAM. C

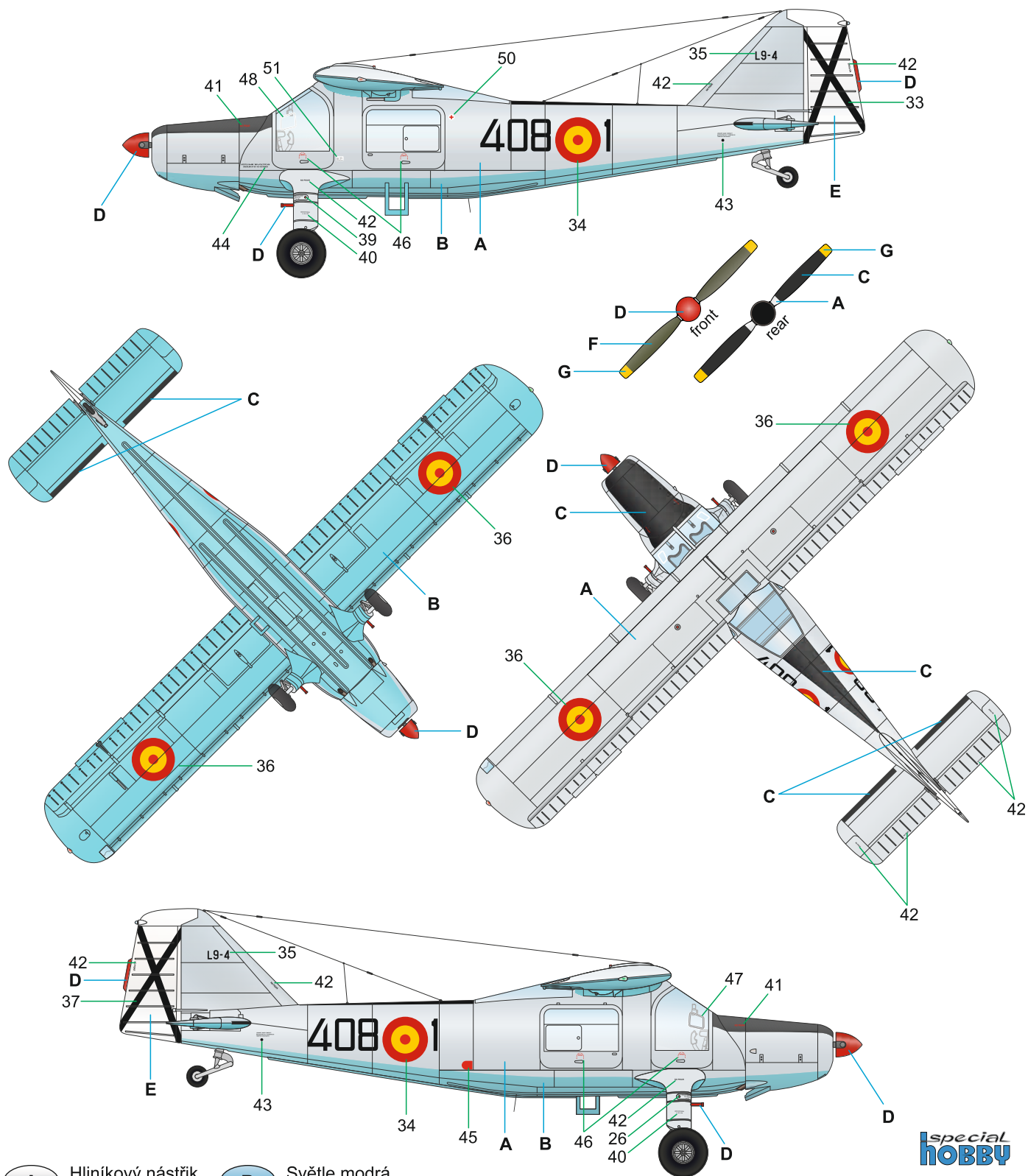

**A** Hliníkový nástřik  
Aluminium paint  
H8+11/C8+62

**B** Světle modrá  
Light Blue  
H323/C323

**C** Černá  
Black  
H12/C33

**D** Červená  
Red  
H3/C3

**E** Bílá  
White  
H11/C62

**F** Olivová  
Olive Drab  
H304/C318

**G** Žlutá  
Yellow  
H329/C329

Special  
**HOBBY**  
GUNZE  
SANGYO

# ATTRACTIVE 1/72 SCALE MODELS OFFERED BY **Special HOBBY**



## USE CMK TOOLS AND WEATHERING PIGMENTS FOR YOUR KITS

H1010 handle for our saws  
– priceless tool for resin  
parts adjustment



H1011 CMK sanding stick  
– four different grit  
of sanding papers on  
one sanding stick



*Star Dust*  
weathering pigments

All of the above items can be found and ordered  
via our official website and e-shop .....

**WWW.SPECIALHOBBY.EU**  
**WWW.CMKKITS.COM**



# ATTRACTIVE 1/72 SCALE MODELS

SH72374 1/72  
**P-40N Warhawk**



SH72377 1/72  
**Kittyhawk Mk.IA**

CMK SETS  
**P-40**  
WARHAWK  
KITTYHAWK  
SPECIAL HOBBY



**Q72293 1/72** P-40E/F/K/L/M and N-1 Seat  
**Q72294 1/72** P-40N-5 through N-40 Seat  
**Q72 299 1/72** P-40E, F, K, L, M and N-1 Seat with Belts



**Q72300 1/72** P-40N-5 through N-40 Seat with Belts  
**Q72 302 1/72** Kittyhawk I, Ia, II, IIa and III Seat with Sutton Harness  
**Q72303 1/72** Kittyhawk IV Seat with Sutton Harness



**Q72295 1/72** P-40 Wheels Diamond Tread



**Q72296 1/72** P-40 Wheels Block Tread



**Q72301 1/72** P-40 Cockpit Sidewalls and Control Column



**Q72297 1/72** P-40 Wheels Cross Tread



**Q72298 1/72** P-40 Wheels Diamond and Hole Tread

**Q72309 1/72** P-40E-N Control Column (3 pcs)



**7386 1/72** P-40 Control Surfaces



**7387 1/72** P-40 Undercarriage Set



**7388 1/72** P-40 Engine Set



**7389 1/72** P-40E/K/M/N Armament Set



facebook.com/specialhobby  
**WWW.SPECIALHOBBY.EU**  
**WWW.CMKKITS.COM**

