

Made in Brazil

fcm Tarquinia 48 20

1944
Brazilian T-Bolts at War
4th / 350th Fighter Group

<http://www.fcm.eti.br> P-47D

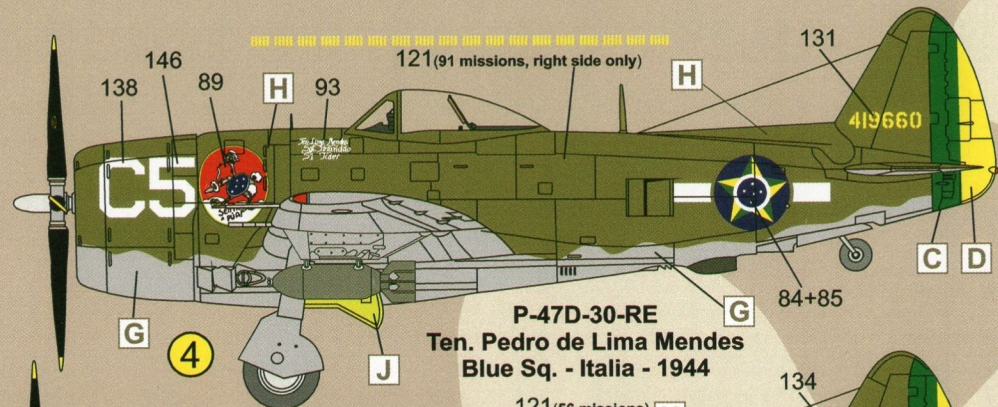

P-47D-30-RE
Ten. Pedro de Lima Mendes
Blue Sq. - Italia - 1944

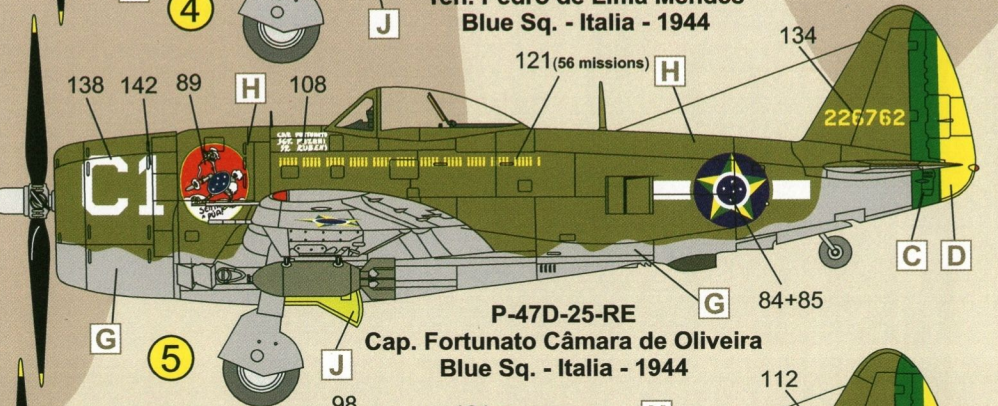

P-47D-25-RE
Cap. Fortunato Câmara de Oliveira
Blue Sq. - Italia - 1944

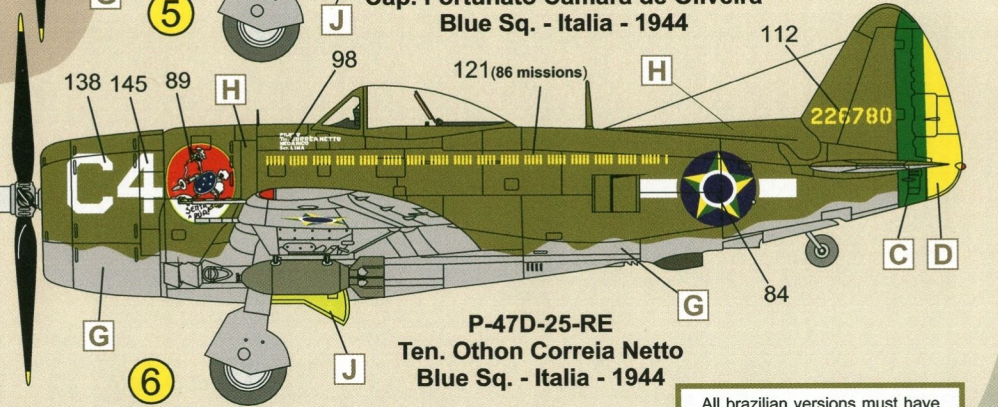

P-47D-25-RE
Ten. Othon Correia Netto
Blue Sq. - Italia - 1944

All brazilian versions must have the rudder's green/yellow band painted with colors matching the insignias.

COLORS TABLE

A	Preto	Black	FS 27038	F	Aluminio	Painted Aluminum	FS 17178
B	Branco	White	FS 27875	G	Cinza Medio	Neutral Gray	FS 36293
C	Verde	Insignia Green	FS 24090	H	Verde Castanho	Olive Drab	FS 34087
D	Amarelo	Insignia Yellow	FS 23655	I	Vermelho	Bright Red	FS 11310
E	Metal Natural	Natural Metal	FS - - - -	J	Cromato de Zinco	Zinc Chromate	FS 33481

All FS codes are conjectural

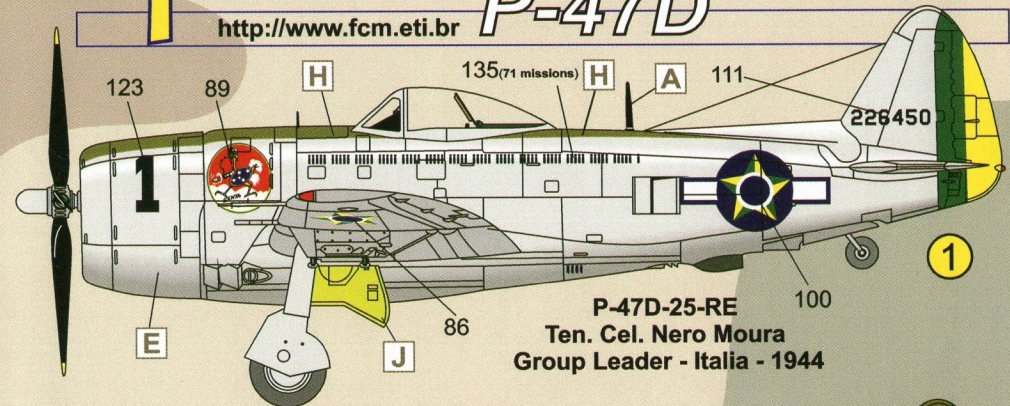

P-47D-25-RE
Ten. Cel. Nero Moura
Group Leader - Italia - 1944

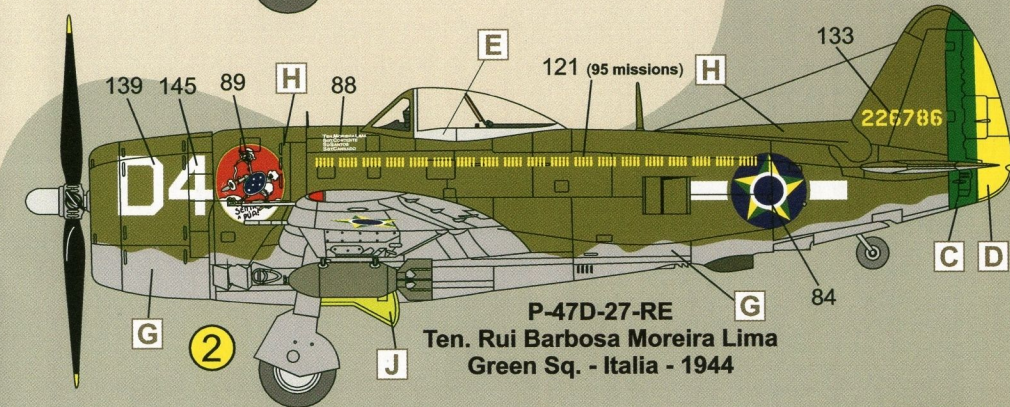

P-47D-27-RE
Ten. Rui Barbosa Moreira Lima
Green Sq. - Italia - 1944

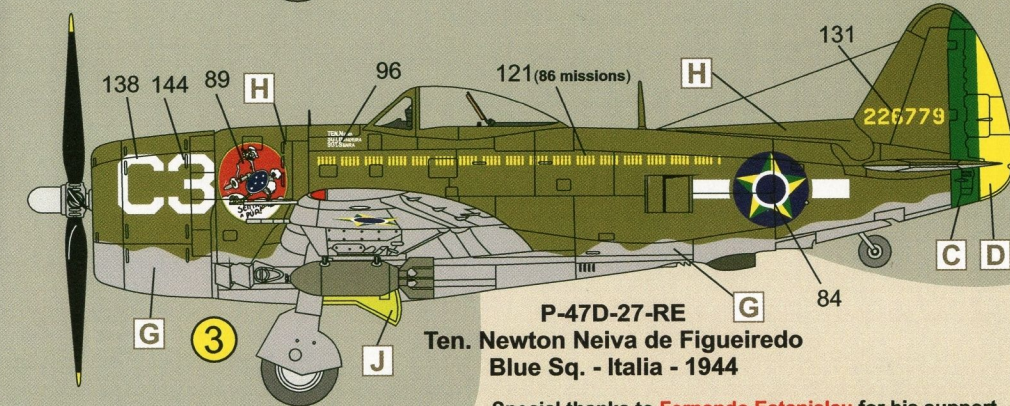

P-47D-27-RE
Ten. Newton Neiva de Figueiredo
Blue Sq. - Italia - 1944

Special thanks to **Fernando Estanislau** for his support with reviewing all data and color information for the brazilian T-bolts.

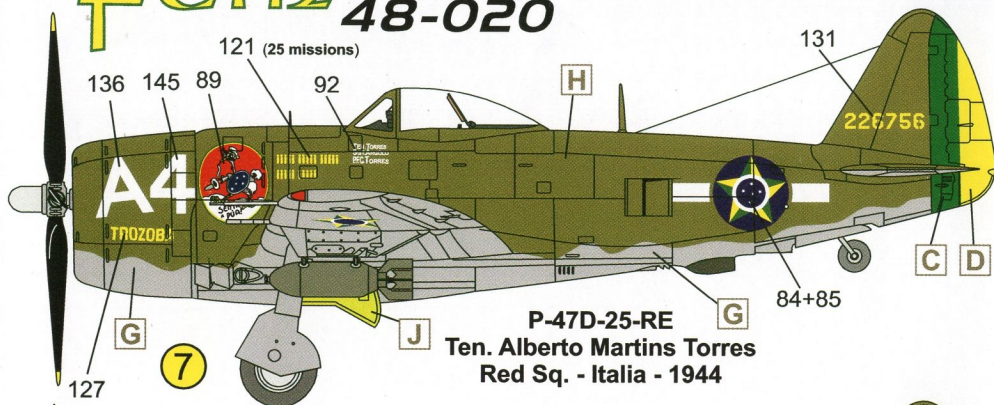

P-47D-25-RE
 Ten. Alberto Martins Torres
 Red Sq. - Italia - 1944

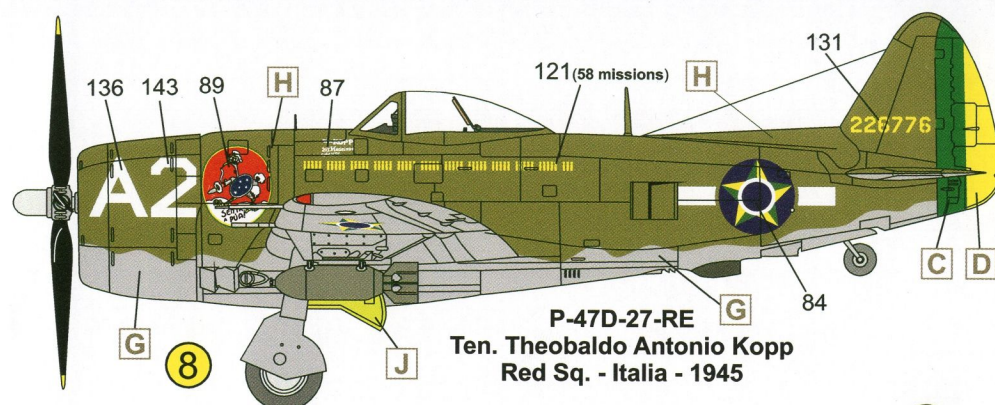

P-47D-27-RE
 Ten. Theobaldo Antonio Kopp
 Red Sq. - Italia - 1945

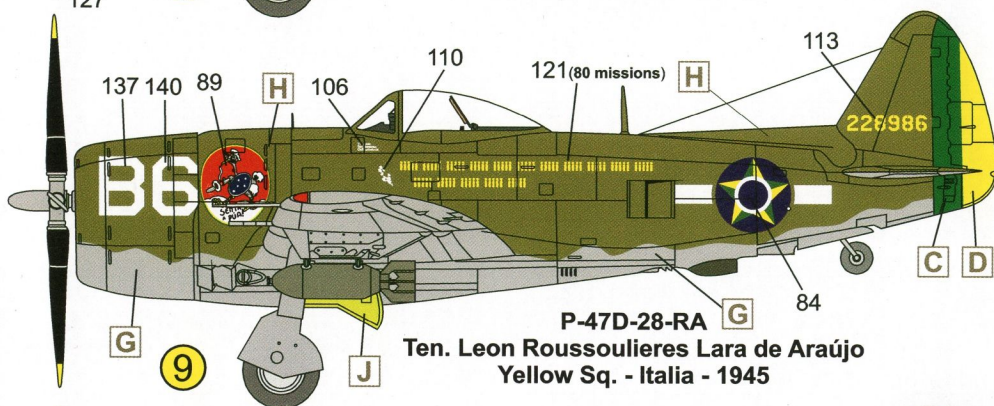

P-47D-28-RA
 Ten. Leon Roussoulieres Lara de Araújo
 Yellow Sq. - Italia - 1945

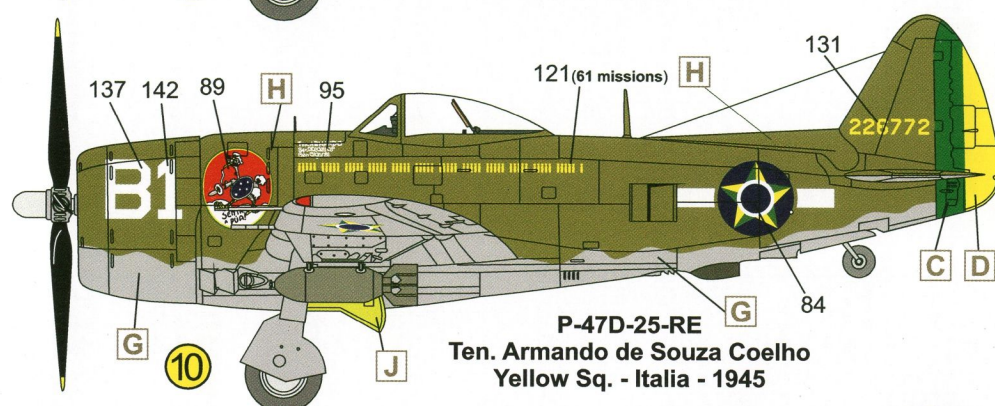

P-47D-25-RE
 Ten. Armando de Souza Coelho
 Yellow Sq. - Italia - 1945

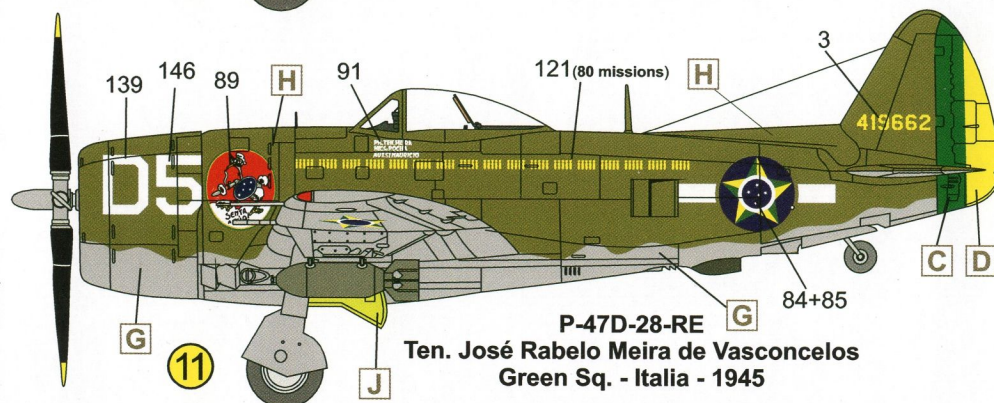

P-47D-28-RE
 Ten. José Rabelo Meira de Vasconcelos
 Green Sq. - Italia - 1945

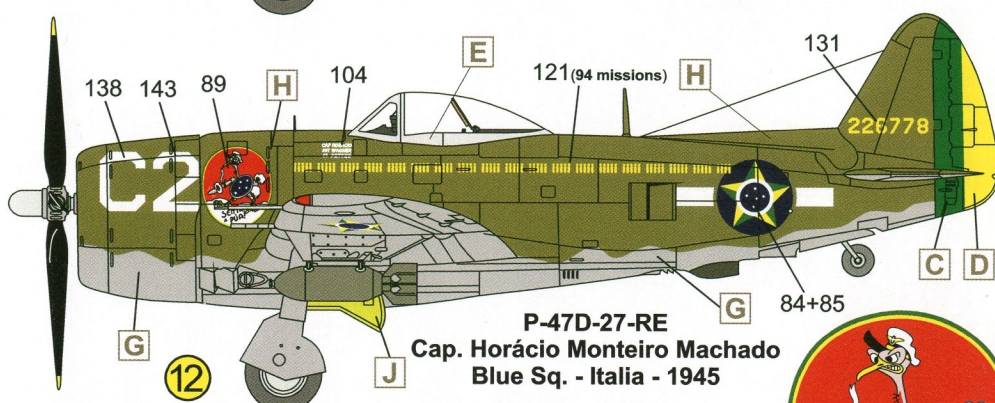

P-47D-27-RE
 Cap. Horácio Monteiro Machado
 Blue Sq. - Italia - 1945

Norfolk , Virginia, USA - 20.09.1944 (Wednesday) - Here begins the story of the "ostrich with cap". Ready to embark for the theater of operations, with the battle cry in all throats, but the group was missing a badge . It fell to Captain Aviator Fortunato Camara de Oliveira , Commander of Blue Squadron, an artist whose the impactful creativity was characteristic , he draw it , which was done on the ship "Colombie" , which carried the Unit from the Port of Norfolk - Virginia, USA , to the port of Livorno. Then appeared for the first time , the athletic figure of Ostrich 1st Fighter Group, who never hid his head from danger , as stated in the tradition of his cousins . Instead, they led in their war missions, painted on engine cowling of the Thunderbolts , were awarded for bravery acts by the U.S. government , as proposed by the 12th Tactical Air Force of the USAAF commander, whom the 1st Fighter Group was operationally subordinated in the Mediterranean operations theater, as fourth squadron of 350th Fighter Group.

Photographic references:
 Força Aérea Magazine
 "Heróis dos Céus" Book
 Aeroespacial Museum - Brasil
<http://www.sentandoapua.com.br/portal/>



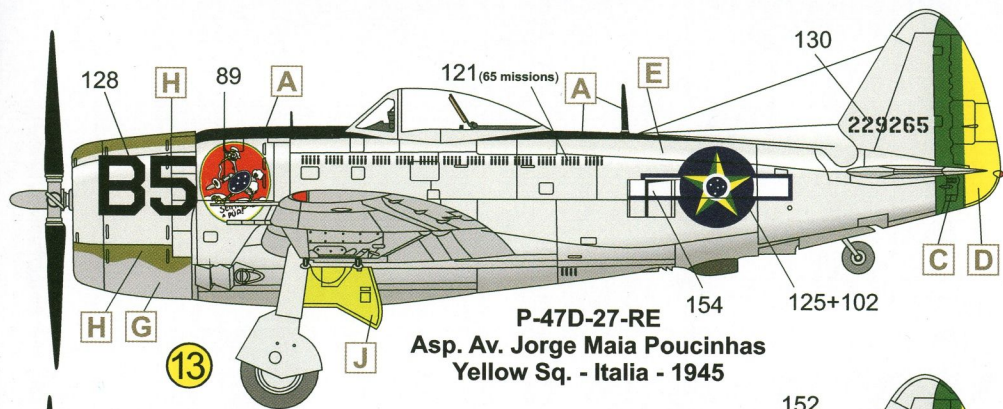

P-47D-27-RE
Asp. Av. Jorge Maia Poucinhas
Yellow Sq. - Italia - 1945

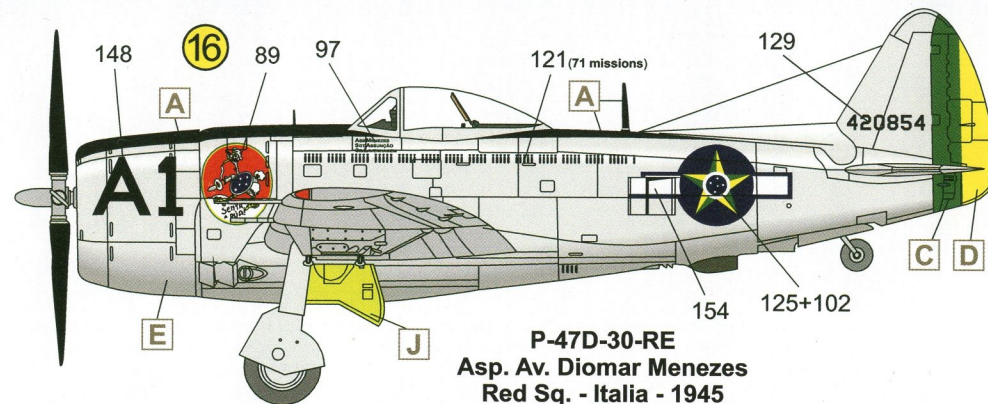

P-47D-30-RE
Asp. Av. Diomar Menezes
Red Sq. - Italia - 1945

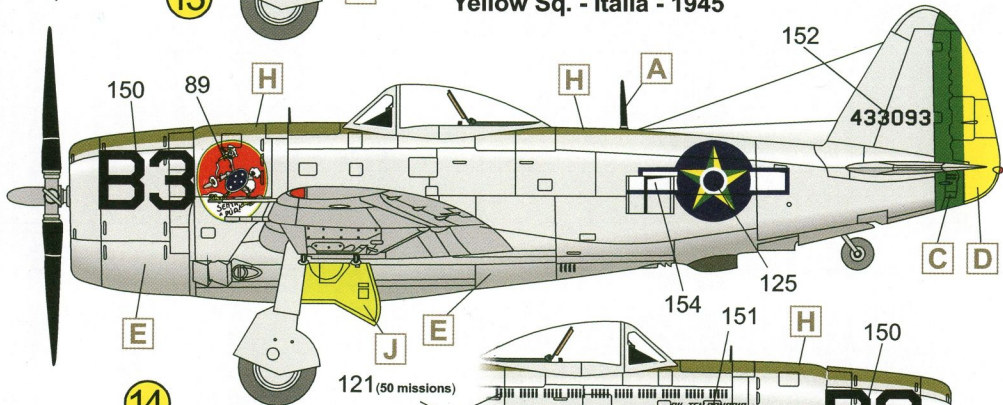

P-47D-28-RE
Ten. Raymundo da Costa Canário
Yellow Sq. - Italia - 1944

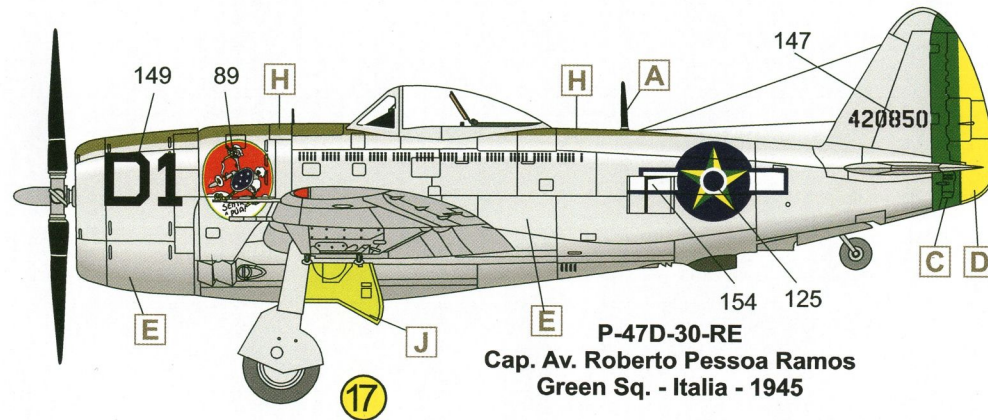

P-47D-30-RE
Cap. Av. Roberto Pessoa Ramos
Green Sq. - Italia - 1945

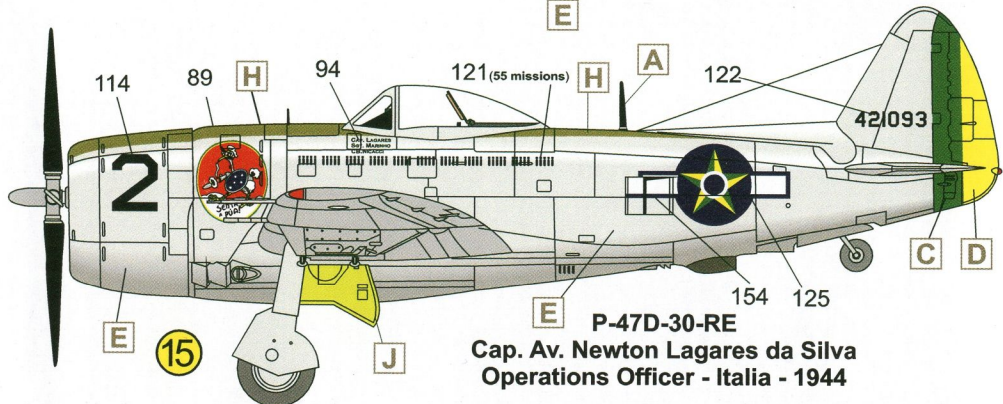
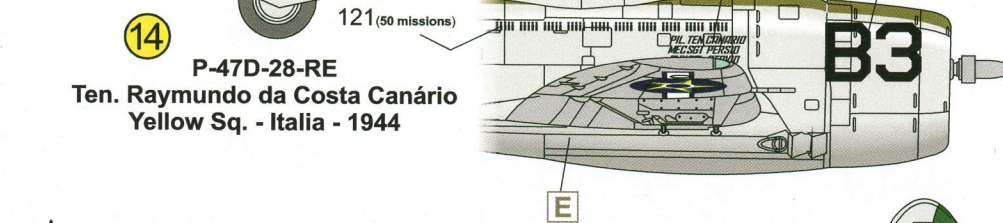

P-47D-30-RE
Cap. Av. Newton Lagares da Silva
Operations Officer - Italia - 1944

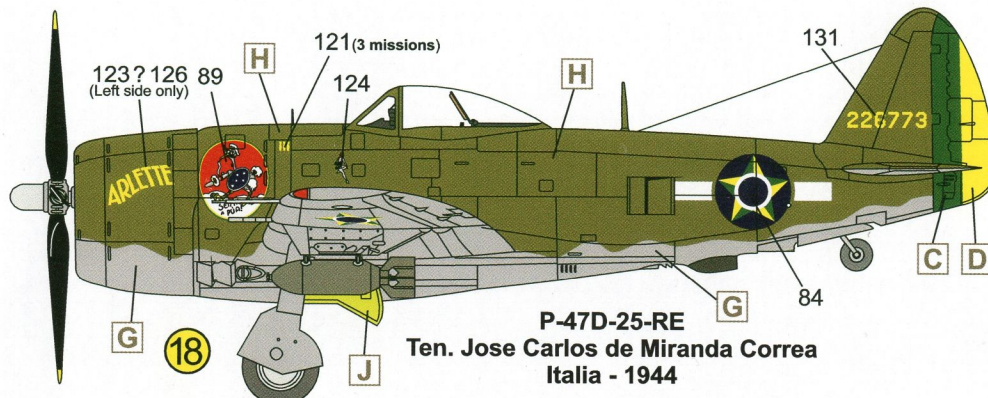

P-47D-25-RE
Ten. Jose Carlos de Miranda Correa
Italia - 1944

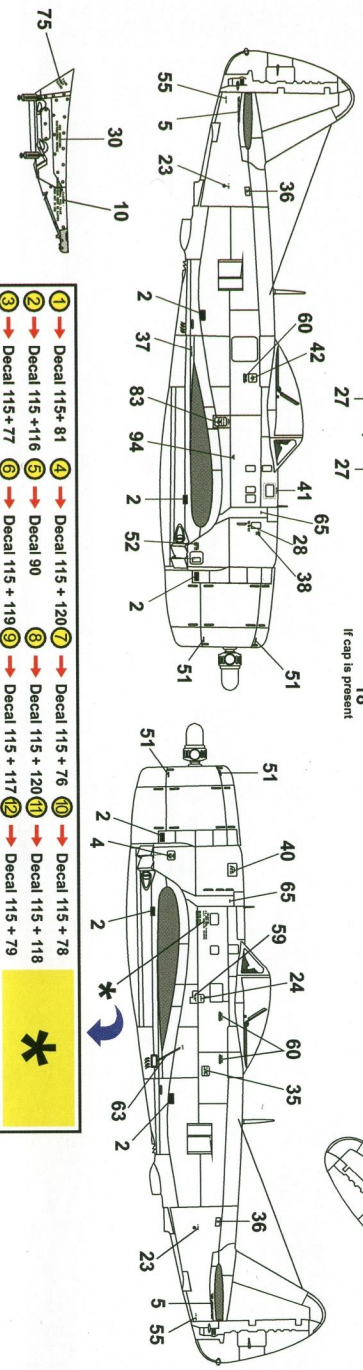
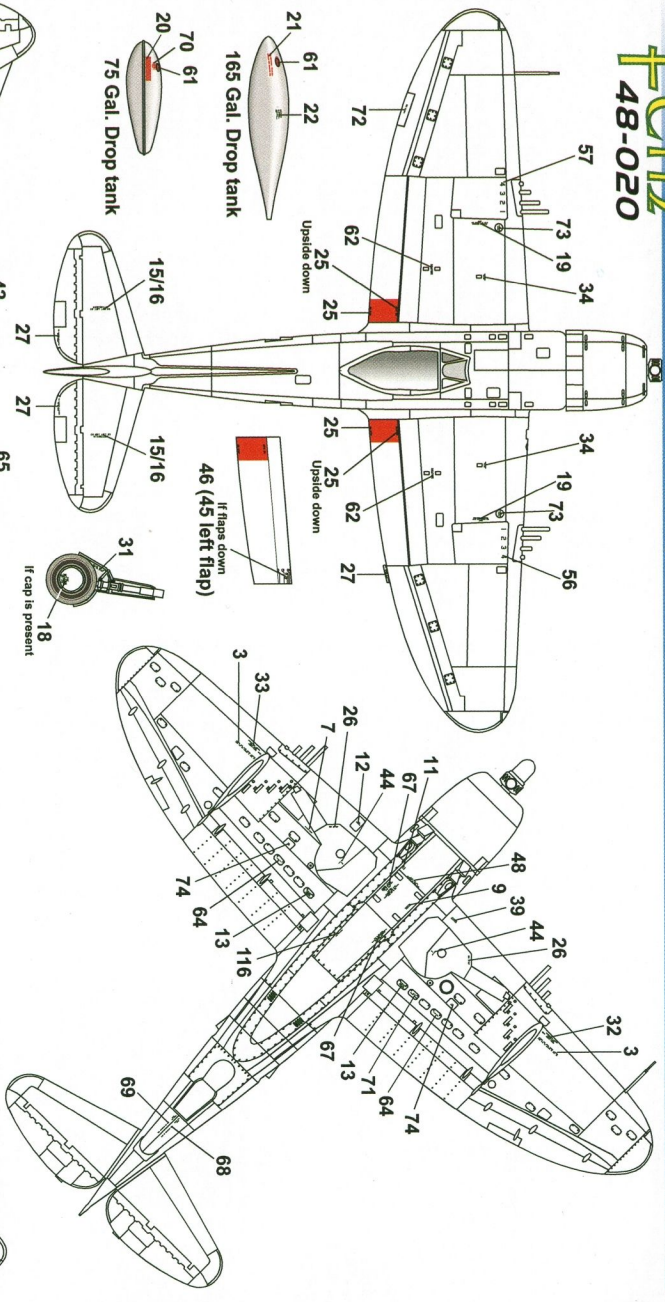
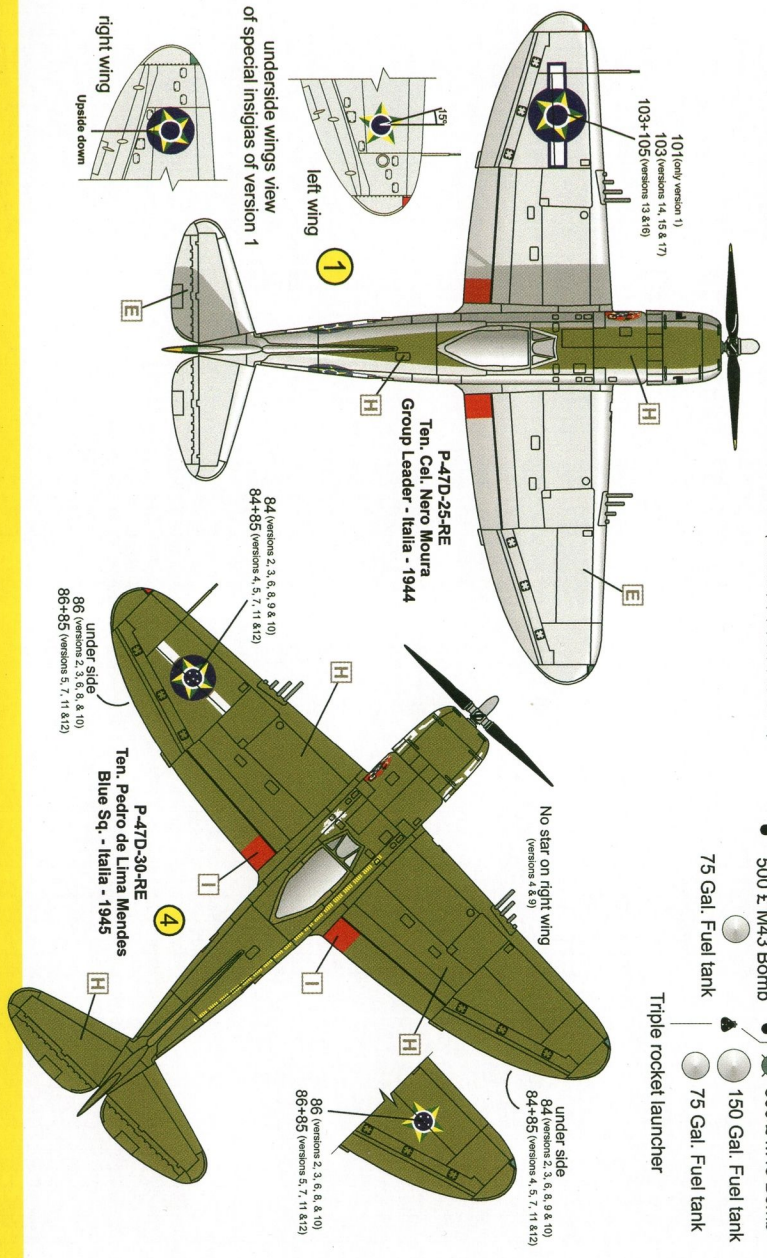
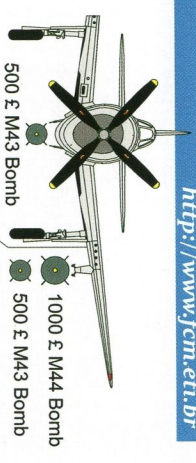
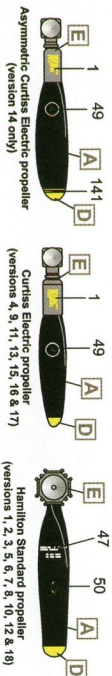

- ① → Decal 115+ 81
- ② → Decal 115 +116
- ③ → Decal 115+ 77
- ④ → Decal 115 + 120
- ⑤ → Decal 90
- ⑥ → Decal 115 + 119
- ⑦ → Decal 115 + 76
- ⑧ → Decal 115 + 120
- ⑨ → Decal 115 + 117
- ⑩ → Decal 115 + 78
- ⑪ → Decal 115 + 118
- ⑫ → Decal 115 + 79



