



KIT 4548

F-89D/J Scorpion

1/48 SCALE 1/48 ECHELLE

ESCALA 1/48

REVELL, INC. Des Plaines, IL Copyright © 1990 All rights reserved. Made in U.S.A.

4548 R 4200

The sleek F-89 Scorpion was the first turbojet, all-weather fighter-interceptor developed for the United States Air Force. Designed as a successor to the famed P-61 Black Widow, the potent F-89 established new standards for air defense interceptors and served with U.S. Air Force and Air National Guard units for nearly 20 years.

Powered by twin Allison J-35 turbojet engines, the Scorpion was an innovative creation due to the unusual thin, straight wings that were utilized in place of the accepted swept wing design. The broad wings endowed the F-89 with excellent flight characteristics throughout the performance envelope due to the split decelerons that could be utilized as ailerons or deployed as speed brakes. It was operated by a two-man crew composed of a pilot and radar intercept officer who were seated in tandem in a pressurized cockpit.

The lethal F-89D was the world's most heavily armed fighter in the mid-fifties. The most significant improvements in this variant were the wing tip-

mounted rocket pod/fuel tanks and sophisticated Hughes fire control system. The forward section of each pod contained fifty-two 2.75-inch folding fin rockets that could be fired individually or in a lethal salvo of 104 projectiles. The fuel tanks contained 300 gallons of fuel per tank, and uprated J-35 engines enabled the maximum gross weight to exceed 46,700 pounds. 683 aircraft were constructed, and an F-89D established aviation history on July 19, 1957, when a test aircraft launched a nuclear-tipped MB-1 Genie rocket.

The continuing need for improved air defense with improved long-range strike capabilities mandated the conversion of 350 F-89Ds to the definitive F-89J. The rocket pod/fuel tanks were replaced with 600-gallon fuel tanks, and the wings were equipped with external pylons armed with two MB-1 Genie nuclear rockets and four GAR-2 Falcon guided missiles.

An imposing aircraft, the F-89 spanned 60 feet, 5 inches (F-89D) and was 53 feet, 10 inches long. It possessed a maximum range of 2,600 miles.

READ THIS BEFORE YOU BEGIN

- Study the assembly drawings.
- Each plastic part is identified by a number.
- Check the fit of each piece before cementing in place.
- Do not use too much cement to join parts.
- Use only cement for polystyrene plastic.
- Model may be painted to match photos on box.
- Allow paint to dry thoroughly before handling parts.
- Scrape paint from areas to be cemented.
- For better paint and decal adhesion, wash the plastic parts in a mild detergent solution. Rinse and let air dry.

LISEZ CE QUI SUIT AVANT DE COMMENCER**LE MONTAGE**

- Etudiez les schémas d'assemblage.

- Chaque pièce plastique porte un numéro d'identification.
- Contrôlez que chaque pièce soit bien conforme avant de la coller à sa place.
- N'utilisez pas trop de colle pour réunir les pièces.
- Utilisez uniquement une colle spéciale pour polystyrène.
- Le modèle peut être peint conformément aux photos sur la boîte.
- Laissez sécher la peinture complètement, avant de manipuler les pièces.
- Grattez la peinture sur les surfaces devant être collées.
- Pour assurer la meilleure adhésion possible de la peinture et des décalcomanies, lavez les pièces de plastique avec une légère solution savonneuse. Rincer et laisser sécher à l'air.

LEA ESTO ANTES DE EMPEZAR

- Estudie los dibujos de ensamblaje.
- Cada pieza de plástico se identifica por un número.
- Verifique que cada pieza encaje bien antes de pegar en posición.
- No use demasiado pegamento para unir las piezas.
- Use únicamente pegamento para plástico de poliestirena.
- El modelo puede pintarse de acuerdo con las fotografías de la caja.
- Permita que se seque la pintura completamente antes de tocar las piezas.
- Raspe la pintura de las superficies que serán pegadas.
- Para una mejor fijación de la pintura y de las calcomanías, lávense las piezas plásticas en una solución de detergente suave. Enjuáguese y déjense secar al aire.



OPTIONAL PARTS
PIECES EN OPTION
PIEZAS OPCIONALES



REMOVE AND THROW AWAY
À RETIRER ET JETER
QUITE Y TIRE



REPEAT SEVERAL TIMES
À REPETER PLUSIEURS FOIS
REPITA VARIAS VECES



DECAL (DIP IN WATER)
DECALCOMANIE (À PLONGER DANS L'EAU)
DECALCOMANIA (MOJE CON AGUA)

A	ALUMINUM	ALUMINIUM	ALUMINIO
B	RED	ROUGE	ROJO
C	FLAT BLACK	NOIR TERNE	NEGRO APAGADO
D	LIGHT GRAY	GRIS CLAIR	GRIS CLARO
E	WHITE	BLANC	BLANCO
F	BLUE	BLEU	AZUL
G	DARK GRAY	GRIS FONCE	GRIS OSCURO
H	SILVER	ARGENT	PLATA
J	METALLIC	METALLIC	METALICO
K	SKIN COLOR	COULEUR DE LA PEAU	COLOR DE LA PIEL
L	OLIVE GREEN	VERT OLIVE	VERDE OLIVA

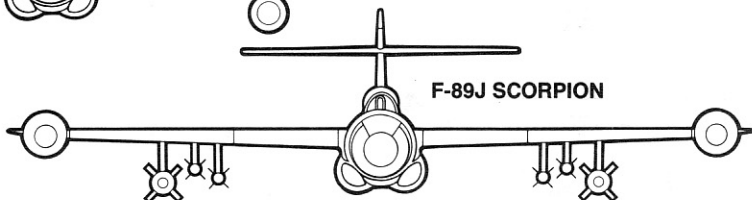
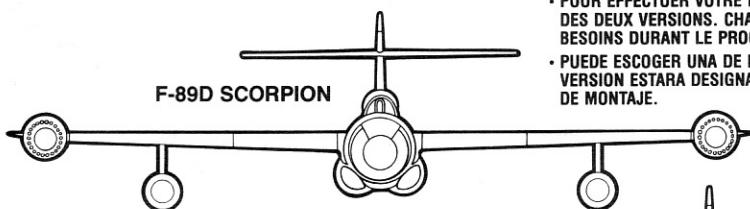

- YOU MAY CHOOSE ONE OF TWO VERSIONS IN YOUR ASSEMBLY. EACH VERSION WILL BE DESIGNATED WHERE REQUIRED IN THE ASSEMBLY PROCEDURE.
- POUR EFFECTUER VOTRE MONTAGE, VOUS POUVEZ CHOISIR UNE DES DEUX VERSIONS. CHAQUE VERSION SERA DESIGNEE SELON LES BESOINS DURANT LE PROCESSUS DE MONTAGE.
- PUEDE ESCOGER UNA DE DOS VERSIONES PARA SU MONTAJE. CADA VERSION ESTARA DESIGNADA CUANDO SEA NECESARIO EN EL PROCESO DE MONTAJE.

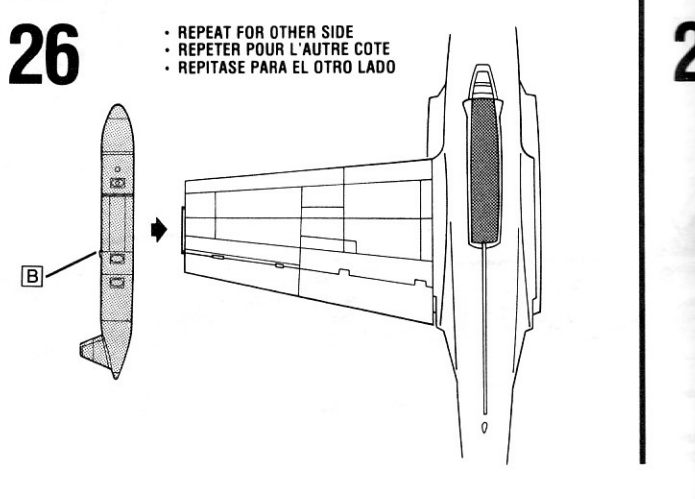
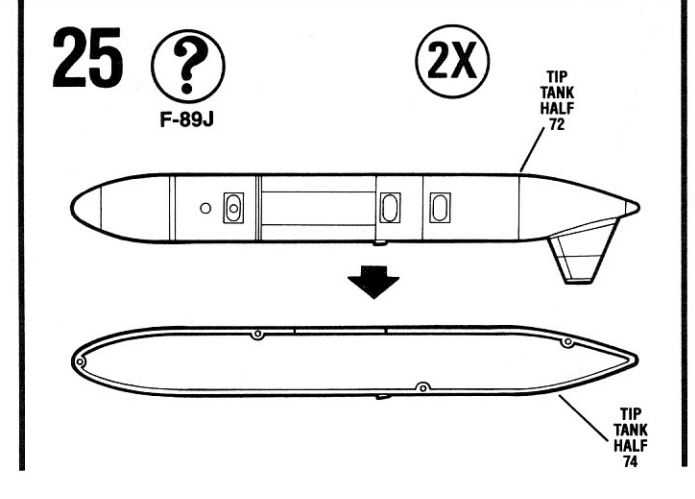
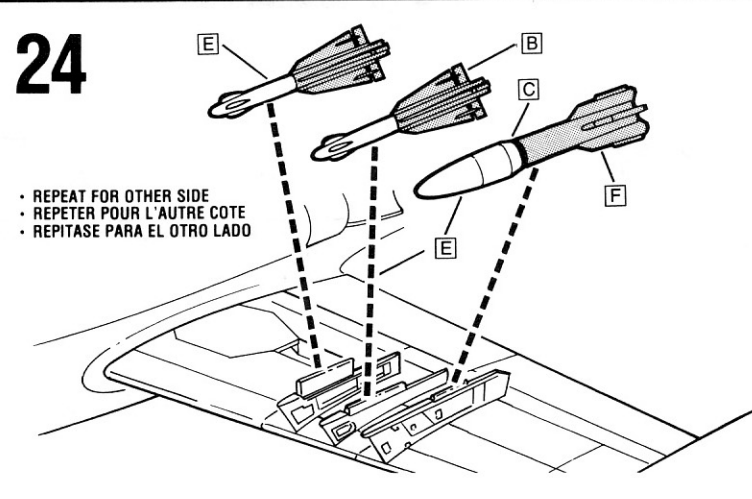
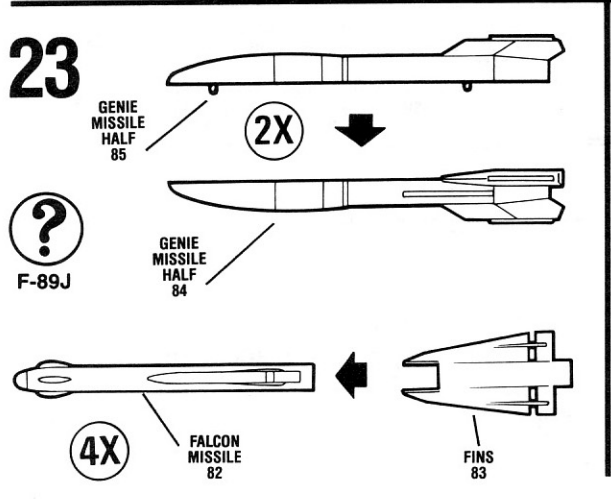
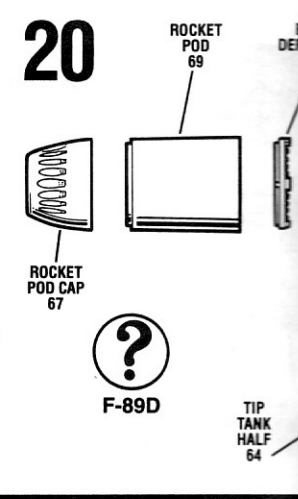
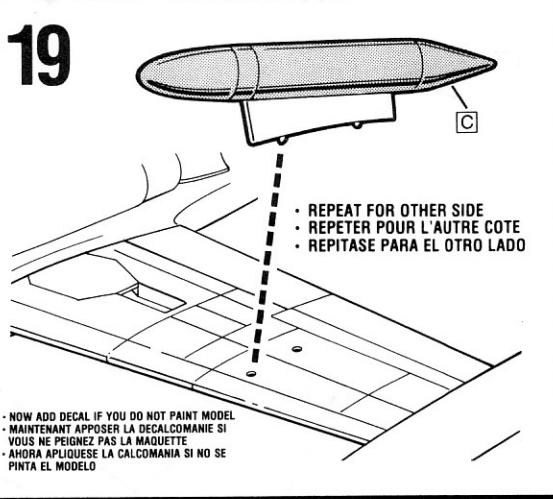
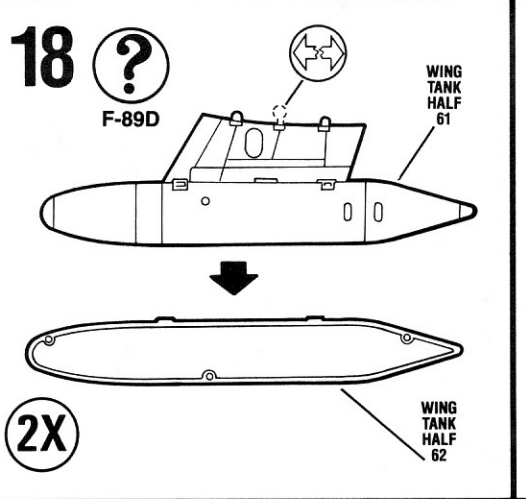
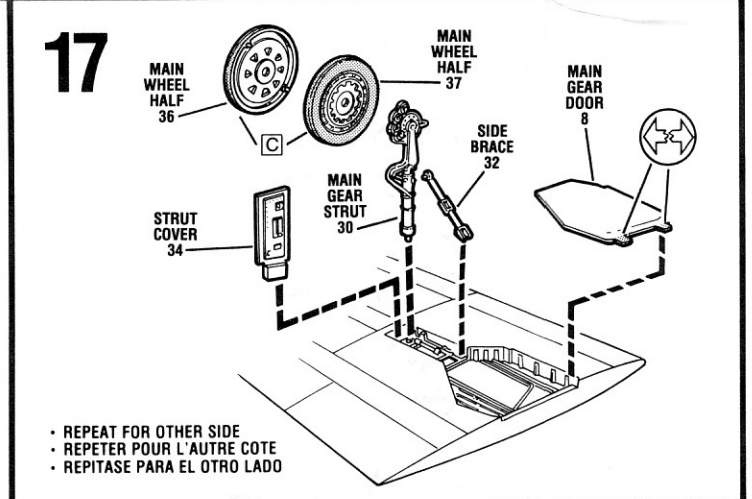
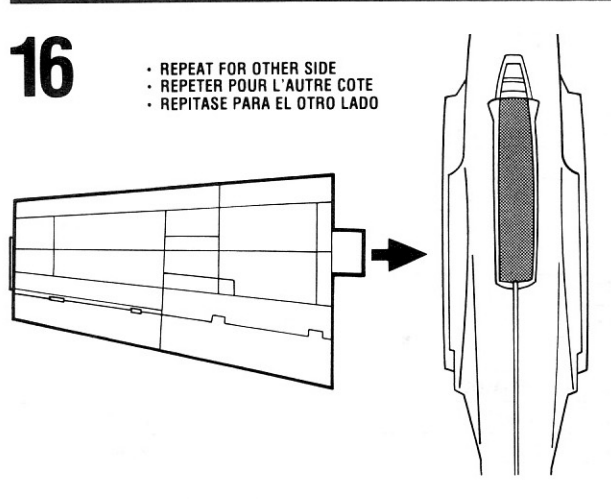
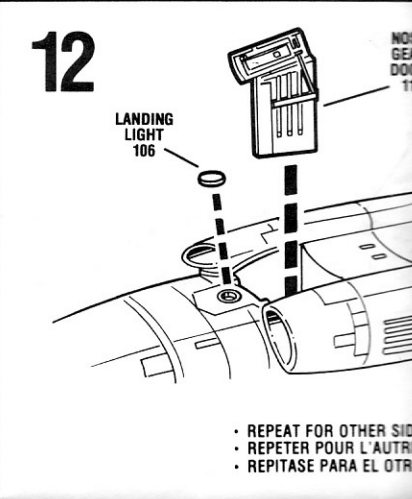
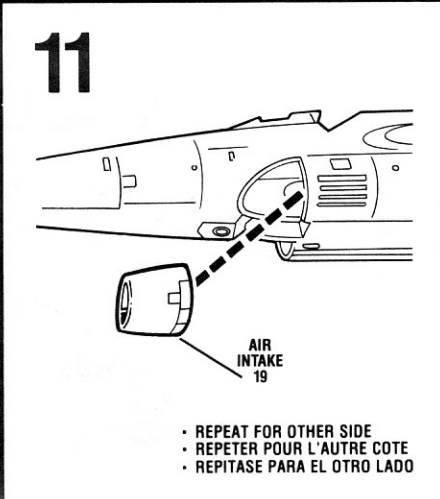
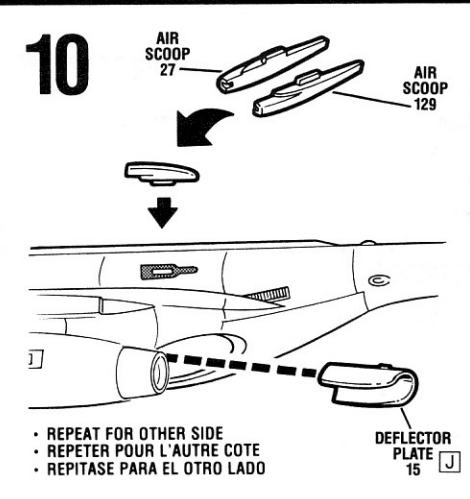
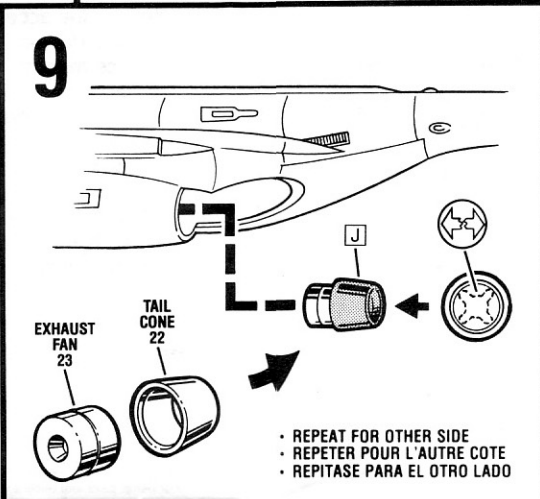
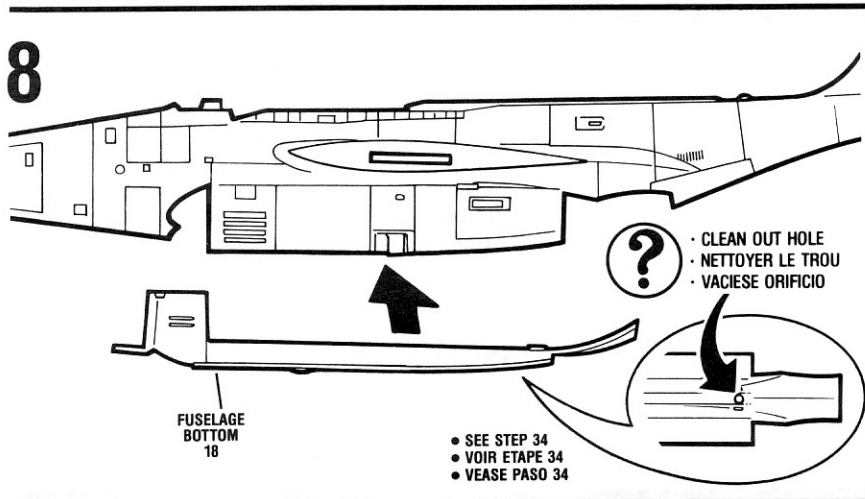
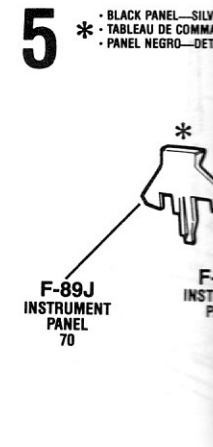
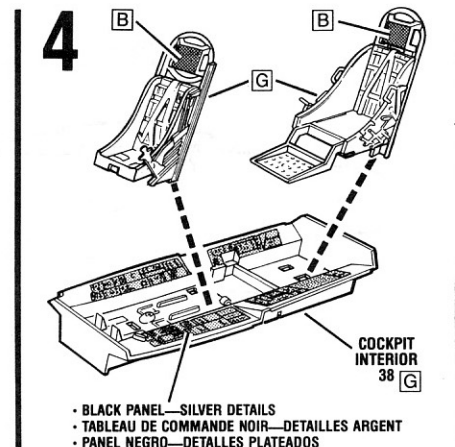
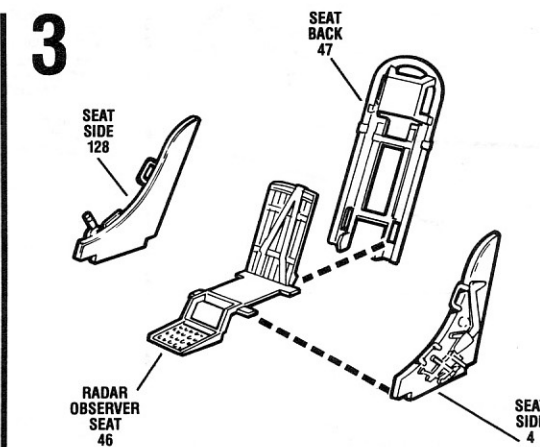
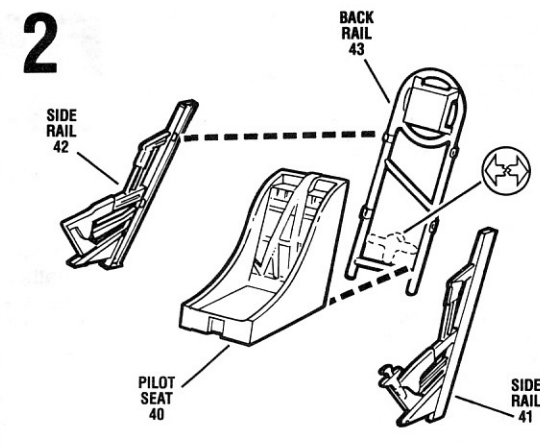
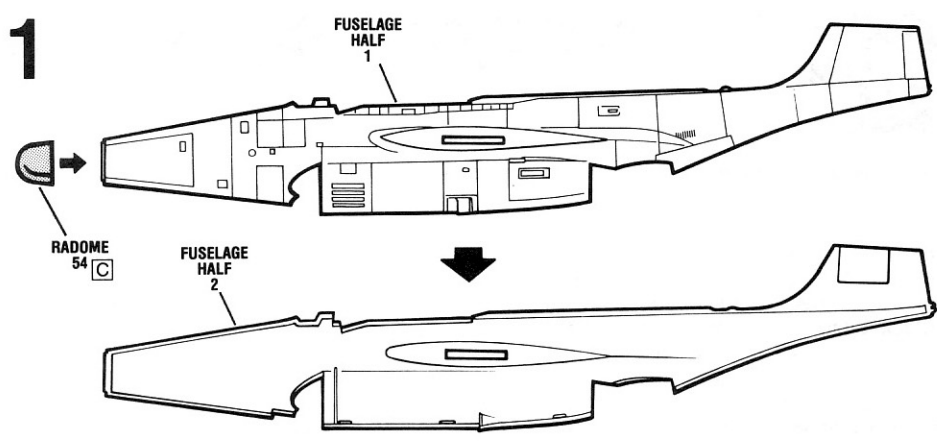

4

SEAT SIDE 4

COCKPIT INTERIOR 38

- BLACK PANEL—SILVER DETAILS
- TABLEAU DE COMMANDE NOIR—DETAILLES ARGENT
- PANEL NEGRO—DETALLES PLATEADOS

5

RADIO COMPASS 103

F-89D INSTRUMENT PANEL 60

CONTROL STICK 39

CONTROL STICK 48

F-89J INSTRUMENT PANEL 70

F-89D INSTRUMENT PANEL 59

F-89J INSTRUMENT PANEL 71

F-89J RADAR SCOPE 58

- SEE STEP 30
- VOIR ETAPE 30
- VEASE PASO 30

6

INTAKE FANS 21

7

INTAKE FANS 21

11

AIR INTAKE 19

- REPEAT FOR OTHER SIDE
- REPETER POUR L'AUTRE COTE
- REPITASE PARA EL OTRO LADO

12

NOSE GEAR DOOR 11

LANDING LIGHT 106

- REPEAT FOR OTHER SIDE
- REPETER POUR L'AUTRE COTE
- REPITASE PARA EL OTRO LADO

13

NOSE WHEEL 13

NOSE GEAR STRUT 24

DRAG BRACE 28

ACTUATING CYLINDER 25

GEAR TRUSS 26

14

15

WING TOP 5

WING TOP 6

WING BOTTOM 56

WING BOTTOM 57

F-89D 2X

F-89J 6X

F-89D 2X

F-89J 6X

- CLEAN OUT HOLE
- NETTOYER LE TROU
- VACIESE ORIFICIO

9

ROCKET POD 69

BLAST DEFLECTOR 68

TIP TANK HALF 63

ROCKET POD CAP 67

TIP TANK HALF 64

- REPEAT FOR OTHER SIDE
- REPETER POUR L'AUTRE COTE
- REPITASE PARA EL OTRO LADO

ADD DECAL IF YOU DO NOT PAINT MODEL
 MAINTENANT APOSER LA DECALCOMANIE SI
 VOUS NE PEIGNEZ PAS LA MAQUETTE
 APLIQUESE LA CALCOMANIA SI NO SE
 PINTA EL MODELO

20

ROCKET POD 69

BLAST DEFLECTOR 68

TIP TANK HALF 63

ROCKET POD CAP 67

TIP TANK HALF 64

F-89D

21

TAIL TIP 29

HORIZONTAL STABILIZER 3

- REPEAT FOR OTHER SIDE
- REPETER POUR L'AUTRE COTE
- REPITASE PARA EL OTRO LADO

22

INBOARD PYLON 81

CENTER PYLON 79

OUTBOARD PYLON 77

F-89J

- REPEAT FOR OTHER SIDE
- REPETER POUR L'AUTRE COTE
- REPITASE PARA EL OTRO LADO

NOW ADD DECAL IF YOU DO NOT PAINT MODEL
 MAINTENANT APOSER LA DECALCOMANIE SI
 VOUS NE PEIGNEZ PAS LA MAQUETTE
 AHORA APLIQUESE LA CALCOMANIA SI NO SE
 PINTA EL MODELO

26

TAIL TIP 29

HORIZONTAL STABILIZER 3

- REPEAT FOR OTHER SIDE
- REPETER POUR L'AUTRE COTE
- REPITASE PARA EL OTRO LADO

TIP TANK HALF 74

27

TAIL TIP 29

HORIZONTAL STABILIZER 3

28

PITOT TUBE 17

29

PITOT TUBE 130

30

PITOT TUBE 130

- OPTIONAL: PILOT 51 WITH ARM 52 — SEE REAR PAGE FOR PAINTING
- FACULTATIF: PILOTE 51 AVEC BRAS 52 — VOIR VERSO POUR FINITION
- OPCIONAL: PILOTO 51 CON BRAZO 52 — VEASE LA PAGINA POSTERIOR PARA LA PINTURA
- OPTIONAL: CREWMAN 49 WITH ARM 50 — SEE REAR PAGE FOR PAINTING
- FACULTATIF: MEMBRE D'EQUIPAGE 49 AVEC BRAS 50 — VOIR VERSO POUR FINITION
- OPCIONAL: TRIPULANTE 49 CON BRAZO 50 — VEASE LA PAGINA POSTERIOR PARA LA PINTURA

31

- FRAME IS FUSELAGE COLOR
- LES MONTANTS SONT DE LA COULEUR DU FUSELAGE
- ARMAZON DEL COLOR DEL FUSELAJE

WINDSHIELD 100

CANOPY 101

CANOPY FRAME 14

32

F-89J

WIND DEFLECTOR 104

33

- OPTIONAL CANOPY POSITIONS
- POSITIONS POSSIBLES DE LA VERRIERE
- POSICIONES OPCIONALES DE LA CARLINGA

34

SUPPORT PEG 107

- REMAINING PARTS MAY BE DISCARDED.
- SE DEFAIRE DES PIÈCES RESTANTES.
- LAS PIEZAS QUE SOBREN PUEDEN DESCARTARSE.

- CREWMAN PAINTING... WHITE HELMET WITH BLACK TRIM, OLIVE GREEN SUIT, LIGHT GRAY PARACHUTE STRAPS WITH SILVER BUCKLES, DARK GRAY MASK AND HOSE, BLACK BOOTS.
- FINITION DU MEMBRE D'EQUIPAGE... CASQUE BLANC AVEC BORDURE NOIRE, UNIFORME VERT-OLIVE, SANGLES DE PARACHUTE GRIS CLAIR AVEC BOUCLES ARGENT, MASQUE ET TUYAU FLEXIBLE GRIS FONCE, BOTTES NOIRES.
- PINTURA DEL TRIPULANTE... CASCO BLANCO CON BORDE NEGRO, TRAJE VERDE OLIVA, CORREAS DE PARACAIDAS GRIS CLARO CON HEBILLAS PLATEADAS, MASCARA Y TUBO GRIS OSCURO, BOTAS NEGRAS.

Revell, Incorporated has put forth every effort to create and manufacture the finest model kit available. If a part may be missing, please write to:

Revell, Incorporated
 Consumer Service Department
 395 North Third Avenue
 Des Plaines, Illinois 60016

Be sure to include the kit number, part number, description, and your return address.

F-89D SCORPION

- DECAL WRAPS AROUND NOSE
- LA DECALCOMANIE ENVELOPPE LE NEZ
- LA CALCOMANIA SE APLICA ALREDEDOR DEL EXTREMO ANTERIOR

- LEFT WING BOTTOM
- DESSOUS DE L'AILE GAUCHE
- PARTE INFERIOR DEL ALA IZQUIERDA

- RIGHT WING BOTTOM
- DESSOUS DE L'AILE DROITE
- PARTE INFERIOR DEL ALA DERECHA

F-89J SCORPION

- LEFT WING BOTTOM
- DESSOUS DE L'AILE GAUCHE
- PARTE INFERIOR DEL ALA IZQUIERDA

- RIGHT WING BOTTOM
- DESSOUS DE L'AILE DROITE
- PARTE INFERIOR DEL ALA DERECHA

Revell, Inc. wishes to thank Dave Menard, the U.S. Air Force Museum, and Robert Johnson of the Pima Air Museum for their assistance in the development of this model.

1 NO STEP NO STEP NO STEP NO STEP NO STEP NO STEP 3

NO STEP NO STEP NO STEP NO STEP NO STEP NO STEP

NO STEP NO STEP NO STEP NO STEP NO STEP NO STEP



6

U.S. AIR FORCE
22155

U.S. AIR FORCE
22155

16



17

AIR NATIONAL GUARD 2-220-41-00
A-100 SERIAL NO. 12-12-66

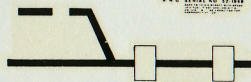

18

U.S. AIR FORCE

U.S. AIR FORCE

0-21949

0-21949

949 949

0606

4

FV-155
FV-155

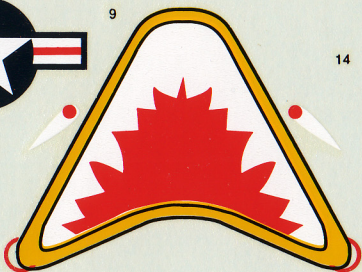
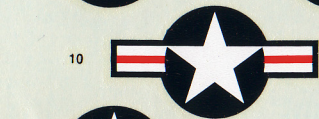
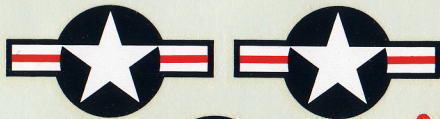

14

USAF
USAF

24

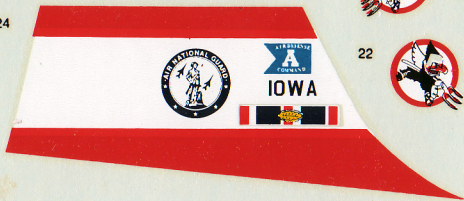

21



22



23

25



19

26

11

© 1990 REVELL INC. ALL RIGHTS RESERVED

12

13