

# LOCKHEED S-3A



Stock No. 8634  
Form No. 099-8634

## SUBMARINE-HUNTER/KILLER

More than any other single factor, it was the airplane that turned the tide against the submarine in W.W.II. Able to detect, track and kill submarines at long ranges, thus keeping them away from convoys, they sealed the fate of the U-boats and Germany as a whole. The lack of a powerful airborne-radar system able to be carried by carrier-borne aircraft was not solved until shortly after W.W.II when the APS-20 radar was mounted on modified TBM-3W Avengers. This was followed by the Grumman Guardian, the AD-4W Skyraider (available in a 1/48 scale kit from AMT/WINGS), the S-2 Tracker and, finally, the S-3A Viking.

The Viking first flew in January, 1972, and was considered an urgent program as the aging piston-engined S-2 badly needed replacement. The first production examples of the S-3 were delivered in February, 1974. However, the highly-advanced computer and sensor system necessitated a protracted workup, and it wasn't until June, 1975, that VS-21 became the first unit to go on a protracted cruise. The two-man electronic suite is so capable that it was chosen by the Canadians for their CP-140 derivative of the land-based Orion P-3 ASW aircraft. Among the sensors aboard are radar, FLIR, passive ESM, MAD and as many as 60 sonobouys.

The Viking, powered by two GE TF34 high by-pass ratio by-

pass ratio turbofan engines, is a portly, fairly surprisingly small airframe. Highly capable, the S-3 can loiter on patrol at 160 knots (184 mph) for such a long time, given its midair refueling capacity, that crew fatigue is the largest limiting factor to staying on station.

Armament options are wide, and include both internal and external stores. Rockets, bombs, depth charges, cluster bombs (CBUs), flares and torpedos can be carried. Later models can carry Harpoon anti-ship missiles. It was in this anti-submarine, anti-ship configuration the S-3A saw action in Operation Desert Storm. Typical underwing configuration is two 300 gallon (U.S.) fuel tanks, one of which is designed for "buddy system" mid-air refueling for Navy aircraft.

The S-3 has proven to be an extremely versatile aircraft, and has been modified for a variety of roles, including the US-3 priority Carrier-On-Board-Delivery (COD), the S-3B with Harpoon capability, and most recently, the highly-modified ES-3A Shadow electronic warfare/intelligence version which replaced the aging EA-3/ERA-3/KA-3 Skywarrior.

We hope you enjoy building your highly-detailed AMT/WINGS kit of this important U.S. Navy aircraft.

# 1 Tailhook Bay / MAD Boom Assembly

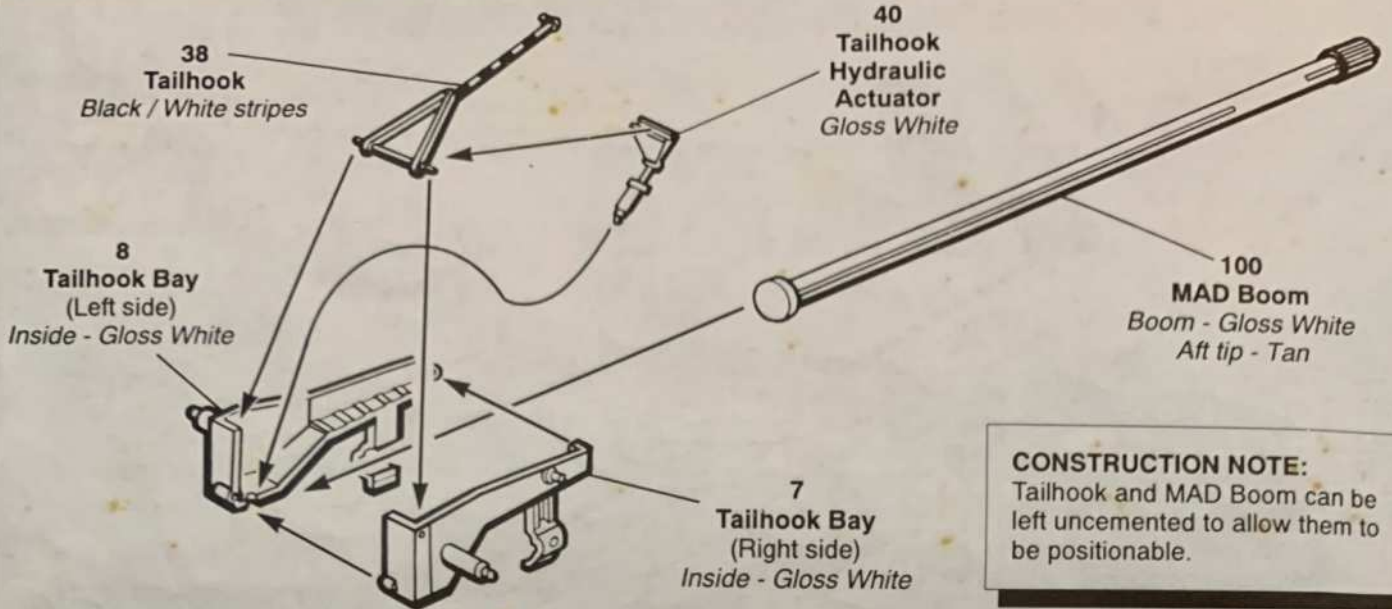

**CONSTRUCTION NOTE:**  
Tailhook and MAD Boom can be left uncemented to allow them to be positionable.

# 2 Fuselage Assembly

**CONSTRUCTION NOTE:**

- 1...Cement TAILHOOK BAY & MAD BOOM ASSEMBLY into position on right or left fuselage half.
- 2...Cement WINDOWS (106) into position on the inside of each fuselage half.
- 3...Cement FUSELAGE, Left (1) and FUSELAGE, Right (21) together. Make sure TAILHOOK BAY ASSEMBLY seats correctly

- into mounting holes. Clamp fuselage halves together with rubber bands and clothes pins to assure proper bonding.
- 4...When fuselage is dry, push a ball of modeling clay the size of a quarter into the nose through the cockpit opening. This will balance the model properly.
- 5...Cement COCKPIT FLOOR (35) into position.

**TAILHOOK BAY & MAD BOOM ASSEMBLY**

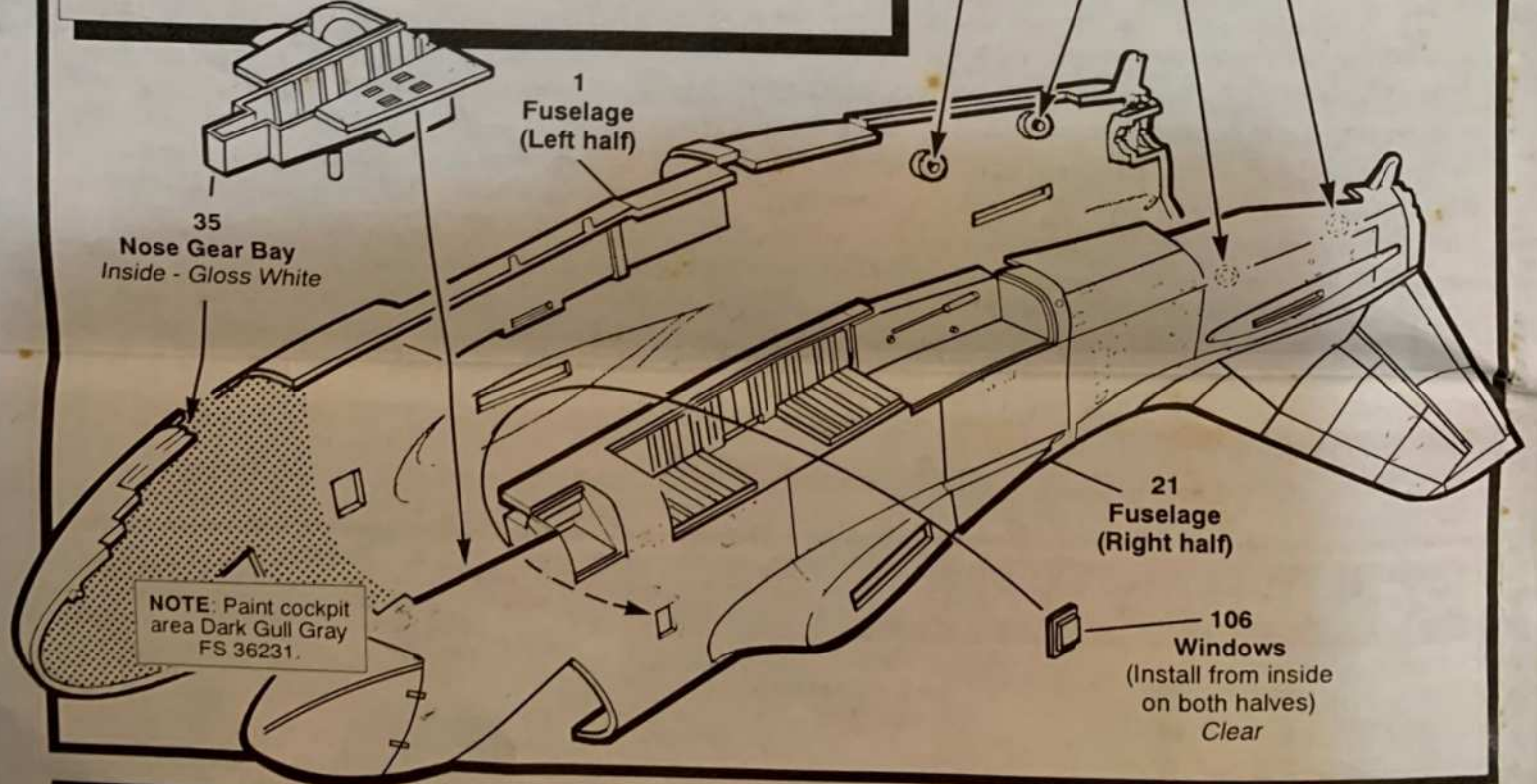
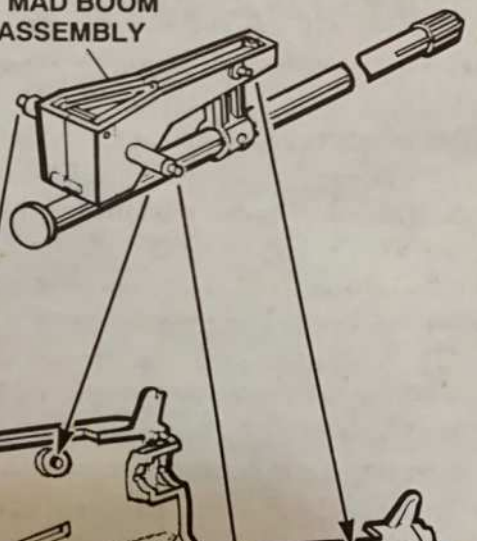

**NOTE:** Paint cockpit area Dark Gull Gray FS 36231.

### 3 FLIR Bay Assembly

#### Option 1

FLIR Dome retracted and doors closed. Cement FLIR DOORS (30) over FLIR bay.



#### Option 2

FLIR Dome retracted and doors open. Cut FLIR DOOR (30) to get two doors. Do not use (95) since the retracted FLIR dome is already part of the Nose Wheel Bay.



#### Option 3

FLIR Dome extended and doors open. Cement FLIR DOME (95) over retracted dome. Cement FLIR DOORS (30) in place.

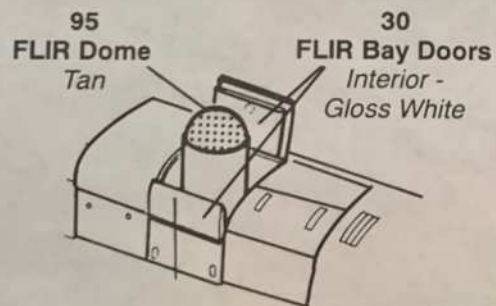

### 4 Stair Assembly

#### Option 1

Stair Door closed. Do not use STAIRS (32) but cement part STAIR DOOR (31) to fuselage over stair bay.

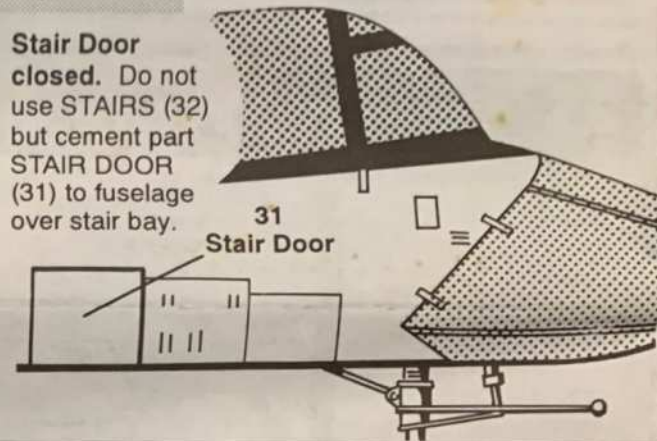

#### Option 2

Stairs open. Cement STAIR (32) to STAIR DOOR (31). Cement stair assembly to fuselage at hinge line.

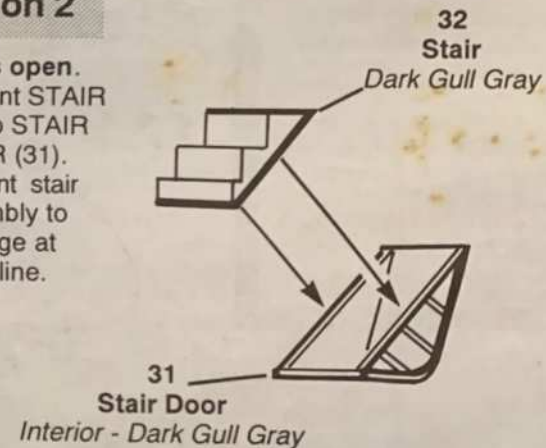

# 5 Nose Gear Installation

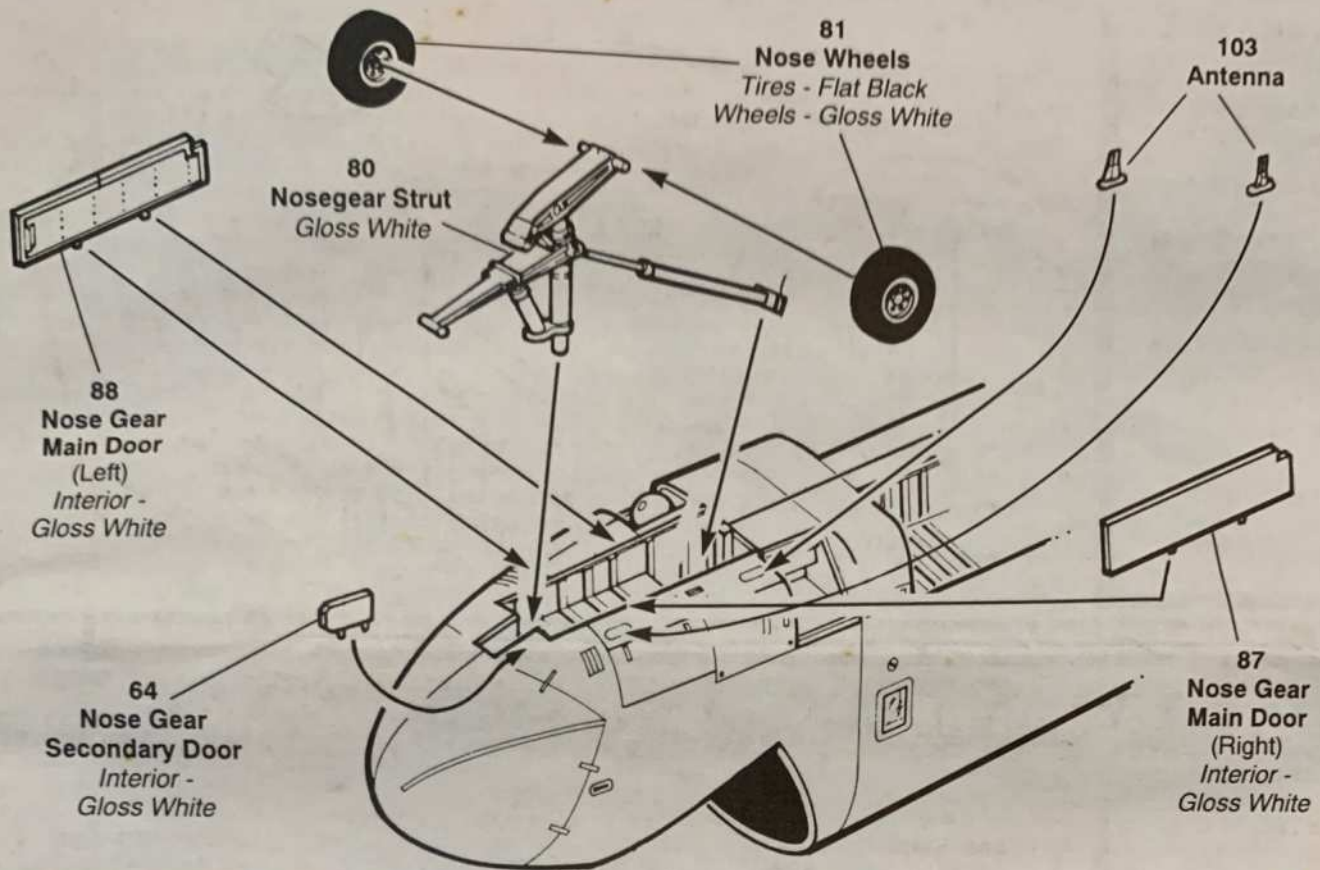

# 6 Bomb Bay Doors

## OPTION 1

**Bomb Bay Doors closed.**

1...Cement DOORS (25, 26, 27 & 28) to fuselage in the closed position. Omit Step 7.

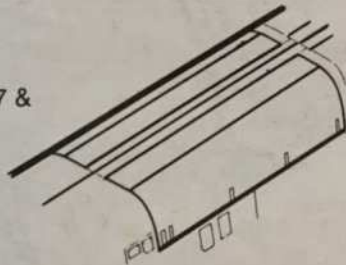

## OPTION 2

**Bomb Bay Doors open.**

1...Cement DOORS (25, 26, 27 & 28) to fuselage.

2...Cement BOMB SHACKLES (4 & 5) to bomb bay roof as shown.



# 7 Bomb Installation

## CONSTRUCTION NOTE:

1...Cement bomb halves together to make four ASW bombs.

2...Cement bombs to shackles in bomb bay as shown.



**ASW Bombs**  
(Left & right halves)  
Light Ghost Gray  
FS 36375

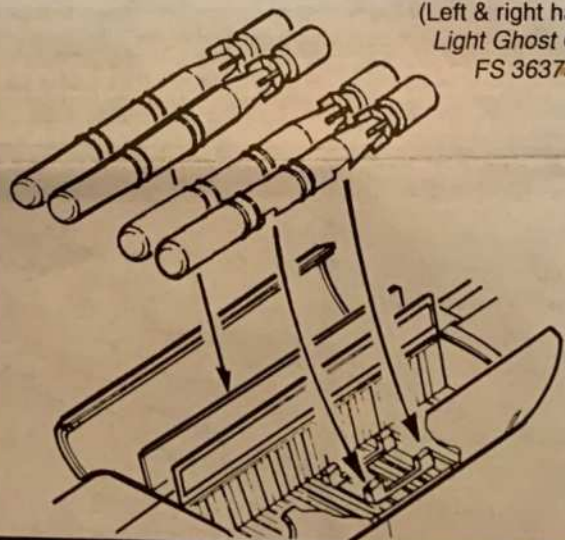

# 8 Main Gear Assembly & Installation

## TIRE/WHEEL ASSEMBLY

Make two of these assemblies.

85 & 86  
Tire & Wheel  
Wheel - Gloss White  
Tire - Flat black



## CONSTRUCTION NOTE:

- 1...Cement TIRE & WHEEL (57, 58) halves together.
- 2...Cement MAIN GEAR STRUTS (63, 65) to GEAR MOUNT BULKHEADS (15, 16)
- 3...Cement ACTUATOR STRUTS (78, 79) to main gear struts as shown.
- 4...Cement tire/wheel assemblies to main struts.
- 5...Cement assemblies into each main gear bay.

## LEFT MAIN GEAR ASSEMBLY

WHEEL & TIRE ASSEMBLY

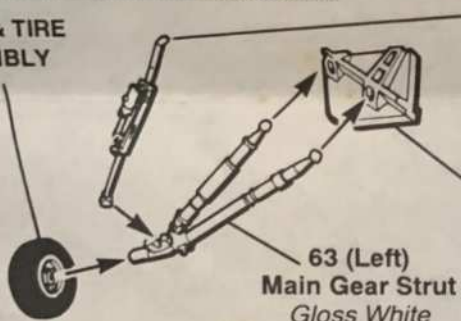

79 (Left)  
Main Gear  
Actuator  
Gloss White

15 (Left)  
Gear Mount  
Bulkhead  
Gloss White

63 (Left)  
Main Gear Strut  
Gloss White

## RIGHT MAIN GEAR ASSEMBLY

16 (Right)  
Gear Mount  
Bulkhead  
Gloss White

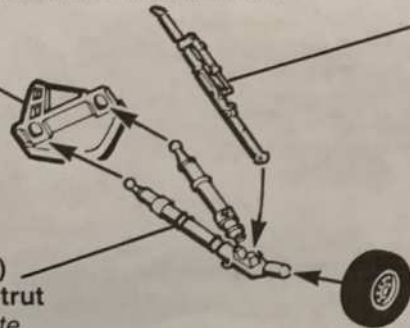

78 (Right)  
Main Gear  
Actuator  
Gloss White

65 (Right)  
Main Gear Strut  
Gloss White

WHEEL & TIRE ASSEMBLY

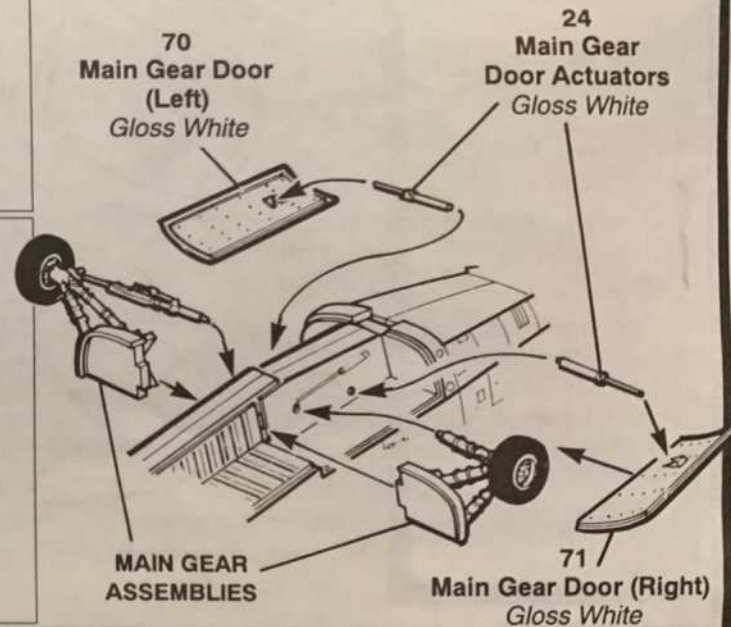

## 9 Empennage Assembly

57 & 58  
Port Stabilizer  
& Elevator  
(halves)

96  
Sonobouy  
Panel  
Gloss White

### CONSTRUCTION NOTE:

1...Cement stabilizer halves together. When dry, cement stabilizers to fuselage. Make sure the stabilizers are supported to maintain the

correct dihedral while they dry.  
2...Cement sonobouy panel to aft underside of fuselage as shown.

61 & 62  
Starboard Stabilizer  
& Elevator (halves)

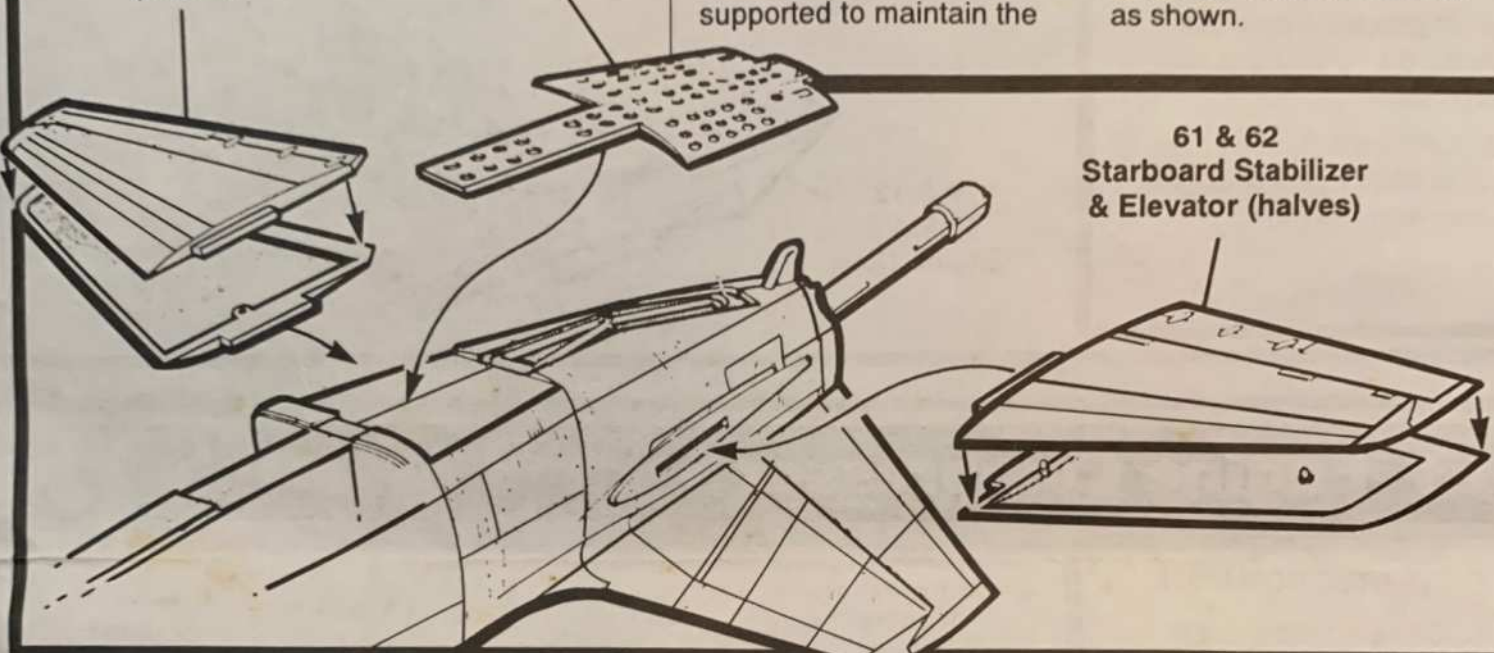

## 10 Lower Main Gear Door Installation

### CONSTRUCTION NOTE:

1...Cement ANTENNAS (103) to FORWARD LOWER DOORS (74, 75) as shown.  
2...Cement Forward Lower Doors and AFT LOWER DOORS (72 & 73) into position.

74 & 75  
Forward Lower  
Main Gear Doors  
Interior - Gloss White

72 & 73  
Aft Lower Main  
Gear Doors  
Interior - Gloss White

103  
Antenna  
(Both doors)  
Black

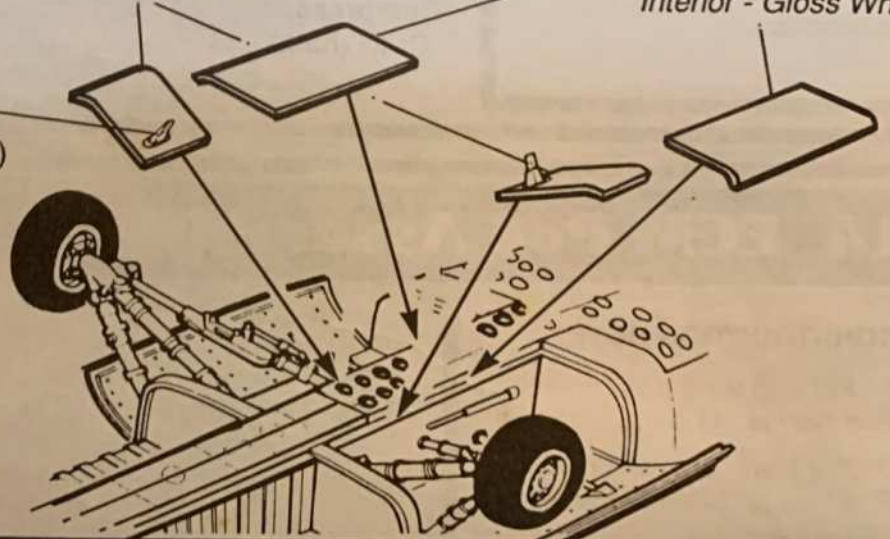

# 11 Wing Assembly

## CONSTRUCTION NOTE:

1...Cement LOWER WING HALVES (55, 60) to UPPER WING HALVES (56, 59).

2...Cement ANTENNAS (103) into position as shown on each wing assembly.

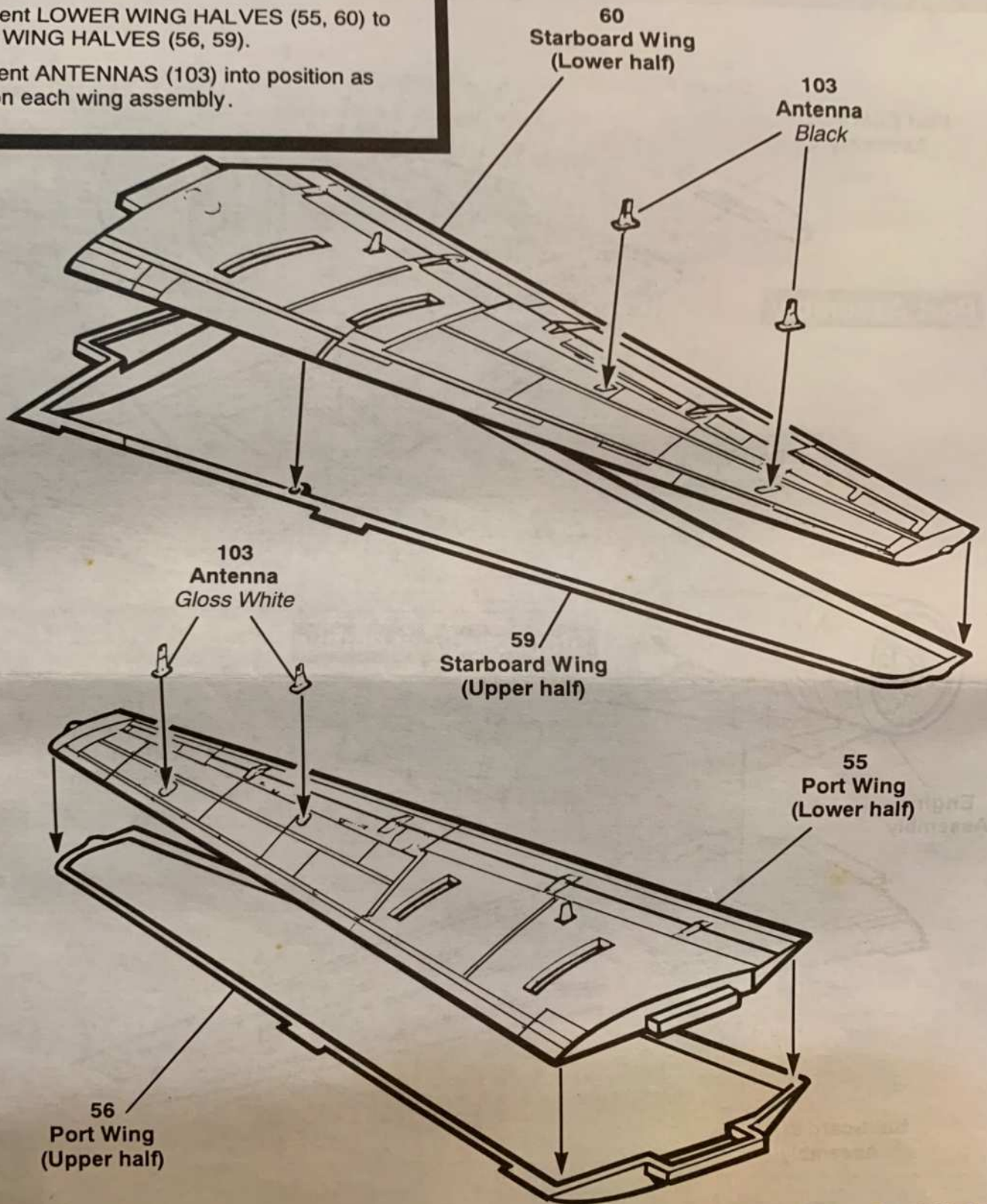

Form No. 099-8634

## 12 Aft Engine Section & Pylon Assembly

### CONSTRUCTION NOTE:

1...Cement Exhaust Turbine Wheels (6) into position on each left Pylon & Engine Cowl (10, 11).

2...Cement left and right Pylon & Engine Cowl halves together.

3...Cement a Bypass Fan (2) to each Pylon & Engine Cowl assembly.

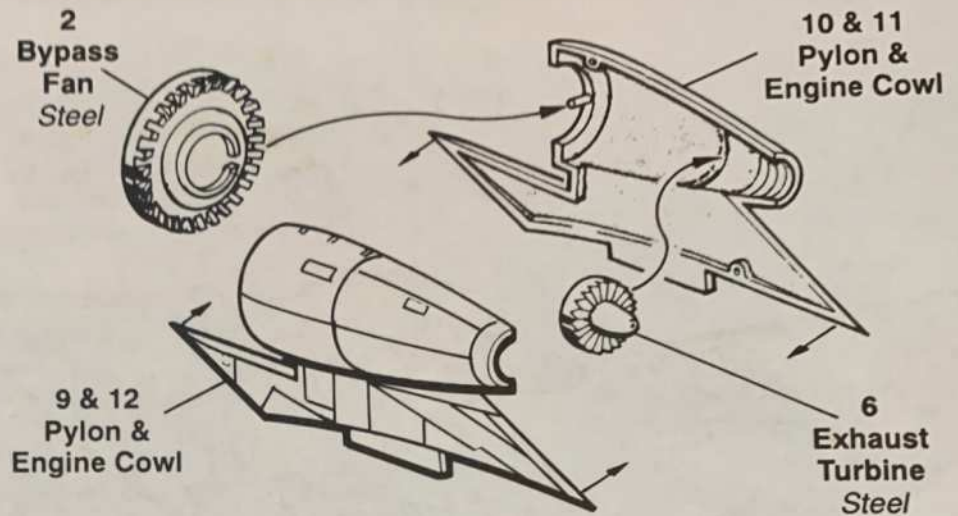

## 13 Engine Compressor Section Assembly

### CONSTRUCTION NOTE:

1...Cement Compressor Turbine (3) to the left Cowl (18, 20).

2...Cement each Compressor Cowl & Compressor Turbine assembly to a Pylon & Engine Cowl Assembly.

3...Cement remaining Cowl halves (17, 19) to the Engine Cowl/Pylon assemblies.

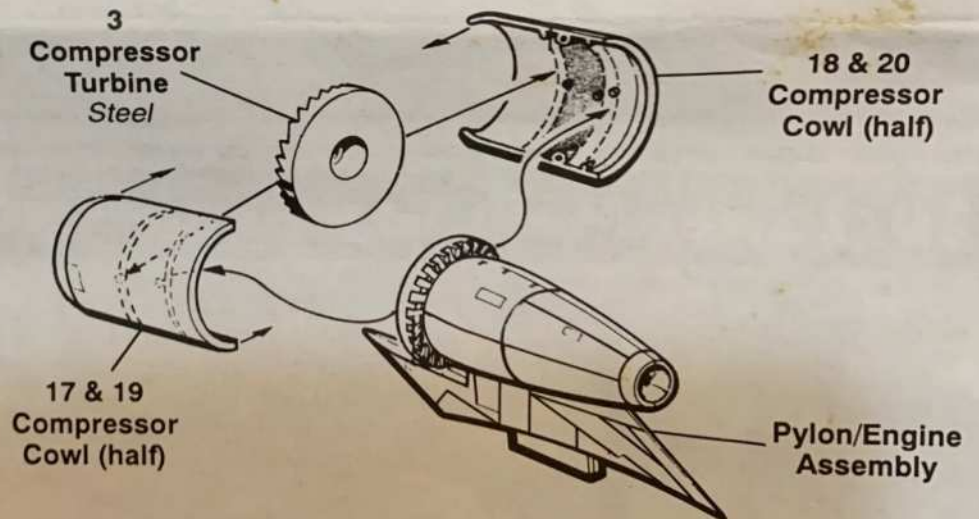

## 14 ECM Pod Assembly

### CONSTRUCTION NOTE:

1...For port wing pod cement Pod halves (44 & 43) together.

2...For starboard wing cement Pod halves (53 & 54) together.

44 & 53  
ECM Pod  
Ends - yellow  
Body - Light Gray

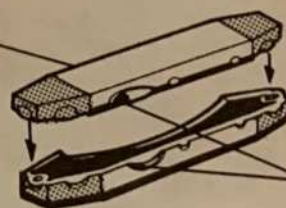

43 & 54  
ECM Pod  
Ends - yellow  
Body - Light Gray

Navigation Lights:  
Port wing: Red  
Starboard wing: Green



# 15 Engine, Pylon, ECM Pod Installation

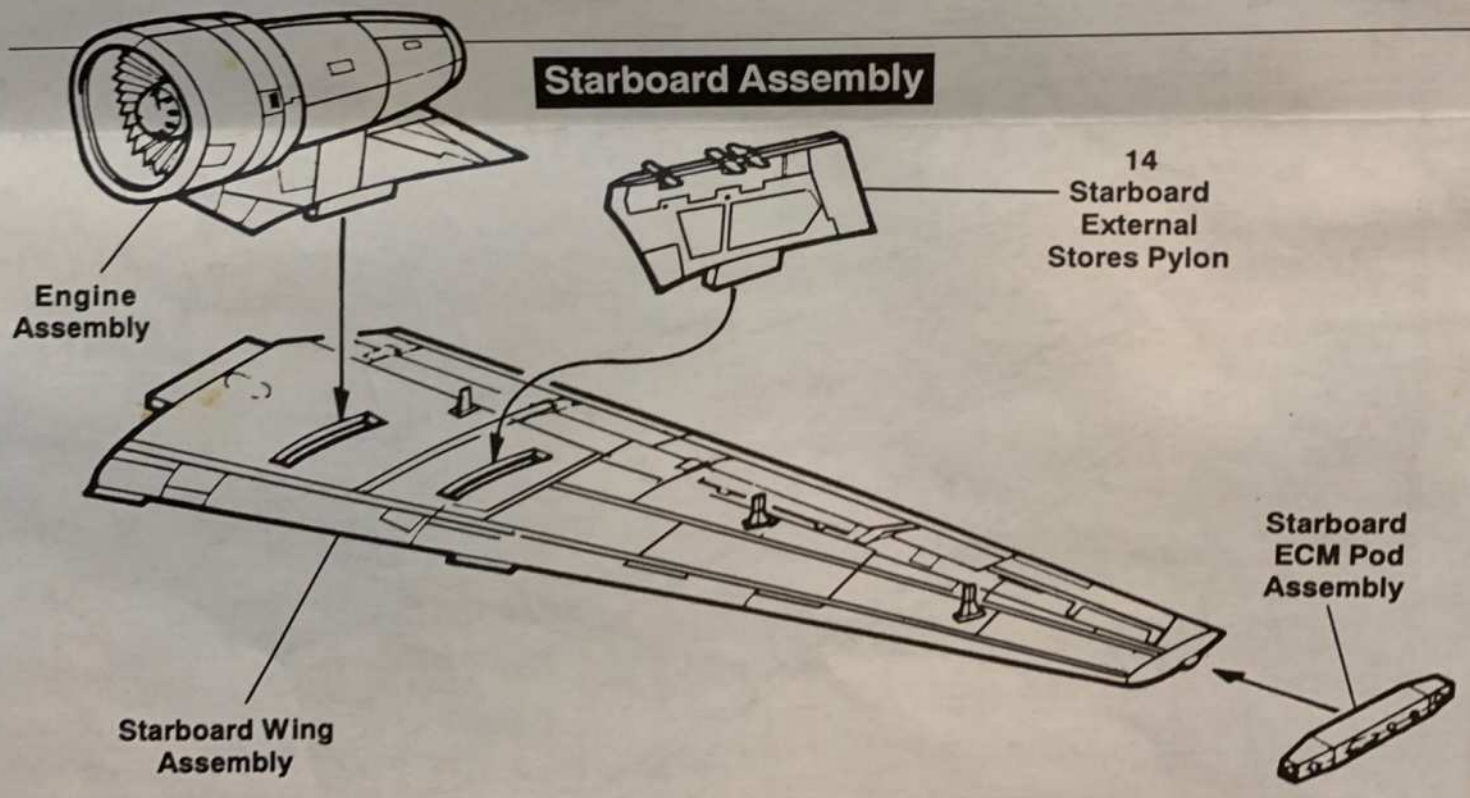
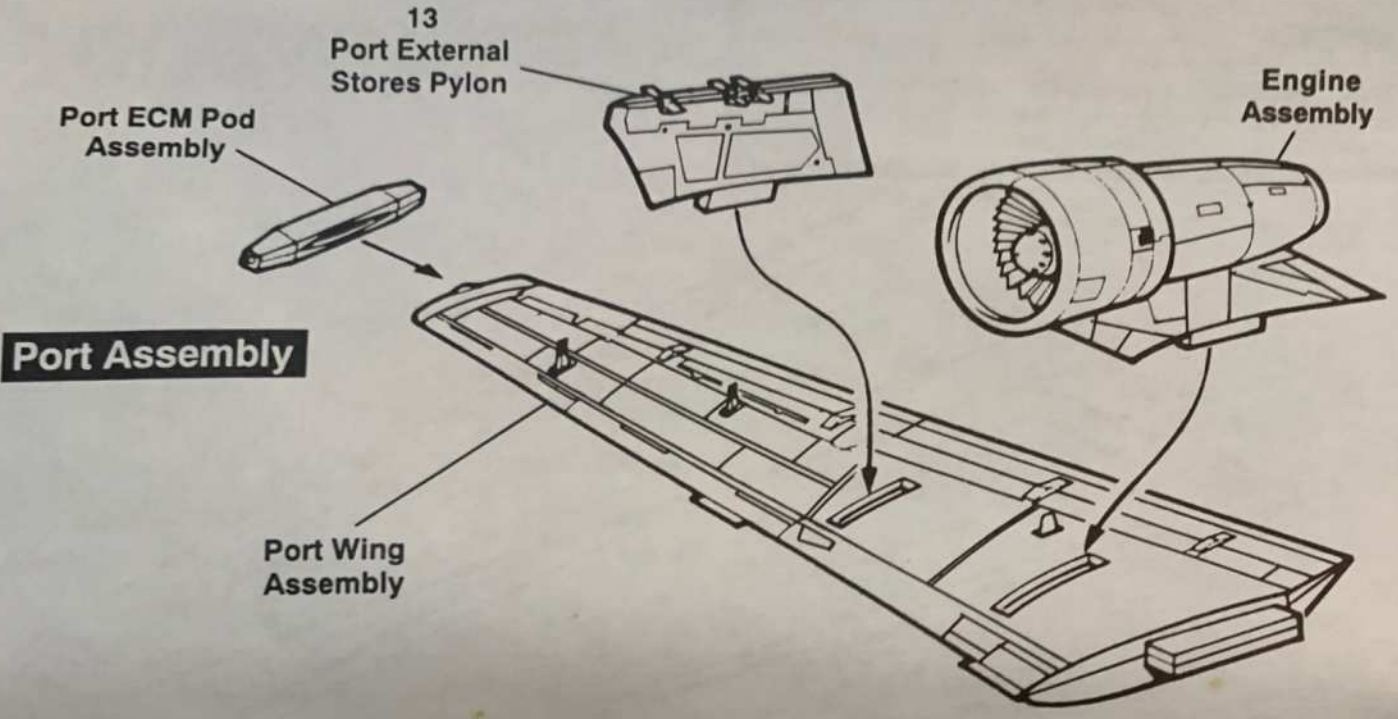

## 16 Cockpit Interior Assembly

### CONSTRUCTION NOTE:

1...Paint all parts Dark Gull Gray FS36231

2...After applying decals 47, 48 & 49, cement Upper Control Panel (84) to Cockpit Rear Bulkhead (36).

2...Apply decals 2, 3 & 4; cement Cockpit Floor & Consoles (37) to Rear Bulkhead assembly.

3...Cement Control Sticks (83) into position.

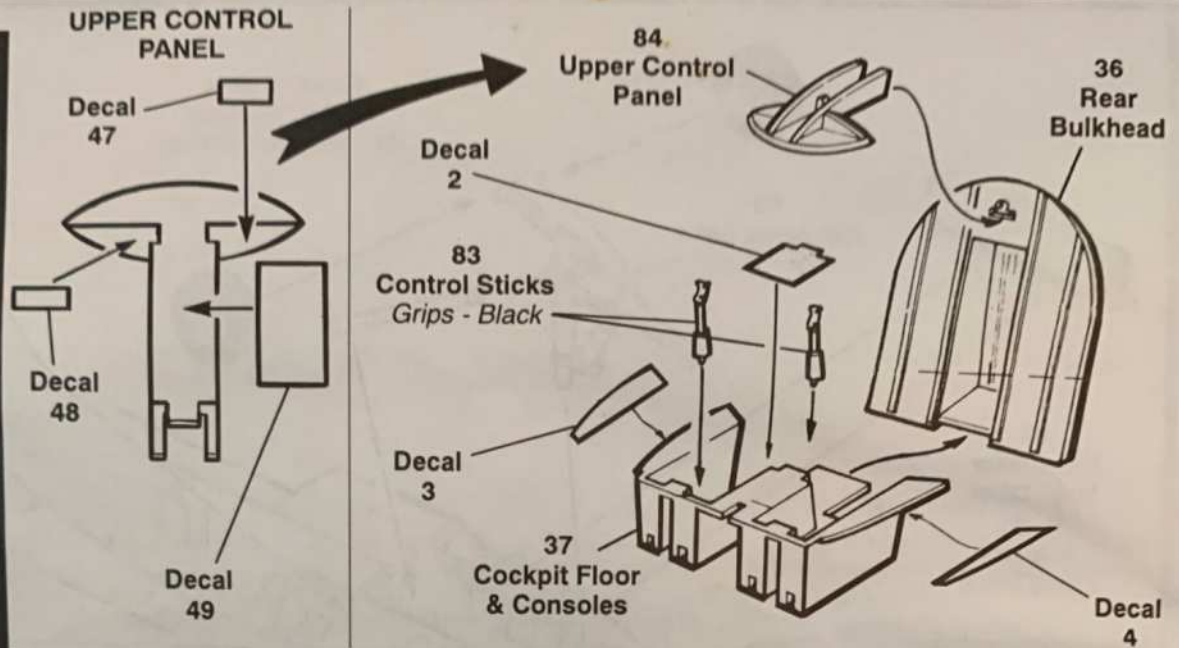

## 17 Seat Assembly

### CONSTRUCTION NOTE:

1...Assemble the pilot's and co-pilot's seats by cementing the Seat Sides (66, 67) and the Seat Sides (68, 69) to the Seat Frames & Pads (76, 77).

2...Cement an Ejection Handle (82) to the top of each seat.

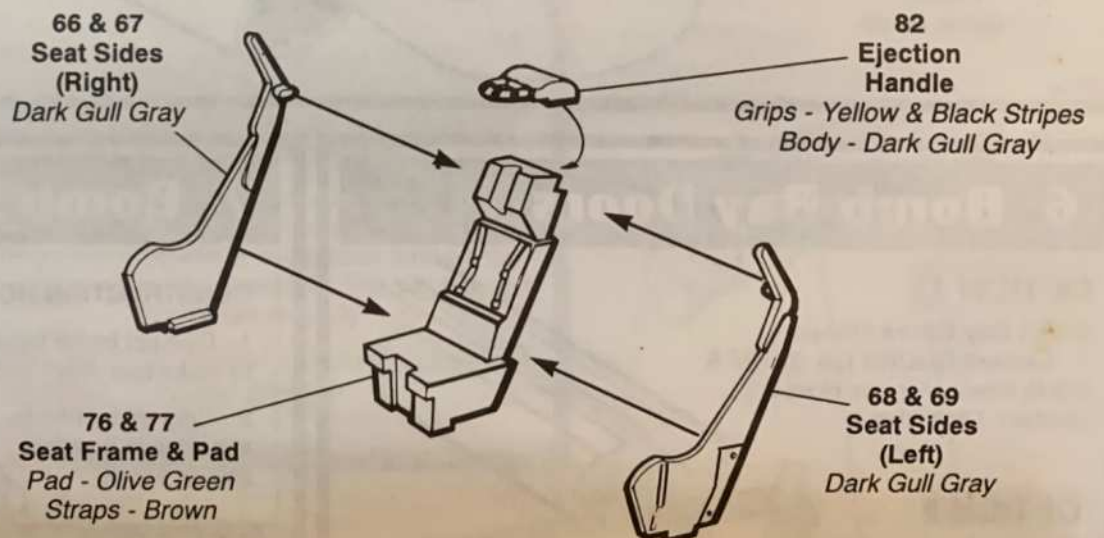

## 18 Seat & Instrument Panel Installation

### CONSTRUCTION NOTE:

- 1...Apply decals 1, 5, & 6 to the Instrument Panel (39)..
- 2...Cement the Instrument Panel (39) and Seat Assemblies to Cockpit Assembly.

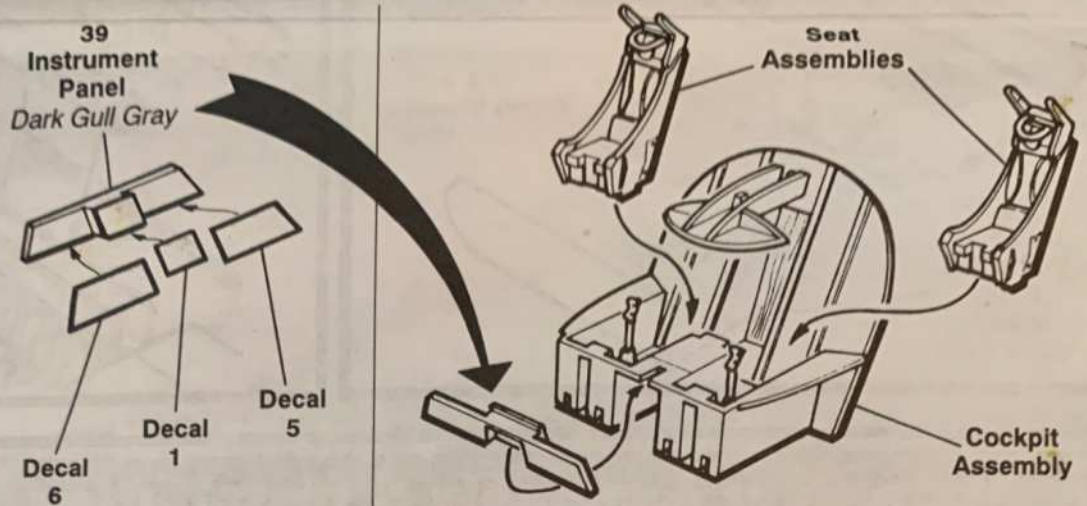

## 19 Wing, Cockpit, Refueling Probe Installation

### CONSTRUCTION NOTE:

- 1...Cement Cockpit Assembly into fuselage.
- 2...Cement Wing Assemblies to fuselage as shown. Support wings at the correct angle until they dry.
- 3...Cement the Instrument Panel Top (23) into position.
- 4...Cement Refueling Probe (22) into position.
- 5...Cement the Instrumentation Probes (42, 29) on each side of fuselage as shown.

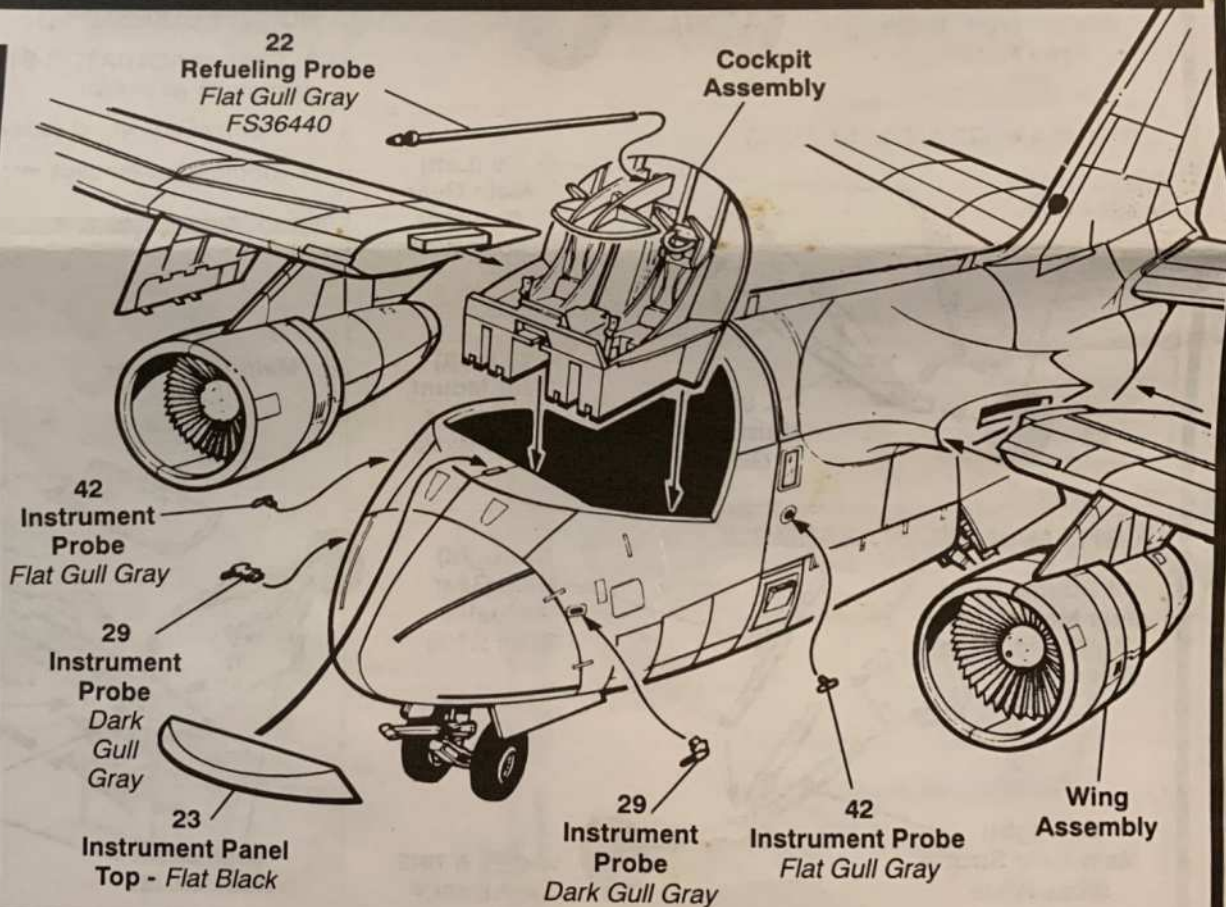

## 20 Missile Assembly

### CONSTRUCTION NOTE:

- 1...Cement missile halves (101,102) together.
- 2...Cement Fins (98,99) to missile body.

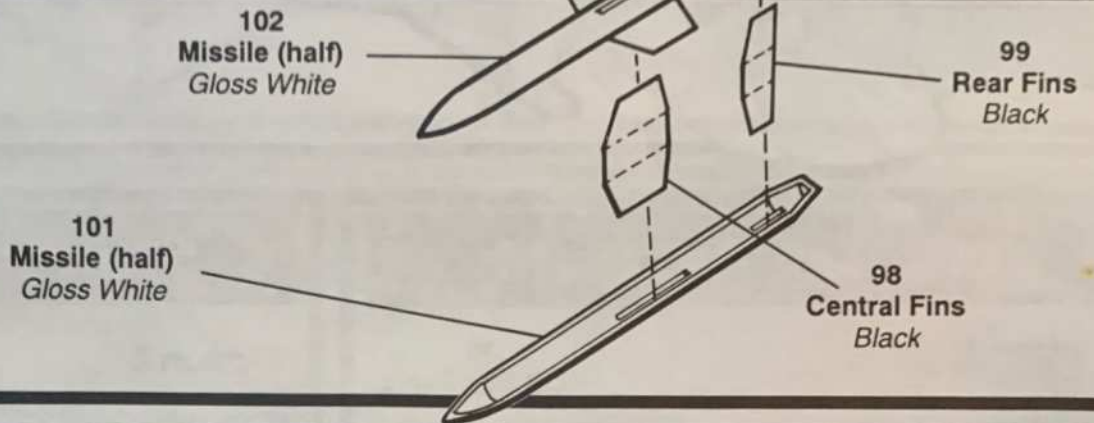

## 21 Canopy , Weapons Installation

### CONSTRUCTION NOTE:

- 1...Cement Canopy (104) to fuselage.
- 2...Cement Probe Hatch (105) to canopy.
- 3...Cement Windshield Wipers (33,34) to fuselage.
- 4...Cement missile assemblies to weapons pylons.
- 5...Cement Antenna (41) to top of fuselage

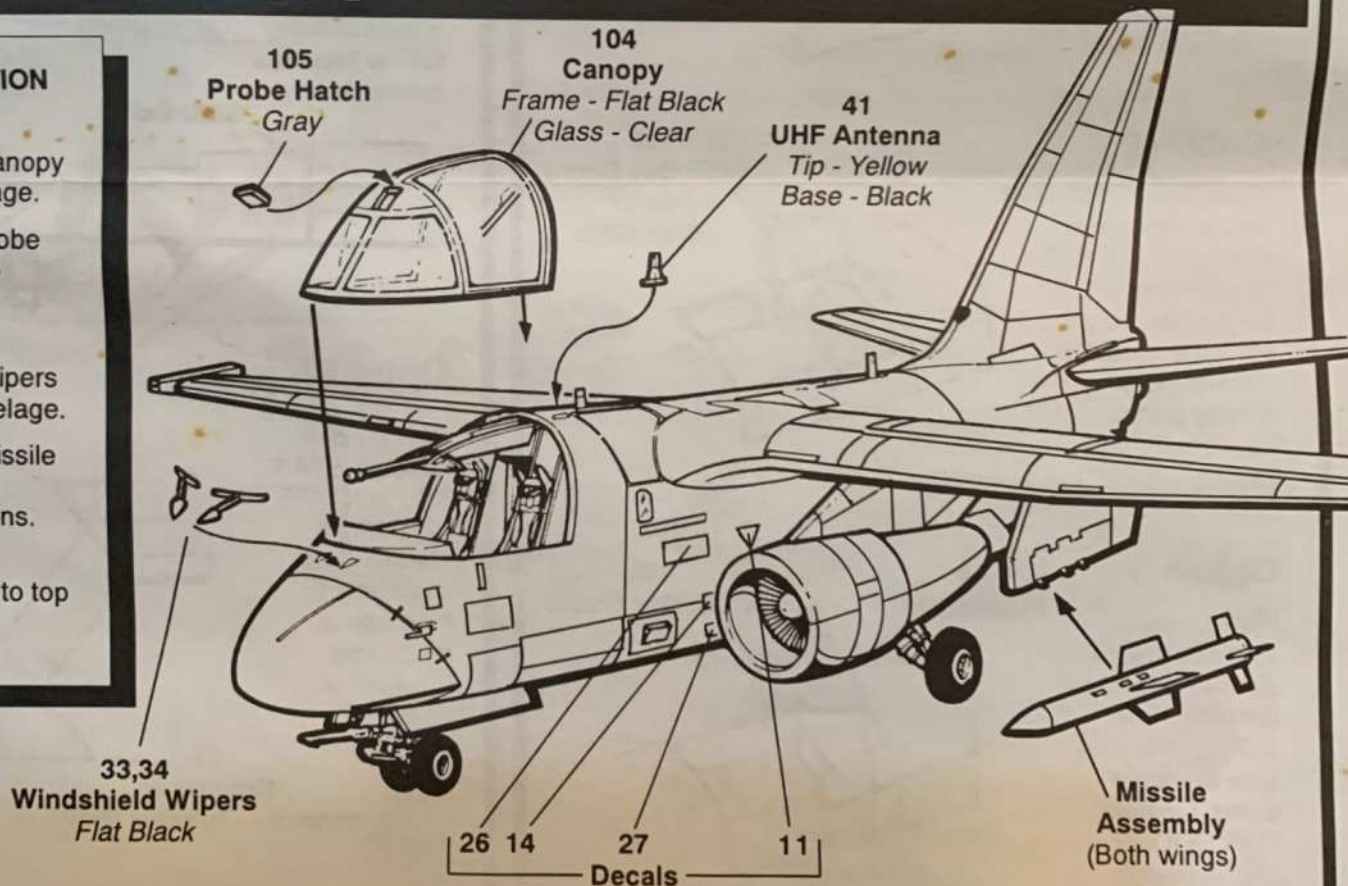

STOCK No. 8634

FORM No. 099 - 1185

LOCKHEED S-3A

# Viking

## SUBMARINE HUNTER / KILLER



### IMPORTANT

Before you begin to assemble your model kit, study the instructions carefully. This will help you to familiarize yourself with the part locations as you proceed. Prior to cementing parts together, be sure to "TEST FIT" them in order to assure proper alignment and also to check for excess "FLASH" that may occur along parting lines. Use a sharp hobby knife or file to remove flash if necessary.

If you wish to paint your model, various sub-assemblies and components should be painted before any parts are attached.

During assembly, you may note that the recommended color is stated after the part name.

This model kit is molded from the finest high-impact styrene plastic. Use only paints and cements which are specifically formulated for styrene. Read all labels and warnings carefully.

Because the cement will only adhere to bare plastic, it is necessary to remove any paint or "plating" from the area to which the cement is to be applied.

### BUILDING TIPS FOR THE ADVANCED MODELER

*For the best possible finish, your kit should be painted, even if molded in color. Paint should be applied evenly, in several thin coats rather than one heavy coat. The first coat should not completely cover the surface. Each layer should be allowed to thoroughly dry before the next is applied.*

It is important to keep your hands clean when working with your model and wash parts thoroughly before painting to remove any mold release agent that may have been used during manufacture, body oil from your hands, sanding residue, and dust, which is naturally attracted to plastic by static electricity. Use a mild solution of dishwashing detergent and water. A tack rag should be used to dry the parts, DO NOT use paper towels or tissues, since they will leave lint on the part.

Parting lines and glue joints should be sanded or filed prior to painting. Because paint has a tendency to draw away from sharp edges, they

should be lightly filed. Use filler putty designed for plastic to fill small gaps that may occur between parts and to blend contours. This should be done only after the first, or "primer," coat of paint is applied.

When painting a multi color scheme, the lightest color should be painted first. Use frosted, or "magic," tape to mask off the area you do not want painted. After the second color is dry to the touch, the tape can be removed. Use a very fine brush to touch up edges if necessary. If decals are to be added, do so before adding any gloss coat. A gloss coat will help even out the edges between the two colors as well as set the decals.

NOTE: Federal standard colors The military services use standardized colors, each receiving a specific five digit identification number. Grays, for instance, are all 6000, and gloss paints begin with a 1, semi-gloss 2, flats 3. Thus a gray color can be gloss ( 16251 ), semi-gloss ( 26251 ) or flat ( 36251 )

### RECOMMENDED TOOLS

#### HOBBY KNIFE

Use a sharp hobby knife to remove parts from the trees. The knife may also be used to remove parting lines and flash.



#### TWEEZERS

Use tweezers to hold small parts during assembly, painting and when applying cement.



#### BRUSH

We recommend the use of liquid polystyrene cement. Apply with a fine brush. Use sparingly or a sloppy job will result.



### READ ALL LABELS AND WARNINGS CAREFULLY

We take great pride in providing the finest model kits available, giving strong attention to detail and craftsmanship. Should you have any difficulty with assembly or missing parts, please call the appropriate number listed below between the hours of 8:00 am to 4:30 pm central time, Monday through Friday.

In the U.S.A. call toll free

800 - 553 - 4886

Outside of the United States call

1 - 319 - 875 - 2000

When in the Midwest, please visit the ERTL Company for a tour of the AMT production facilities, 10am & 1pm weekdays. Reservations suggested.

**TOP VIEW**

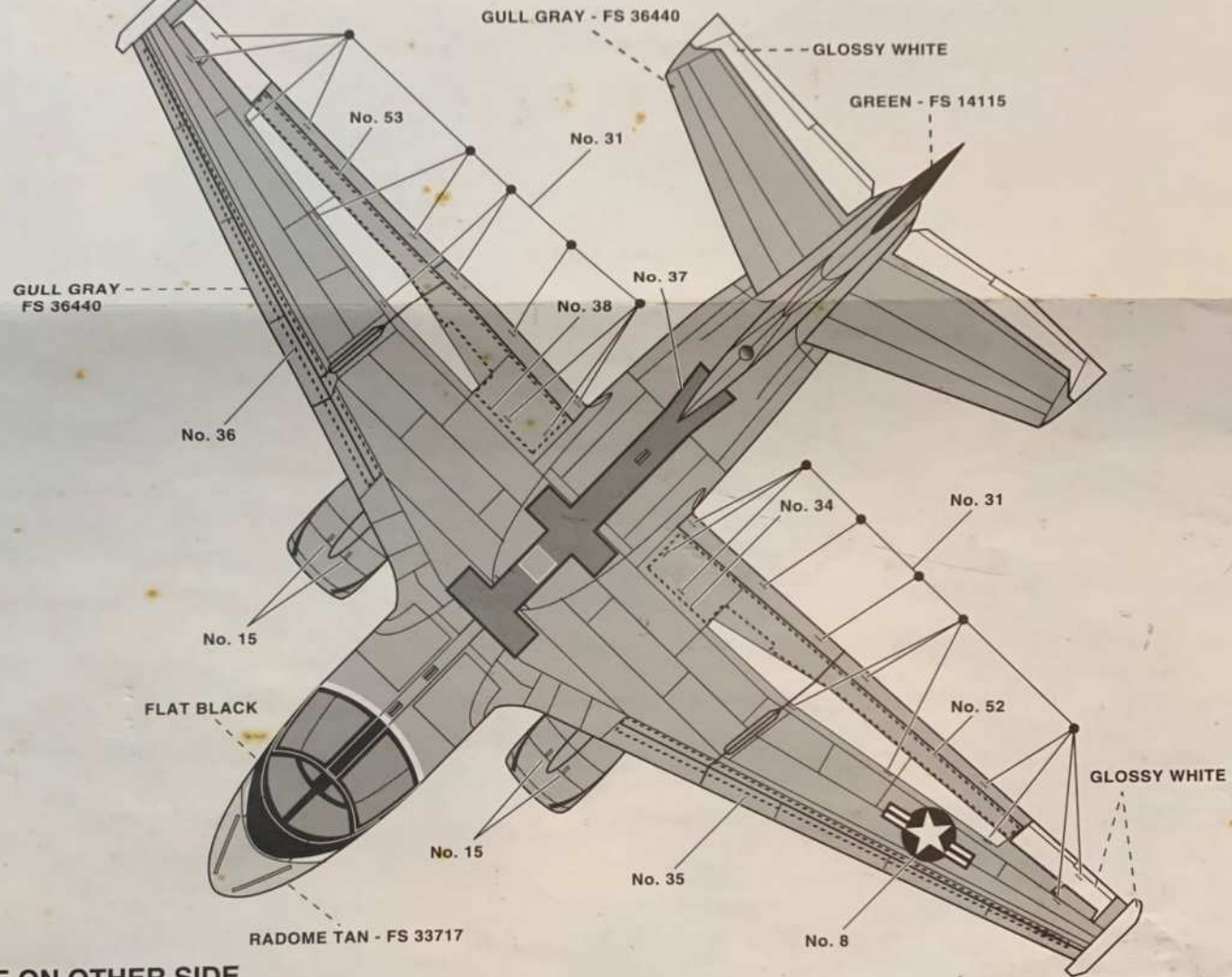

**CONTINUE ON OTHER SIDE**

# LEFT SIDE VIEW

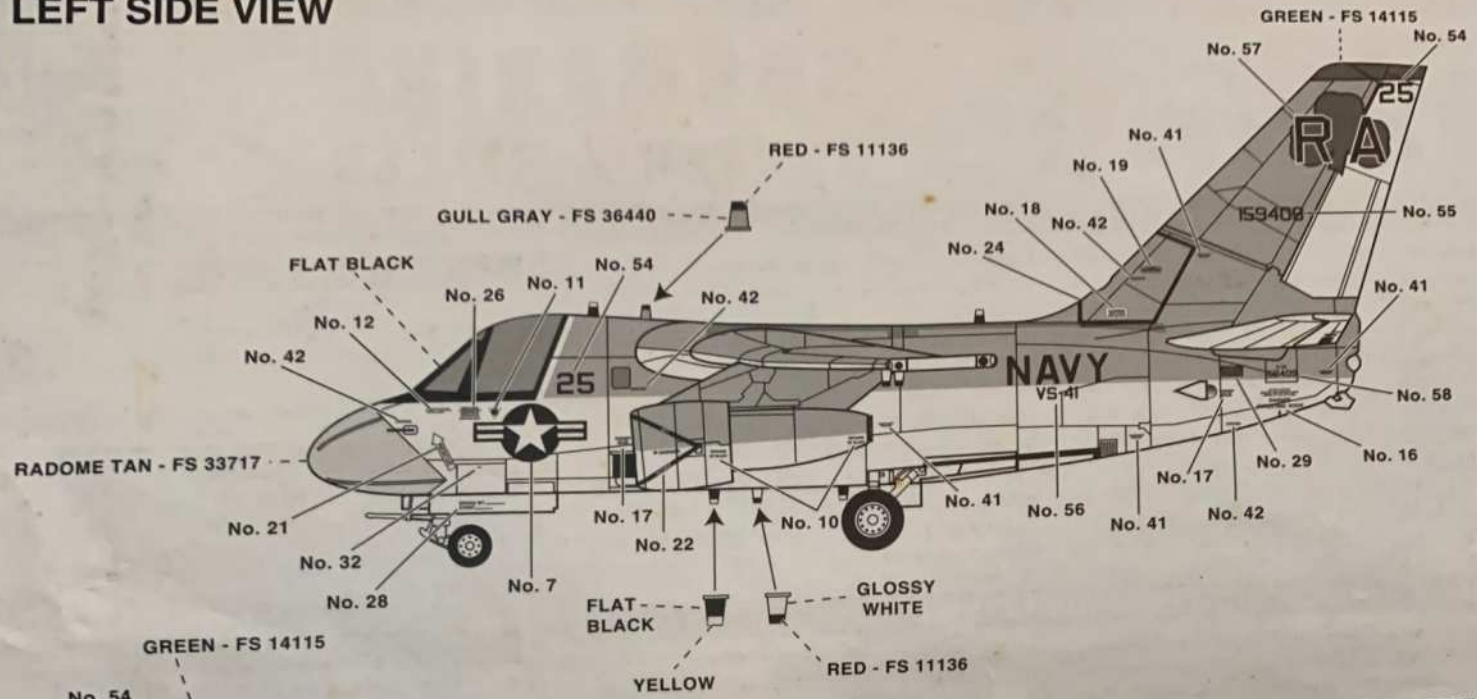

# RIGHT SIDE VIEW

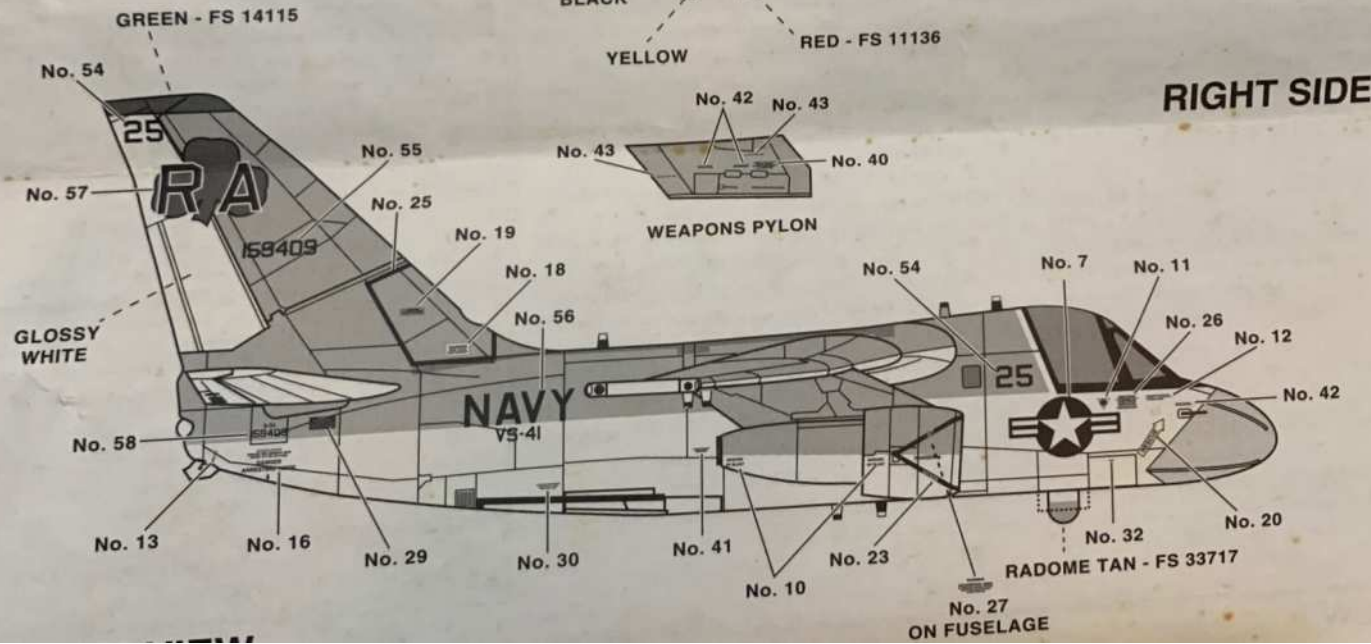

**BOTTOM VIEW**

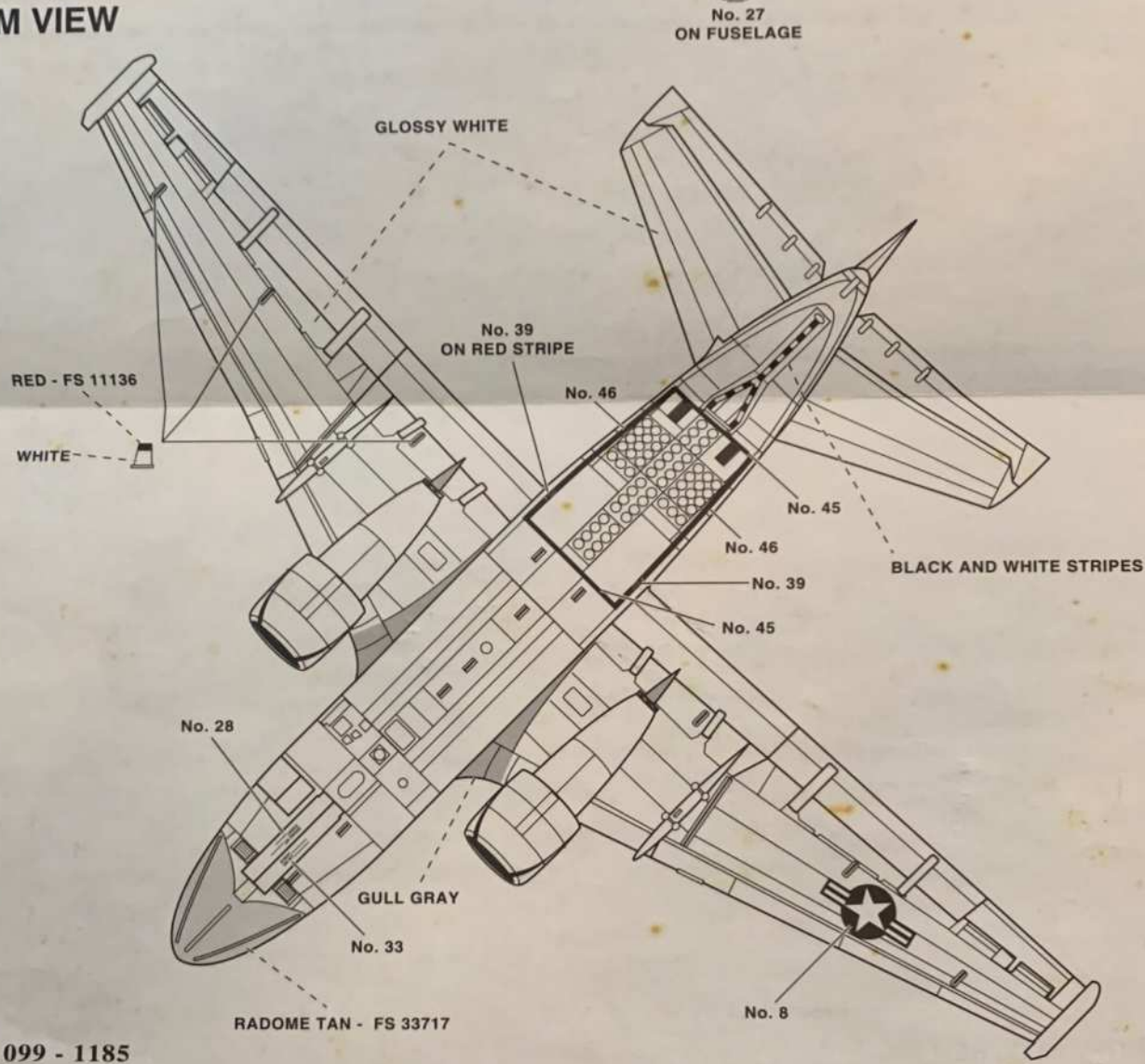

FORM No. 099 - 1185