



Messerschmitt BF 109 D

SW 72005

Scale: 7/72



Messerschmitt BA 109D was one of the most famous fighters of the second world war and actually of the whole history. Type D (DORA) was direct successor of version „B“ and „C“. Development of this type was caused by shortage of engines DB 601. Version „D“ was propelled by a reliable engine JUMO 201 D with adapted exhausts which gave the plane the speed. The aeroplane equipped with electrical equipment which enabled fighting in the night. The armament created four machine-guns MG 17, the other equipment was radio station FUG VII. with only one aerial. The machine had among others arrangement also new spur leg. ME 109 B was produced since autumn 1938 to the end of the same year. Whole quantity (610 pieces) was the biggest from all versions driven by engine JUMO 210. The aeroplanes operated as in Spain (35 pieces) so on the battle fields in whole Europe. Applied was in Poland, Russia, Norway, Slovak etc.

Specifications:

Span:	9,90M
Length:	8,70M
Height:	2,45M
Weight:	2296 kg
Engine:	JUMBO 210 D
Armament:	4x MG 17
Accessible:	9 500 M

Messerschmitt BF 109 D. Jeden z nejslavnějších stíhačů 2. S.V. a historie vůbec. Typ „D“ (DORA) byl přímým pokračovatelem verzí „B“ a „C“. Vznik typu byl způsoben nedostatkem motorů DB 601. verzi „D“ poháněl spolehlivý motor JUMO 210 D, s upravenými výfuky, které zvyšovaly rychlost. Letoun byl vybaven elektrooptickým zaměřovačem, který umožňoval noční stíhání. Výzbroj tvořily čtyři kulomety MG 17. dalším vybavením byla radiostanice FUG VII. s jedinou anténou. Stroj měl mimo jiných úprav i novou ostruhovou nohu. BF109 D byl produkován od podzimu 1938, do konce téhož roku. Celkové množství (610 ks) bylo nejvyšší ze všech verzí poháněných motorem JUMO 210. Letouny operovaly jak ve Španělsku (35 ks), tak na bojištích v celé Evropě. Nasazen byl v Polsku, Rusku, Norsku, Slovensku atd.

Technické údaje:

Rozpětí:	9,90M
Délka:	8,70M
Výška:	2,45M
Váha:	2296 kg
Motor:	JUMBO 210 D
Výzbroj:	4x MG 17
Dostup:	9 500 M

Messerschmitt BF 109 D

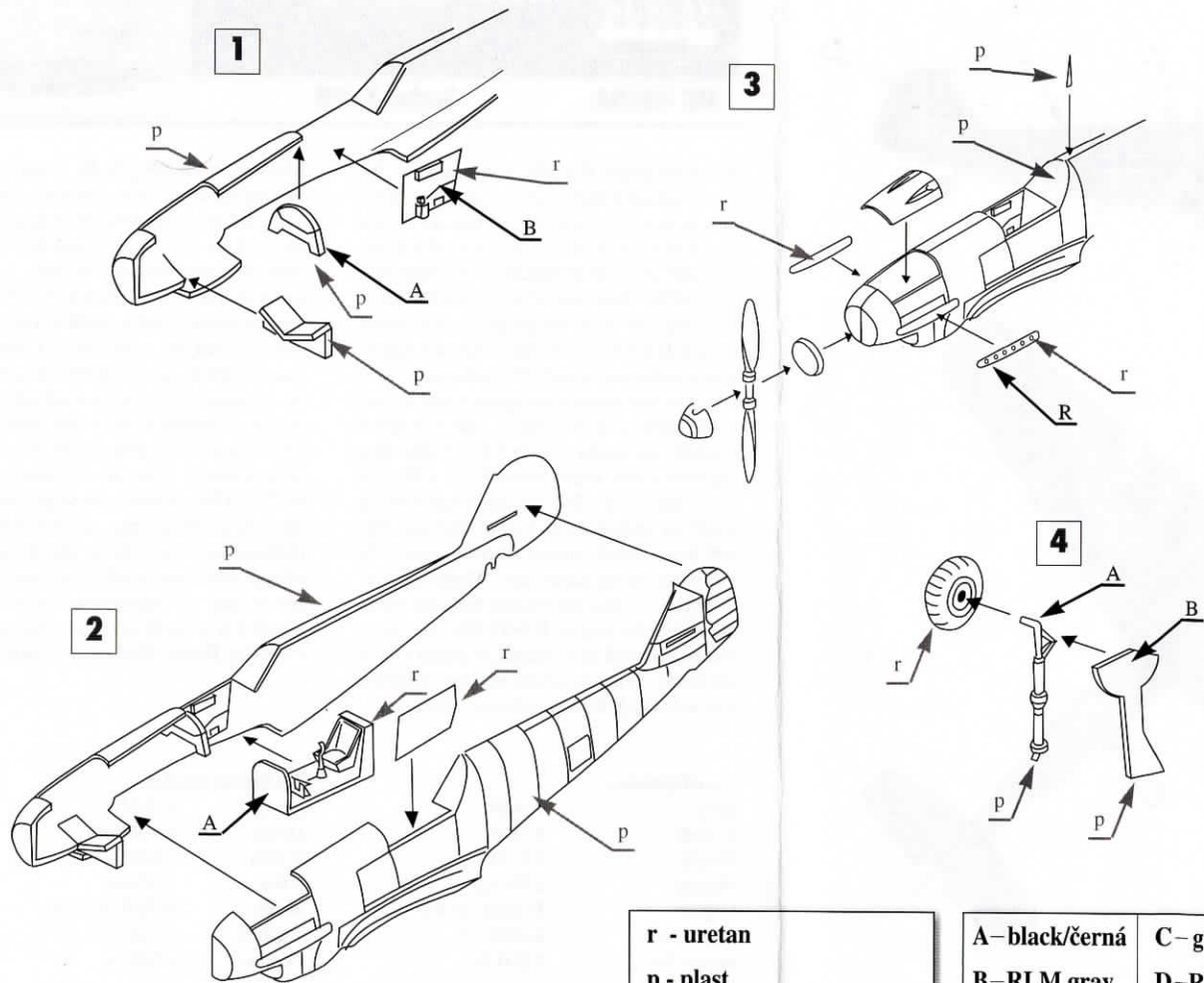

r - uretan
p - plast

A - black/černá
B - RLM gray
C - gum
D - RL

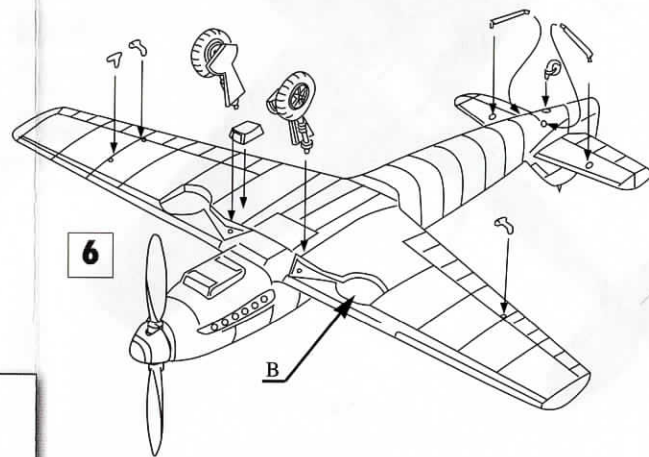
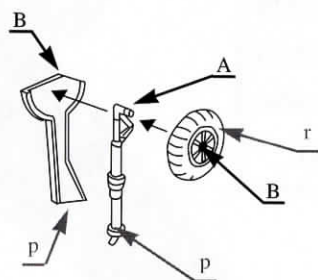
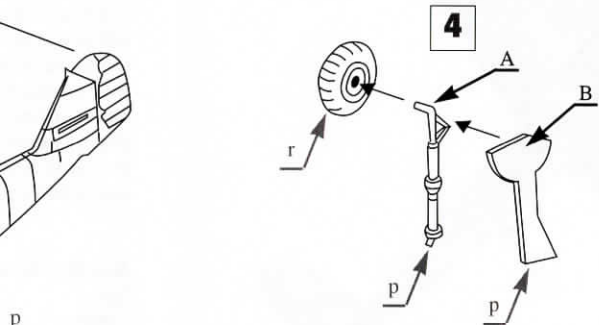
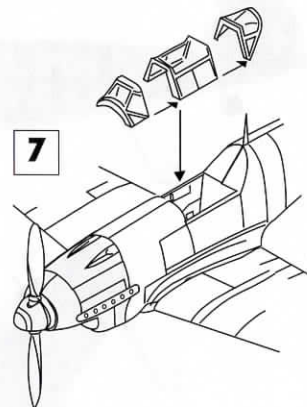
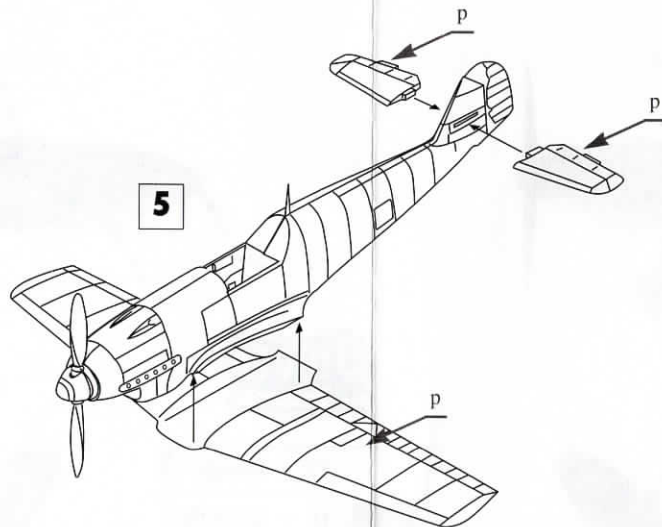
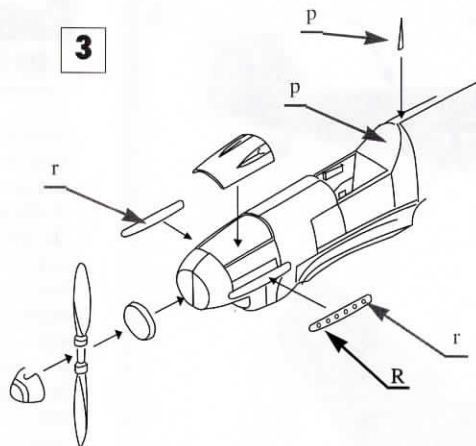

r - uretan
p - plast

A - black/černá
B - RLM gray





C - gun metal/kov
D - RLM 70

E - RLM 71
F - RLM 65

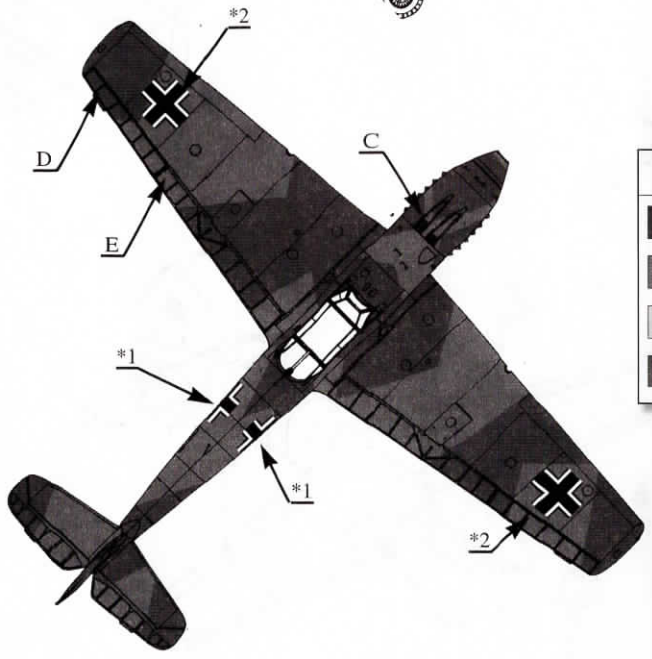
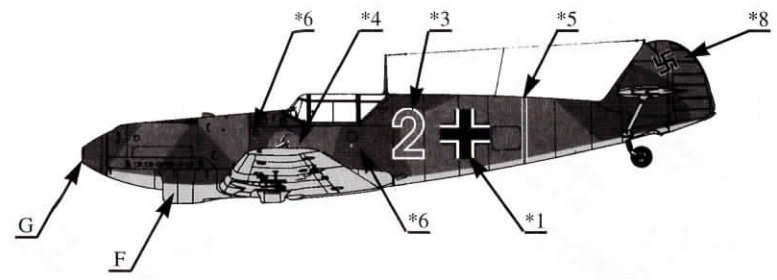
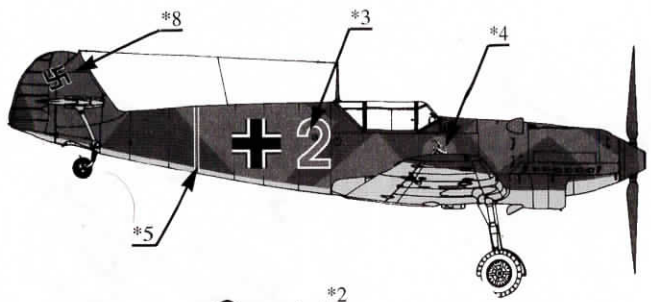
G - red
-

Messerschmitt BF 109 D



*X - Decals	
	D - RLM 70
	E - RLM 71
	F - RLM 65
	G - RED

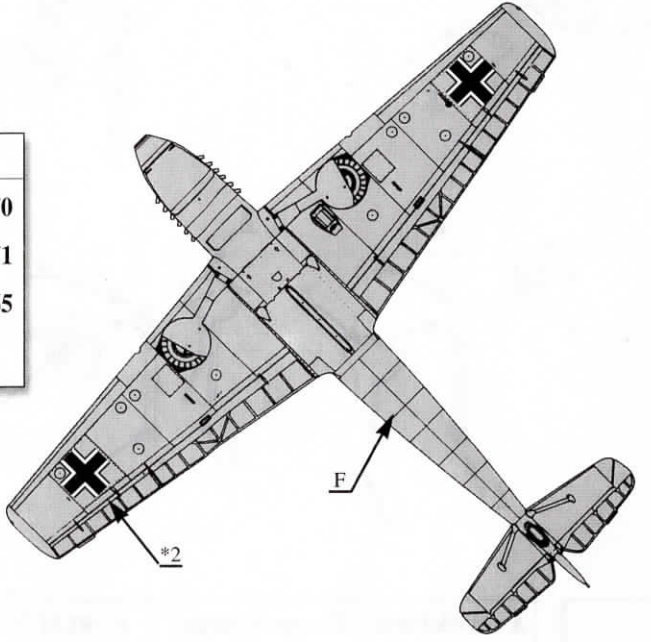



PRINTED BY
mpd

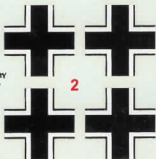

2³ 2



Bf 109D