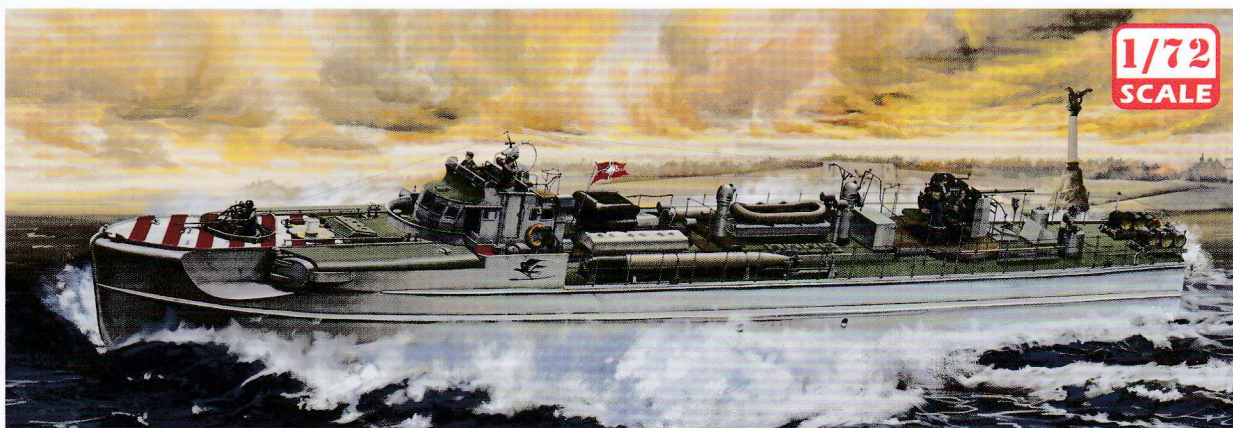

1/72
SCALE

FORE Schnellboot S-38/1942

ITEM 1001

HOBBY

德国S-38级鱼雷艇1942年型

LENGTH 485mm

第二次世界大战期间德国海军鱼雷艇S-38级。英国海军将德军鱼雷艇称为“E-Boat”，E为enemy“敌人”之意。二战德军鱼雷艇多数由不来梅(Bremen)市的吕尔森(Lurssen)船厂建造，轻质合金龙骨木壳艇身圆舳的耐浪外形赋予其良好的远洋作战能力。艇底部尾部的楔形扰流结构可以使圆舳艇体的S艇在高速航行时能抬高艇首，3台和U艇同型的戴姆勒·奔驰公司2200马力的MB511直列12缸液冷12缸引擎赋予S艇约72公里/小时的极速。S艇的主要武器为最大射程12,500米的G7a蒸汽鱼雷。1940年开始服役的S-38级副武器为2门20毫米高射炮，42年起艇尾的20毫米炮被一门40毫米博福斯高射炮取代。

敦刻尔克大撤退时S艇对英法水面舰艇造成了严重打击。1940年6月法国战役结束后，S艇和U艇部队一同进驻位于法国的沿岸基地继续对英作战。41年夏“巴巴罗萨”计划开始，一些S艇拆解后由铁路运输至东线在黑海和波罗的海与苏联海军争锋，同时S艇部队也活跃在北非与意大利战场。41年底美国参战，面对西线盟军强大的海空力量，S艇部队仍频繁由法国基地出击在海峡和北海布雷破交，与皇家海军的快艇，驱逐舰部队及空军激战。43年开始，S-38级开始加装绰号“骷髅头”的舰桥装甲，为操舵室提供额外的10-12毫米装甲防护。这种重防护的新型艇被称之为S-38b级，同时为对抗不断加大的空中威胁加装了雷达探测设备成为战争中后期的主力艇型。

1944年4月27日诺曼底登陆前夕，驻法国瑟堡的第5和第9鱼雷艇支队获取空军侦查情报后于22:00出击，于凌晨1:30在德文郡南部海域的莱姆湾截击了一只美军的登陆演习舰队。S艇艇群的鱼雷突击击沉了两艘满油满弹的LST坦克登陆舰，重创一艘，造成了自珍珠港事件后的美军又一单日伤亡记录。这“仅仅几艘木船”在盟军掌握制空制海权的海域内显示出的作战能力，使得艾森豪威尔将军在内的盟军高层不得不正视其作战能力，盟军战略轰炸机部队也将S艇的基地列为优先打击目标。

二战结束后，部分S艇转入其它国家海军继续服役，一些退役后被改造成工作艇或观光艇在欧洲港口中使用了更长时间。

S-38 Torpedo Boat in German Navy during WWII.

During World War II, the Kriegsmarine manufactured torpedo boats (Also known as S-Boats) at the Lurssen shipyard in Bremen, and Schlichting-Werft in Travemünde. Featuring long-range operational capability, thanks to the application of a light alloy keel, and wooden hull with round bilge. The structure of the wedge spoiler at the stern enabled S-Boats to raise their bows in high-speed sailing. Powered by Three Mercedes Benz MB501 in-line liquid-cooled 12 cylinder engines with a max 2000 HP each, this allowed S-boats to reach a top speed of 72 Km/h. The main armament of S-boats consisted of G7a steam-powered torpedoes, a total of four torpedoes were carried. Two 20mm AA guns at the stern provided secondary armament in 1940 when S-boats began service and eventually replaced by one 40mm Bofors AA gun in 1942.

The surface ships of British and French coalition forces suffered heavy losses by S-boats during the evacuation of Dunkirk. Along with U-boats, S-boats were re-deployed to French coastal bases to combat against the British after the battle of France. Some S-boats were disassembled and transported via railway across Europe to the Black Sea and Baltic Sea and reassembled to join Operation Barbarossa to fight Soviet Union Navy. In the meantime, S-boats were also engaging Allied shipping in the waters off North Africa and Italy. From the end of 1941, S-boats were actively attacking Allied shipping in the English Channel and the North Sea by mine laying.

In 1943, new bridge armour, nicknamed "Skull" was fitted to the S-38 class, providing extra 10-12mm armour protection for the steering room. These upgraded vessels, with additional radar detection devices, were renamed as S-38b class and became the backbone of the torpedo boats fleet in the mid-late period of WWII for the German navy.

On the 28th of April 1944, a day not far away from the planned Allied Normandy Landing, S-boats of No.6 and No. 9 flotillas set off from Cherbourg after obtaining reports from air force reconnaissance and intercepted a US fleet for landing exercise successfully in the sea to the south of Devon. Two LST Tank landing ships, with full fuel and ammunition, were sunk and one was seriously damaged by S-boats' torpedoes. The demonstration of "several wooden boats" in the area where Allied had absolute sea and air superiority made Allied commanders, including Eisenhower, have to take the threat of S-boats into account and list their bases as priority targets for Allied strategic bombers. S-boats continued to serve in other countries after WWII. Among them, some were transformed for working and sightseeing for their extended use at harbours in Europe.

水贴使用说明

1. 将水贴剪下置于温水中浸泡约15秒。
2. 从水中取出水贴，等待图案与底纸自然分离。
3. 将水贴置于恰当的位置，轻轻将水贴印刷面推离底纸至适当位置。
4. 精确调整水贴的位置。
5. 用吸水纸巾或棉签轻轻按压水贴表面，将水份和气泡全部挤出。
6. 待其自然干燥。

Instruction for decal application

1. Cut decals from sheet and soak them into water for 15 seconds.
2. Take decals from water and wait them to separate from base paper naturally.
3. Hold the edge of decals and slide them onto the model.
4. Move decals to proper positions precisely.
5. Press decals down gently with water absorption paper or cotton bud until excess water and air bubbles are gone.
6. Wait decals dry.



注意
CAUTION

在使用胶水组装模型或进行涂装上色的过程中，请保持通风环境。

Keep ventilated when glue or paint was used

南京市极致模型玩具有限公司

中国江苏省南京市江北新区七瑶路7号

Nanjing JiZhi Models & Toys Co., Ltd.

No. 7 Qi Yao Road, Jiangbei New Area, Nanjing China

Tel: +86-25-86518995

E-mail: forehobby@sina.com

www.forehobby.com

零件清单图示 Part List

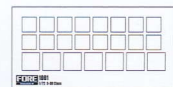
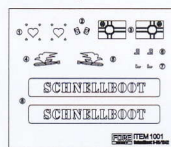
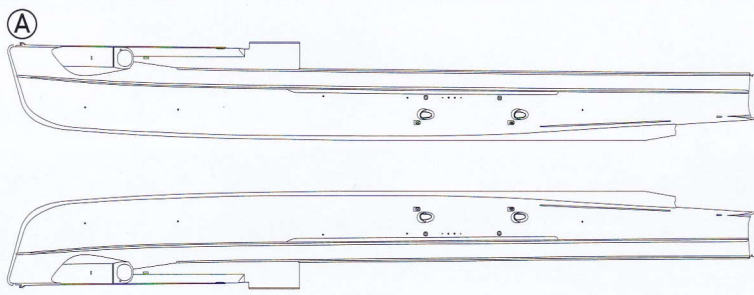

水贴纸
Decal

菲林
Film

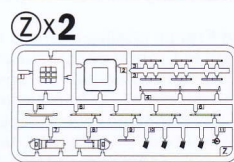
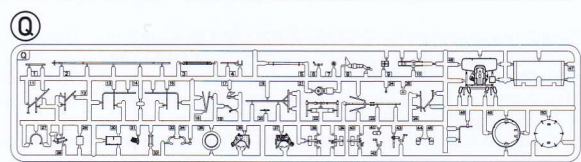
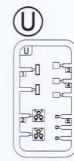
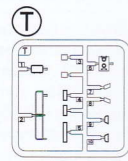
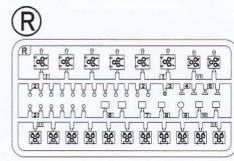
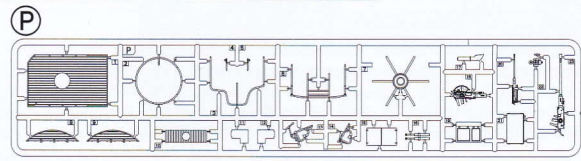
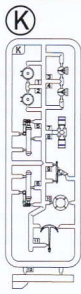
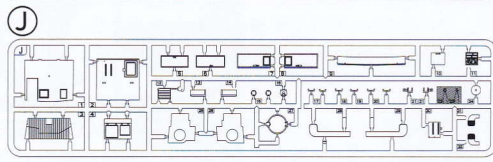
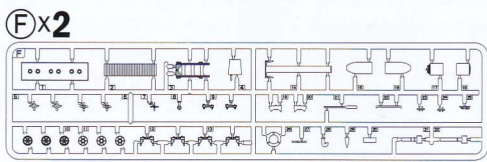
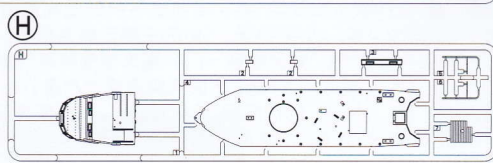
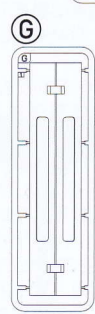
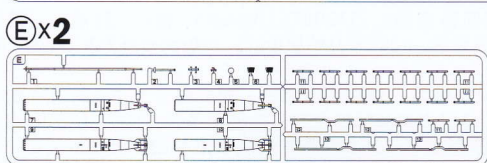
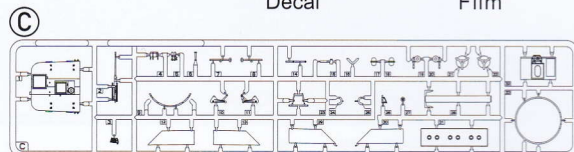
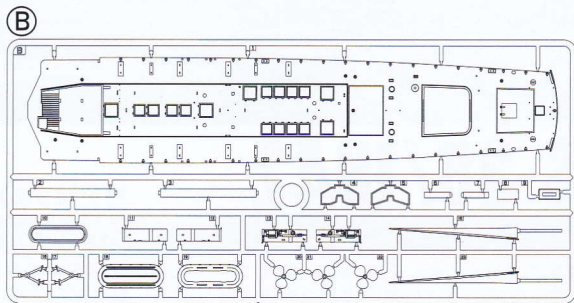

不需要使用的部件
Don't need to use

蚀刻片
Photo-etch



金属丝
Wire
0.2X120mmX2

金属丝
Wire
0.1X300mmX4

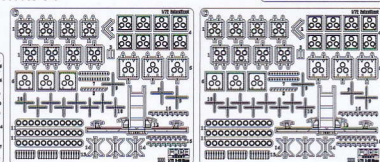
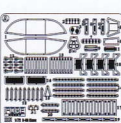
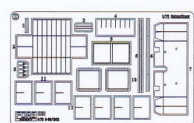

切除阴影部分 remove shaded parts	钻孔 drill	对侧同样制作 make the same for the other side	将孔填平 fill holes	选择制作 options to choose
锉平 file smoothly	x2 制作2组 make two sets	不用黏合 do not cement	使用瞬间胶 use instant glue	注意 attention
A1 塑料零件编号 codes for plastic parts	A2 蚀刻片编号 codes for photo etched parts	16 过往步骤 previous steps	A1 被取代的零件编号 codes for replaced parts	C35 郡士油性漆 Gunze nitrocellulose lacquer

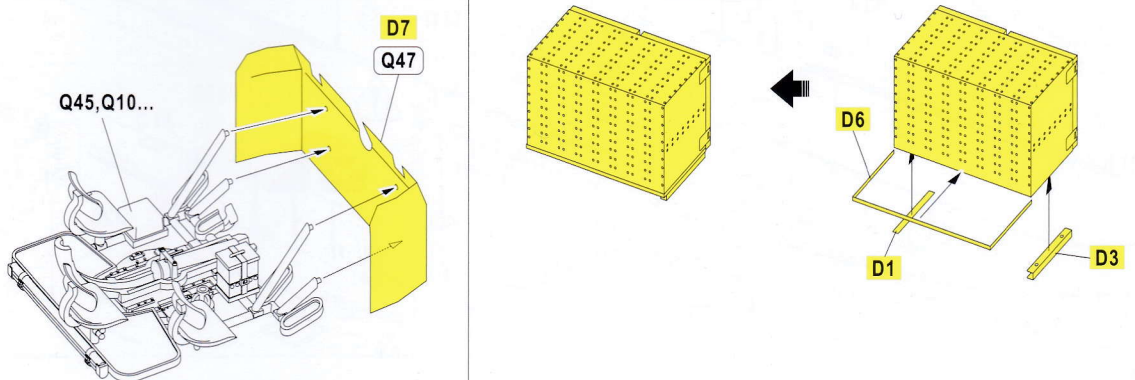
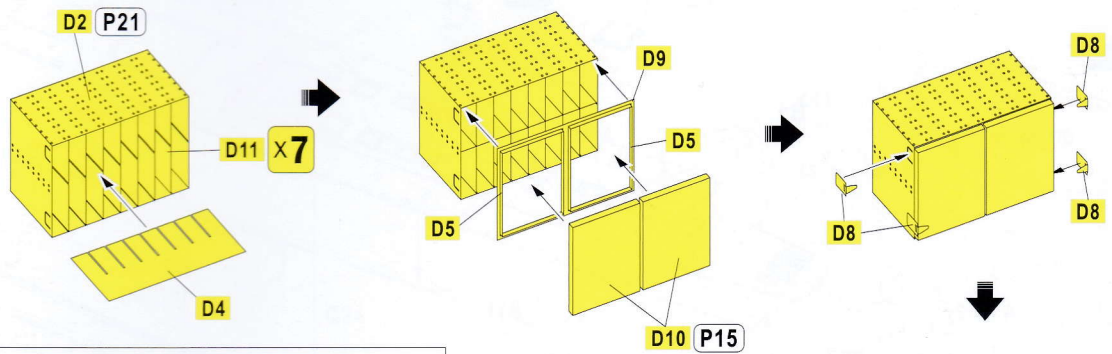
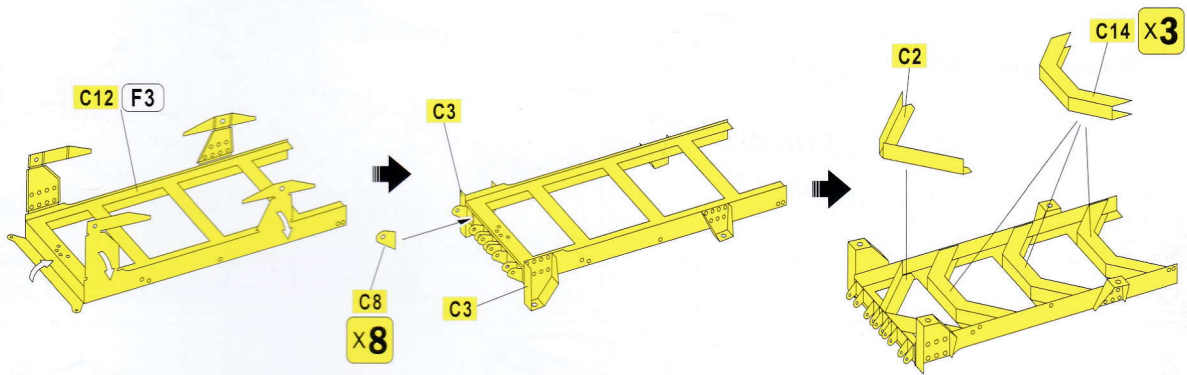
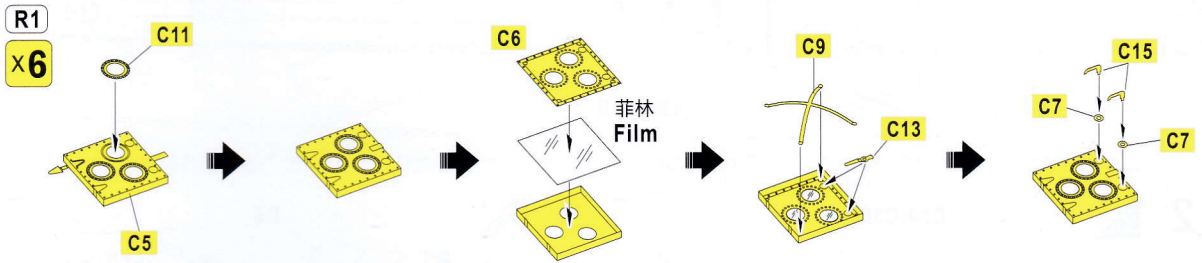
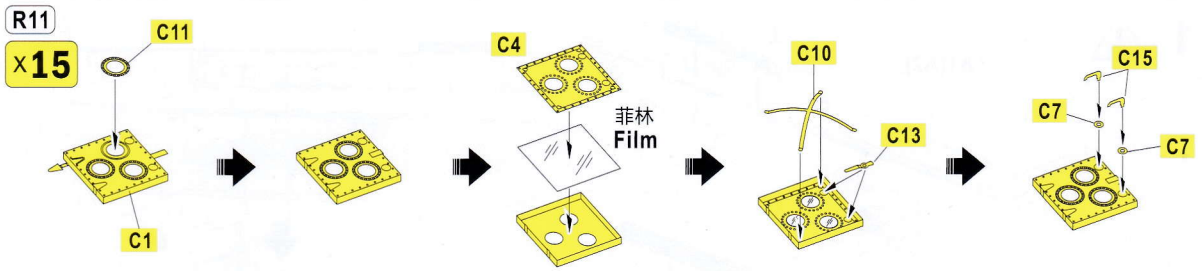

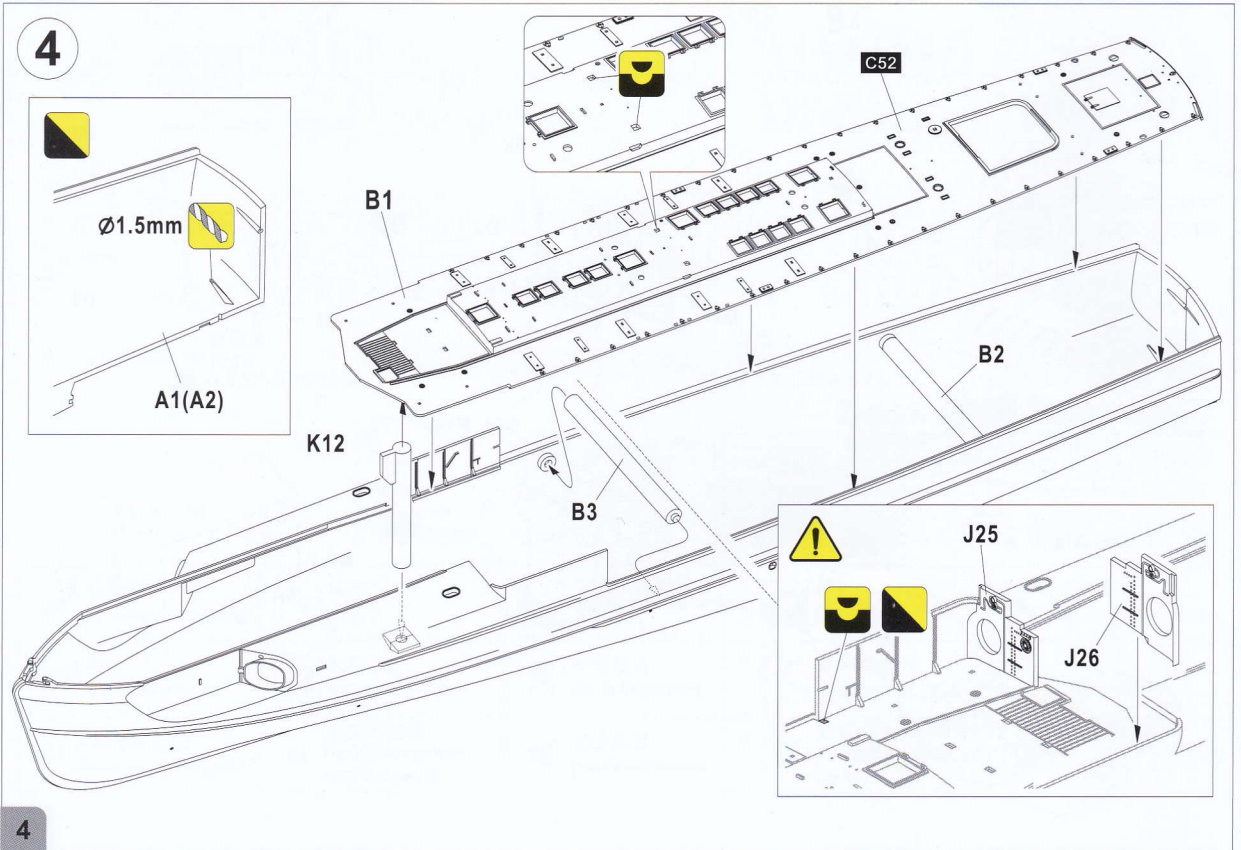
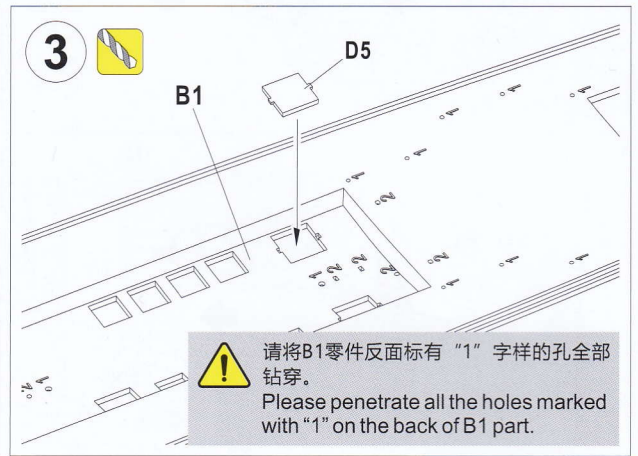
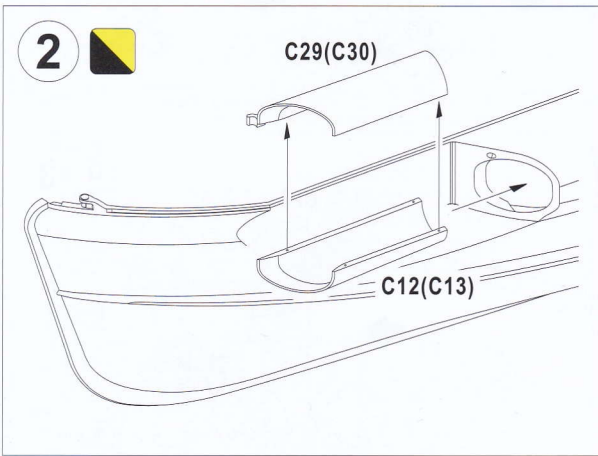
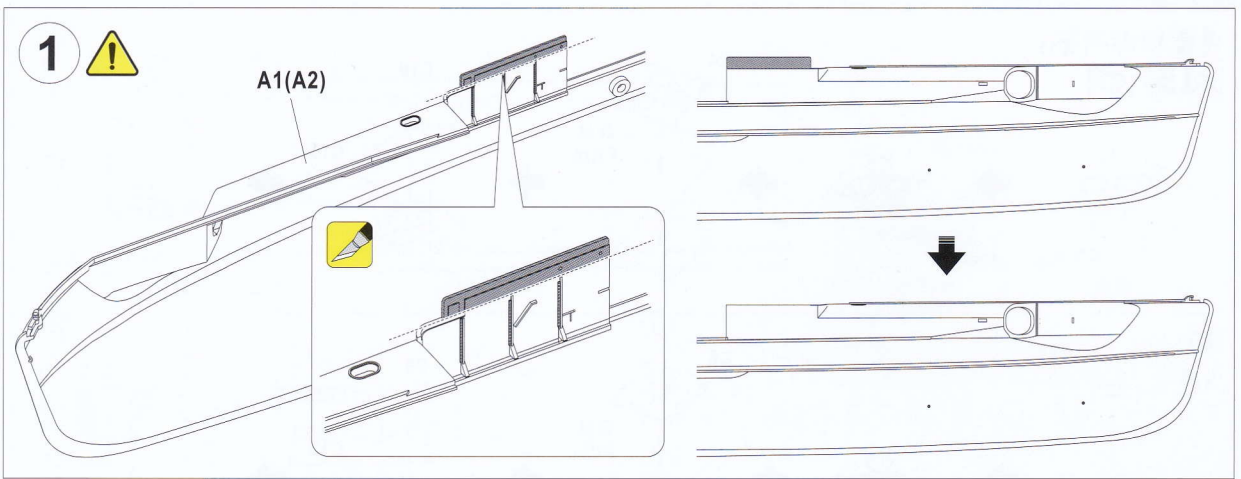

5

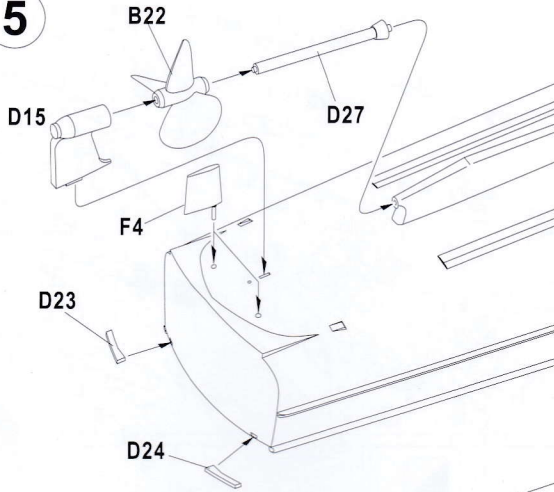

展示底座
Display base

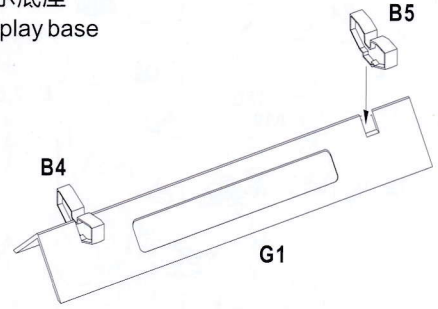

B21(B20)

F29
(F29)

D2

B17(B16)

B15(B23)

6

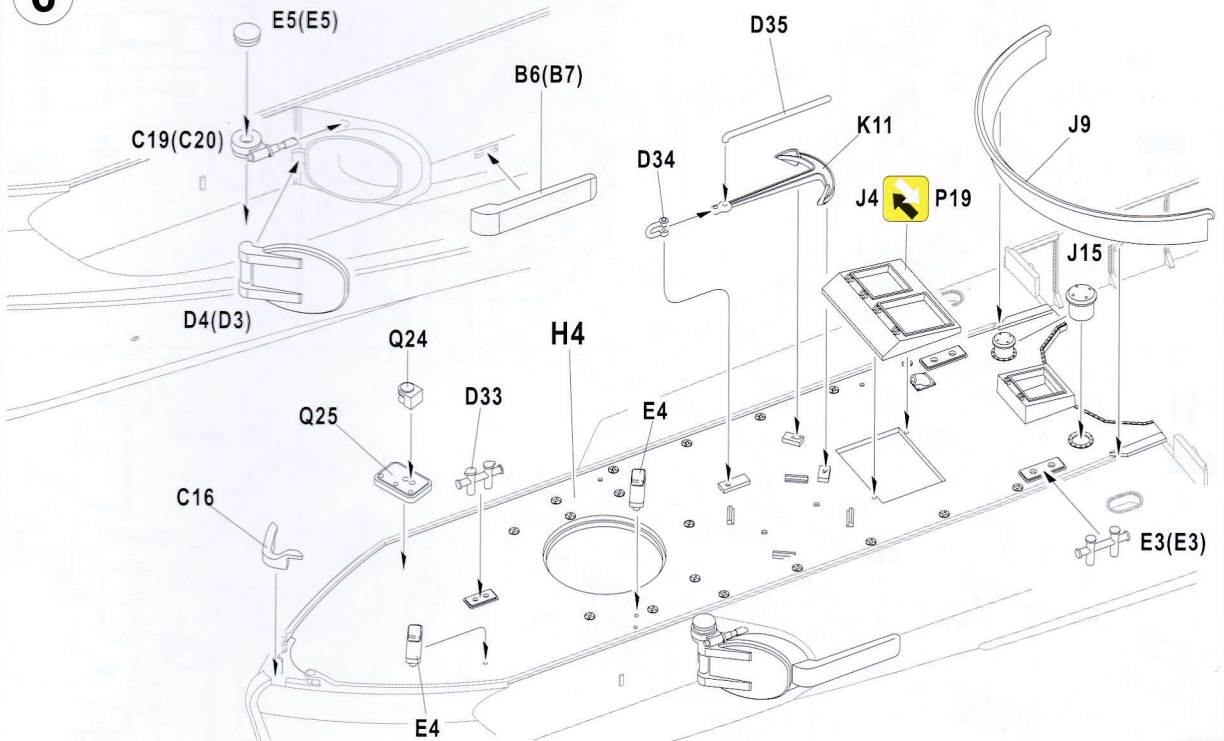

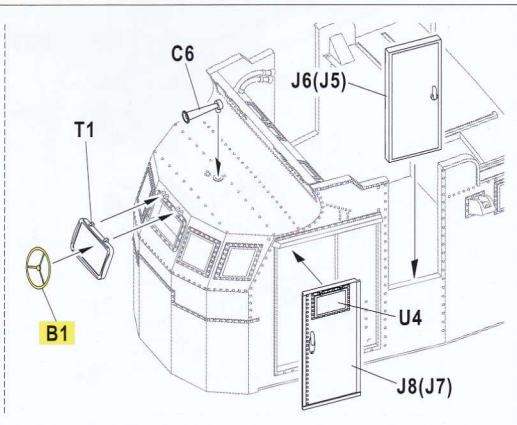
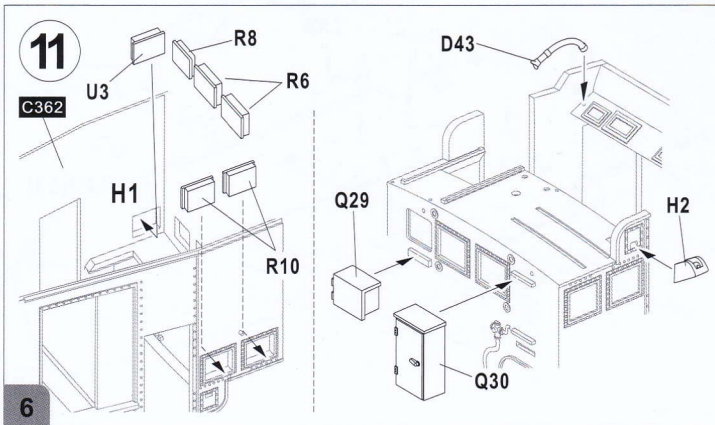
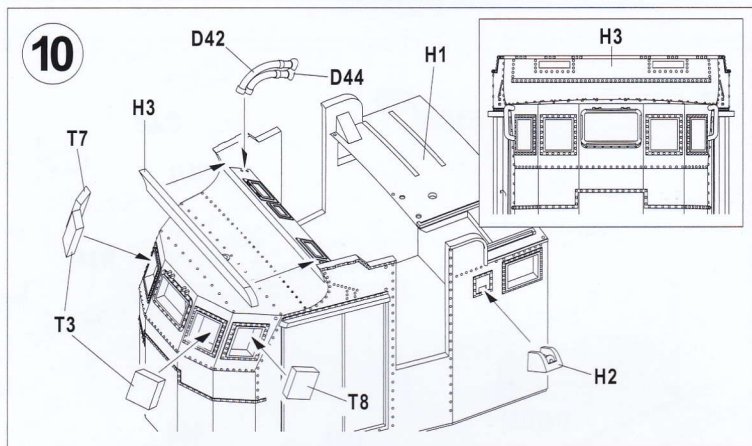
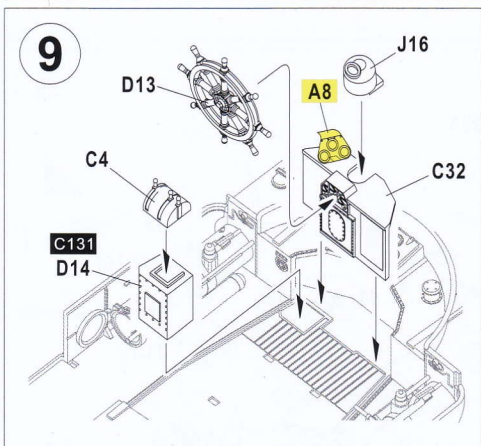
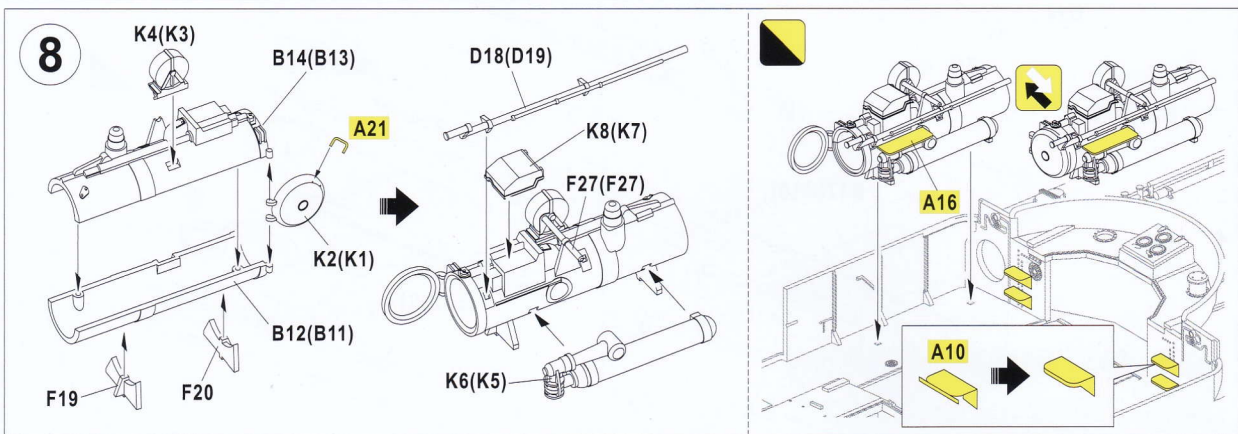
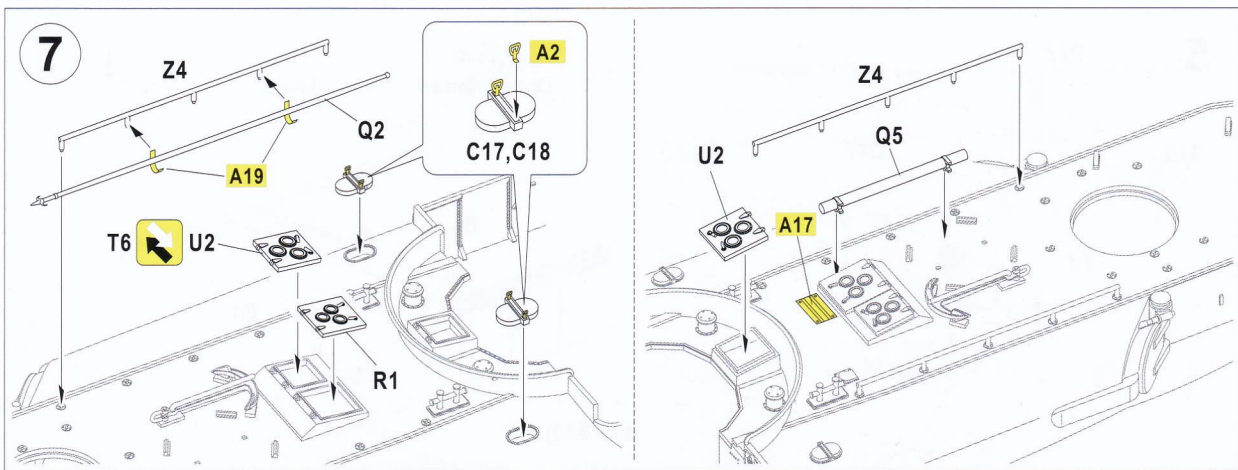

12

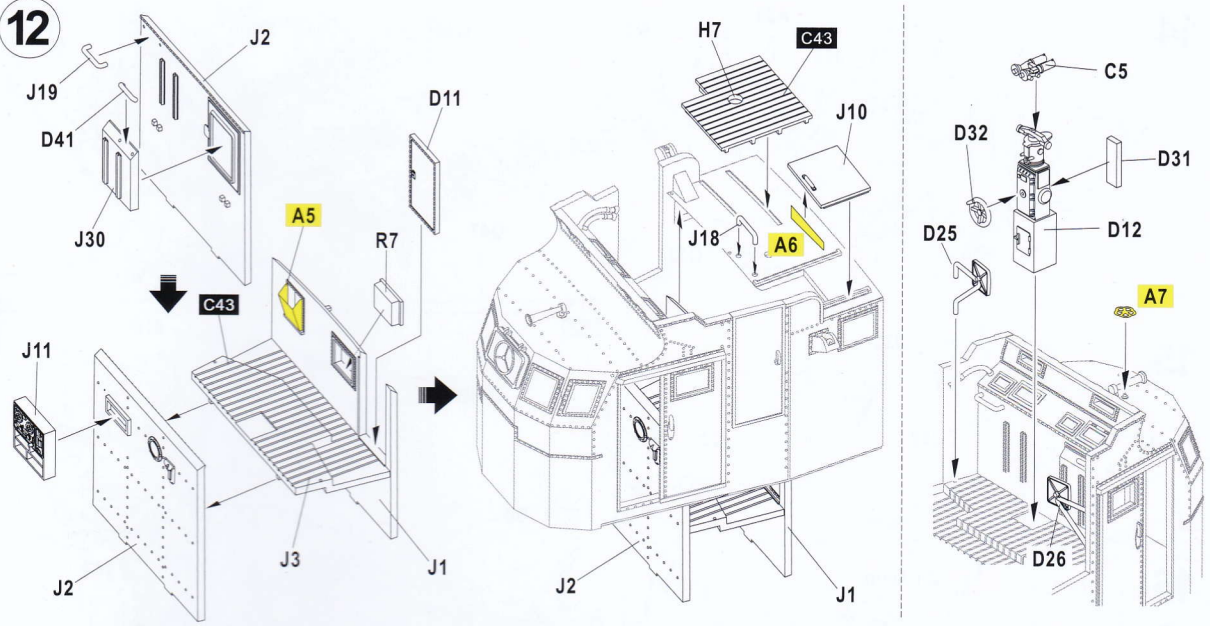

13

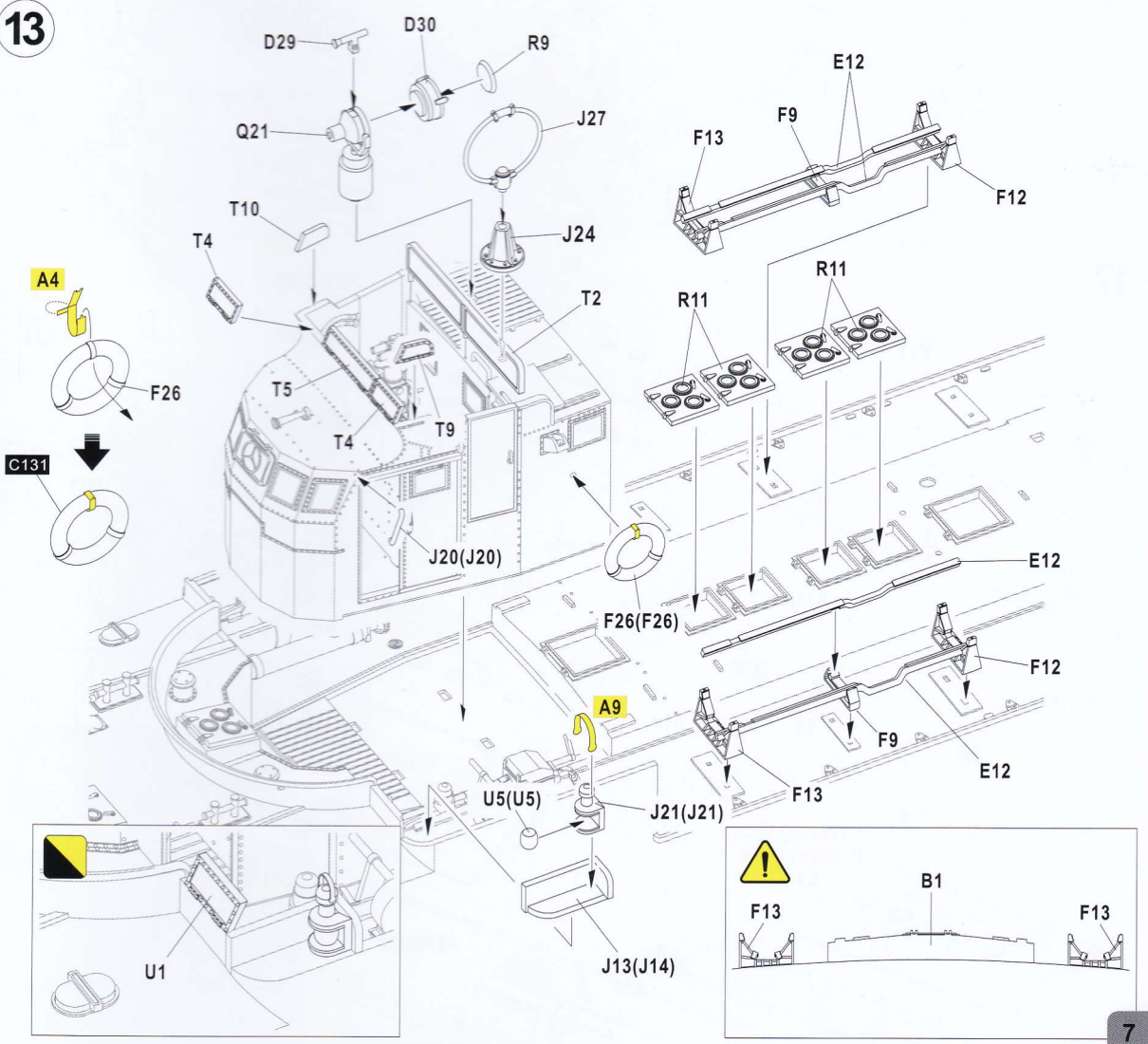

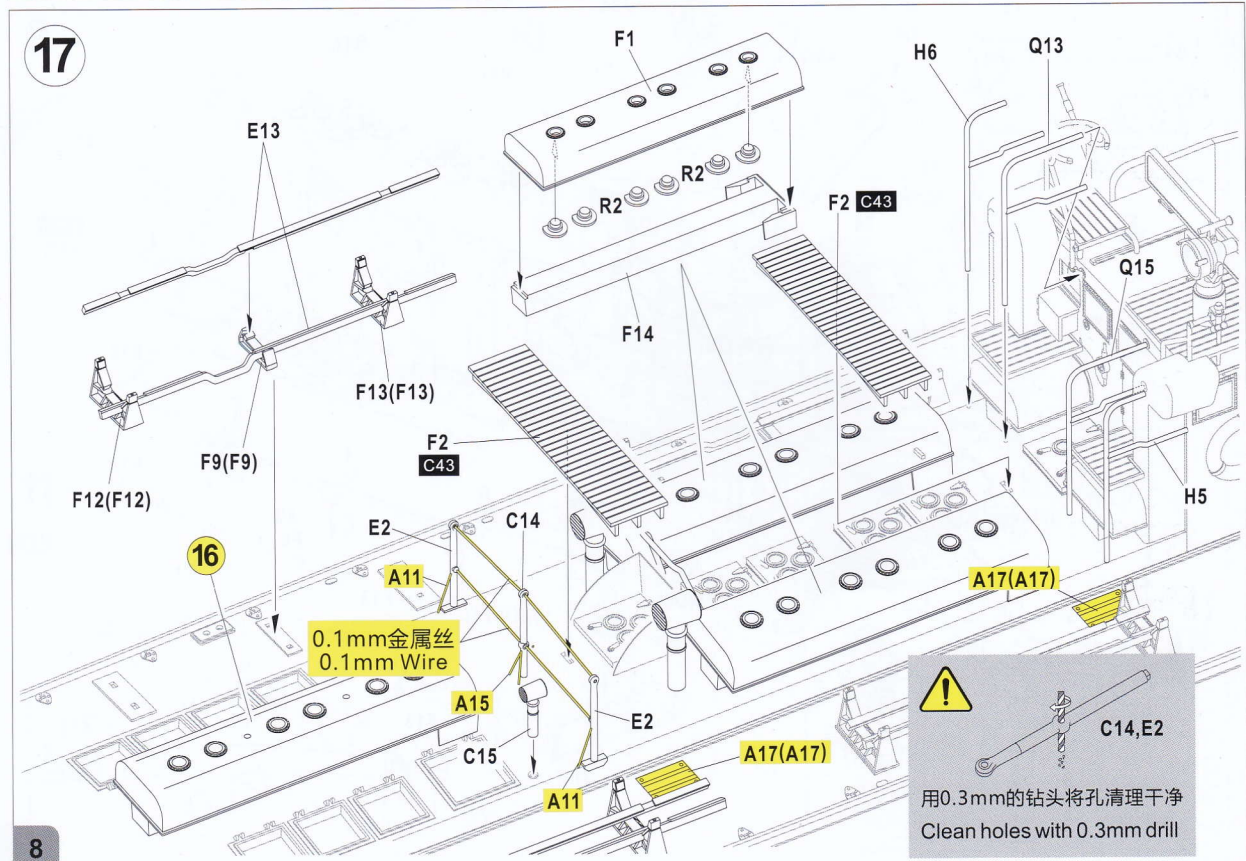
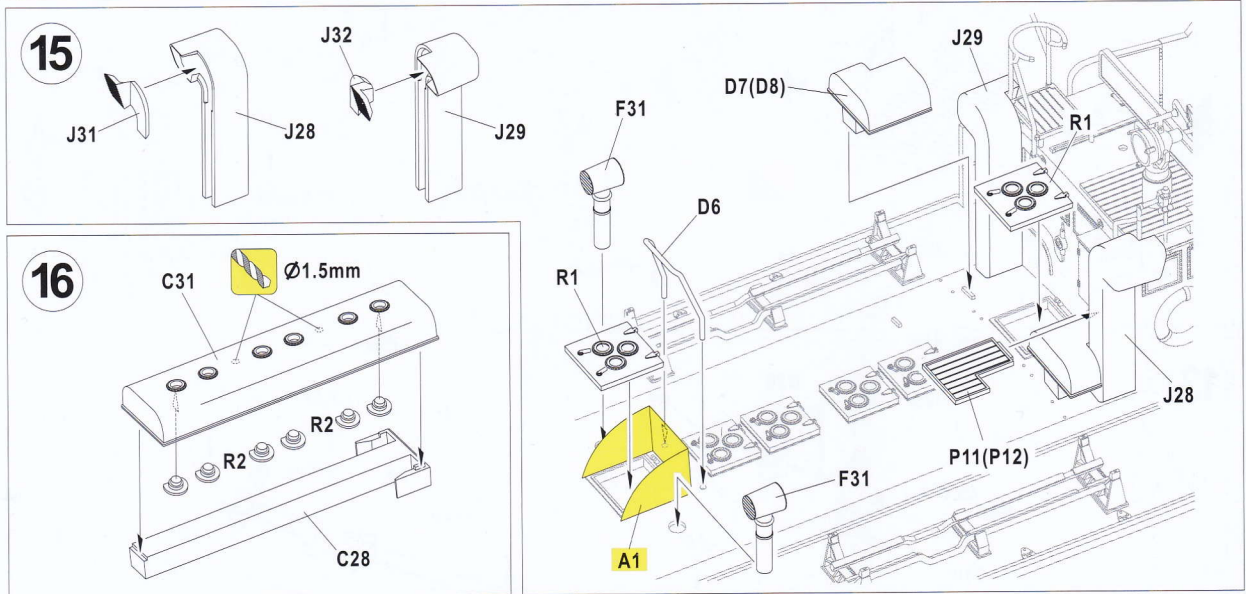
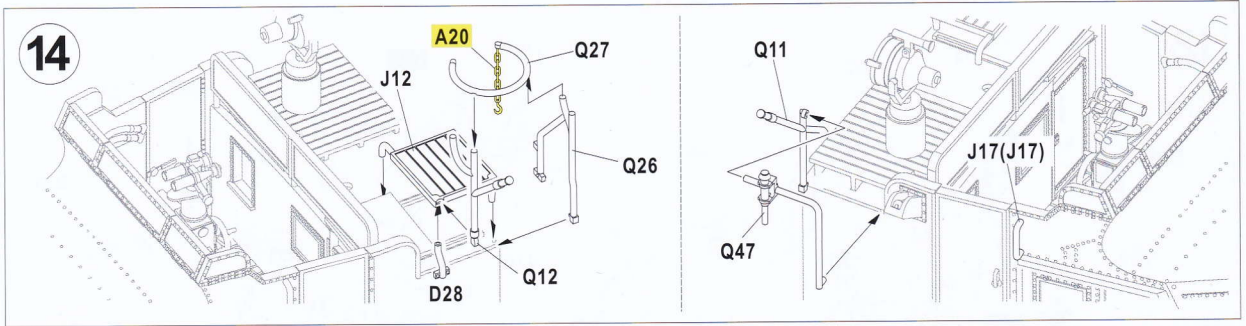

18

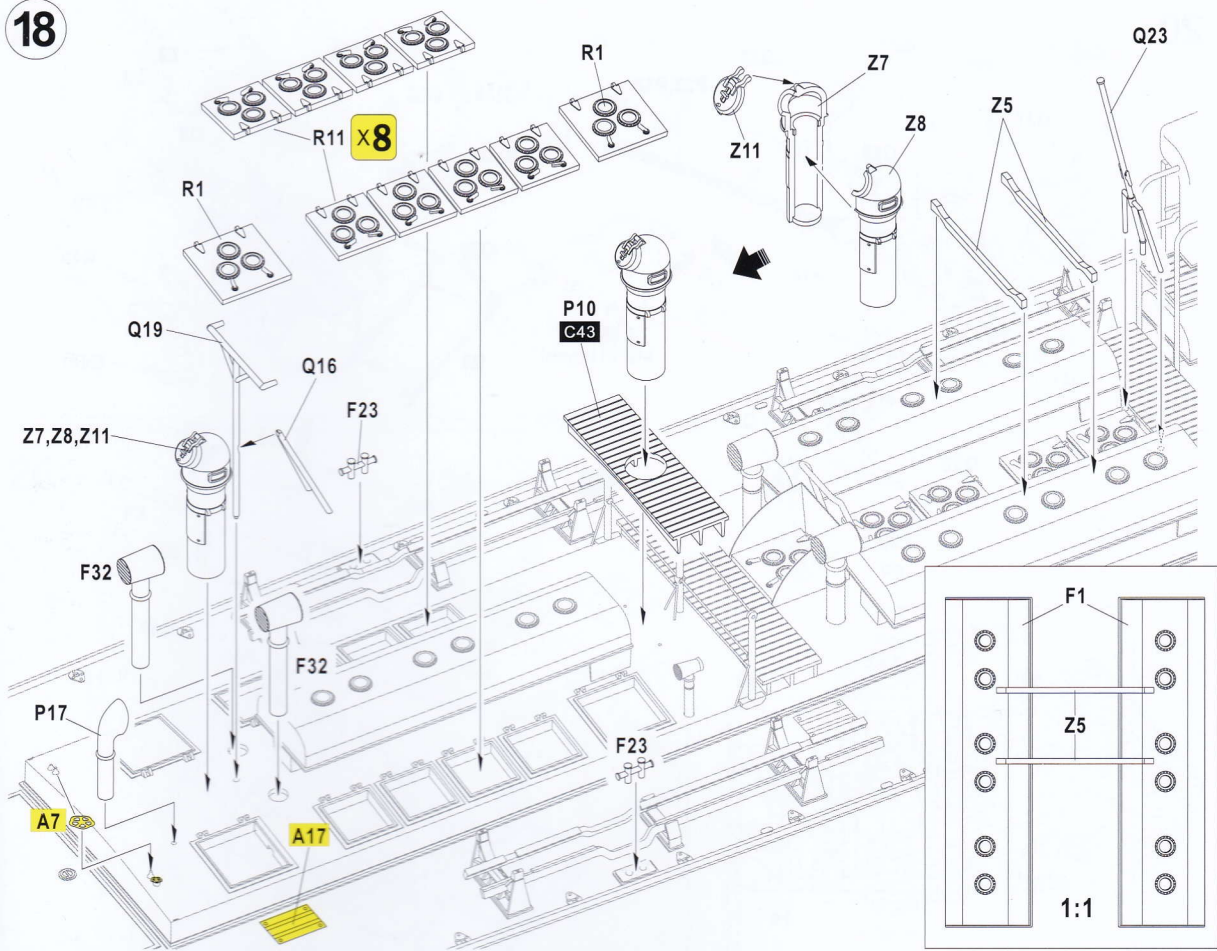

19

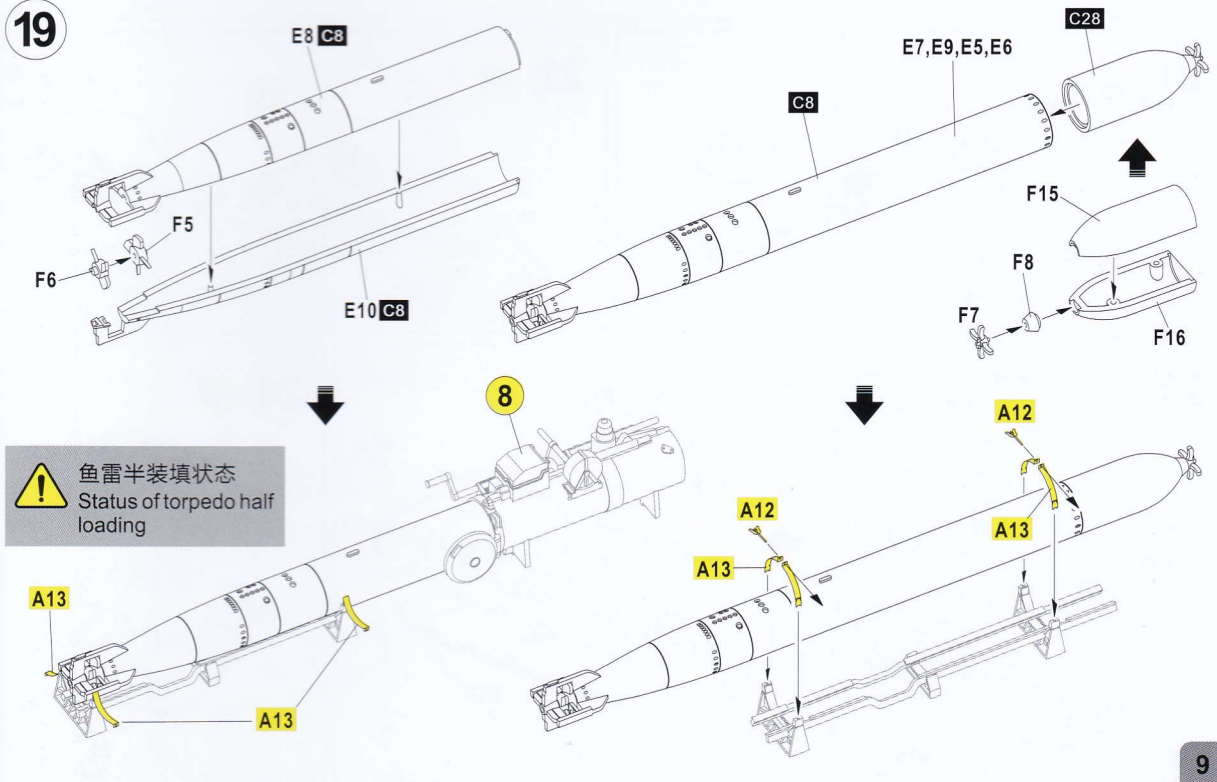

20

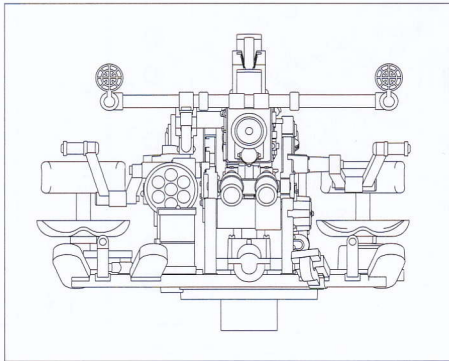
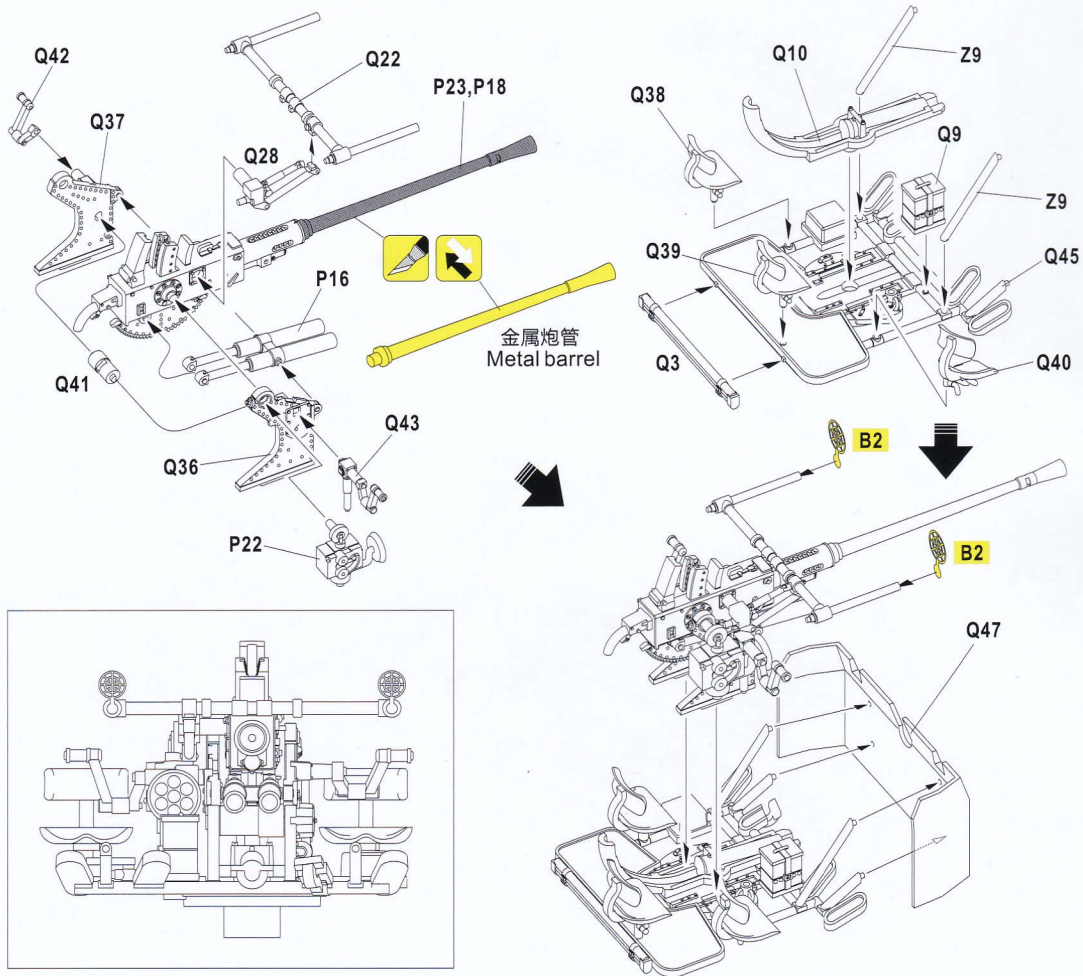

21 x2

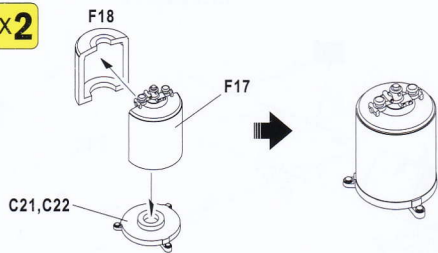

22 x2

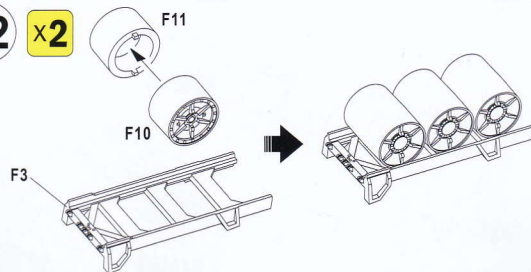

23

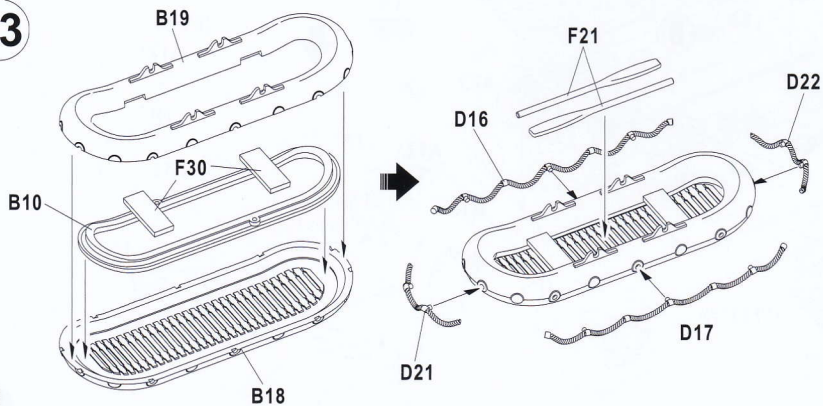

24 x2

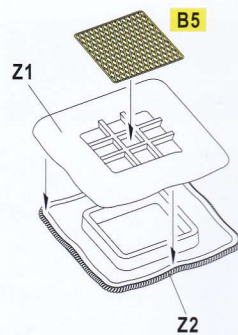

25

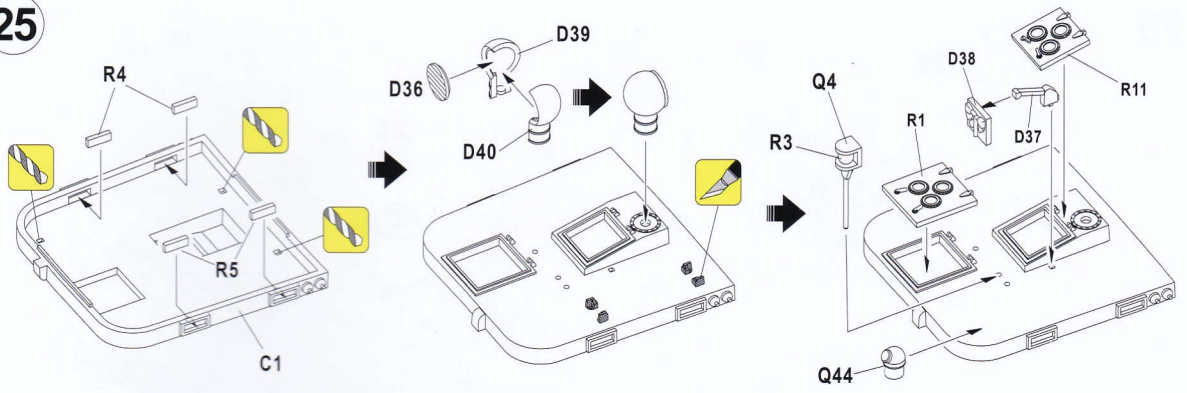

26

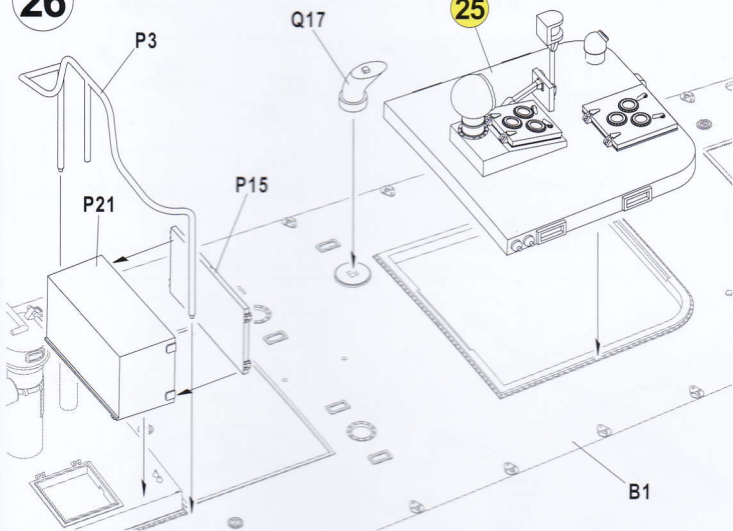

27

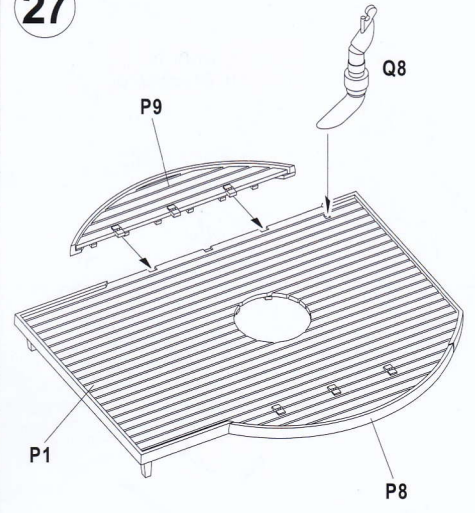

28

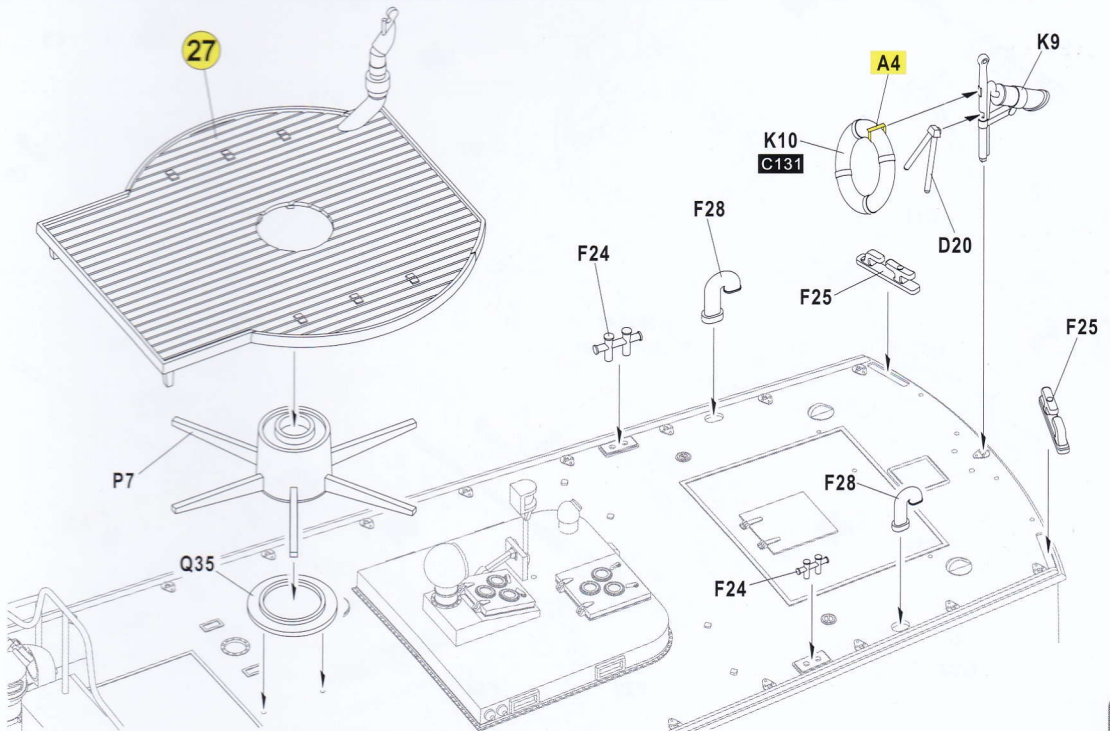

29

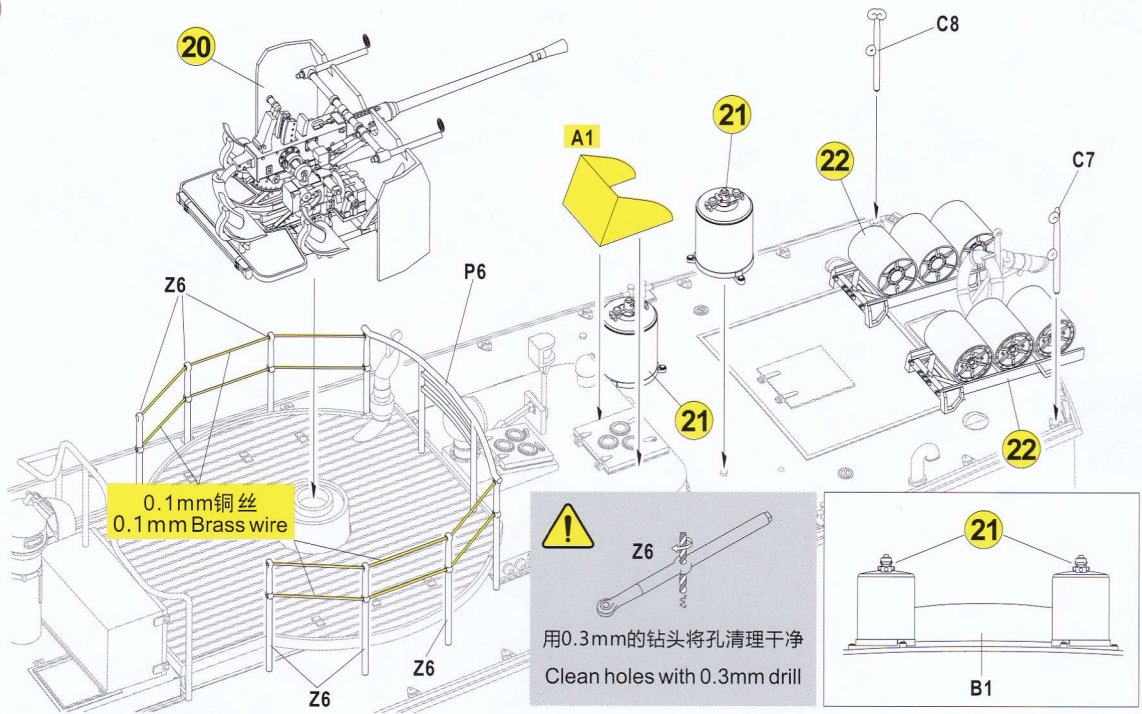

30

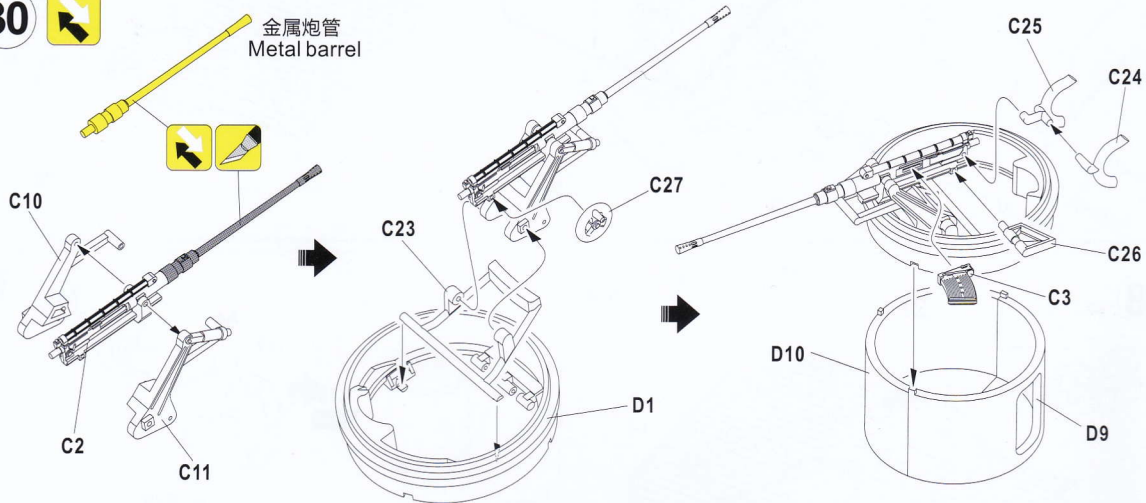

31

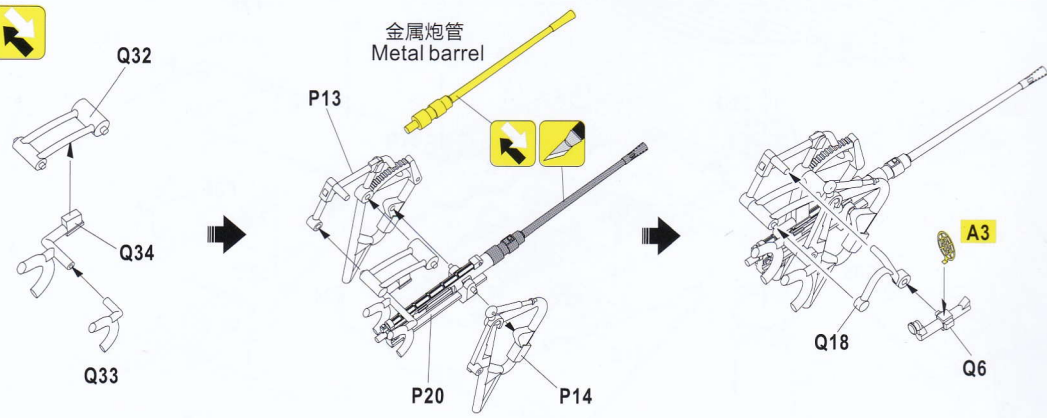

32

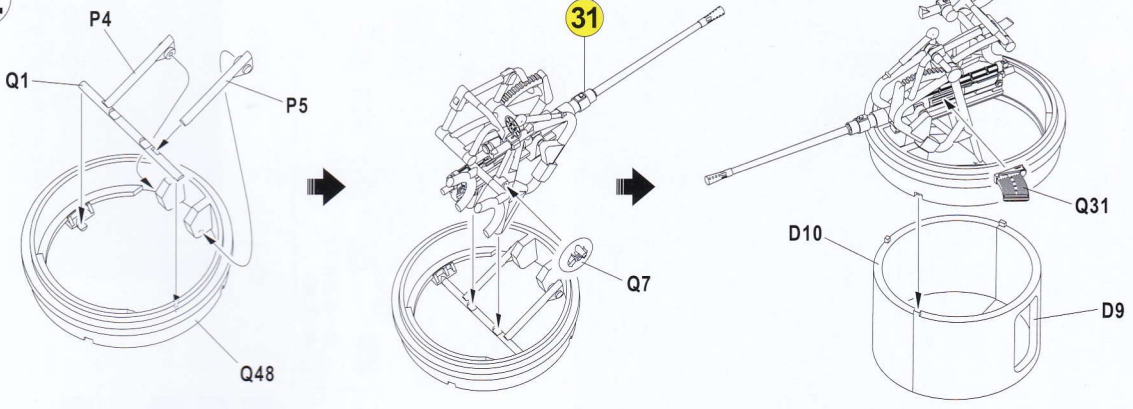

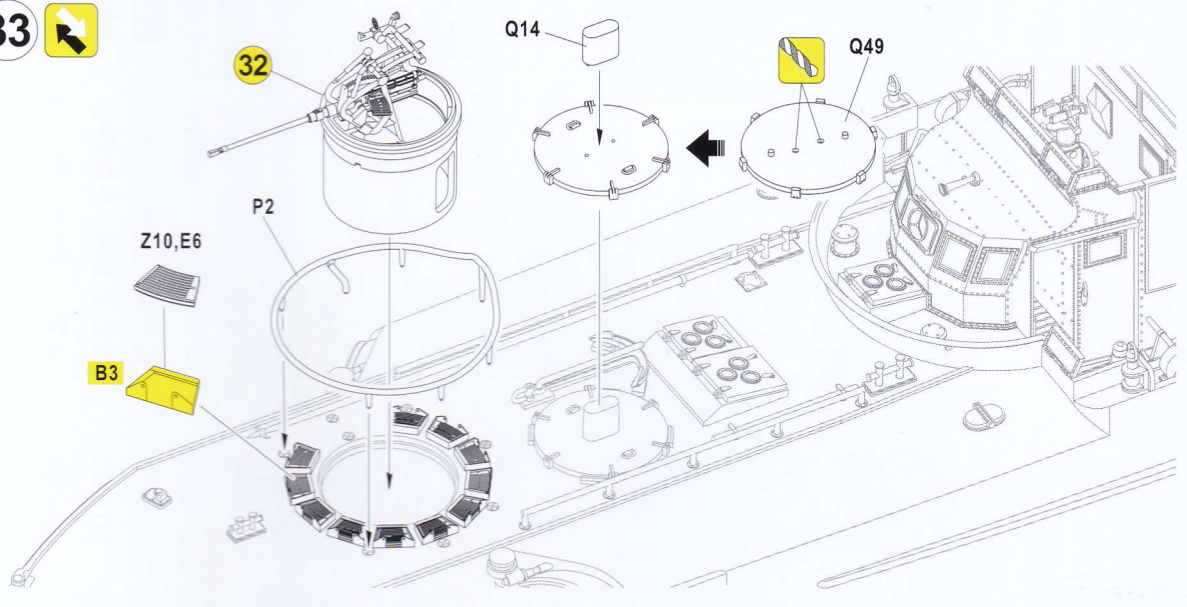

33

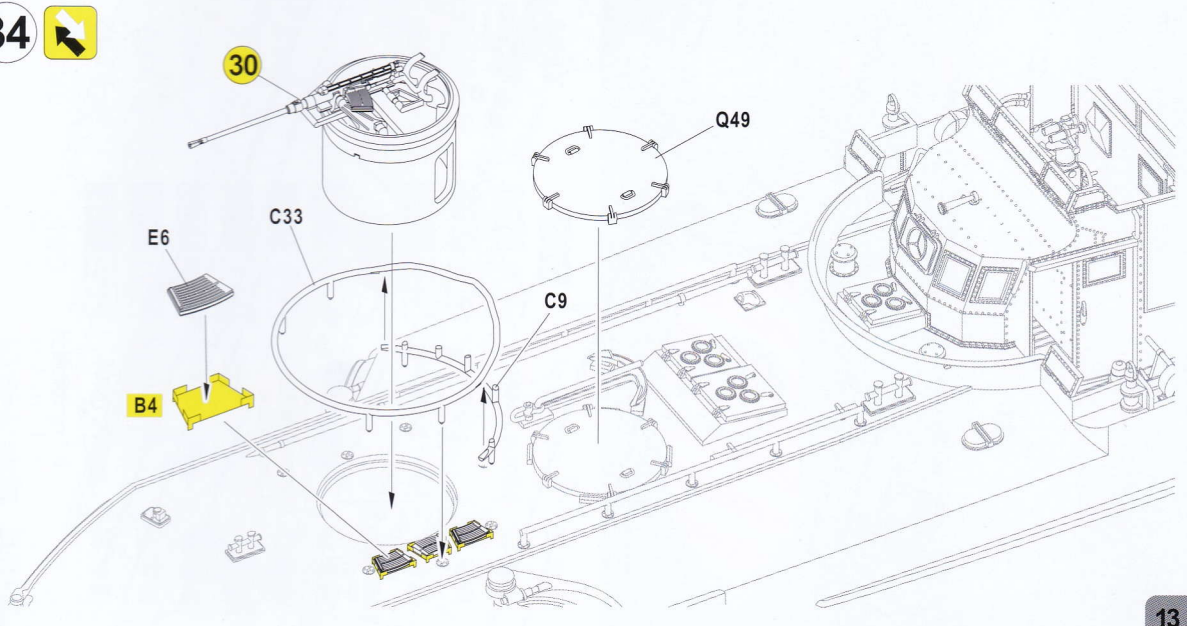

34

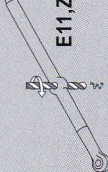

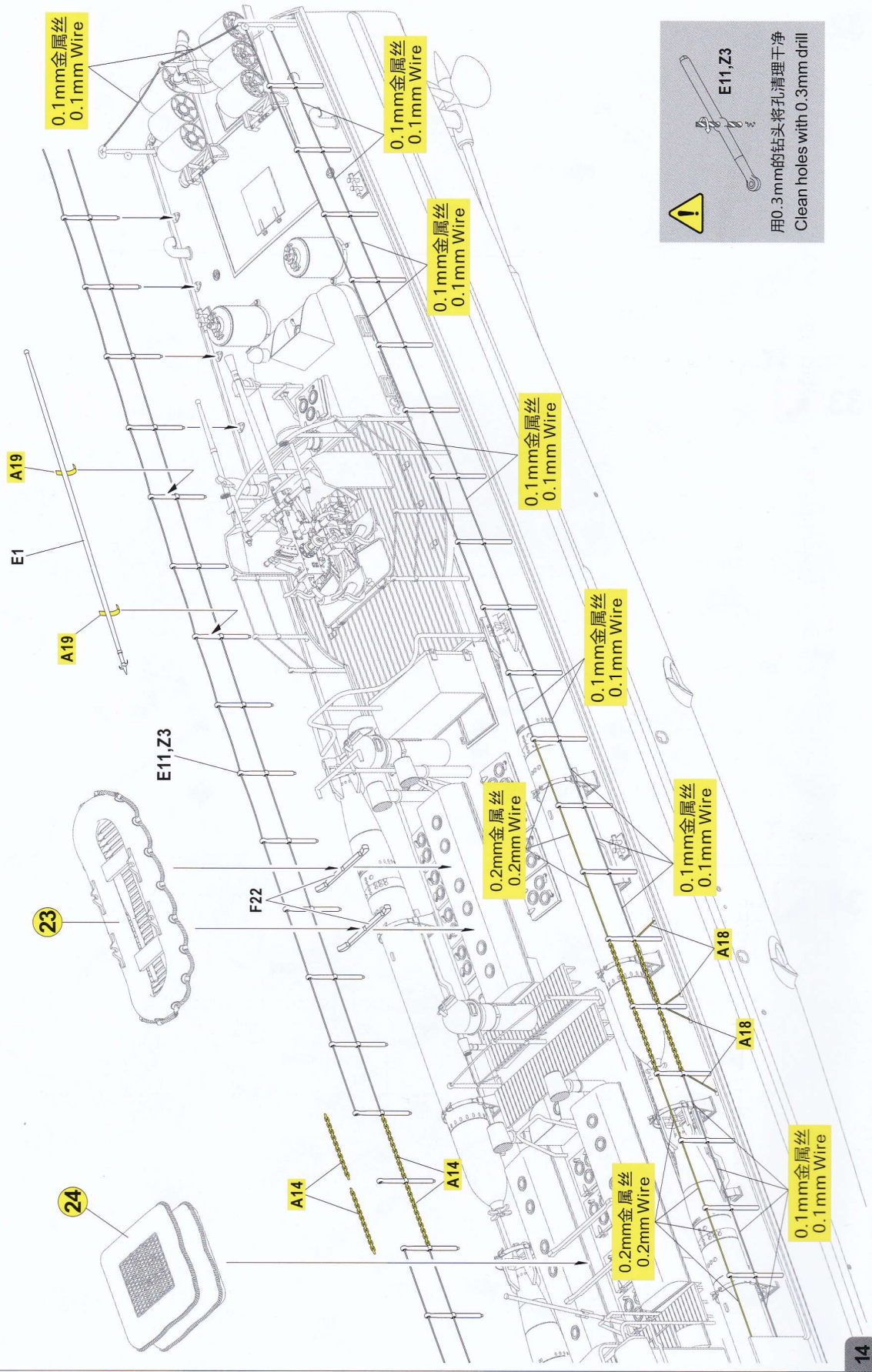

E11,Z3

用0.3mm的钻头将孔清理干净
Clean holes with 0.3mm drill

Print 涂装与标识

Color	GS1	TAMIYA	Vallejo
浅灰色	H-61 C35	XF12	70.993
舰底色	H-17 C29	XF9	70.985
原野灰	H-48 C52	XF65	70.830
红色	H-3 C3	XF7	70.957
绿色	H-6 C6	XF5	70.970
黑铁色	H-18 C28	X10	70.862
RLM04黄色	C113		71.078
铜色	H-9 C9	X33	70.801
银色	H-8 C8	X11	70.883
木棕色	H-37 C43	XF79	70.929
中海灰	C362	XF66	70.870

中蓝	Medium Blue	C366	XF18	70.963
明红色	Dark Vermillion	H-23 C79		70.947
赤褐色	Red Brown	C131		70.982
卡其色	Khaki	H-81 C55	XF49	70.988
金属黑	Glossy Black	H-28 C78	X18	70.861
消光黑	Flat Black	H-12 C33	XF1	70.950

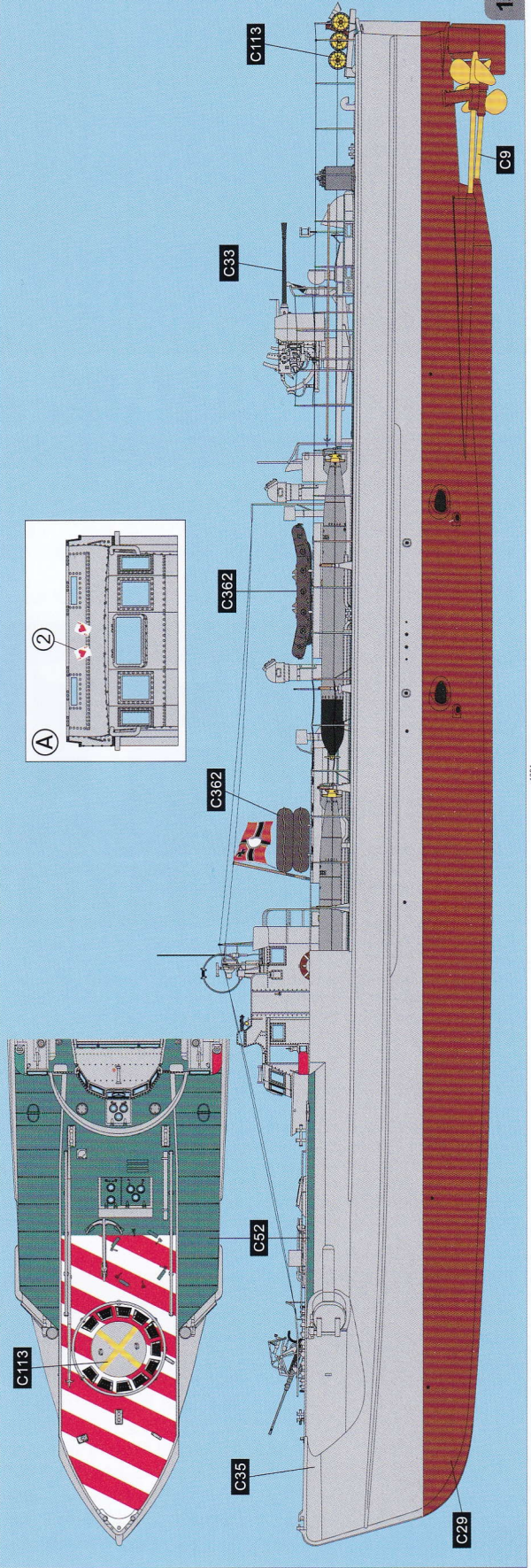
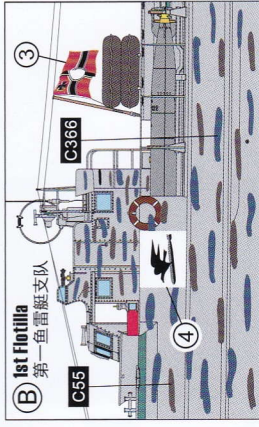
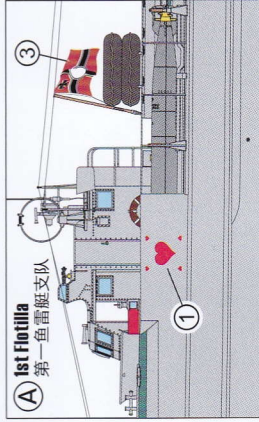

FORE
HOBBY