



SCALE 1/35 AF 35124



IDF SHOT KAL

CENTURION MK 5/1

***The data is offered by Mr. Robert Manasherob*

During the 1967 Six-Day War, IDF had been suffered by British-made Centurion tank's short operational range. After this conflict, the IDF stated to upgrade with the American Continental AVDS-1790 diesel engine to replace the Rolls Royce Meteor petrol engine. The IDF logistic system largely benefited from this new engine because it can be operated with a variety of fuels. Furthermore, M48 and M60 tanks all adapted the same serial of engines, which just introduced to the IDF. To accommodate this new air-cooled engine, the compartment has been largely modified -height was increased to provide better cooling surface area; and length was also increased to accommodate new transmission system. This re-engined Centurion was redesignated as "Shot Kal".

On the eve of Yom Kippur war, the IDF had more than 1000 Shot Kal tanks in inventory, almost took up to 50% that of in the Armoured units. With thicker armour plates, it is considered to give the personnel better protection, comparing to M48 and M60. Therefore Shot Kal tanks were mostly deployed in northern hilly terrain area, close to Syria border. On the contrary, M48s and M60s, which are equipped with torsion bar suspension system and rubber block tracks were mostly deployed in southern open terrain area.

In the 1973 Yom Kippur war, outnumbered by almost 9 times, the Sh' ot Kal tanks fought fiercely with Syrians, whose target was to retake the Golan Heights. Despite almost most of the Sh' ot Kal tanks and many lives were lost in the conflict, yet time was gained so that reinforcement could be assembled, and IDF managed to launch its counteroffensive. By 15th October had pushed the Syrians back well east of the 1967 cease-fire line.

1967年の六日間戦争の際、イギリス製センチュリオン戦車の航続距離の短さに悩まされたIDF (イスラエル国防軍)は、この戦争の後、センチュリオン戦車のロールスロイス・ミーティアガソリンエンジンを、コンチネンタル社製AVDS-1790ディーゼルエンジンに交換する作業に着手する。AVDS-1790エンジンは数種類の燃料が使用可能だったことに加え、IDFが導入していたM48、M60といった戦車も同系のエンジンを搭載していたので、整備・補給業務の効率面で、大きな恩恵を受けることとなった。この新しい空冷エンジンの搭載により、エンジンルームは大きく改造が施されることになり、冷却効果向上のために高さが増加し、トランスミッションの変更に伴って長さが伸ばされていた。こうしてエンジンを載せ変えたセンチュリオンは、Shot Kal (ショット カル)の名称が与えられた。

第四次中東戦争(ヨム キプール戦争)の直前、IDFは1000輛を超えるショット カル戦車を保有しており、これは機甲部隊のほぼ半数を占めるものであった。M48戦車やM60戦車に比べ、乗員防御力向上のためにより厚い装甲を施されたショット カル戦車は、シリア国境に近い、北部の地形の険しい地域に配備され、それに対しトーションバーサスペンションや、ラバーブロック装着キャタピラを装備したM48戦車、M60戦車は南部の開けた地域に配備された。

1973年の第四次中東戦争でショット カル戦車は、数においてほぼ9倍に及ぶゴラン高原奪還をめざすシリア軍を相手に激しい戦闘を繰り広げた。この戦闘で、ほとんどのショットカル戦車と多くの兵士の命が失われたが増援部隊の到着まで持ちこたえ、IDFは反撃を開始、10月15日までにシリア軍を1967年の休戦ラインの東まで押し返したのだった。

1

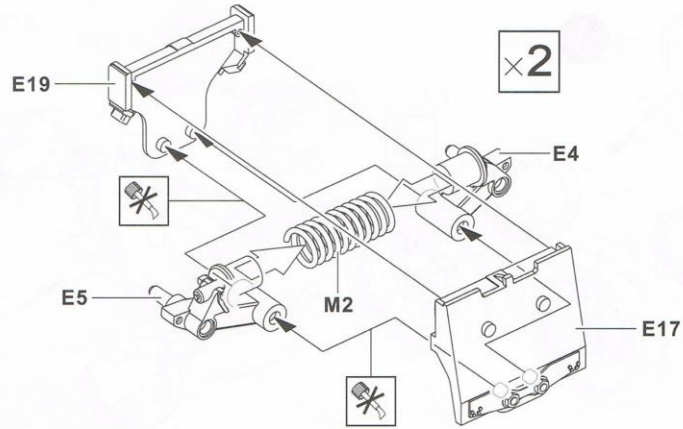

A

2

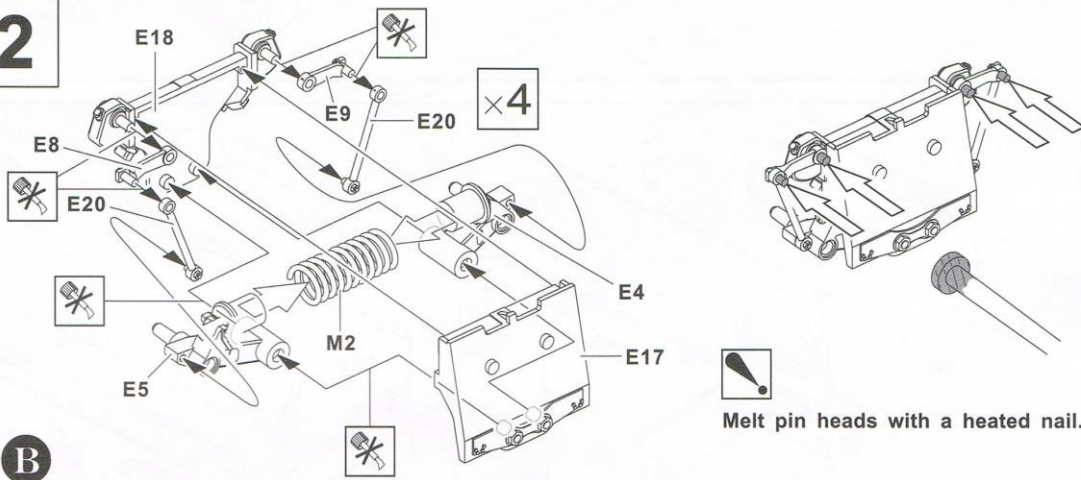

B

3

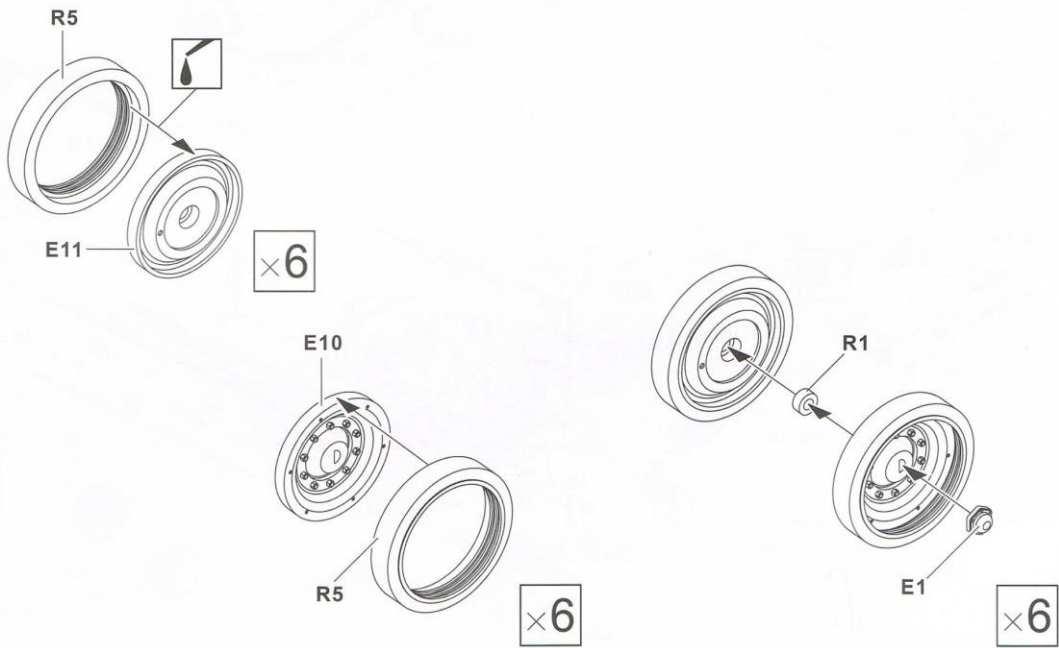

4

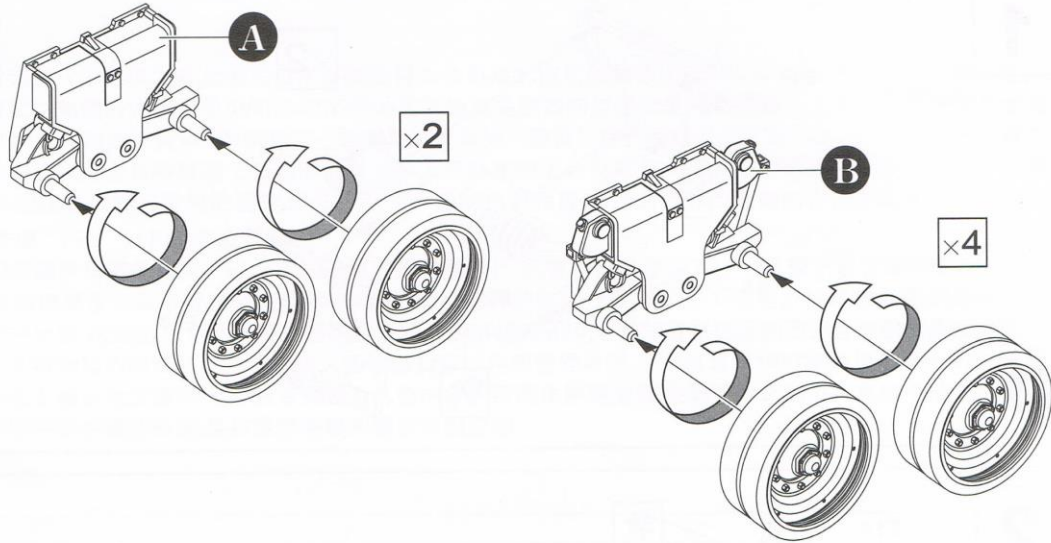

5

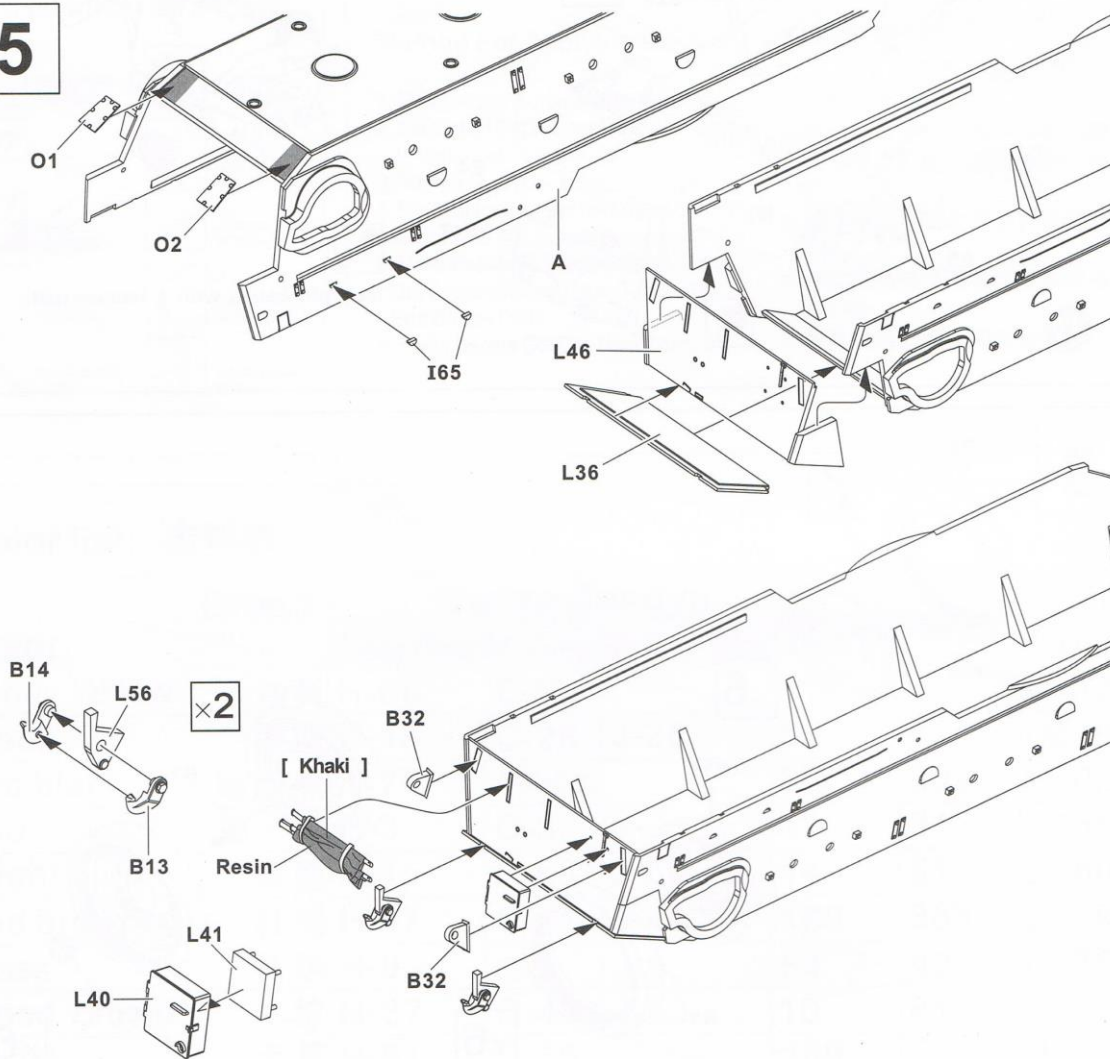

6

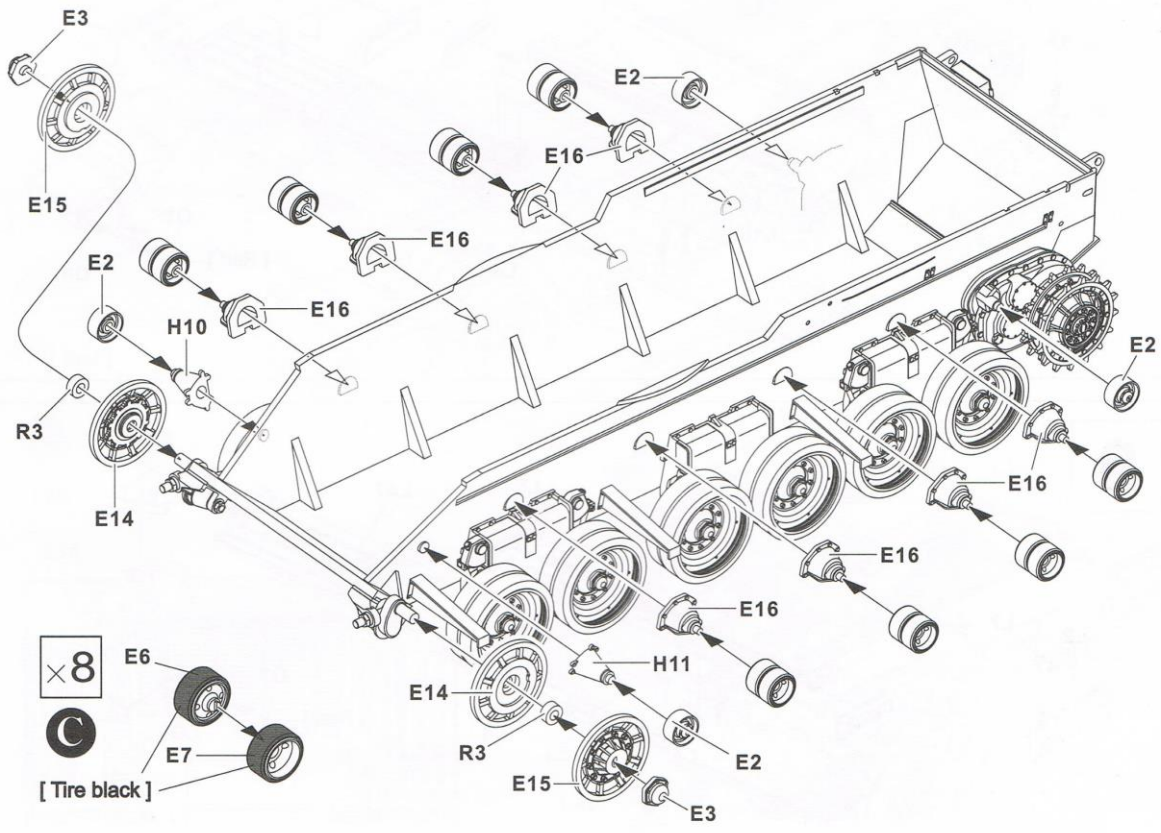
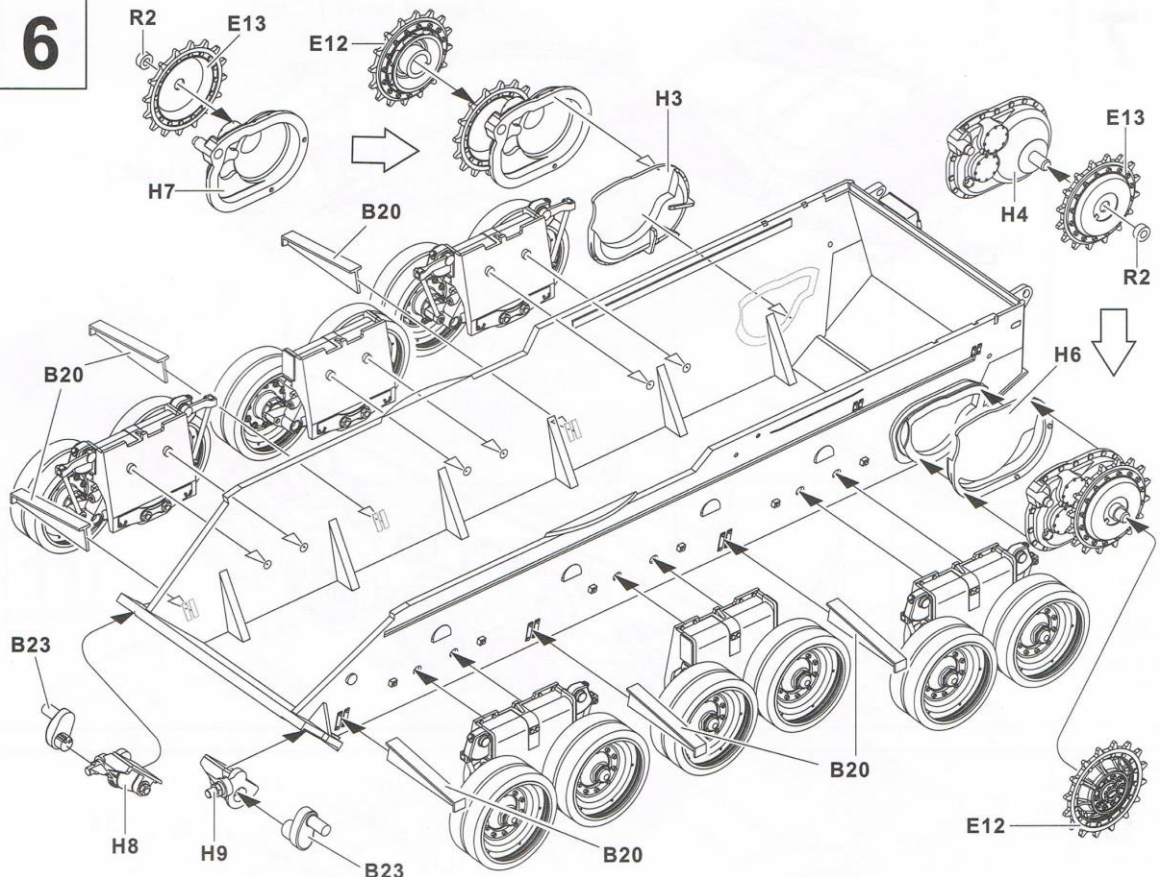

7

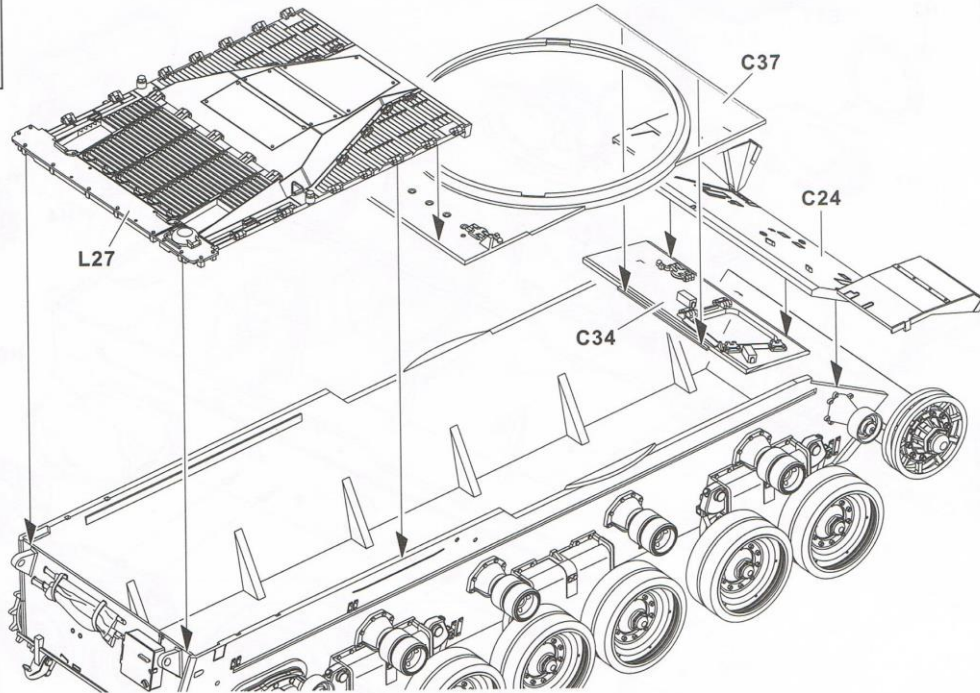

8

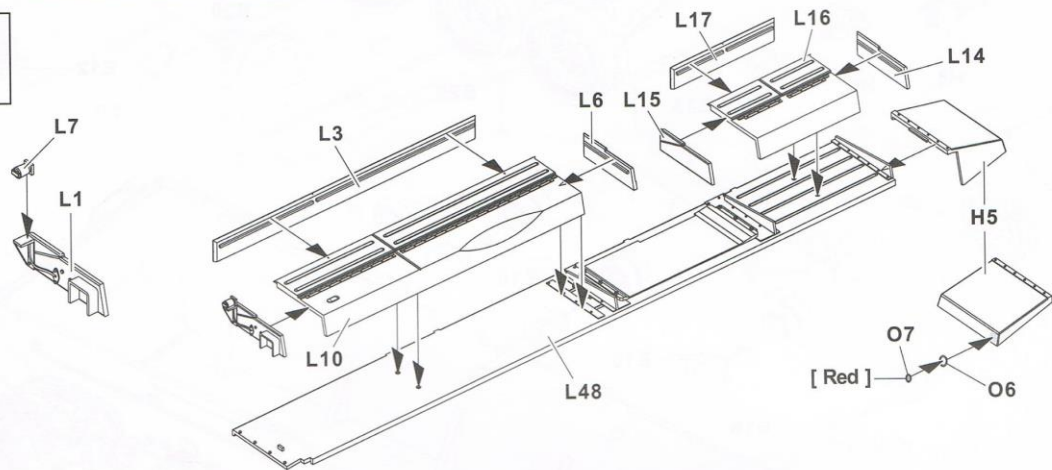

9

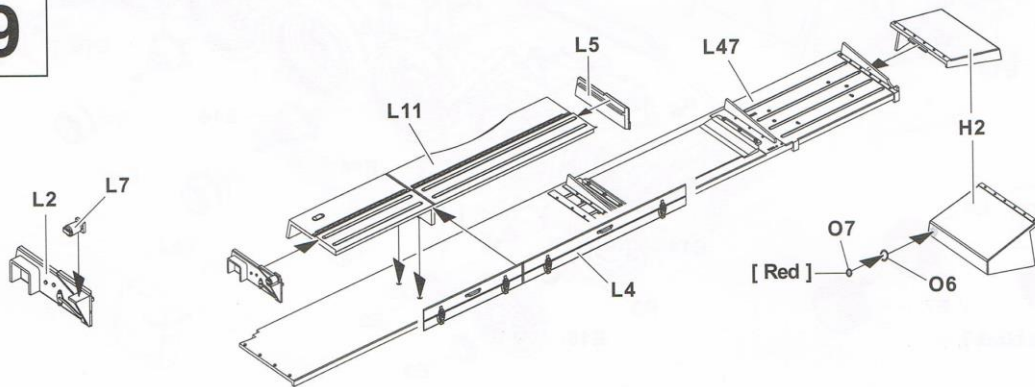

10

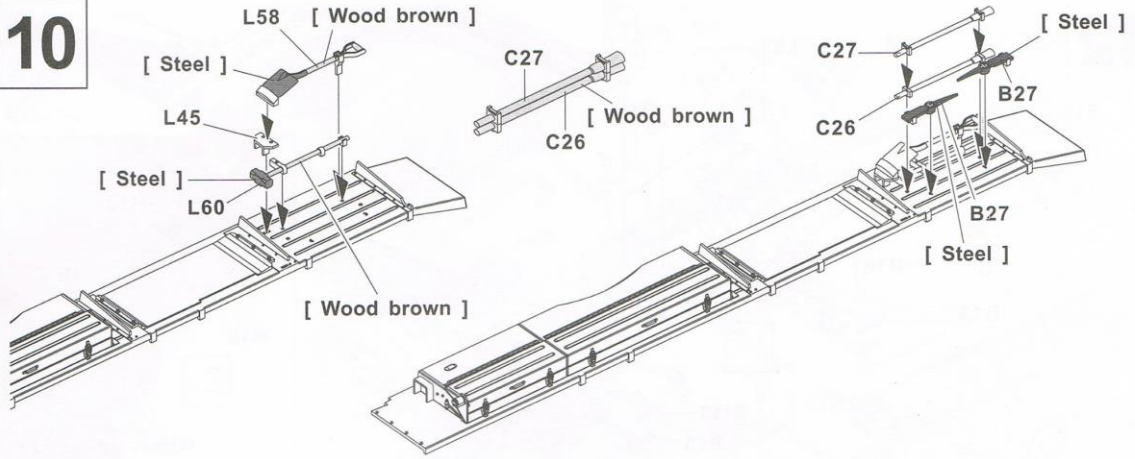

11

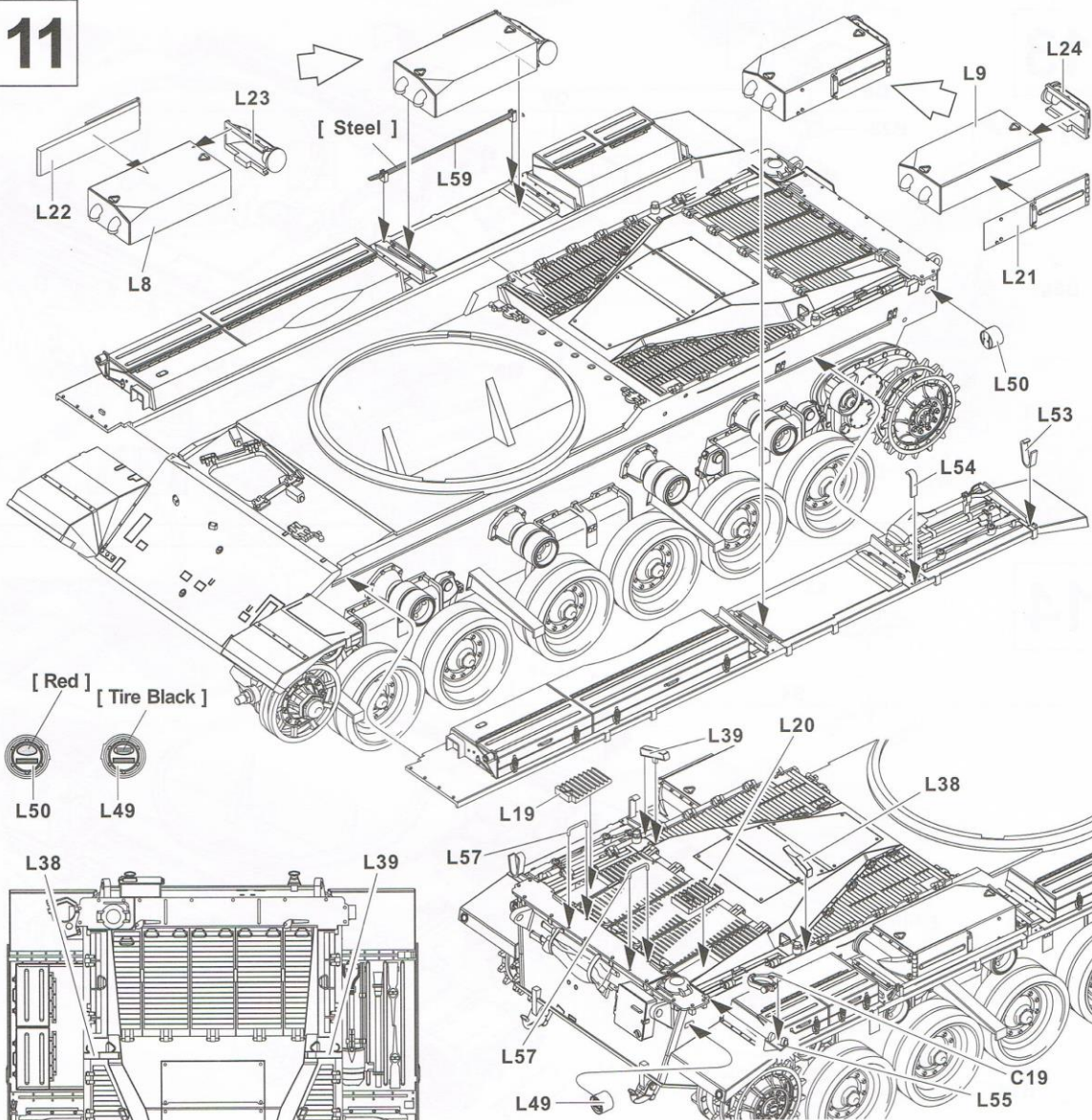

12

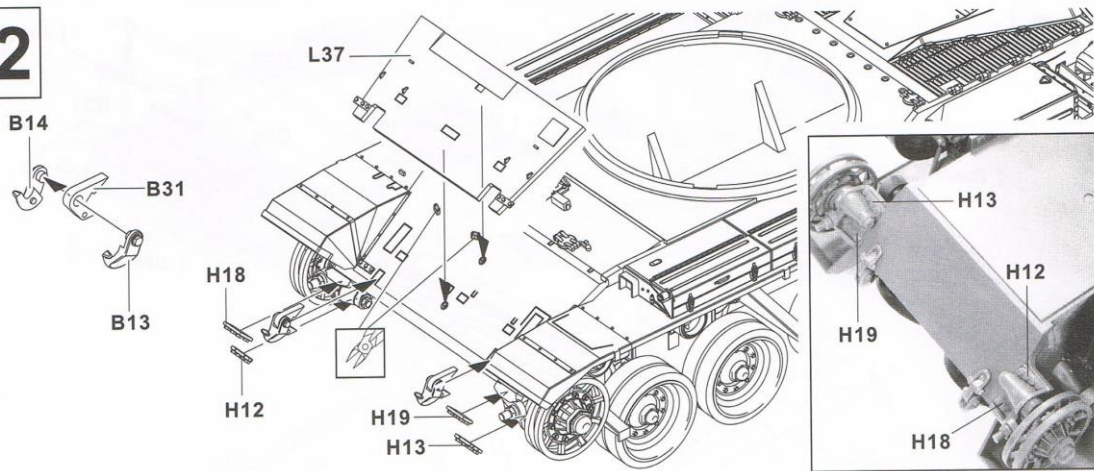

13

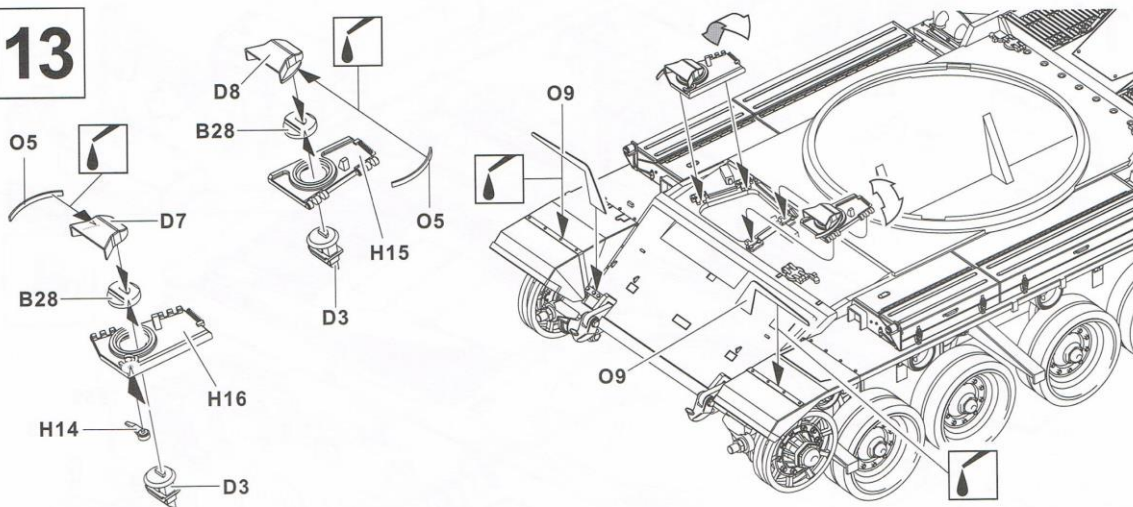

14

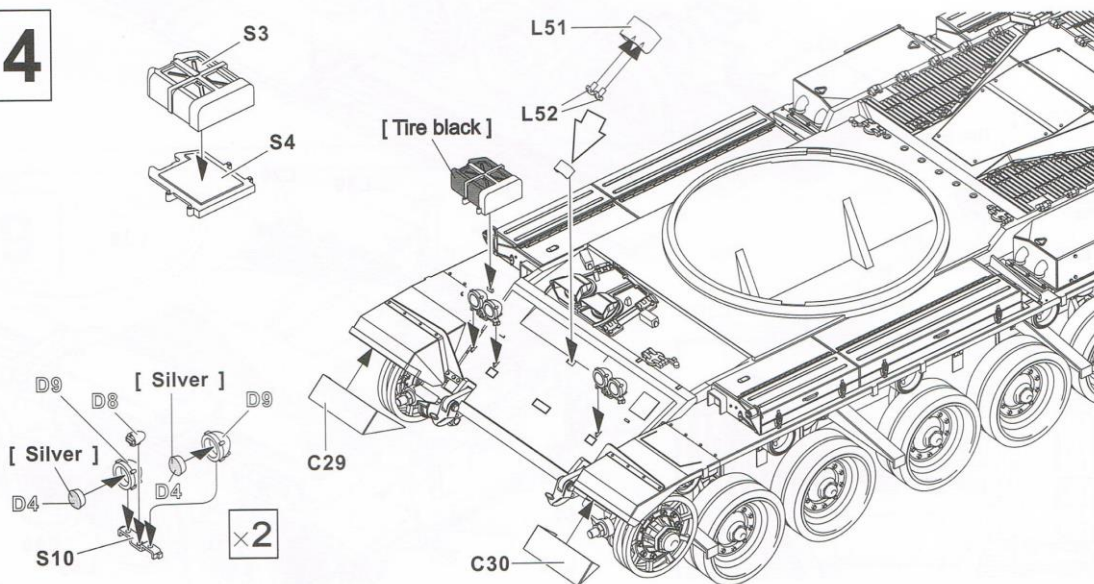

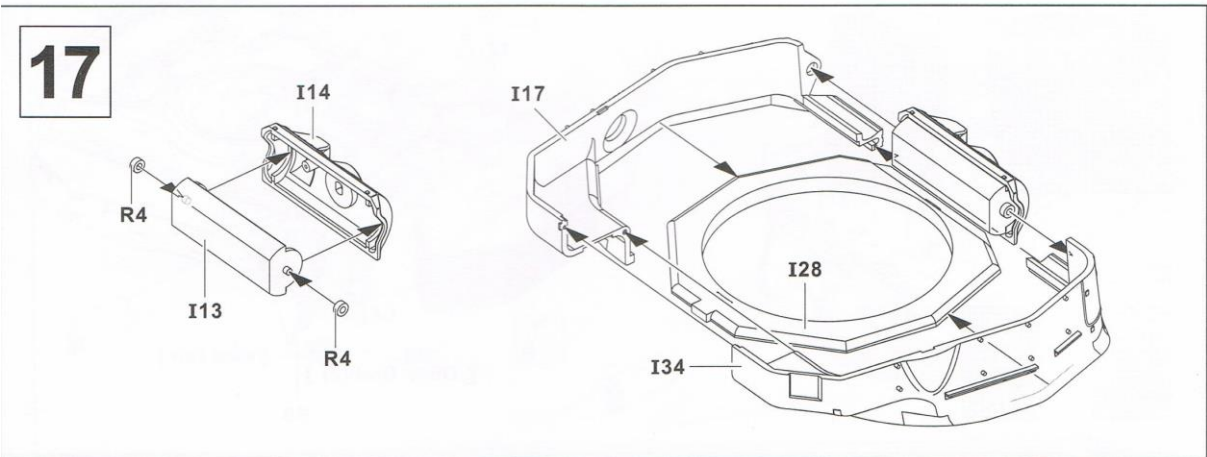
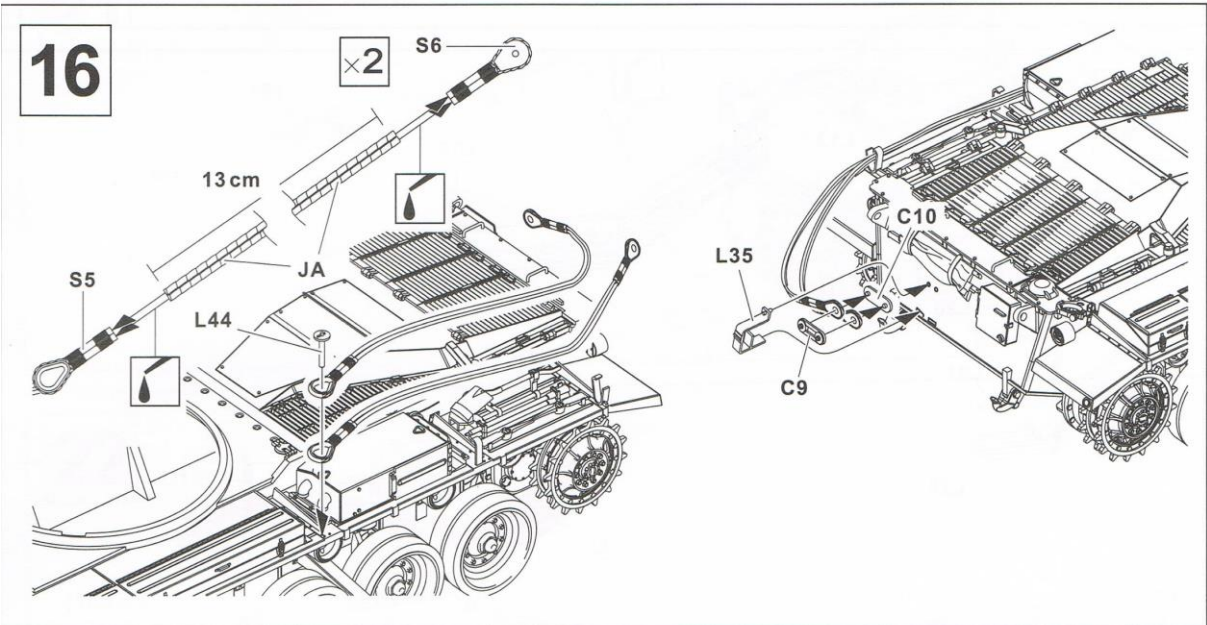
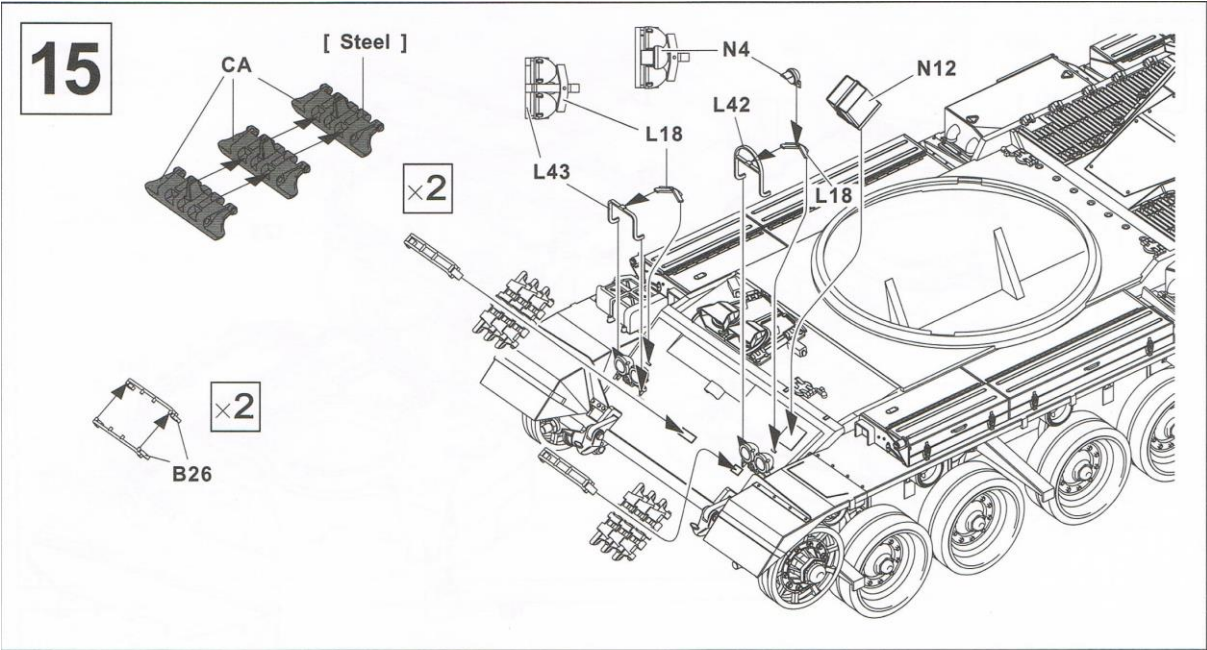

18

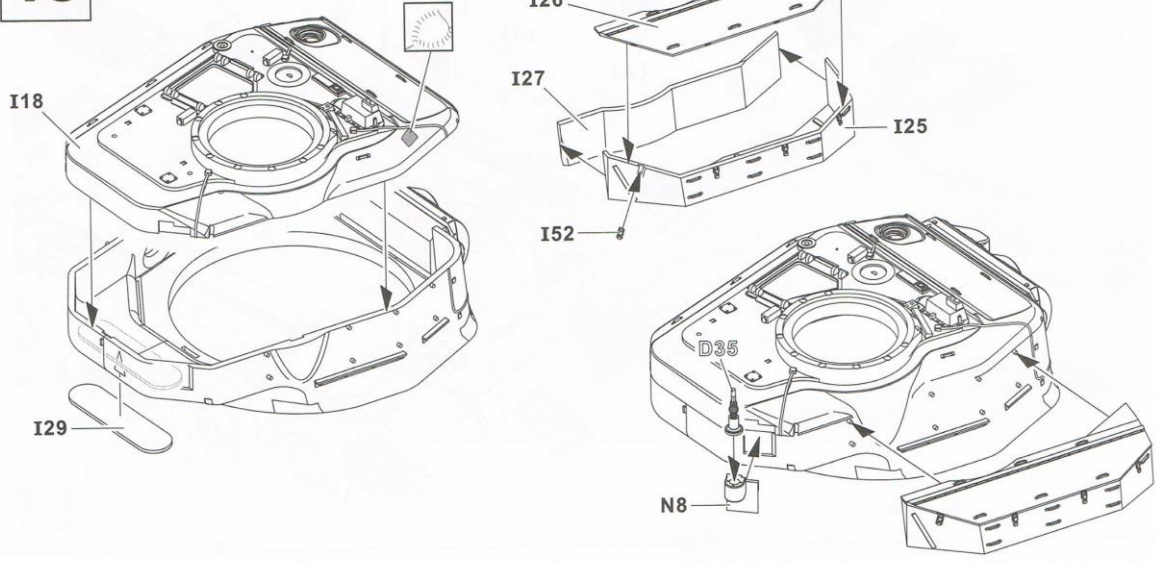

19

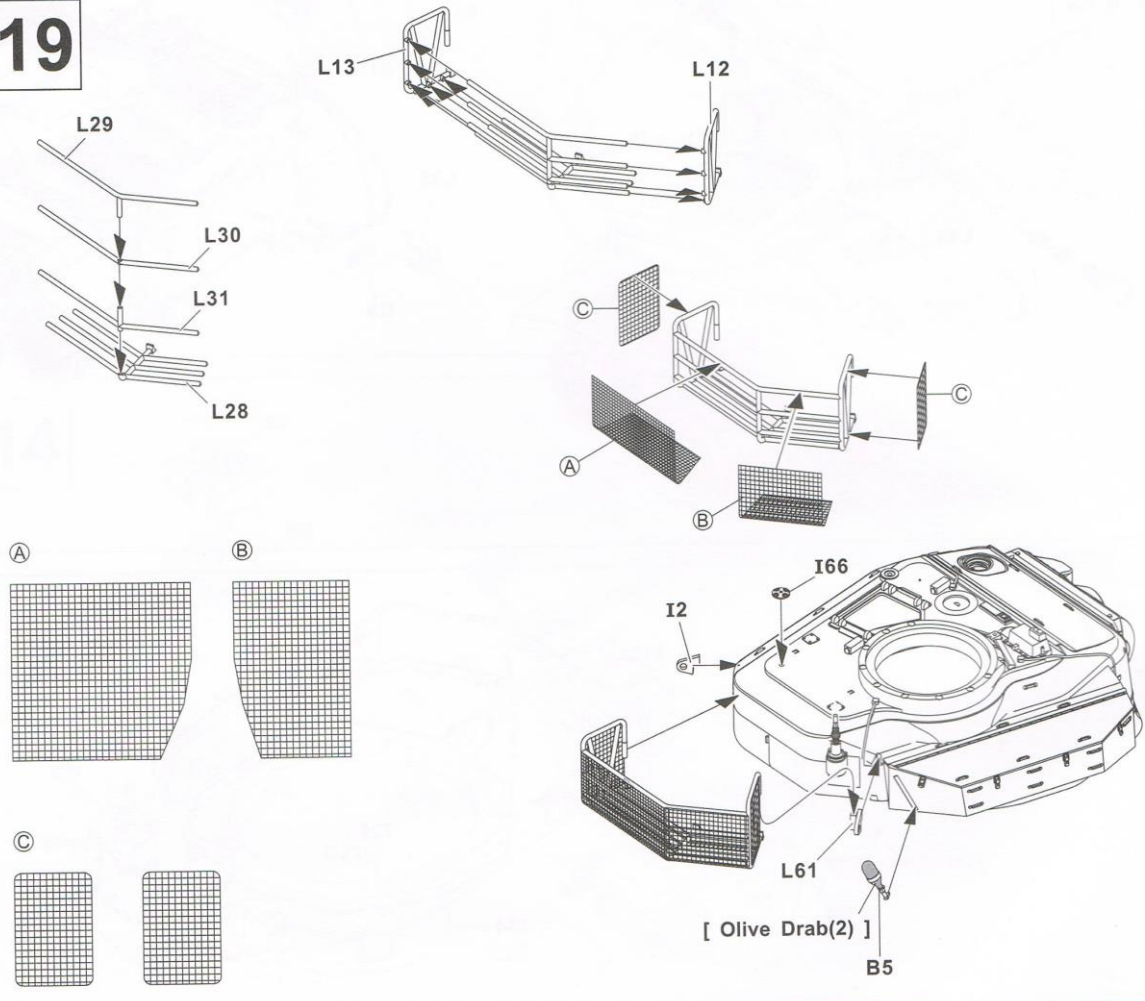

20

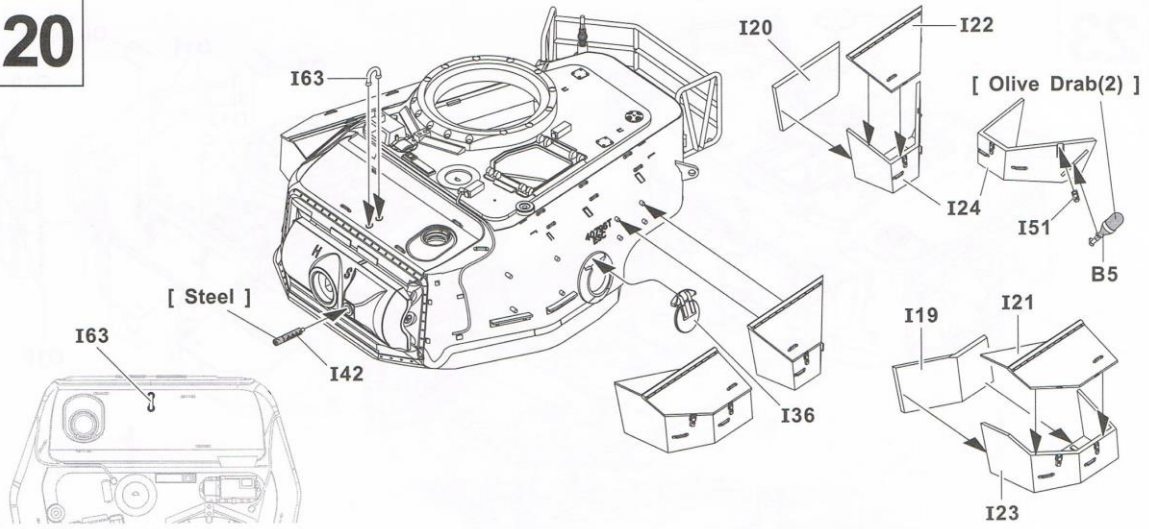

21

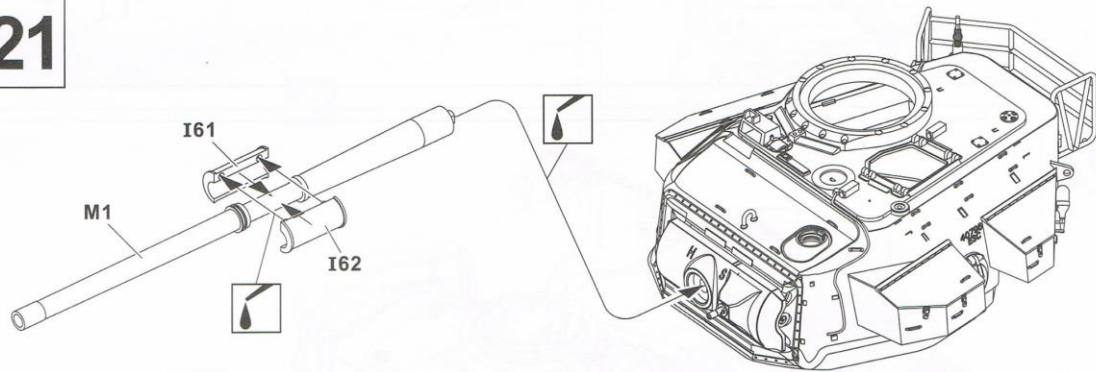

22

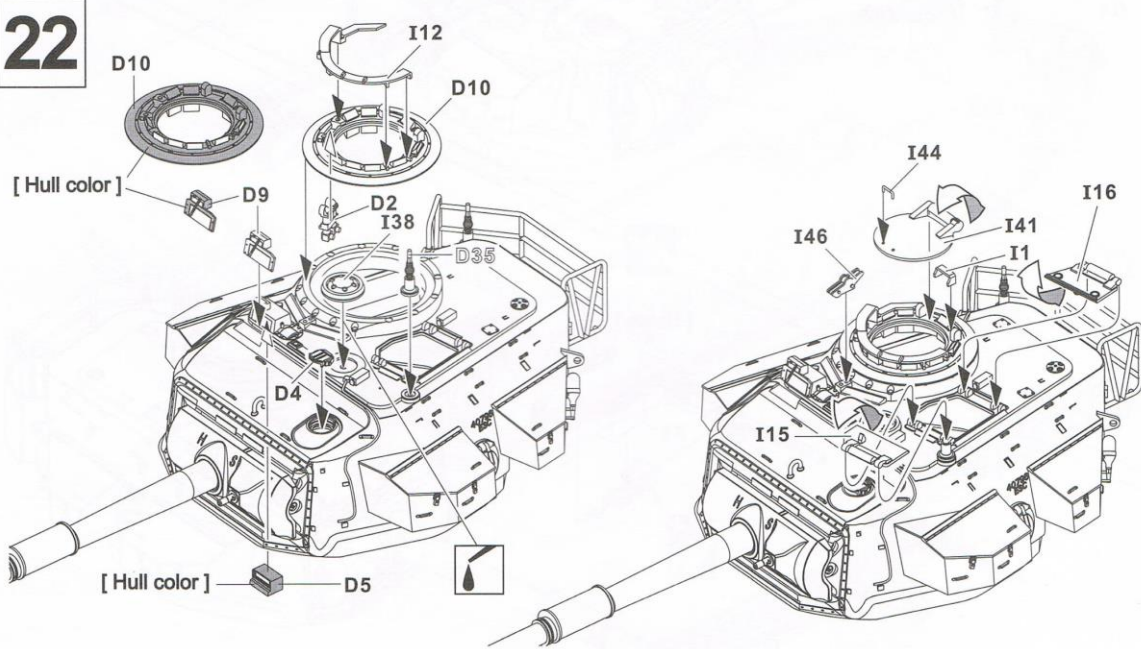

23

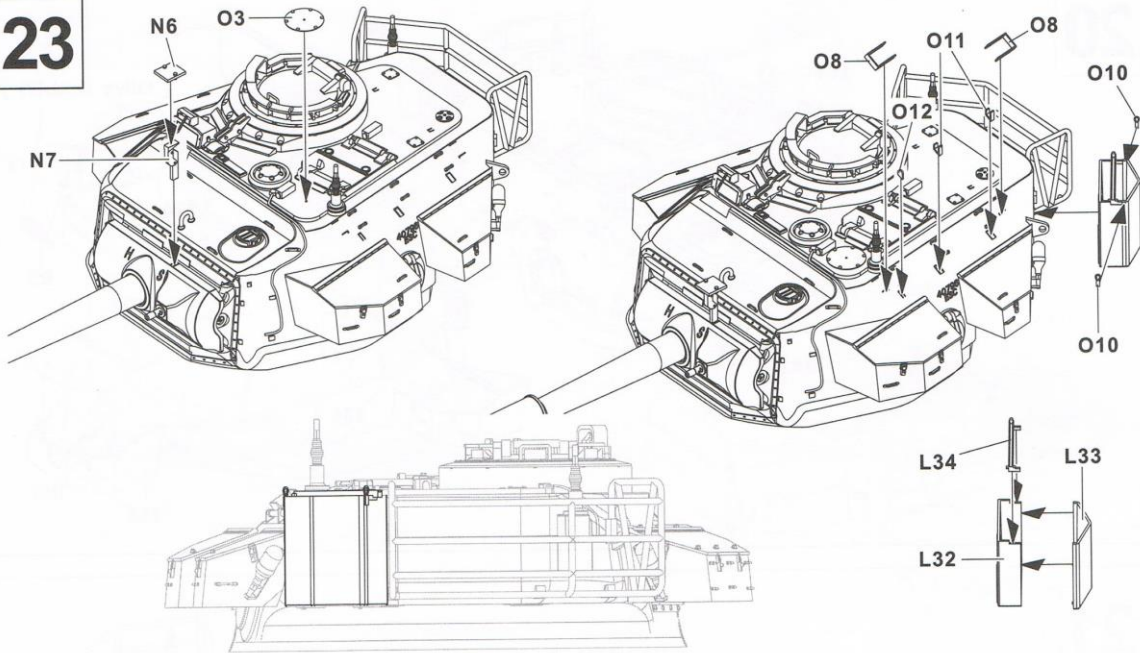

24

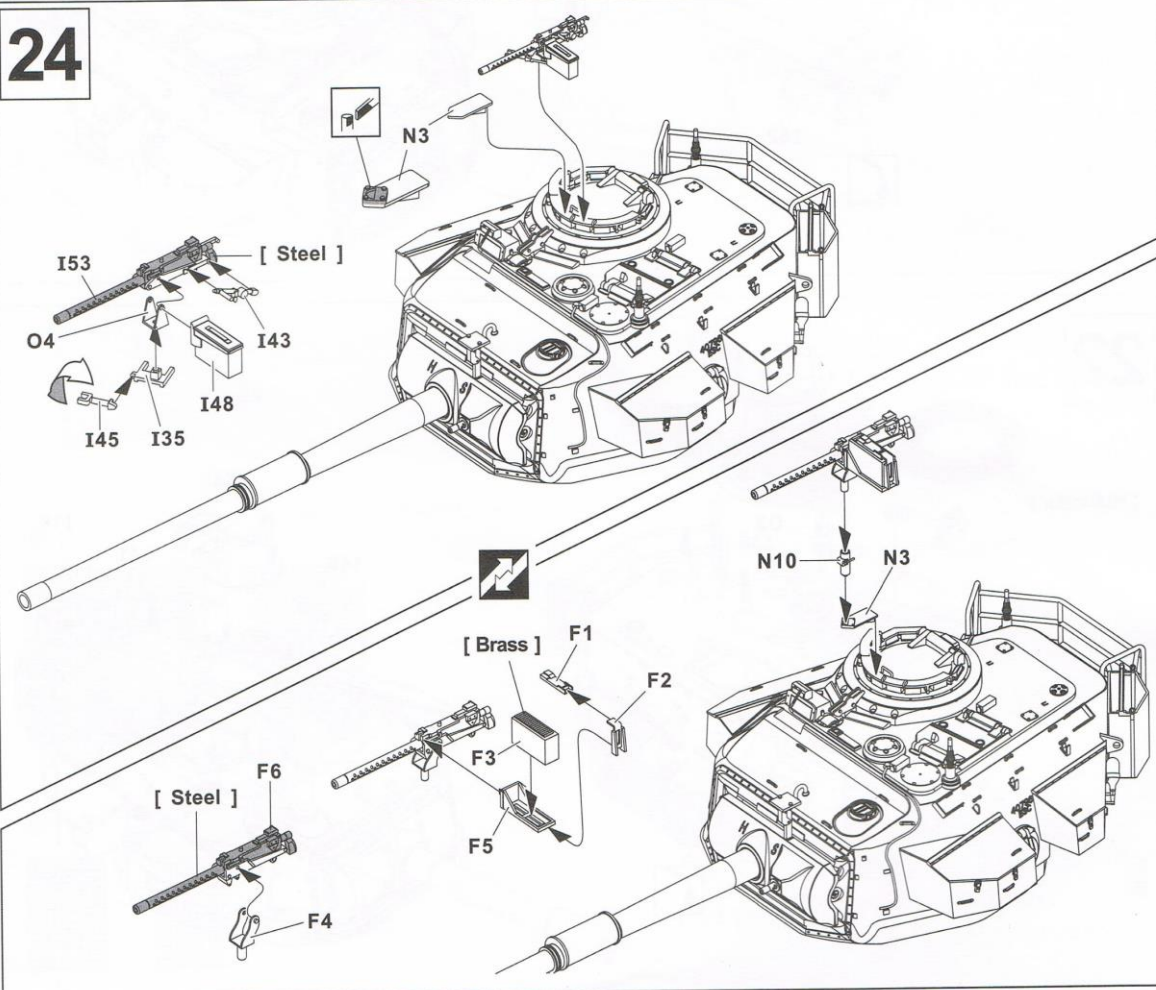

25

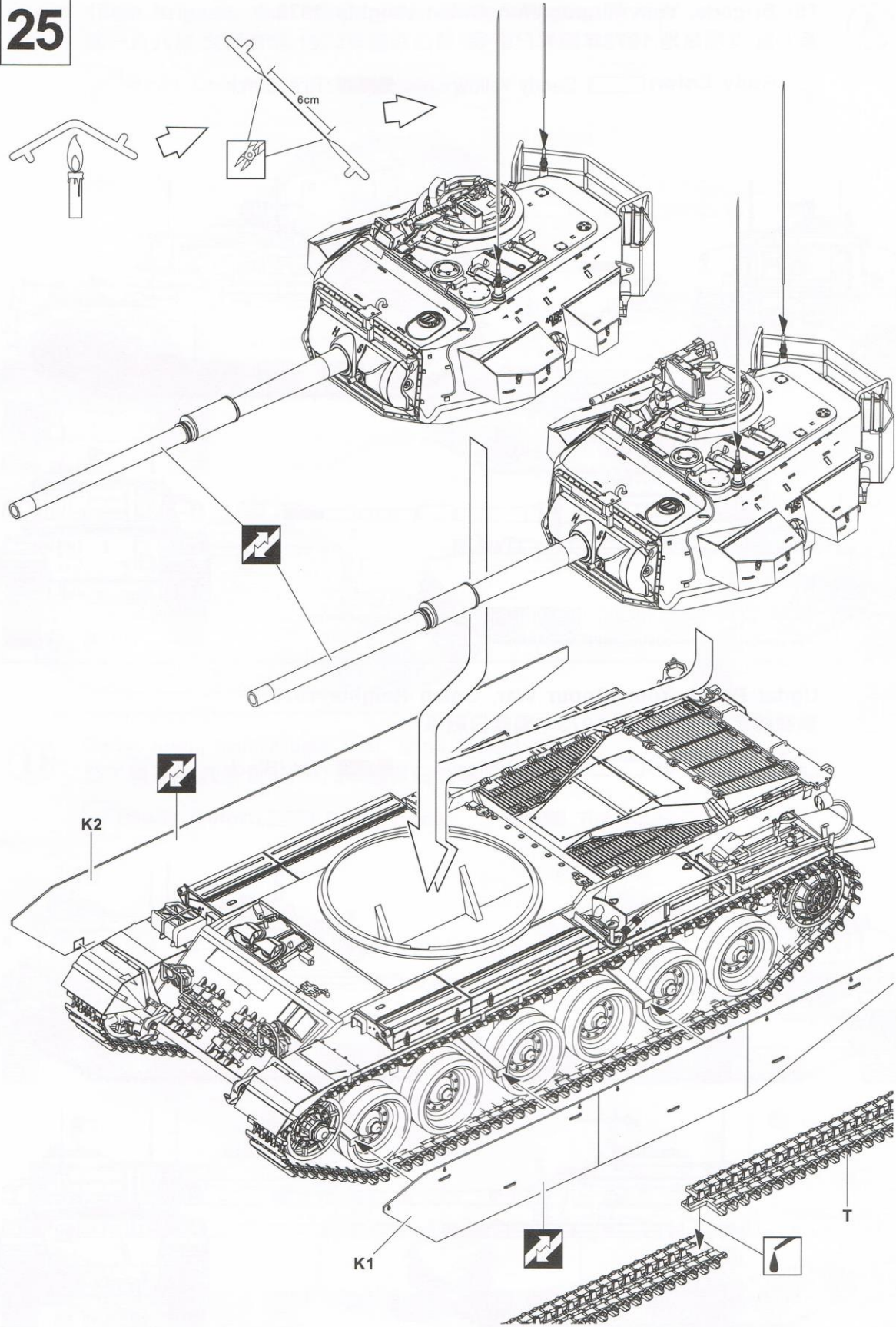

PARTS LIST 零件表

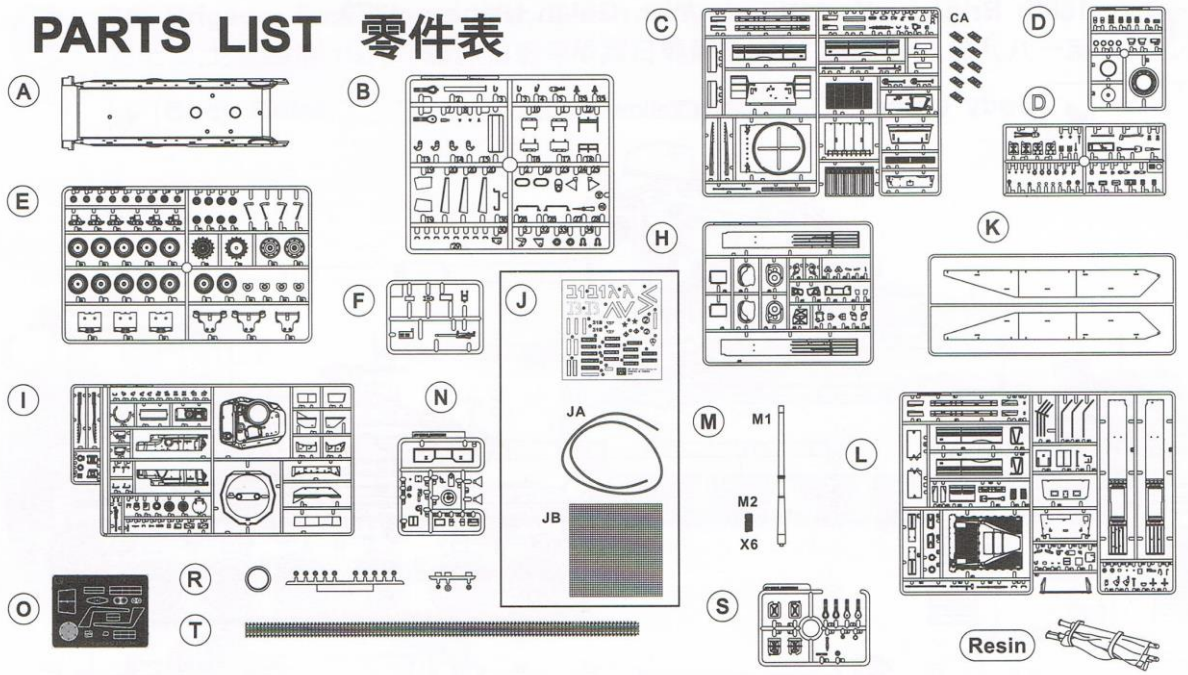



Parts :	(A) ——— 1	(E) ——— 2	(I) ——— 1	(N) ——— 1	(T) ——— 2
	(B) ——— 2	(F) ——— 1	(J) ——— 1	(R) ——— 24+2	Resin ——— 2
	(C) ——— 1	(H) ——— 1	(L) ——— 1	(S) ——— 2	(D) ——— 1
	(D) ——— 1	(O) ——— 1	(M) ——— 1	(K) ——— 1	

A

7th Brigade, Yom Kippur War, Golan Heights 1973.

第七旅, 戈蘭高地, 1973年贖罪日戰爭

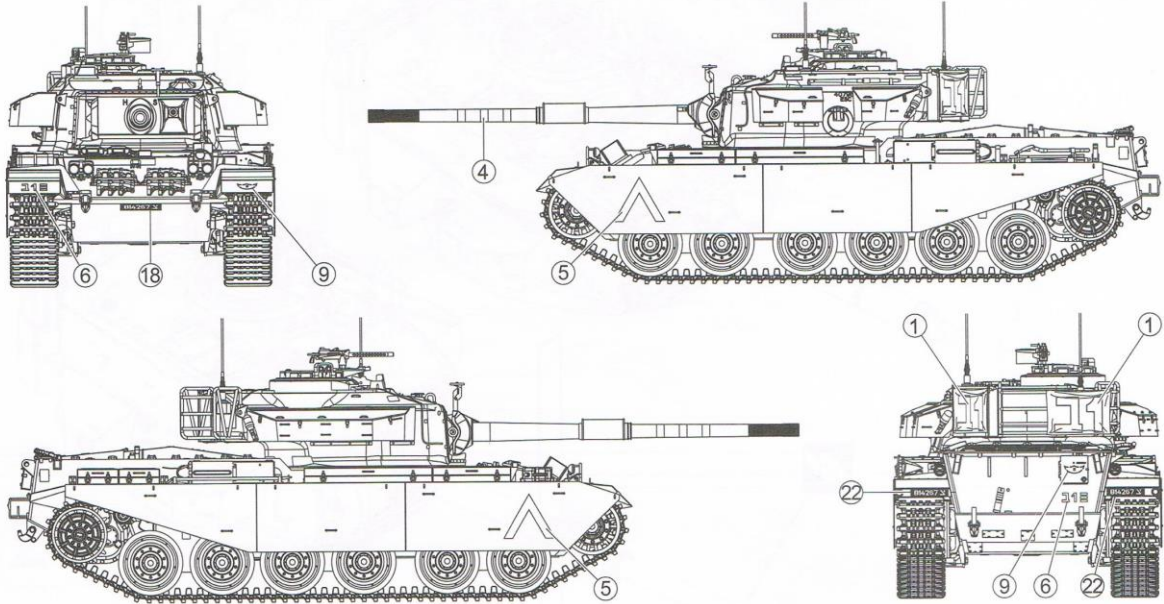

 **Body Color:**  Sandy Yellow  Tire Black



B

Ugdat Peled, Yom Kippur War, Golan Heights 1973.

裴勒將軍師, 戈蘭高地, 1973年贖罪日戰爭

 **Body Color:**  Sandy Yellow  Tire Black

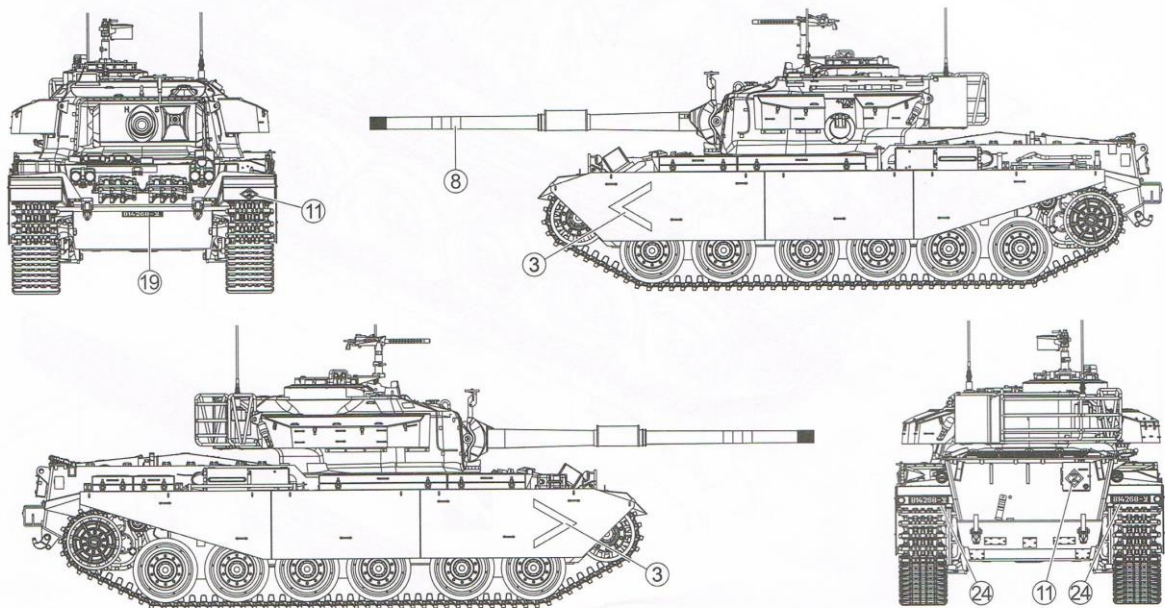

C

188th Brigade, Yom Kippur War, Golan Heights 1973.

第一八八旅, 戈蘭高地, 1973年贖罪日戰爭



Body Color: Sandy Yellow

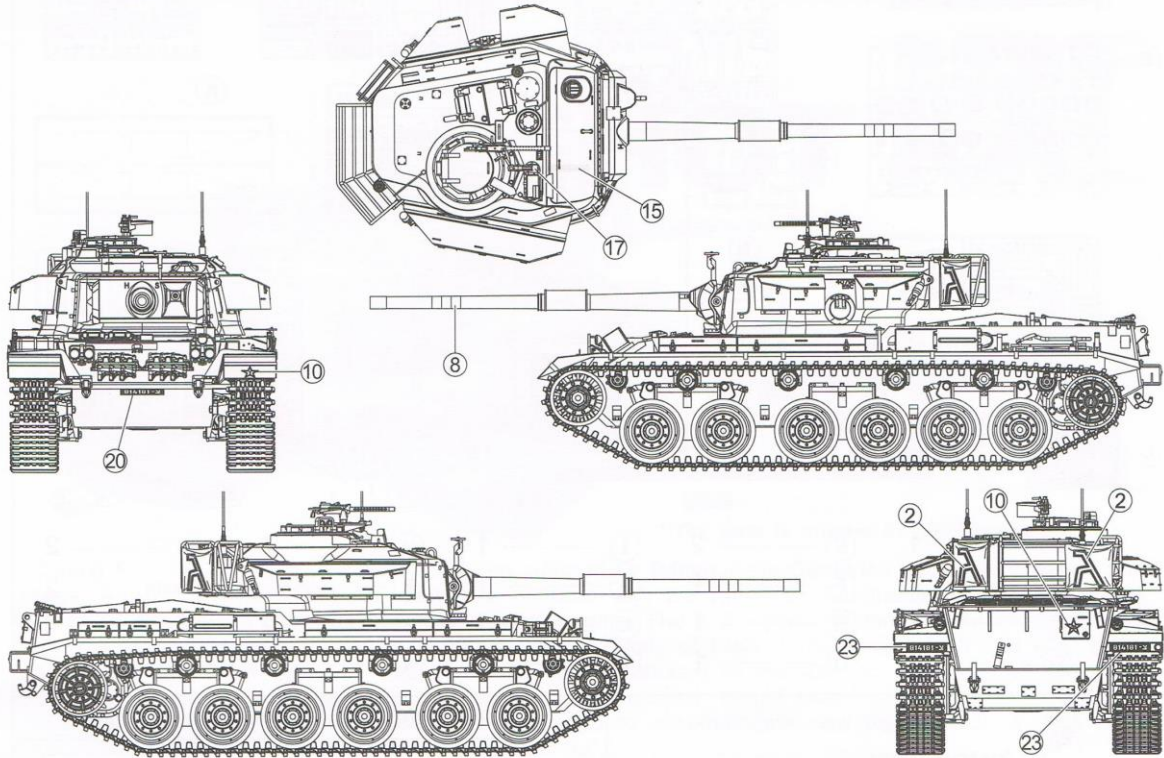

D

Ugdat Adan, Yom Kippur War, Sinai Desert 1973.

亞丁將軍師, 西奈沙漠, 1973年贖罪日戰爭



Body Color: Sandy Yellow

Tire Black

