

ENCORE

MODELS

FORMERLY RELEASED BY HELLER

1/72 Scale

Messerschmitt Bf 109G-2/5/6/Trop

1002

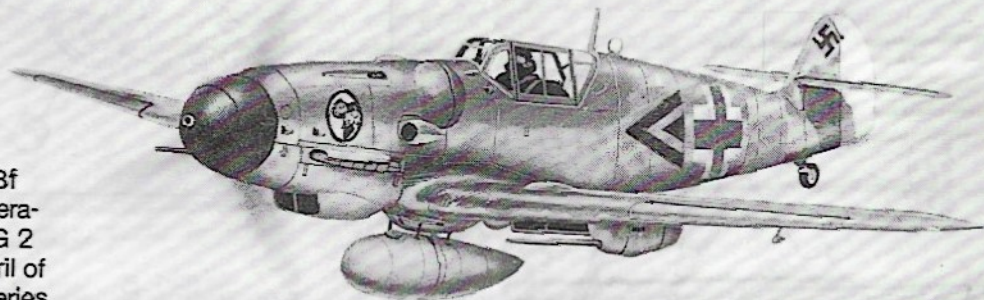
**History:**

The Messerschmitt Bf 109G-2 went into operational service with JG 2 Richtofen during April of 1942. The Bf 109G series was the most widely produced of the Messerschmitt 109 family with over 10,000 being built before the end of the war.

DATA:

- Weight: 6,900 pounds
- Length: 29 feet 7 $\frac{1}{8}$ inches
- Wing Span: 32 feet $\frac{1}{2}$ inch
- Speed: 386 mph
- Range: 620 miles
- Armament: One 20mm cannon and two 7.9mm machine guns (some aircraft carried additional 20mm cannons in underwing mounts).
- Powerplant: One 1,475 hp Daimler-Benz DB 605 liquid cooled engine.

STEP 1 PROPELLER ASSEMBLY

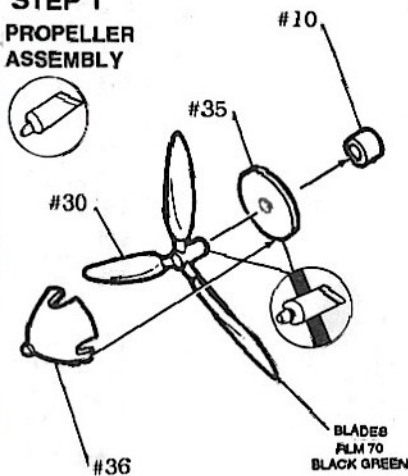

STEP 2 COCKPIT ASSEMBLY

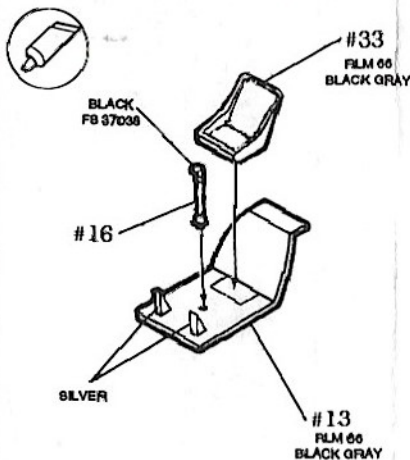

STEP 3 & 4 LANDING GEAR ASSEMBLY

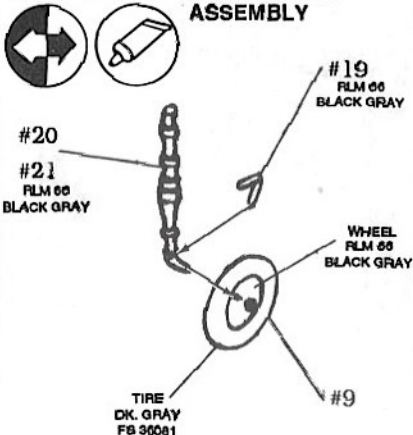

STEP 5 FUSELAGE ASSEMBLY

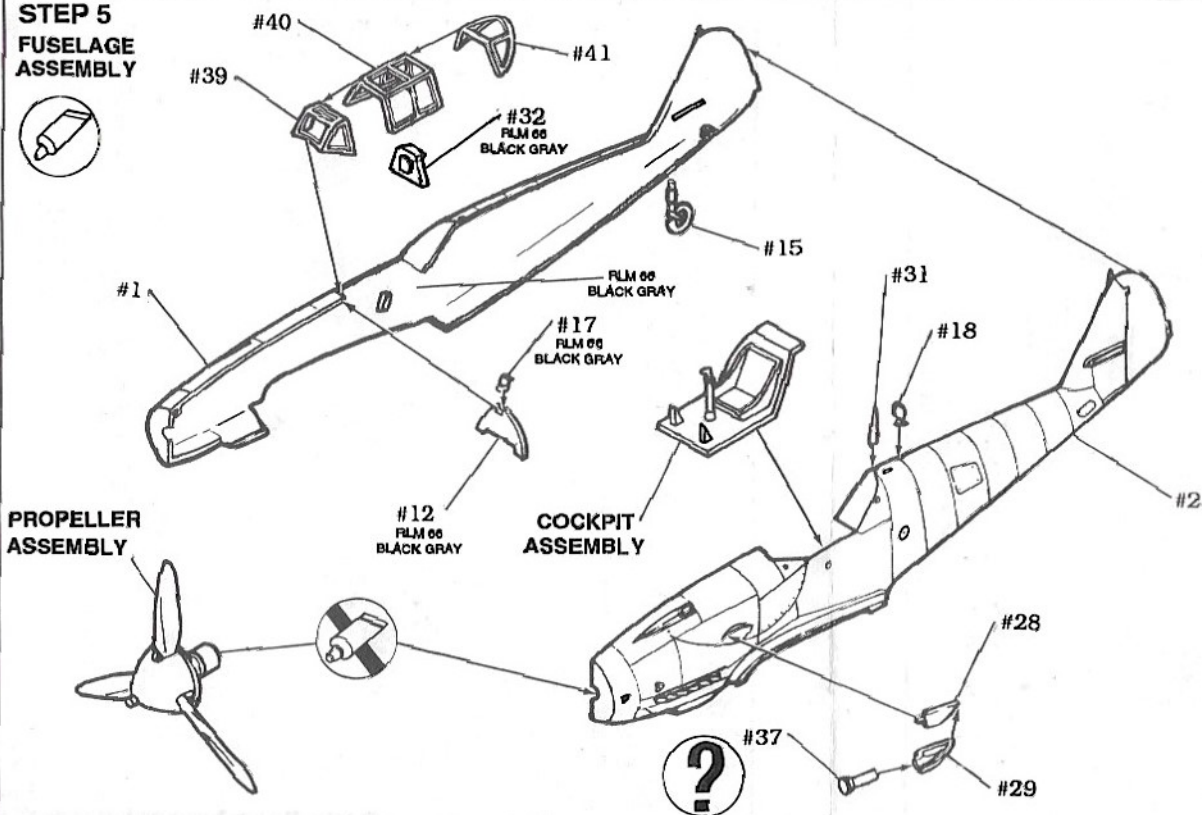

PROPELLER ASSEMBLY

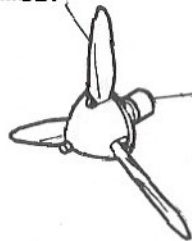

STEP 6 FINAL ASSEMBLY

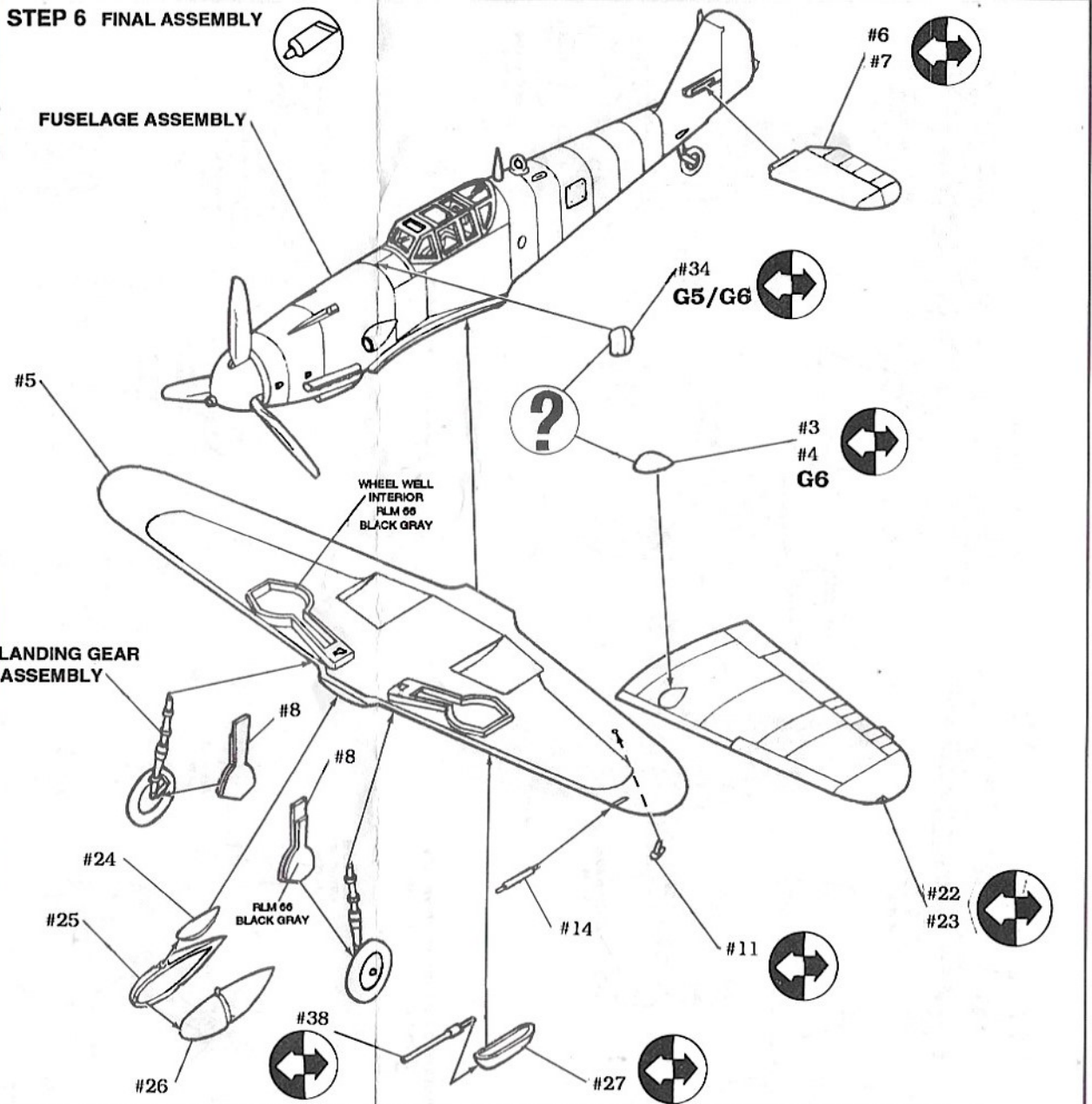

Assembly Legend

- | | | | | | | | | | |
|--|-----------------|--|-----------|--|---------------------|--|-------------|--|-------------|
| | Cement Together | | Remove | | Fill Hole | | Apply Decal | | Be Careful |
| | Do Not Cement | | Open Hole | | Repeat Right & Left | | Optional | | Add Ballast |

MESSERSCHMITT BF 109G-2
WILHELM CRINIUS

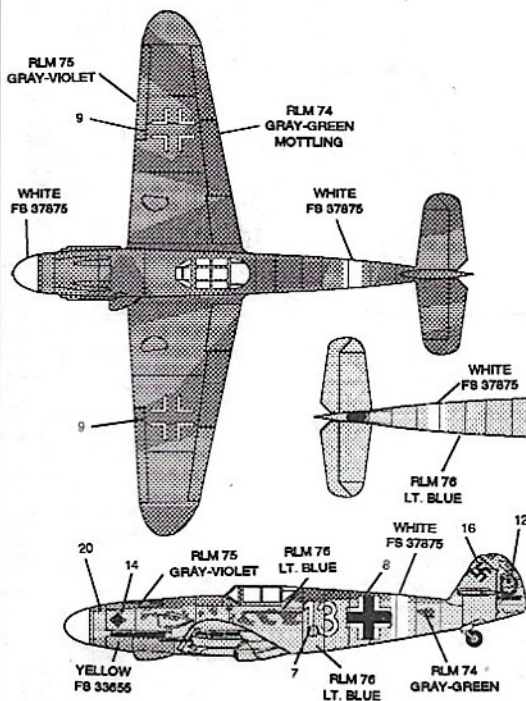

MESSERSCHMITT BF 109G-2

HEINRICH EHRLER
SEE AIRCOM AIRWAY N°11
PETSAMO FINLAND MARCH 1963

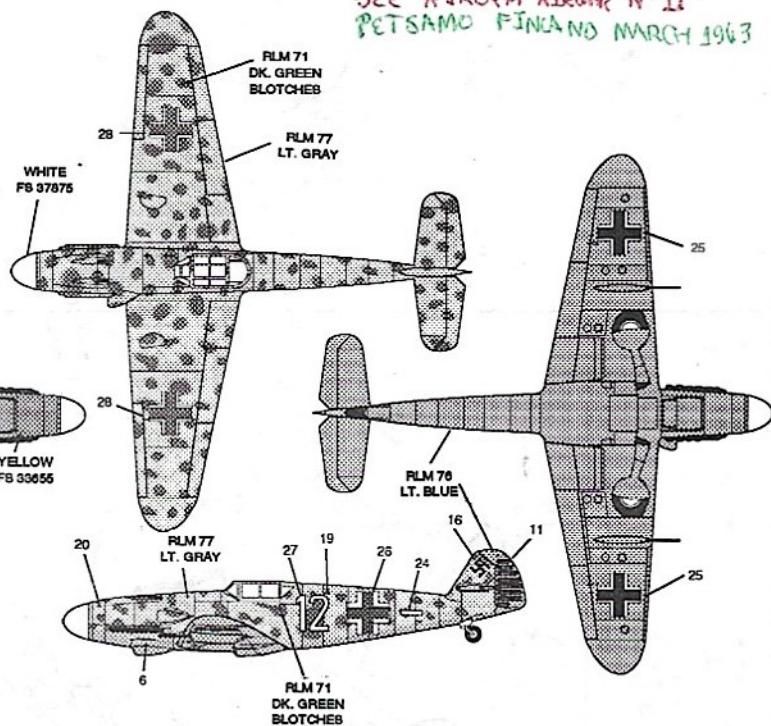

MESSERSCHMITT BF 109G-2 ⁵
GRUPPE KOMMANDER I/JG 27

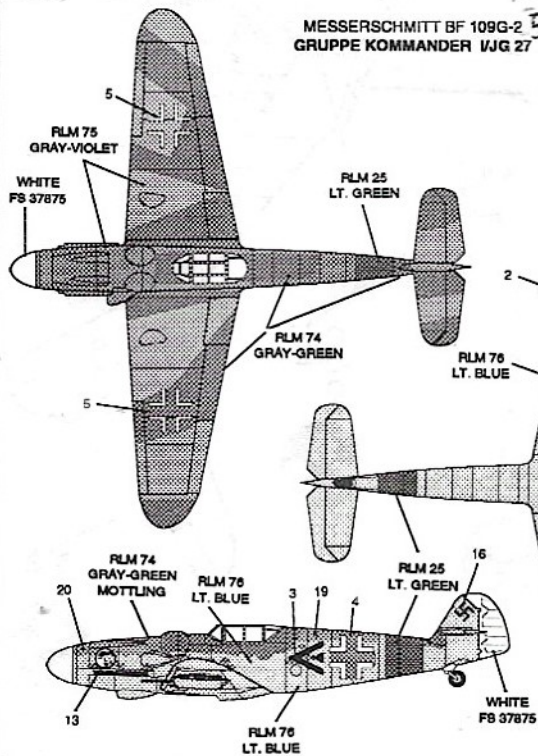

MESSERSCHMITT BF 109G-2 ⁵
HAUPTMANN CARGANICO, KOMM I/JG 5

