

F-4A-1, 8th Photographic Reconnaissance Squadron, 6th Photographic Reconnaissance Group, 5th Air Force, Port Moresby, 1943. Stroj byl později předán No.75 Sqn. RAAF.

F-4A-1, 8th Photographic Reconnaissance Squadron, 6th Photographic Reconnaissance Group, 5th Air Force, Port Moresby, 1943. Later handed over to No.75 Sqn. RAAF.



Odlévaný set / All resin set

4398  
1/48

F-4A-1 Recon Lightning Conversion Set

for Tamiya kit

www.cmkkits.com  
www.specialhobby.eu

Visit our official website and e-shop at

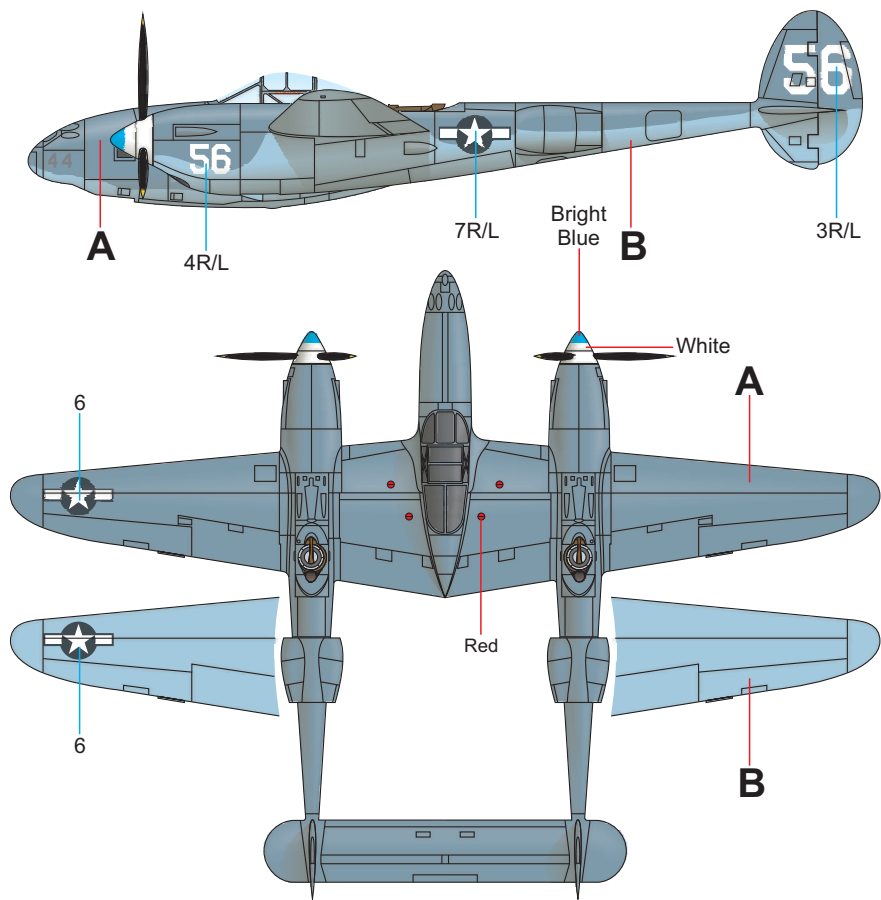

PUR - Polyurethane parts

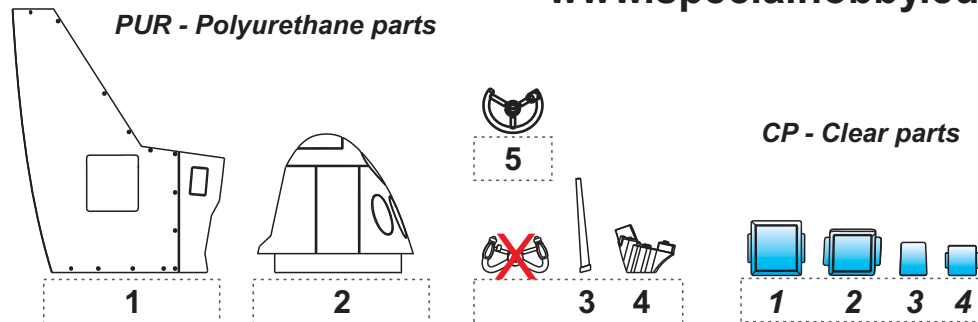

Decal

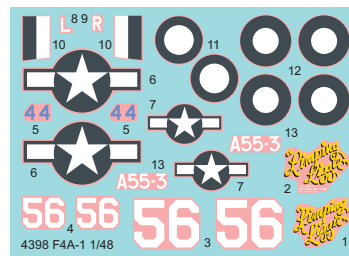

Mask



STEP 1

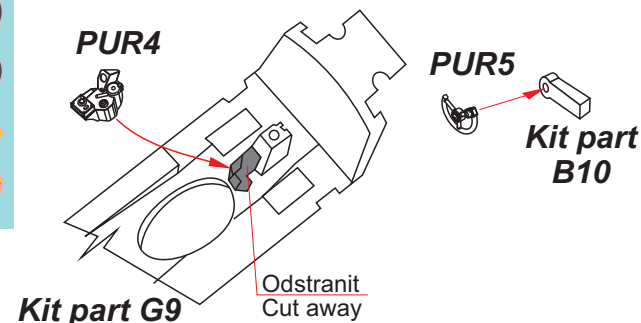

Dále postupujte dle návodu modelu Tamiya  
From this step on, follow the Tamiya kit instructions

Díly ohnuté popř. pokroucené vlivem teplotních změn a stárnutí materiálu, mohou být narovnány do požadovaného tvaru pomocí proudu teplé vody nebo vzduchu (hair dryer). Různé drátky a tyčky nejsou přiloženy. Kontaktní plochy doporučujeme před lepením omastit.

Parts slightly distorted and bent owing to temperature changes or due to material ageing can be straightened to requested shape by hot water or hot air jet (hair dryer). This process can be repeated till result is entirely satisfactory. Wires and rods not included. It is recommended to remove grease from contact areas

K lepení použít kyanoakrylátové lepidlo / For best gluing results use cyanoacrylate glue!

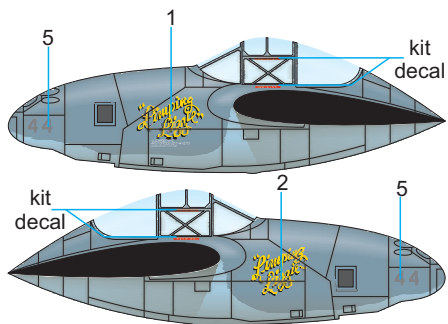

motorové gondoly - vnitřní strana  
inboard detail of the engine nacelles

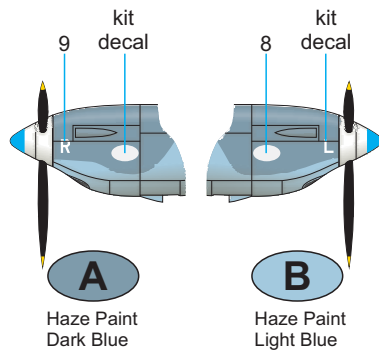

SYMBOLS					
	MOŽNOST VOLBY OPTIONAL NACH BELIEBEN OPTION		POUŽIT KYANOAKRYLÁTOVÉ LEPIDLO INSTANT CYANOACRYLATE GLUE ZYANOAKRYLATKLEBER ADHESIF CYANOACRYLAT		OHNOUT BEND BIEGEN COURBER
	ZHOTOVIT NOVĚ SCRATCH BUILD FERTIGSTELLEN ACHEVER		RĚZAT/VRTAT CUT OFF/DRIILL ENTFERNEN DETACHER		NATŘÍT COLOUR FARBEN PEINDRE

Producer: Special Hobby, Mezilesí 718, 193 00 Praha 9, Czech Republic

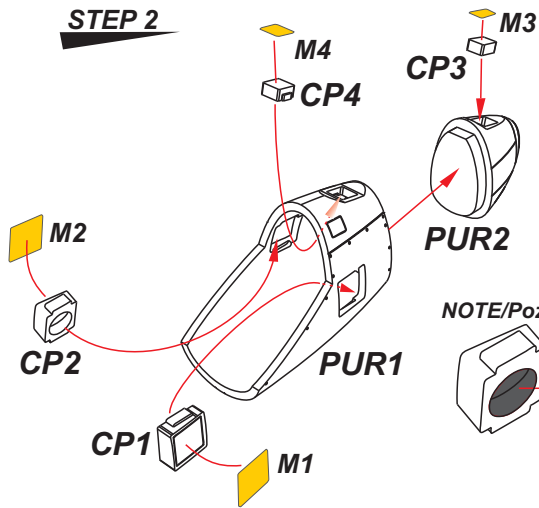
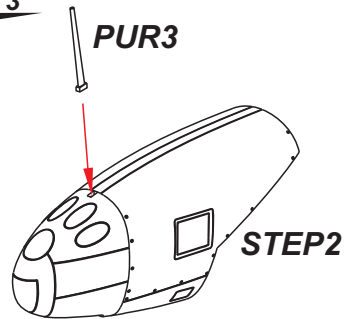
**STEP 2****STEP 3**

NOTE/Pozn.:

Zahloubení imitující objektivy kamer nabarvěte z vnitřní strany černou barvou  
Paint the embedded camera lenses with gloss black - on inside.

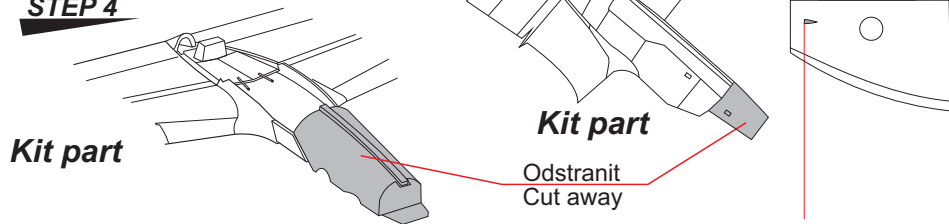
**STEP 4**

- Dále postupujte dle návodu modelu a slepte předřovou gondolu včetně podvozkové šachty

- When finished with Step 4, follow the kit instructions and assemble the fuselage nacelle including the front undercarriage bay.

Kit part

Odstranit  
Cut away

- na krytech motorů pod výfuky odstraňte z obou stran malé nasavače a jejich pozice zatmelte  
- small engine cowling air intakes on either side to be removed and their position filled with putty

**STEP 5**

- ztenčete z vnitřní strany, aby přečnívající díl podvozkové šachty nebránil přesnému dosednutí dílů  
- Sand thin on inside so that the protruding portion of wheel bay does not hamper perfect fit of the parts.

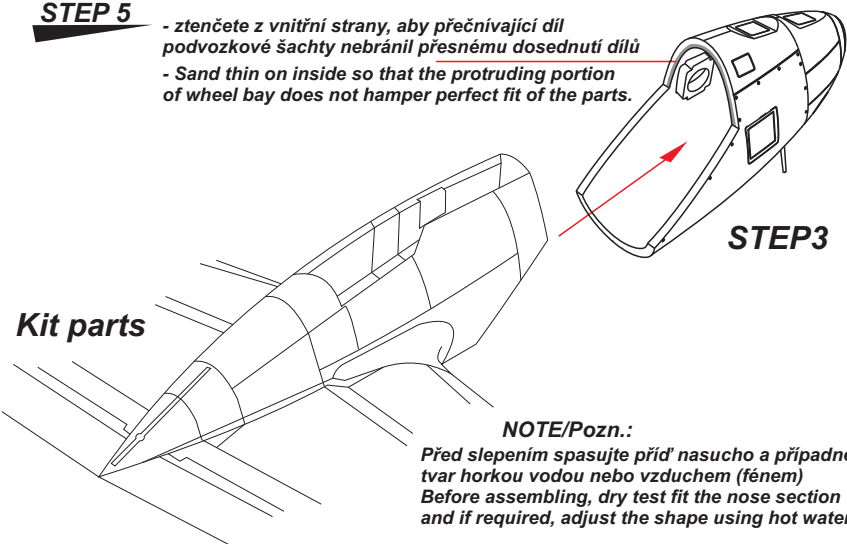

NOTE/Pozn.:

Před slepením spasujte předř nasucho a případně upravte tvar horkou vodou nebo vzduchem (fénem)  
Before assembling, dry test fit the nose section and if required, adjust the shape using hot water or hair dryer.

F-4A-1, No.1.PRU, RAAF, Coomalie Creek, severní Austrálie, únor až prosinec 1943. Stroj byl až do havárie v prosinci 1943 používán k dálkovému průzkumu protoru mezi Austrálií a Novou Guineou. Při těchto nebezpečných letech do kabiny usadili nejčastěji S/L Lawrie, F/L Robilliard, F/L Talberg a F/L Sinnott.

F-4A-1, No.1.PRU, RAAF, Coomalie Creek, Northern Territory of Australia, February - December 1943. Until its crash landing in December 1943, the machine had been used for long range reconnaissance of the area between Australia and New Guinea. At the controls during these perilous missions were most often S/L Lawrie, F/L Robilliard, F/L Talberg a F/L Sinnott.

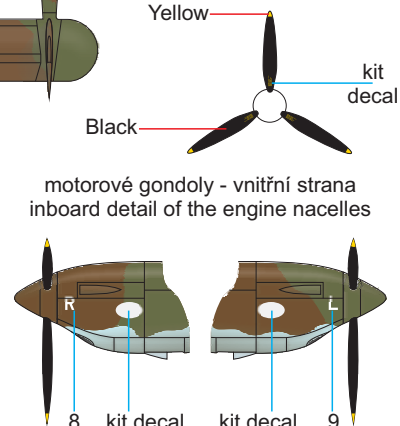
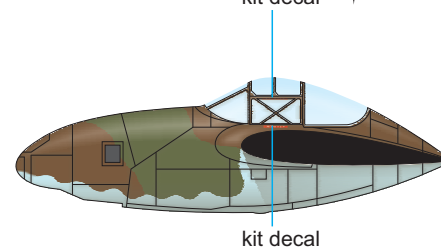
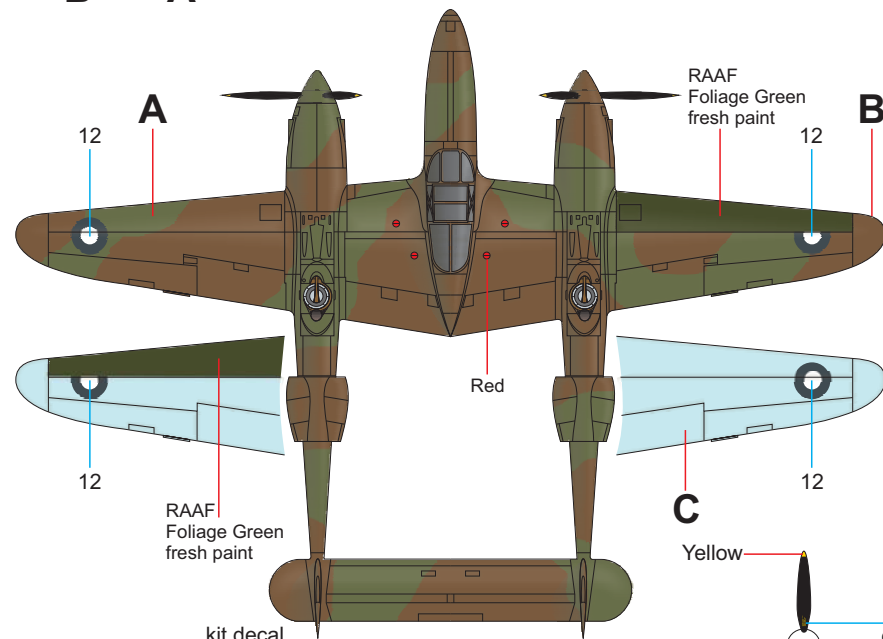
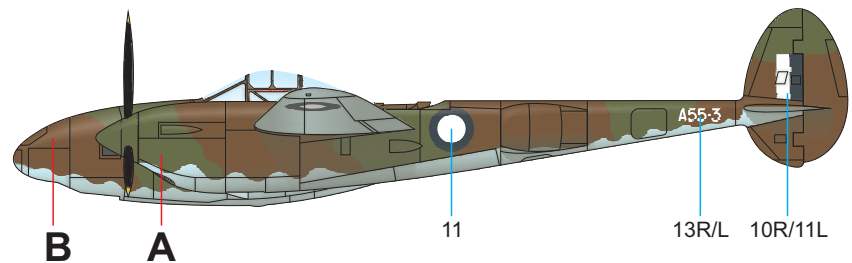

**A**  
RAAF  
Foliage Green

**B**  
RAAF  
Earth Brown

**C**  
RAAF  
Sky Blue