



1/48 SCALE MODEL CONSTRUCTION KIT

A11002

De Havilland Sea Vixen FAW.2

GB The Sea Vixen represents the zenith of DeHavilland's twin boom jet design philosophy. Entering service in 1959, the Sea Vixen was the first British fighter to be designed without guns, relying instead upon air to air missiles as its sole method of attack. Developed from the unsuccessful and infamous DH110, the Sea Vixen was the first swept wing, twin boom aircraft produced by DeHavilland and proved to be a capable all weather fighter, through two major variants, the FAW 1 and FAW 2. While the Sea Vixen saw no air to air combat, it was involved in some anti-insurgency work and shows of force in the

F Le Sea Vixen représente l'apogée de la philosophie de DeHavilland en matière de conception d'avion bipoutre à réaction. Entrant en service en 1959, il fut le premier avion de chasse britannique conçu sans canons, comptant plutôt sur ses missiles air-air pour son seul moyen d'attaque. Développé du DH110, victime d'un accident tragique, le Sea Vixen était le premier avion bipoutre aux ailes en flèche produit par DeHavilland ; ses variantes principales, le FAW 1 et le FAW 2, étaient des chasseurs tout temps très performants. Même si le Sea Vixen ne participa jamais aux combats aériens, il fut impliqué dans

D Mit der Sea Vixen erreichte DeHavilland in der Doppelrumpfkonstruktion einen einmaligen Höhepunkt. 1959 zum ersten Mal aktiv eingesetzt, war die Sea Vixen der erste britische Jäger, der nicht mit MGs oder Kanonen bewaffnet war; stattdessen war die Maschine ausschließlich mit Luft-Luft-Raketen für den Luftkampf bestückt. Auf dem Grundmodell der nicht erfolgreichen und berühmten DH110 basierend entwickelt, war die Sea Vixen das erste von DeHavilland gebaute doppelrumpfige Pfeilflügelflugzeug. In ihren Hauptvarianten FAW 1 und FAW 2 konnte sie sich als leistungsfähiger Allwetterjäger bewähren. Während die Sea Vixen zwar nie direkt in

E El Sea Vixen constituyó el cénit de la filosofía de diseño con doble viga de DeHavilland. Entró en servicio en 1959 y fue el primer caza británico sin cañones, utilizando misiles aire-aire como único sistema de ataque. Desarrollado a partir del desafortunado DH110, el Sea Vixen fue el primer aparato de alas en flecha y doble viga producido por DeHavilland y demostró ser un caza muy competente en todas las condiciones atmosféricas en sus dos principales variantes, FAW 1 y FAW 2. Aunque no entró nunca en combate aire-aire, participó en misiones contra la insurgencia y en demostraciones de fuerza en Oriente Medio,

S Sea Vixen representerar höjdpunkten i DeHavillands jetdesignsfilosofi med dubbel bom. Sea Vixen inledde sin tjänstgöring 1959 och var det första brittiska jaktplan som saknade kanoner till förmån för jaktrobotar som enda attackmetod. Sea Vixen, som utvecklades utifrån den föga framgångsrika och därför ökända DH110:an, var det första flygplanet med svept vinge och dubbel bom som producerades av DeHavilland och visade sig dessutom vara ett kapabelt allvädersjaktplan i form av de två huvudsakliga varianterna FAW 1 och FAW 2. Sea Vixen deltog inte i

Middle East, most notably over Aden and Kuwait.

The Sea Vixen was eventually replaced at sea by the F4 Phantom, but continued its service within the FAA as a target drone. Today, various Sea Vixens survive across the United Kingdom.

Length: 16.32m; wingspan: 15.54m; max speed: 690mph.

Armament: 4 x red top or fire streak missiles, 4 x MATRA rocket pods, 2 x 500lb bombs.

quelques opérations anti-insurrection et démonstrations de force au Moyen-Orient, notamment dans les cieux d'Aden et du Koweït.

Le Sea Vixen fut finalement remplacé sur porte-avion par le F4 Phantom mais continua d'être utilisé en tant que drone cible au sein de l'Aéronautique navale britannique. De nos jours, plusieurs Sea Vixen ont survécu au Royaume-Uni.

Longueur : 16,32 m ; envergure : 15,54 m ; vitesse maximale : 1.110km/h.

Armement : 4 missiles Red Top ou Fire Streak, 4 paniers à roquettes MATRA, 2 bombes de 230 kg.

Luftkämpfen geflogen wurde, wurde sie zu strategischen Diensten und zur Warnung von Feinden im Nahen Osten eingesetzt, vor allem über Aden and Kuwait.

Die Sea Vixen wurde schließlich zum Marine-Einsatz durch die F4 Phantom ersetzt, wurde jedoch weiterhin vom Fleet Air Arm der Royal Navy als Drohne verwendet. Heute existieren in Großbritannien noch mehrere verschiedene Sea Vixens.

Länge: 16,32 m; Spannweite: 15,54 m; Höchstgeschwindigkeit: 1.110 km/h;

Bewaffnung: 4 Red Top oder Firestreak Flugabwehrkörper, 4 MATRA Raketenwerfer, 2 Bomben (230 kg).

principalmente sobre Adén y Kuwait.

El Sea Vixen sería sustituido en el mar por el F4 Phantom, pero continuó en servicio en la FAA como avión robot teledirigido. En la actualidad aún se encuentran varios Sea Vixen en distintos puntos del Reino Unido.

Longitud: 16,32m; envergadura: 15,54m; velocidad máxima: 1110km/h.

Armamento: 4 misiles Red Top o Firestreak, 4 lanzacohetes MATRA, 2 bombas de 230kg.

några direkta flygstrider, men var inblandat i vissa antiinfiltrerings- och avskräckningsflygningar i Mellanöstern, speciellt över Aden och Kuwait.

Sea Vixen ersattes så småningom till sjöss av F4 Phantom, men fortsatte sin tjänstgöring som målrobot med FAA. Idag kan man fortfarande få syn på några överlevande Sea Vixen-plan i Storbritannien.

Längd: 16,32 meter; vingspann: 15,54 meter; maximal hastighet: 1 110 km/h.

Beväpning: 4 x "red top"- eller "fire streak"-missiler, 4 x MATRA-raketgondoler, 2 x 230-kilosbomber.

PLEASE NOTE : Some parts in the kit may not be required to build the model.

Assembly Instructions

GB Study drawings and practice assembly before cementing parts together. Carefully scrape plating and paint from cementing surfaces. All parts are numbered. Paint small parts before assembly. To apply decals cut sheet as required, dip in warm water for a few seconds, slide off backing into position shown. Use in conjunction with box artwork. Not appropriate for children under 36 months of age, due to the presence of small detachable parts.

F Étudier attentivement les dessins et simuler l'assemblage avant de coller les pièces. Gratter soigneusement tout revêtement ou peinture sur les surfaces à coller avant collage. Toutes les pièces sont numérotées. Peindre les petites pièces avant l'assemblage. Pour coller les décalques, découper le motif, le plonger quelques secondes dans de l'eau chaude puis le poser à l'endroit indiqué en décollant le support papier. Utiliser en même temps les illustrations sur la boîte. Ne convient pas à un enfant de moins de 36 mois – présence de petits éléments détachables.

D Vor Verwendung des Klebers Zeichnungen studieren und Zusammenbau üben. Farbe und Plattierung vorsichtig von den Klebeflächen abkratzen. Alle Teile sind nummeriert. Vor Zusammenbau kleine Teile anmalen. Um die Abziehbilder aufzukleben, diese ausschneiden, kurz in warmes Wasser tauchen, dann abziehen und wie abgebildet aufkleben. In Verbindung mit Abbildungen auf Schachtel verwenden. Ungeeignet für Kinder unter 36 Monaten. Kleine Teilchen vorhanden die sich lösen können.

E Estudiar los dibujos y practicar el montaje antes de pegar las piezas. Raspar cuidadosamente el plateado y la pintura en las superficies de contacto antes de pegar las piezas. Todas las piezas están numeradas. Es conveniente pintar las piezas pequeñas antes de su montaje. Para aplicar las calcomanías, cortar la hoja, sumergir en agua tibia durante unos segundos y deslizarlas en la posición debida. Ver ilustraciones en la caja. No conviene a un niño menor de 36 meses, contiene pequeñas piezas que pueden soltarse.

S Studera bilderna noggrant och sätt ihop delarna innan du limmar ihop dem. Skrapa noggrant bort förtkromning och färg från limmade delar. Alla delarna är nummerade. Mala smadelarna före ihopsättning. Fastsättning av dekaler, klipp ark. Doppa i varmt vatten några sekunder, låt baksidan glida på plats som bilden visar. Används i samband med kartongens handlitografi. Rekommenderas ej för barn under 3 år. Innehåller löstgbara smadelar.

I Studiare i disegni e praticare il montaggio prima di unire insieme i pezzi con l'adesivo. Raschiare attentamente le tracce di smalto e cromatura dalle superfici da unire con adesivo. Tutti i pezzi sono numerati. Colorare i pezzi di piccole dimensioni prima di montarli. Per applicare le decalcomanie, tagliare il foglio secondo il caso, immergere in acqua calda per alcuni secondi, quindi sfilare la decalcomania dalla carta di supporto e piazzarla nella posizione indicata. Usare in congiunzione con l'illustrazione sulla scatola. Non adatto ad un bambino di età inferiore ai 36 mesi dovuto alla presenza di piccoli elementi staccabili.

NL Tekeningen bestuderen en delen in elkaar zetten alvorens deze te lijmen. Metaalcoating en lak voorzichtig van lijmvlakken af schrapen. Alle delen zijn genummerd. Kleine delen vóór montage verven. Voor aanbrengen van stickers, gewenste stickers uit vel knippen, een paar seconden in warm water dompelen en dan van schutblad af op afgebeelde plaats schuiven. Hierbij afbeelding op doos raadplegen. Niet geschikt voor kinderen onder 3 jaar, omdat kleine deeltjes gemakkelijk kunnen losraken.

DK Tegningerne bør studeres, og man bør øve sig i monteringen, før delene limes sammen. Pladestykker og maling skal omhyggeligt fjernes fra klæbeoverfladerne. Alle dele er nummererede. Små dele skal males før monteringen. Overføringsbillederne anvendes ved at tilklippe arket efter behov. Og dyppe det i varmt vand i nogle få sekunder. Underlaget glides af og anbringes i den viste position. Påføres ifølge brugsanvisningerne på æsken. Ikke til børn under 3 år, forekomst af små løse elementer.













P Estudar atentamente os desenhos e experimentar a montagem. Raspar cuidadosamente as superfícies de modo a eliminar pintura e revestimento antes de colar. Todas as peças estão numeradas. Pintar as pequenas peças antes de colar. Para aplicar as decalcomanias, cortar as folhas e mergulhar em água morna por alguns segundos, depois deslizar e aplicar no respectivo lugar, como indicado nas ilustrações na caixa. Não convém a uma criança de menos de 36 meses devido à presença de pequenos elementos destacáveis.

SF Tutustu piirroksiin ja harjoittele kokoamista ennen kuin liimaat osat yhteen. Raaputa metallipäälyste ja maali varovasti pois liimattavilta pinnolta. Kaikki osat on numeroitu. Maalaa pienet osat ennen kokoamista. Siirtokuvien kiinnittämiseksi leikkaa ne arkista tarpeen mukaan. Kasta kuva lämpimään veteen muutaman sekunnin ajaksi, anna takapuolen liukua kuvalle osoitettuun kohtaan. Käytetään yhdessä laatikon kuvituksen kanssa. Ei suositella alle kolmivuotiaalle lapsille. Paljon irrotettavia pikkuosia.

PL Przed przystąpieniem do sklejania przestuduj uważnie rysunki i przećwicz składanie części. Ostrożnie zeskrub ze sklejanym powierzchni powłokę i farbę. Wszystkie części są ponumerowane. Drobne części pomaluj przed ich złożeniem. Celem przeniesienia odbitki wytnij ją z arkusza, zanurz na kilka sekund w letniej wodzie i zsuń z podłoża na wymagane miejsce. Używaj w połączeniu ze wzorami na pudełku. W związku z obecnością wielu drobnych, rozbielanych części, nie stosowne dla dzieci poniżej 3 lat.

GR Μελετήστε προσεκτικά τα σχέδια και συναρμολογήστε για πρώτη φορά τα κομμάτια χωρίς να τα κολλήσετε. Αφαιρέστε ξυπόνοτας επιμελώς πριν κολλήσετε οποιοδήποτε υλικό από τις επιφάνειες. Χρωματίστε τα μικρά κομμάτια πριν από τη συναρμολόγηση. Για να κολλήσετε τις χαλκομανίες, κόψτε γύρω γύρω το σχέδιο, βυθίστε το μερικά δευτερόλεπτα σε ζεστό νερό και μετά τοποθετήστε το στη θέση που υποδεικνύεται, αφαιρώντας την καλυπτική μεμβράνη. Λάβετε υπόψη σας ταυτόχρονα την εικονογράφηση του κουτιού. Ακατάλληλο για παιδιά ηλικίας κάτω των 36 μηνών. Υπάρχουν μικρά κομμάτια που αποσπώνται.

ASSEMBLY ICON INSTRUCTIONS

| | | | | | | |
|------------------------------------------------------------------------------------------------------------------------------------------------------------------------------------------------------------------------------------------------------------------------------------------------------------------------------|-------------------------------------------------------------------------------------------------------------------------------------------------------------------------------------------------------------------------------------------------------------------------------------------------------------------|--------------------------------------------------------------------------------------------------------------------------------------------------------------------------------------------------------------------------------------------------------------------------------------------------|-------------------------------------------------------------------------------------------------------------------------------------------------------------------------------------------------------------------------------------------------------------------------------------------------------------------------------------------|--------------------------------------------------------------------------------------------------------------------------------------------------------------------------------------------------------------------------------------------------------|-------------------------------------------------------------------------------------------------------------------------------------------------------------------------------------------------------------------------------------------------------------------------------------------------------------------------------------------------------------------------------------------|---------------------------------------------------------------------------------------------------------------------------------------------------------------------------------------------------------------------------------------------------------------------------------------------------------------------------------------------------------------------------------------|
| <p>Assembly phase Phase de montage Montagephase Fase de montaje Montering Fase di montaggio Montagefase Monteringsfase Fase de montagem Kokoamisvaihe Faza sklądania Φάση συναρμολόγησης</p>  | <p>Cement Coller Kleben Incollare Liimaa Pegar Lijmen Limma Kibe Colar Kleic Συγκόλληση</p>  | <p>Do not cement together Ne pas coller Nicht kleben Non incollare Limmaa inte No pegar Niet lijmen Ajá liima Skal ikke kibe Não collar Nie kleić Μη κολλάτε</p>  | <p>Symmetrical assembly Montage symétrique Symmetrischer Aufbau Montaggio simmetrico Montaje simétrico Symmetrische montage Symmetrinen asentaminen Symmetrisk monterung Symmetrisk saming Montagem simétrica</p>  | <p>Alternative part(s) provided Choix Auswahlmöglichkeit Sceita Val Eleccin Keuze Valinta Valg Op o Wybr Επιλογή</p>  | <p>Repeat this operation Répéter l'opération Vorgang wiederholen Ripetere l'operazione Utr ingreppet p nytt Repètir la operacin De verrichting herhalen Toista toimenpite Manvren gentages Repètir a opera o Powtży c operacj Επανάληψη διαδικασίας</p>  | |
| <p>Decals Decalcomanias Abziehbild Decalcomanie Dekalkomanier Calcomanias Bildöverfring Decalcomania Dekalkomanie Χαλκομανίες</p>  | <p>Crystal part Pice cristal Kistalteil Pieza cristal Kristalldel Pezzo cristallo Kristallen onderdeel Kryształowyk Pea de cristal Lasiosa Część kryształowa Διαφανές κομμάτι</p>  | <p>Weight Lester Beschweren Zavorrre Sit barlast Lastrar Ballasten Aseta vastapaino Forsyne med ballast Lastrar Obciążyc balastem Έρμα</p>  | <p>Join by applying heat Riveter Heiss vernieten Ribadire Klinken Nita Niittaa Fastnitte Rebitar</p>  | <p>Drill or pierce Percer Bohren Forare Borra Agujerear Boren Livist Gennembore Furar Przebic Τρυπημα</p>  | <p>Cut Decouper Schneiden Cortar Klipp Tagliare Knippen Klip Cortar Leikkaa Przeciac Αποκόψατε</p>  | <p>Humbrol paint number N° peinture Humbrol Humbrol-Farbnr N° pintura Humbrol Humbrol farg nr N° vernice Humbrol Humbrol-vernummer Humbrol-malingsnummer N° de pintura Humbrol Humbrol-maalinn numero N° farby Humbrol Νούμερο χρωματος Humbrol</p>  |

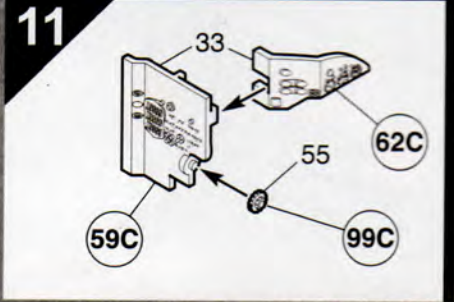
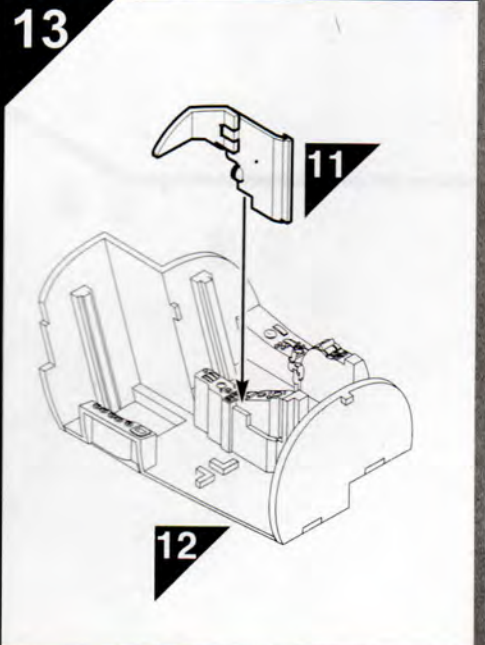
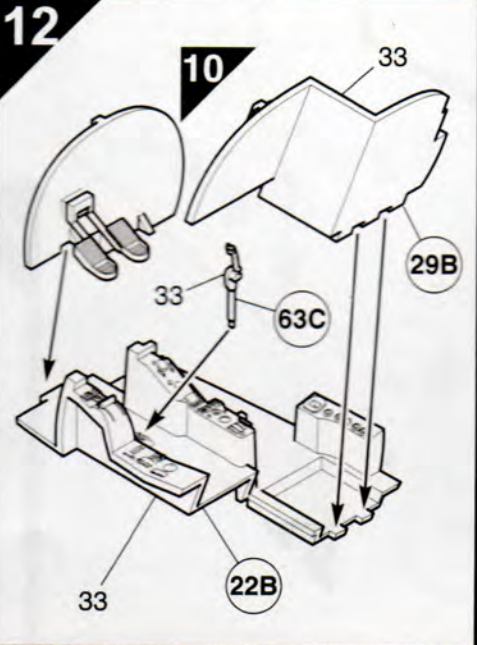
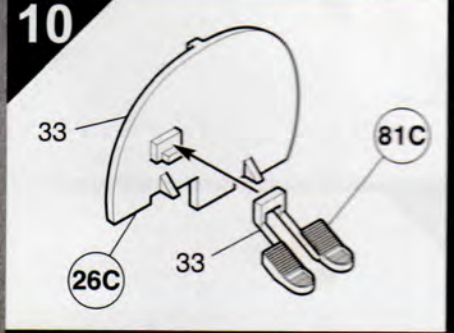
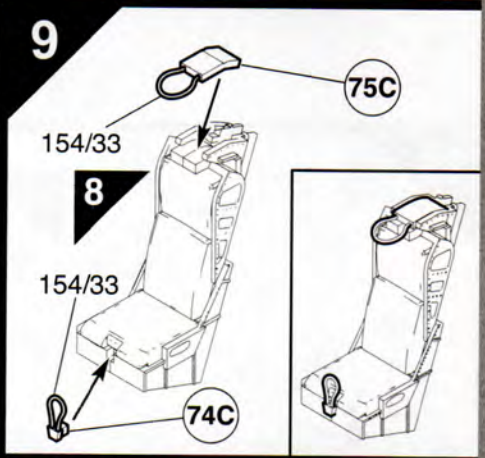
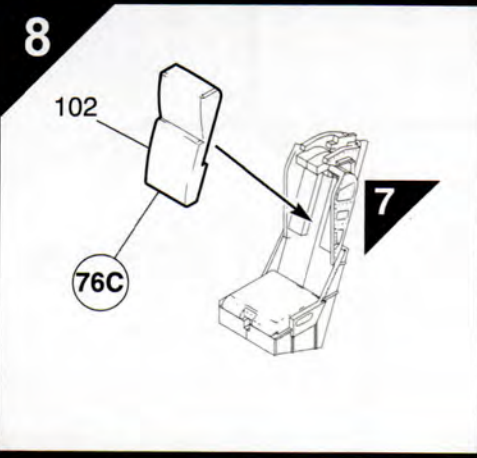
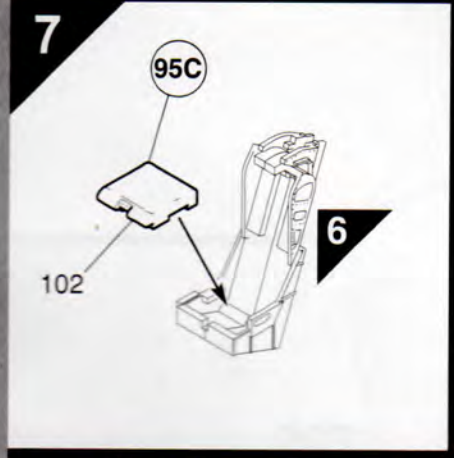
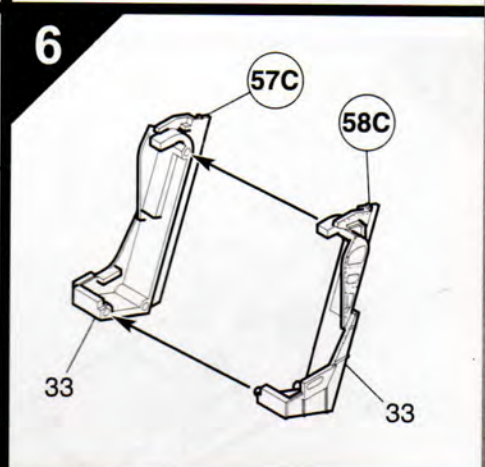
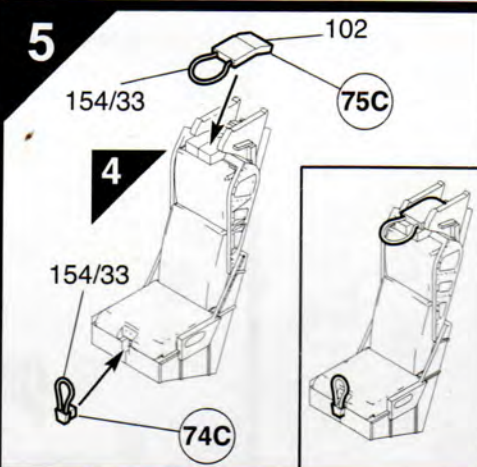
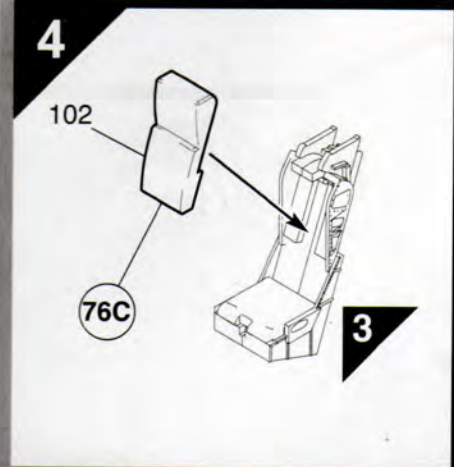
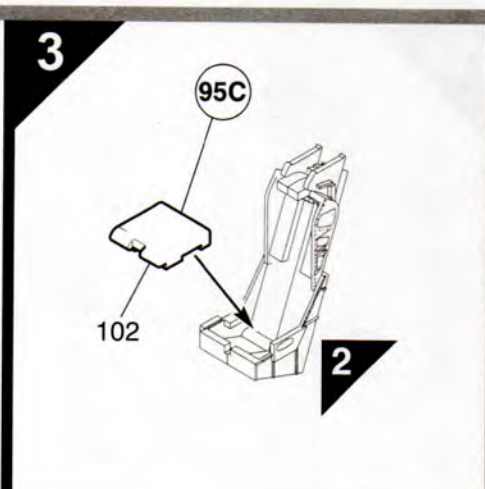
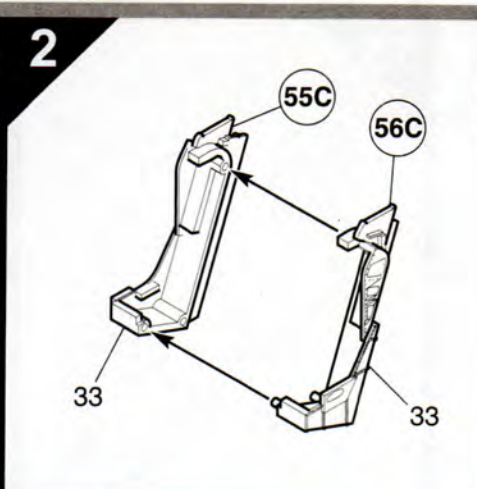

14

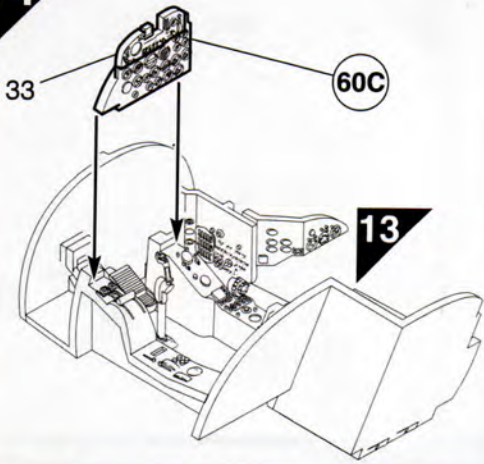

15

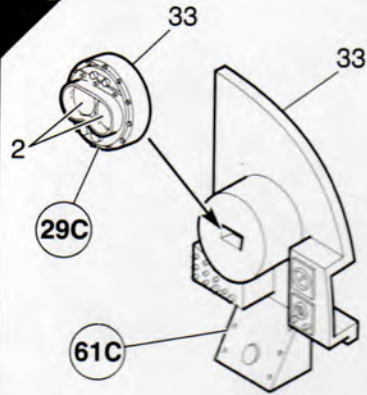

16

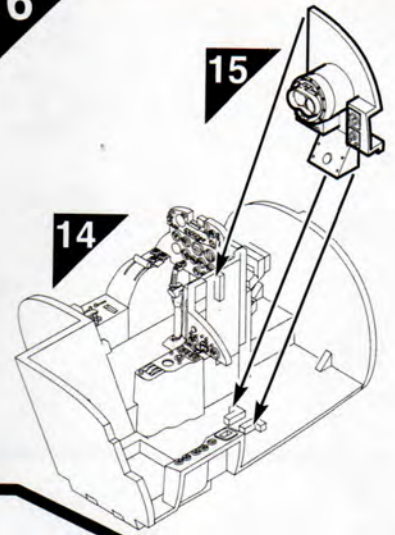

17

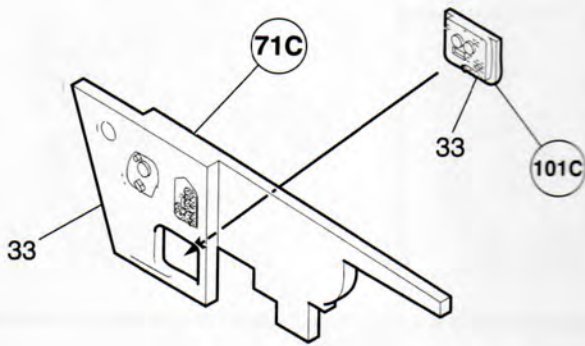

18

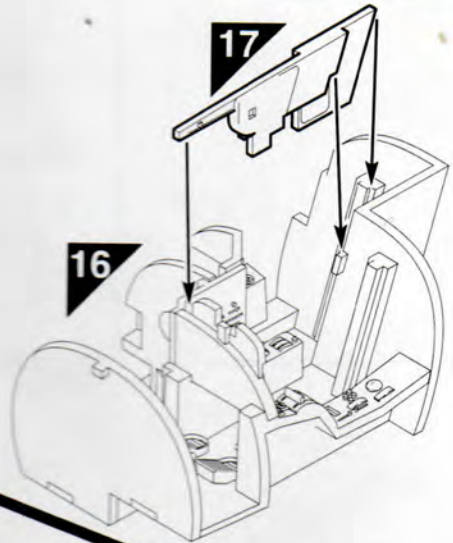

19

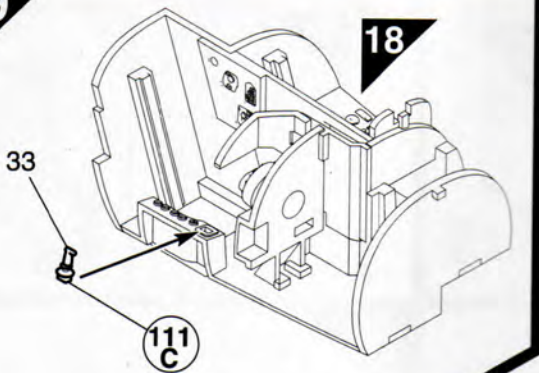

20

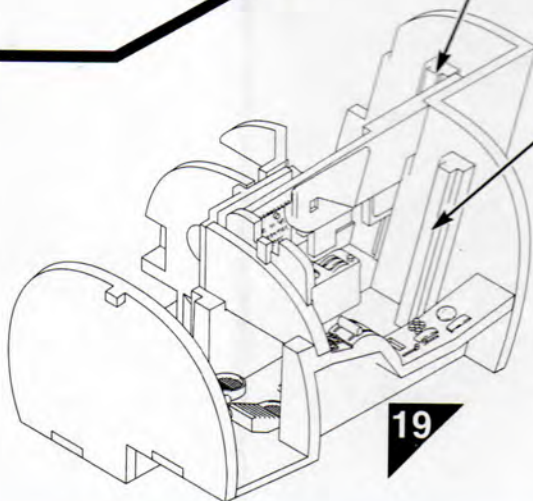
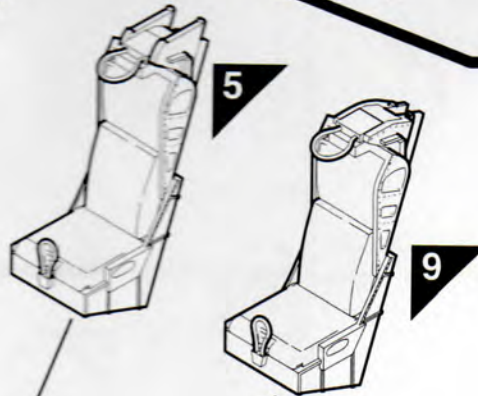

21

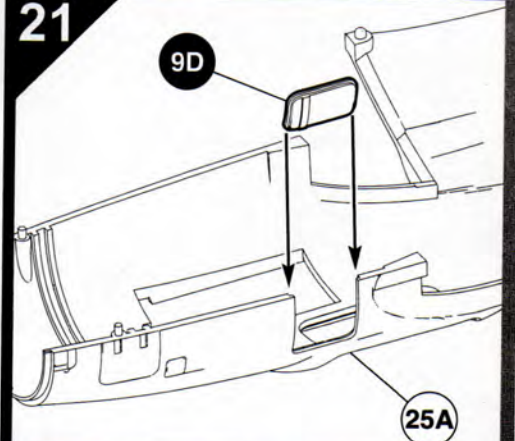

22

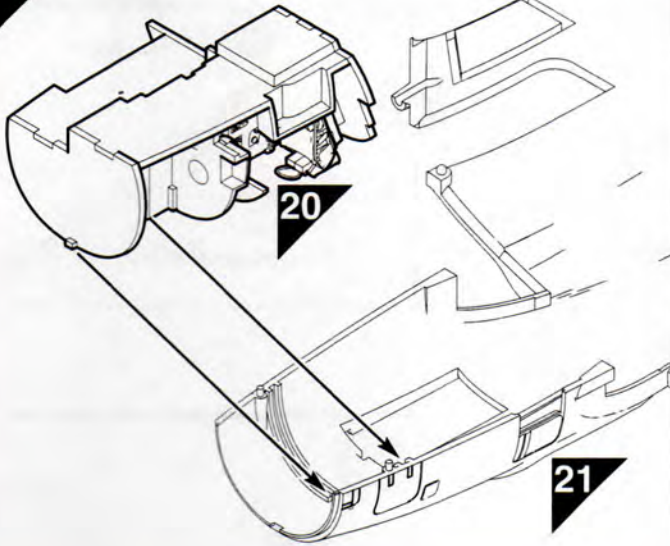

23

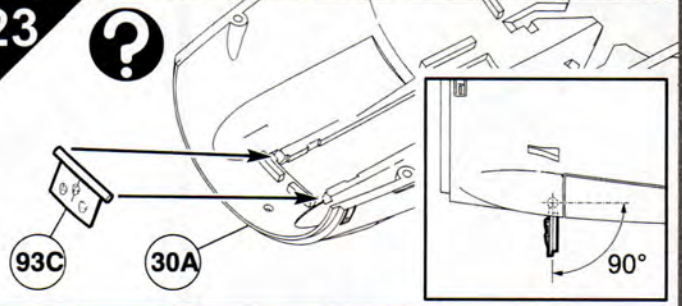

24

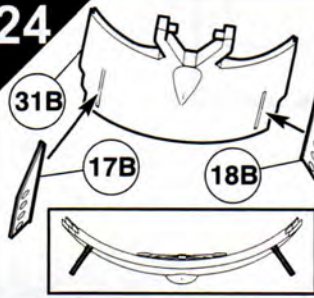

25

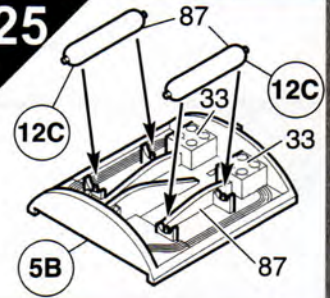

26

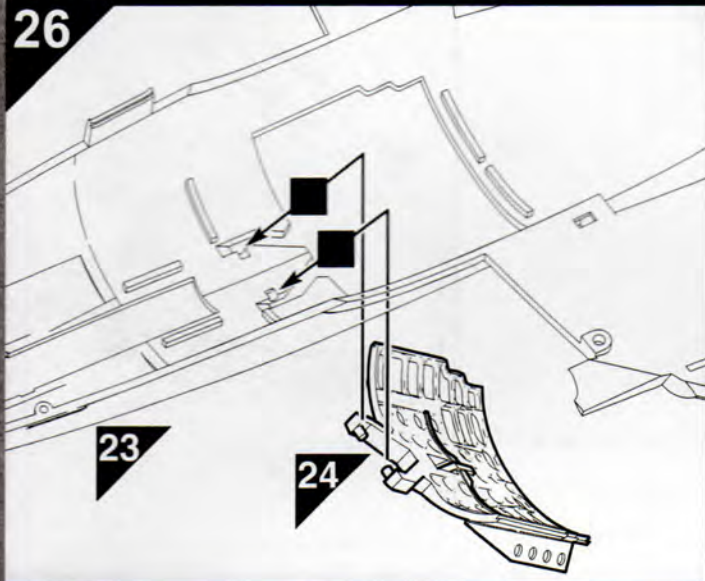

27

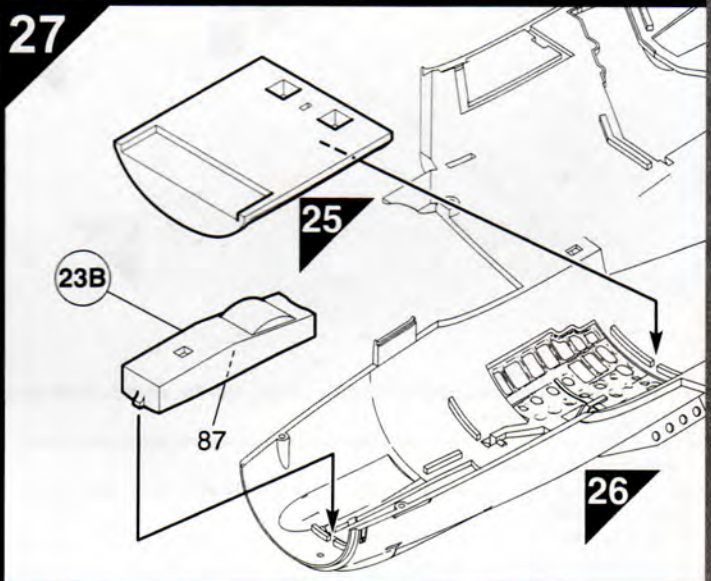

28

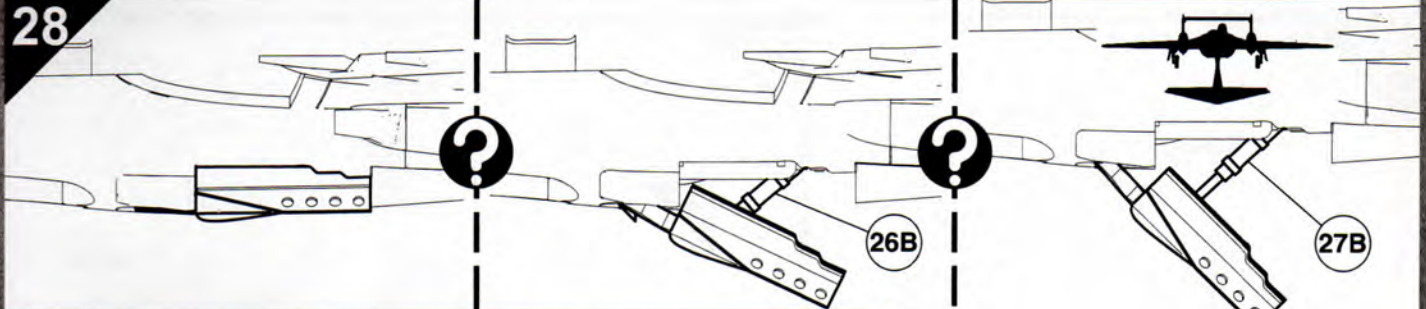

Please note: The model cannot rest on it's wheels with the airbrake in the fully open position.
 Remarque : La maquette n'est pas capable de reposer sur ses roues quand l'aérofrein est ouvert à fond.
 Zur Beachtung: Das Modell kann nicht auf seinen Rädern ruhen, wenn die Druckluftbremse völlig geöffnet ist.
 Nota: Este modelo no puede mantenerse sobre las ruedas si el freno neumático en la posición totalmente abierta.
 Obs! Modellen kan inte vila på hjulen när luftbromsen är i det helt öppna läget.

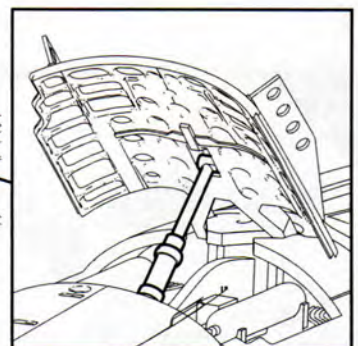
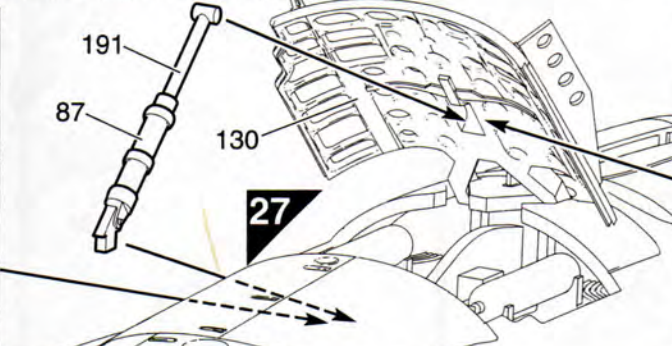
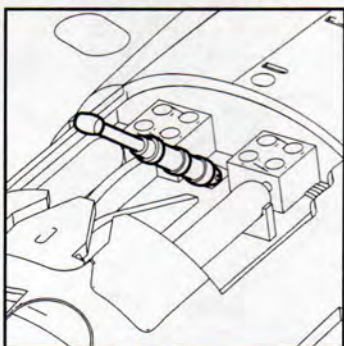

29

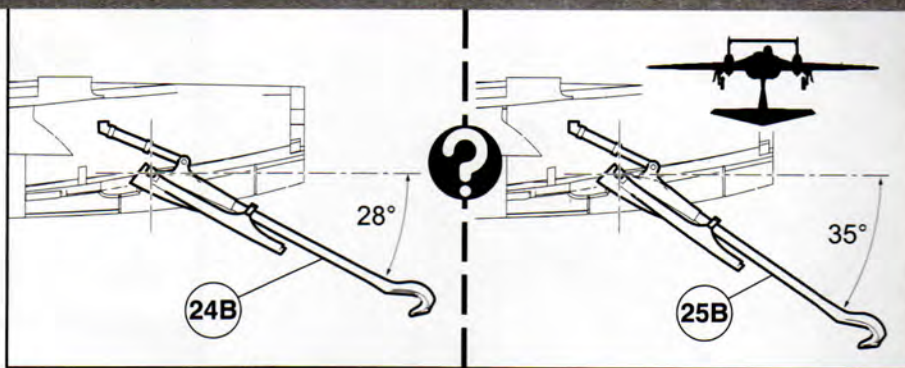
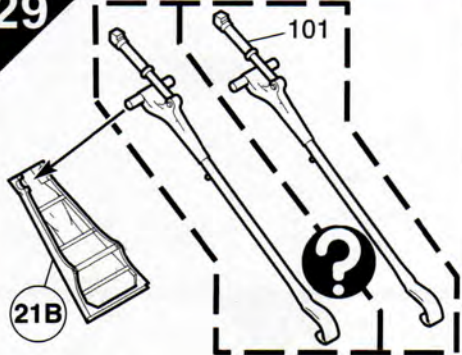

30

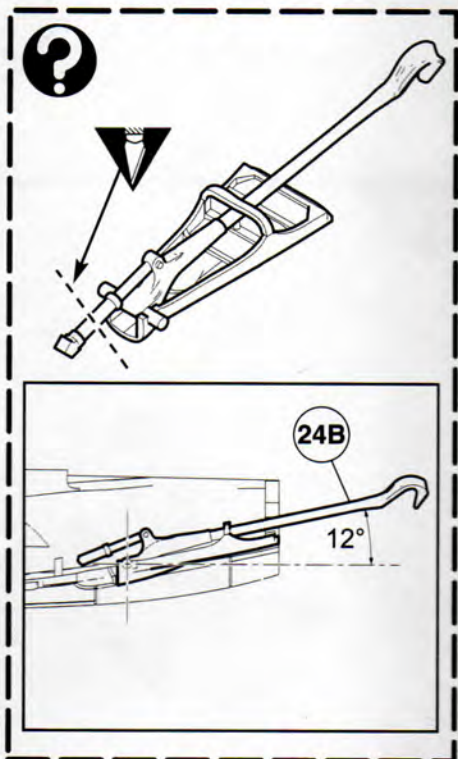
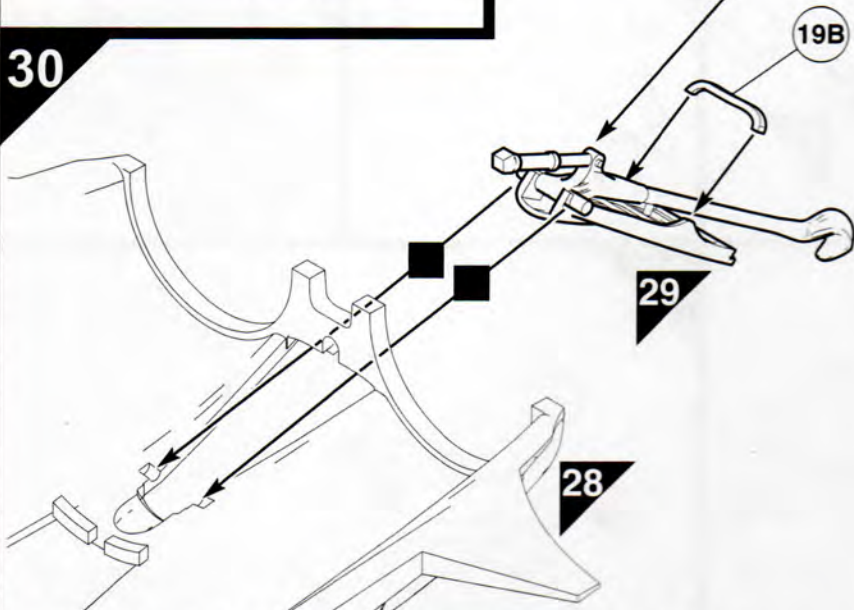

Please note: The model cannot rest on its wheels with the arrester hook (part 25B) in the fully down position.

Remarque : La maquette n'est pas capable de reposer sur ses roues quand la crose d'arrêt (pièce 25B) est descendue à fond.

Zur Beachtung: Das Modell kann nicht auf seinen Rädern ruhen, wenn sich der Fanghaken (Teil 25B) ganz unten befindet.

Nota: Este modelo no puede mantenerse sobre las ruedas con el gancho del cable de frenado (pieza 25B) en la posición totalmente bajada.

Obs! Modellen kan inte vila på hjulen när bromslinan (del 25B) är i det nedre läget.

31

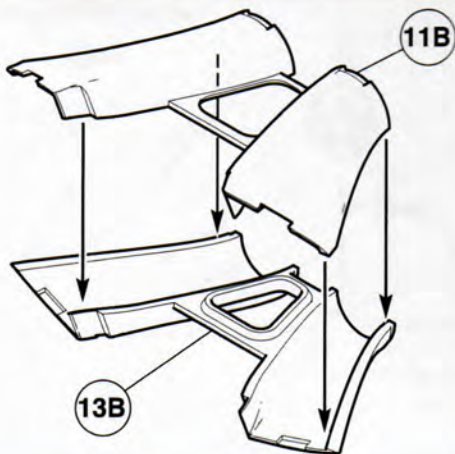

32

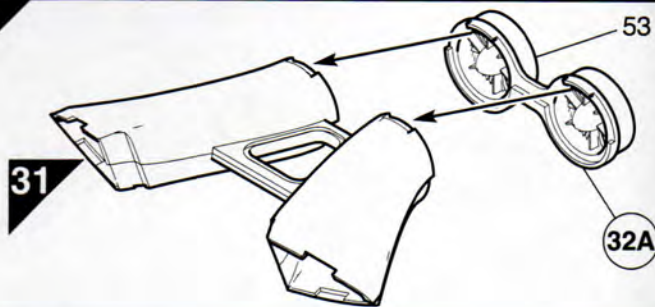

33

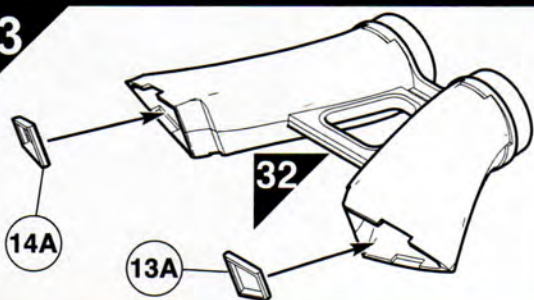

34

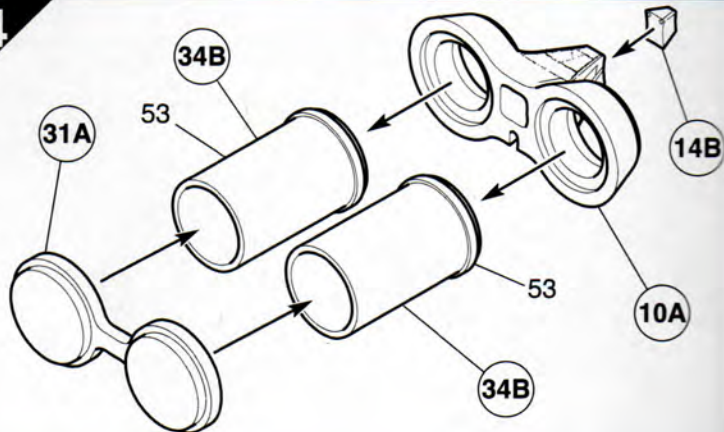

35

130

33

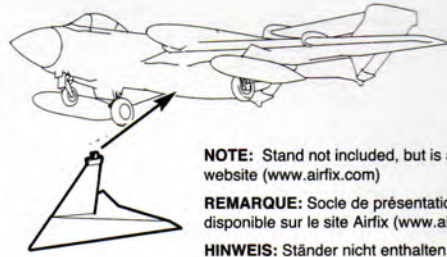
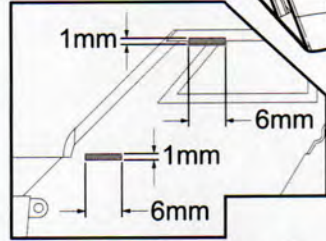

NOTE: Stand not included, but is available via the Airfix website (www.airfix.com)

REMARQUE: Socle de présentation non fourni mais disponible sur le site Airfix (www.airfix.com)

HINWEIS: Ständer nicht enthalten, ist jedoch über die Website von Airfix (www.airfix.com) erhältlich

NOTA: No se incluye soporte, que está disponible en el sitio web de Airfix (www.airfix.com)

OBS! Stativ ingår inte, men finns tillgänglig på Airfix webbplats (www.airfix.com)

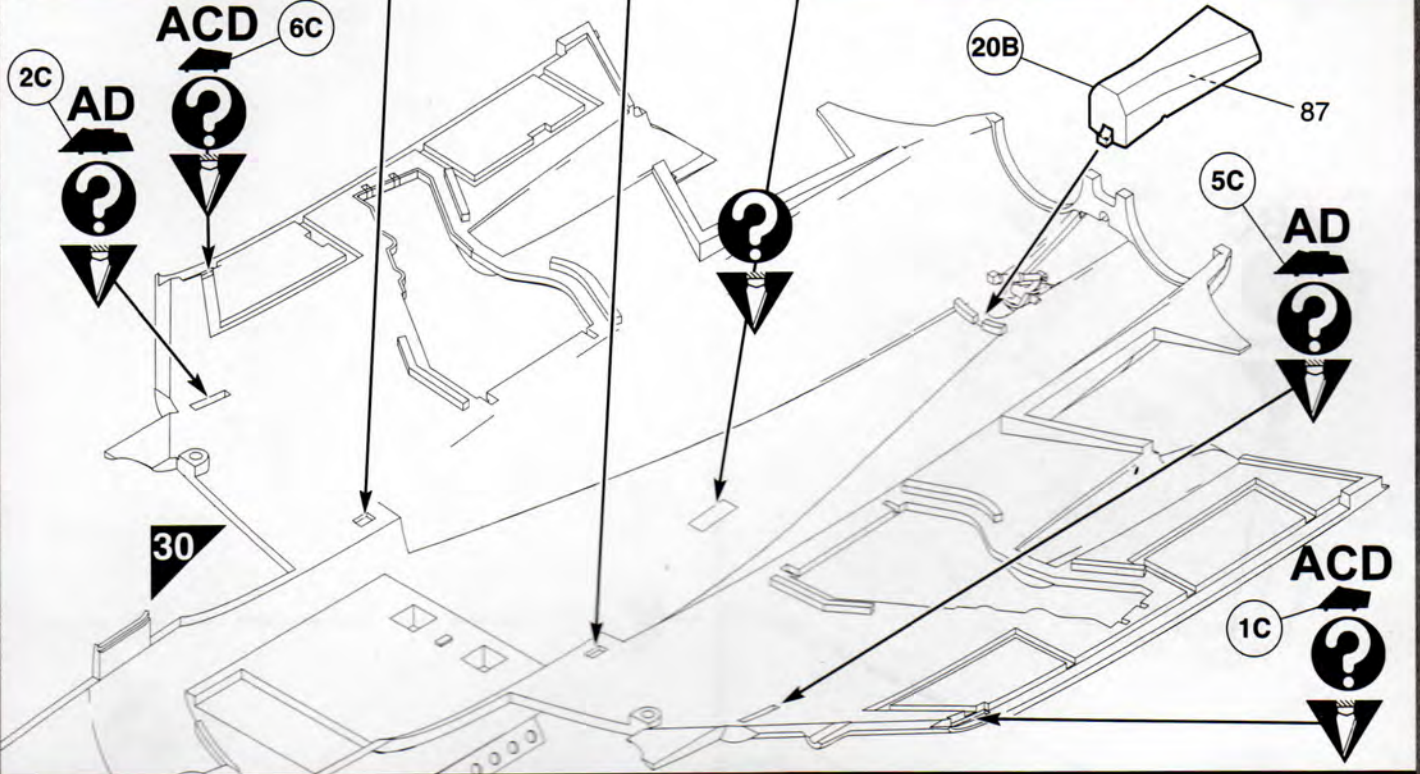

36

34

35

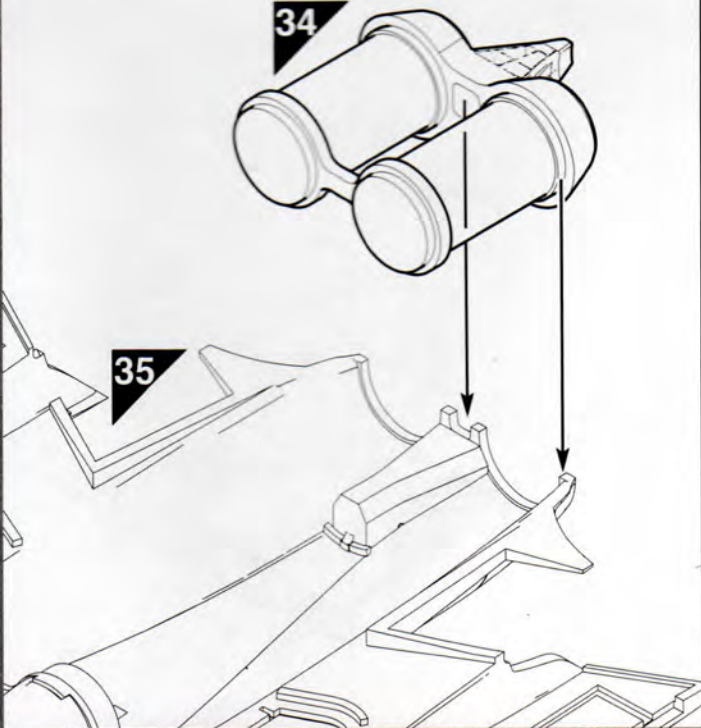

37

8B

7B

36

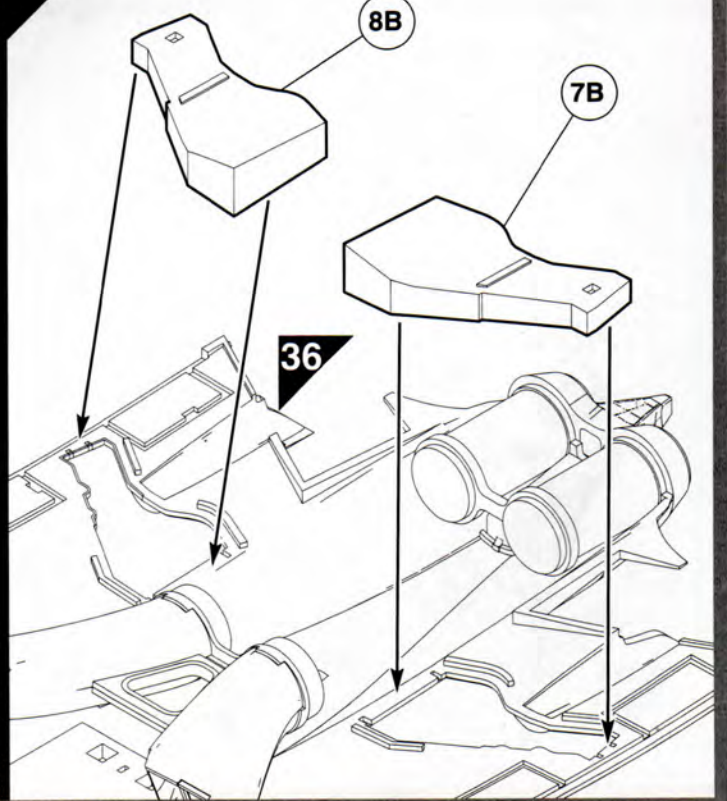

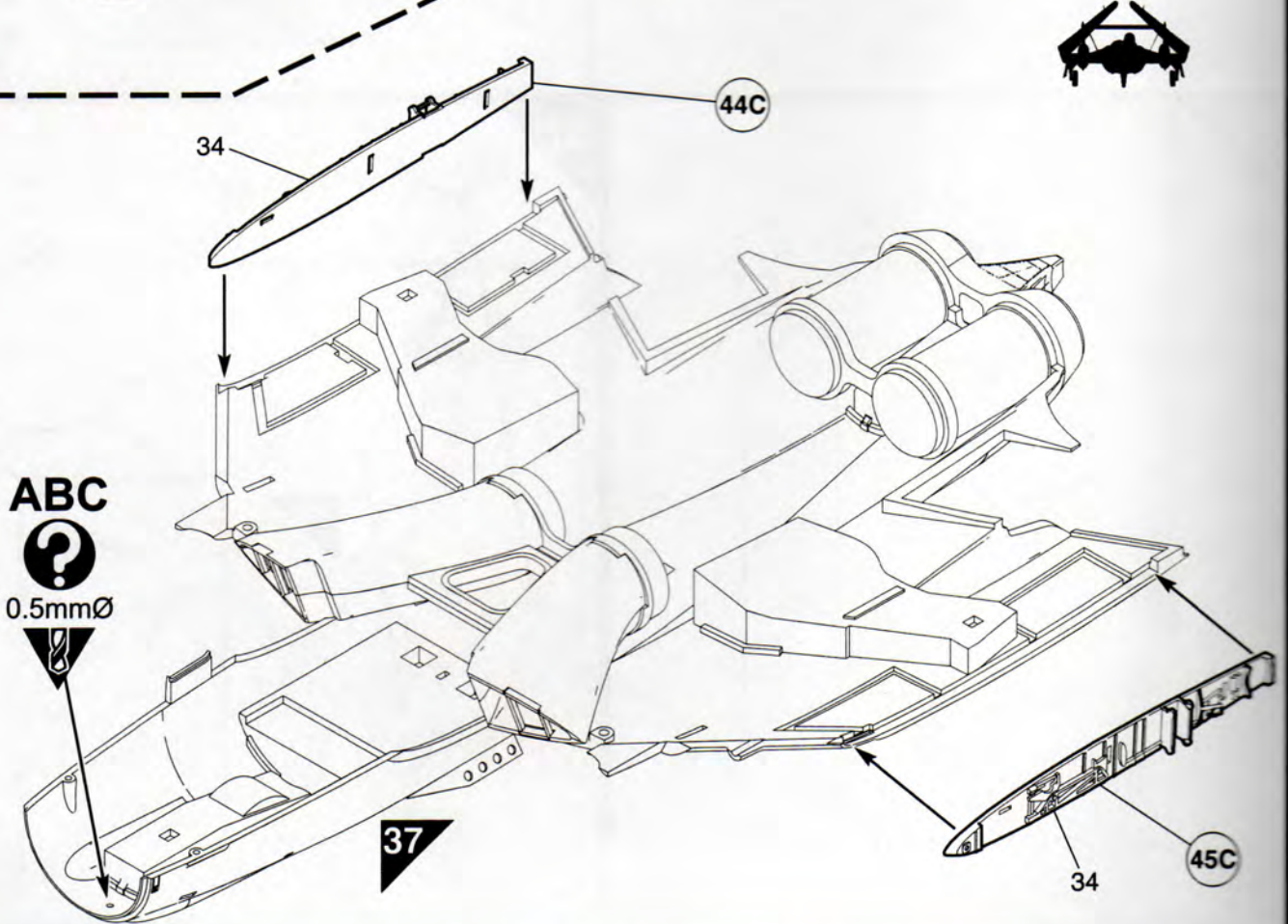
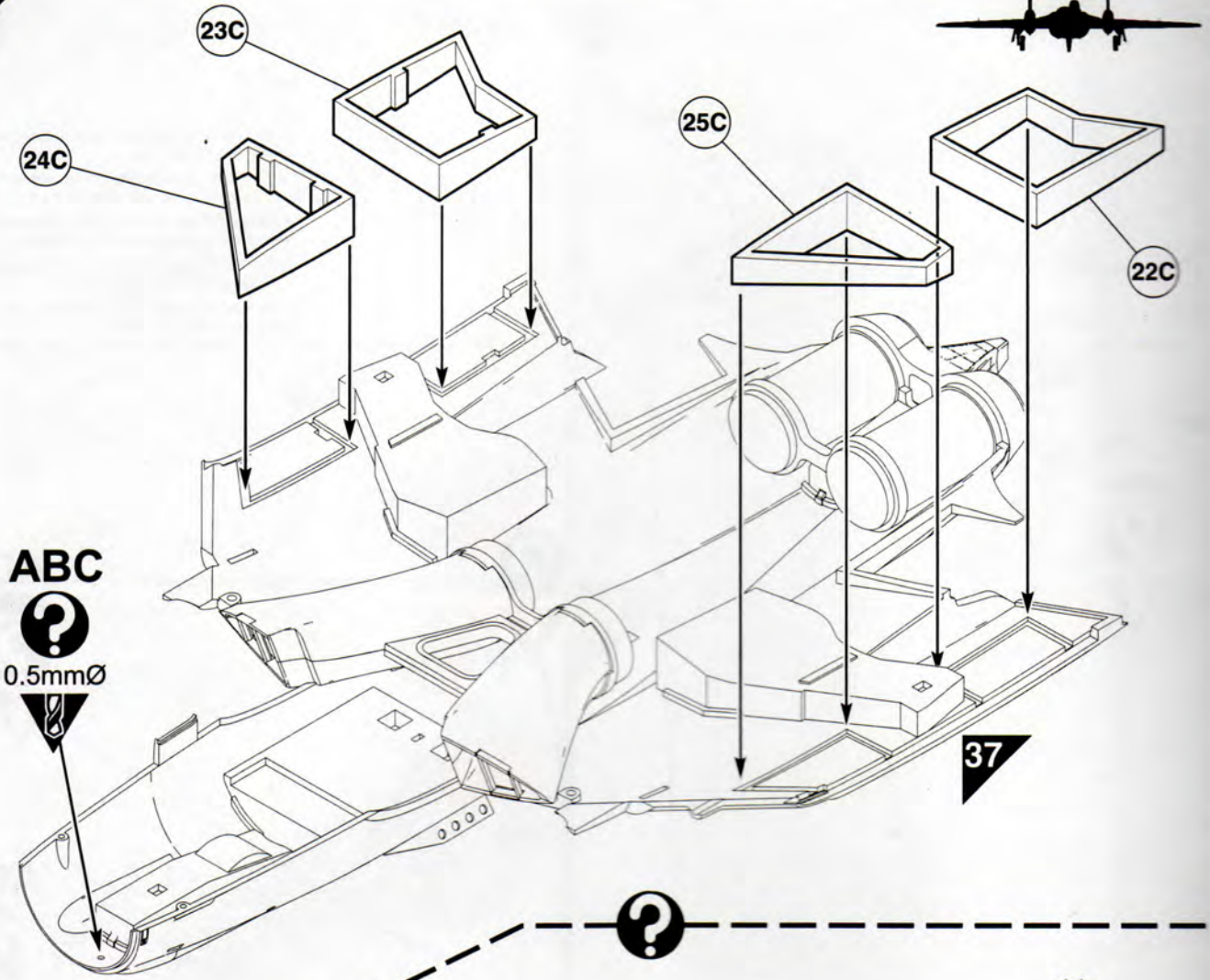

39

22

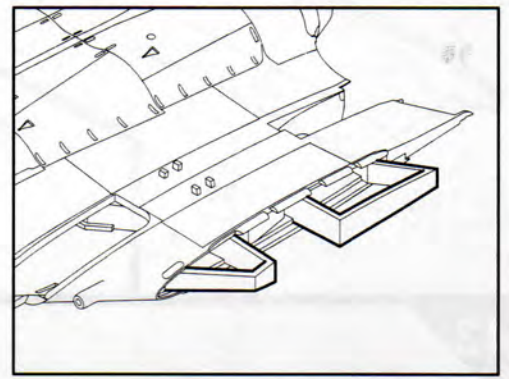
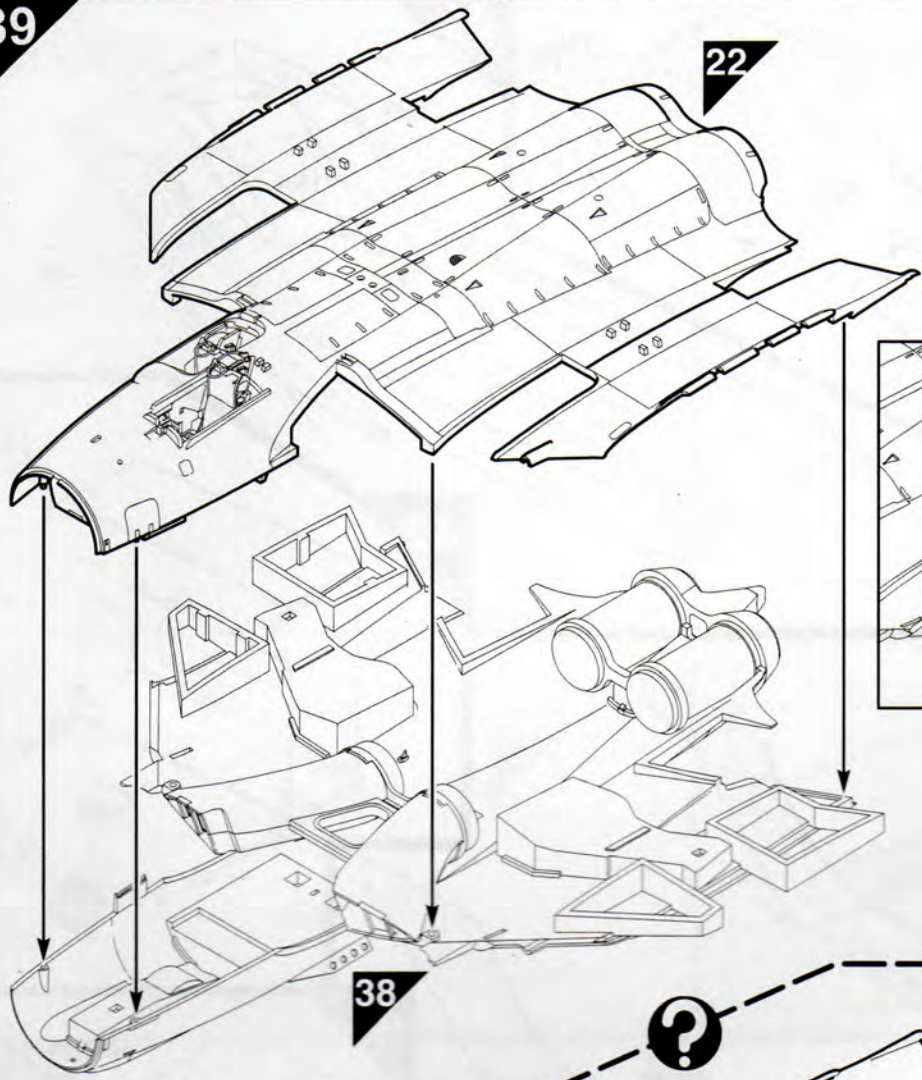

38

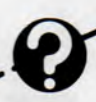

22

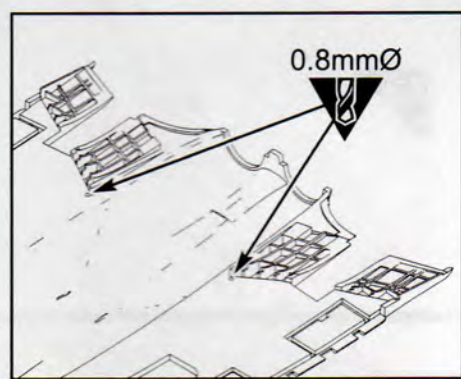
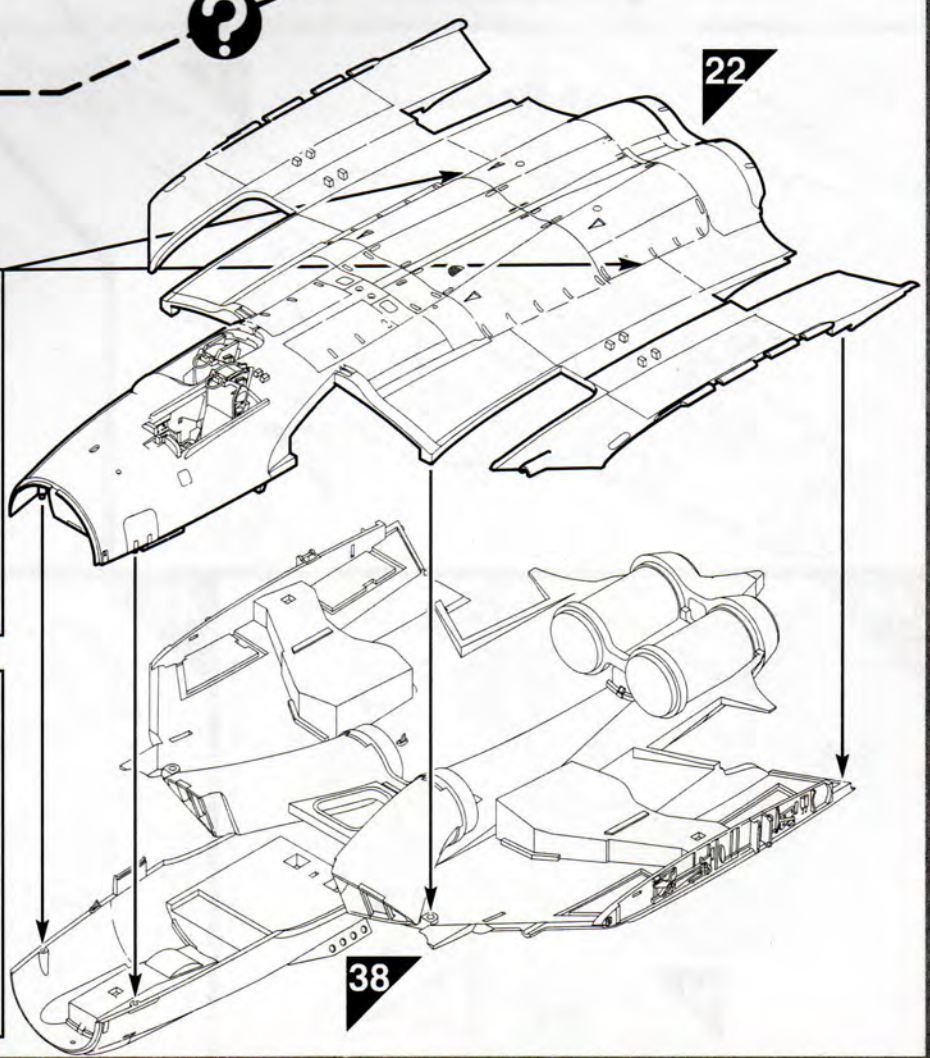

0.8mmØ

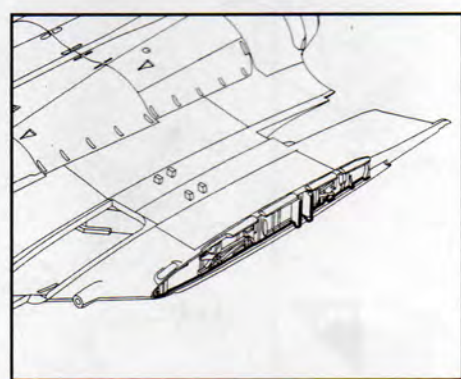

38

40

41

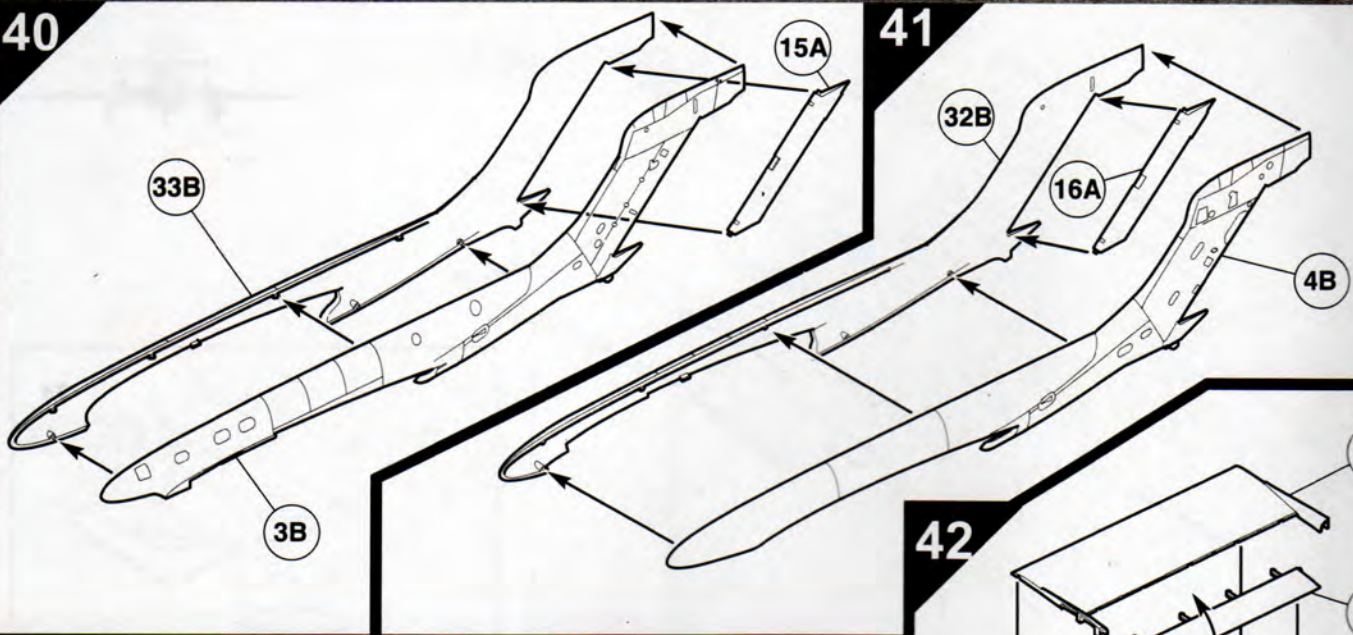

43

42

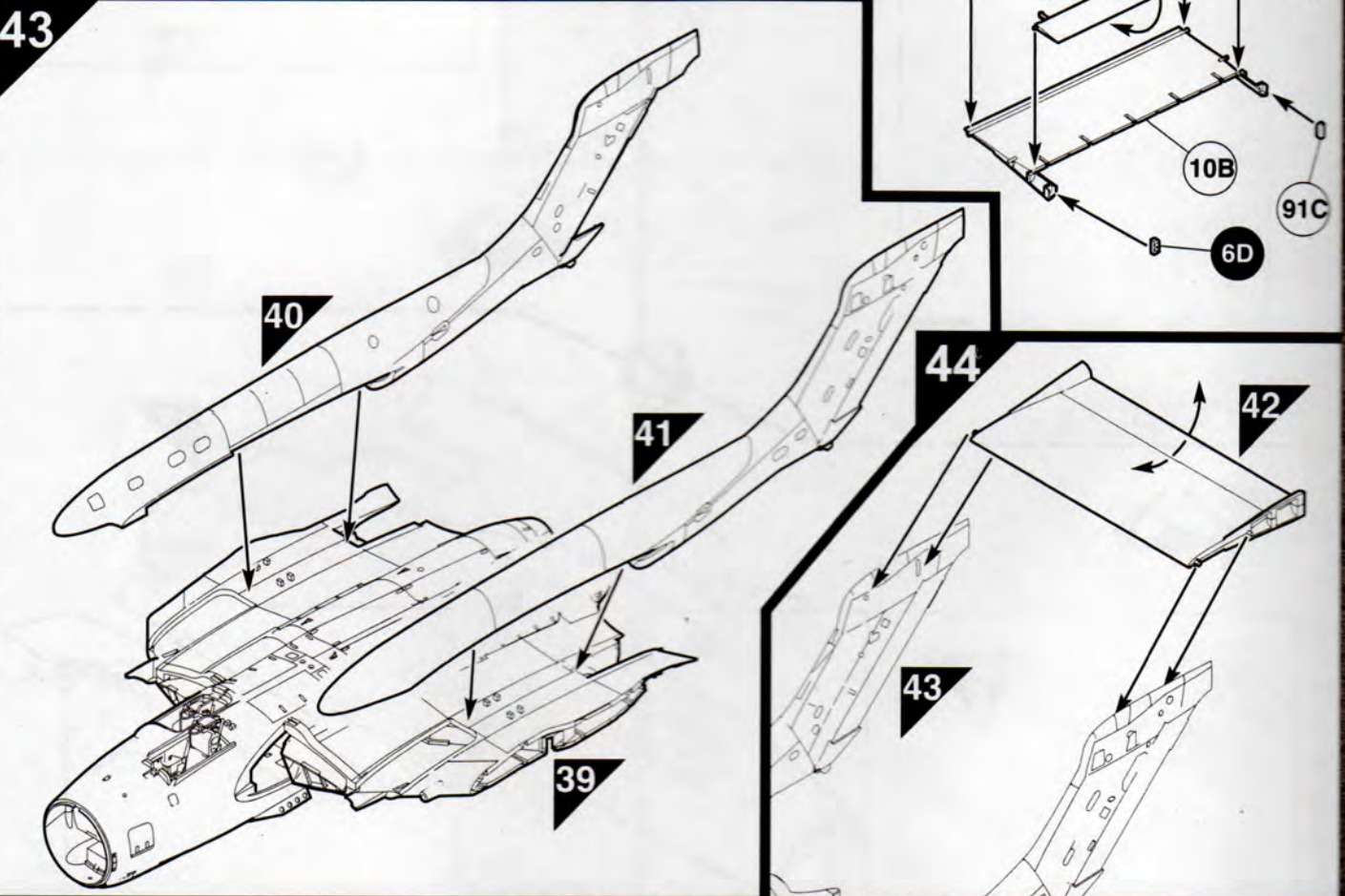

45

46

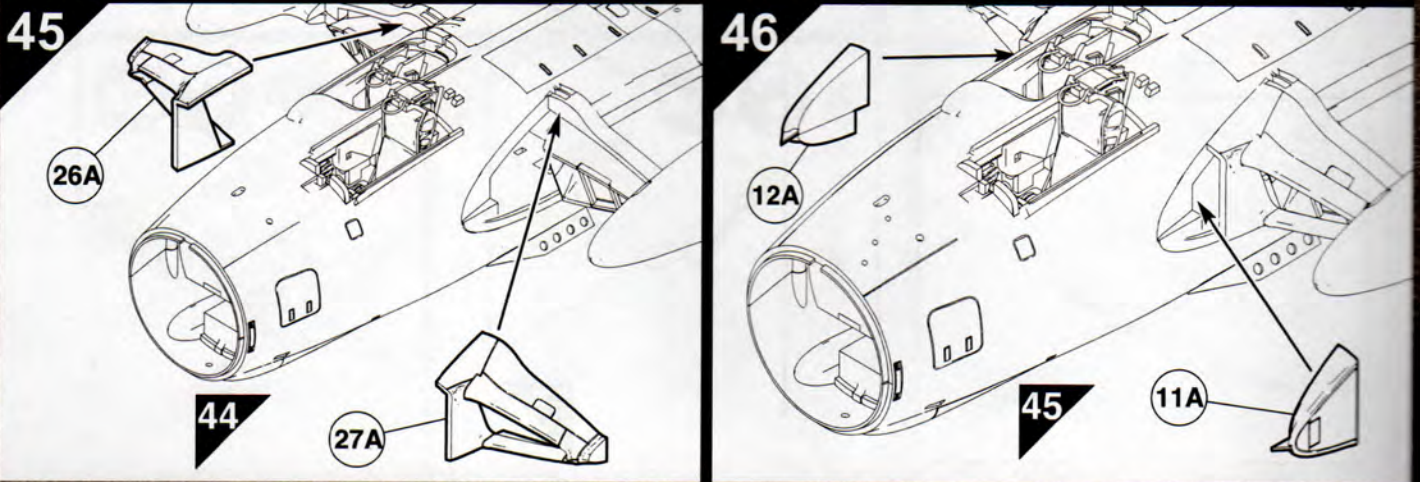

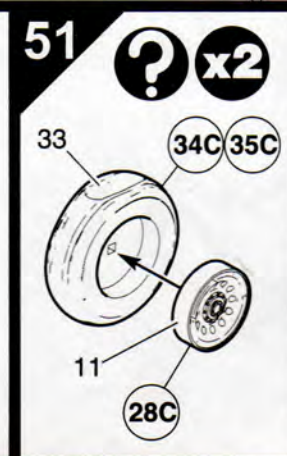
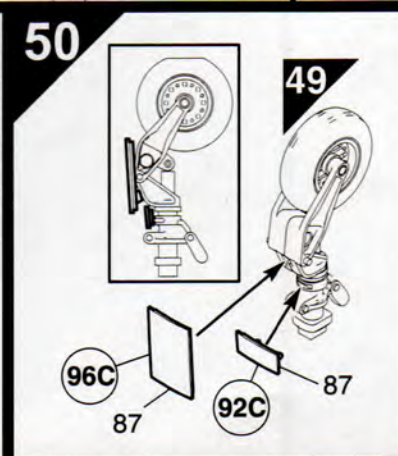
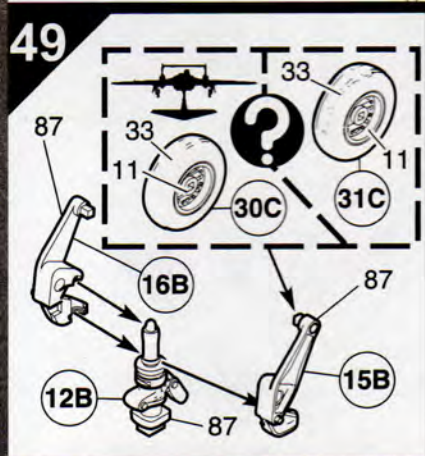
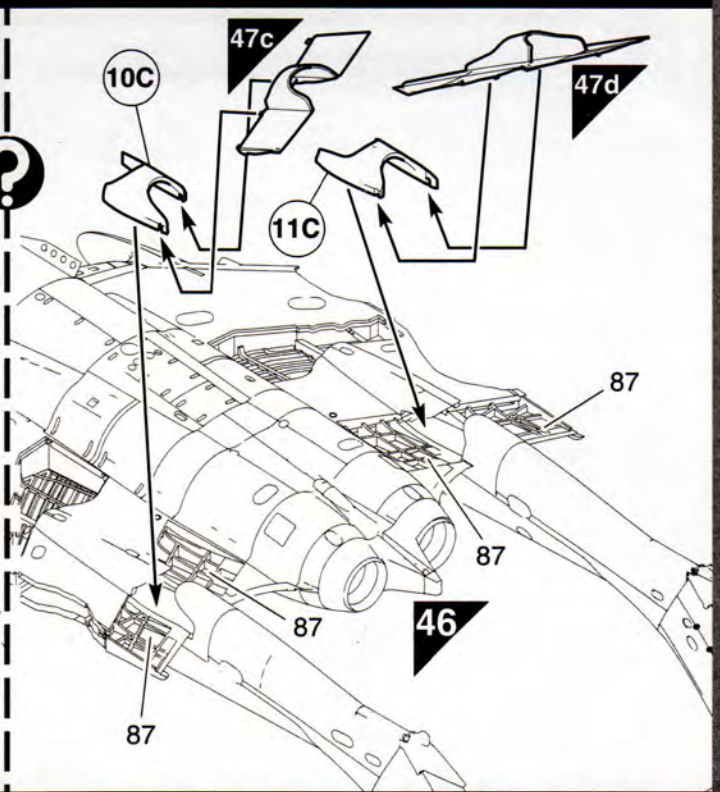
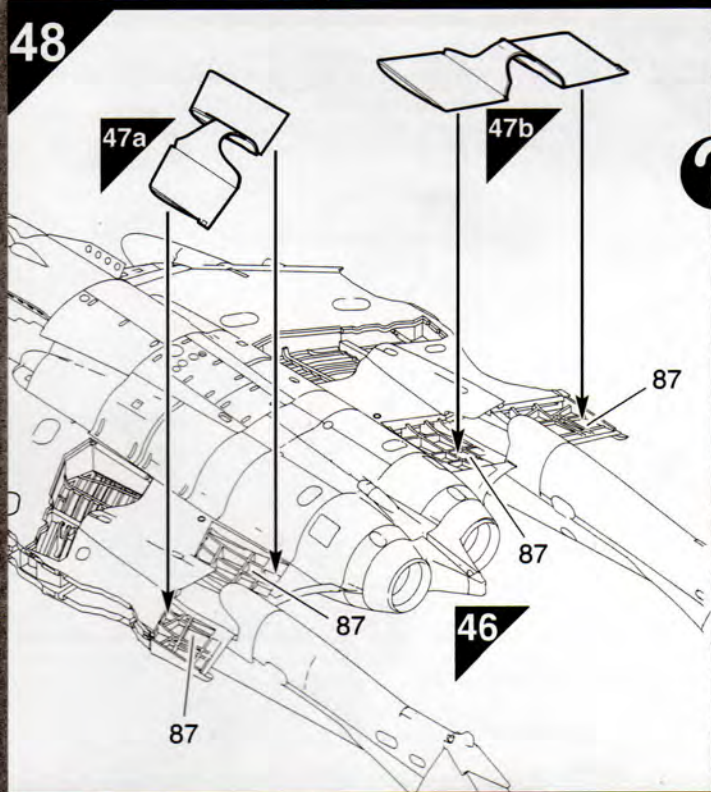
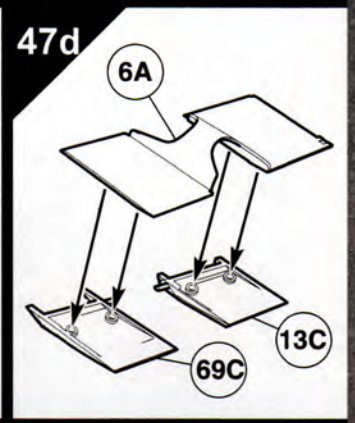
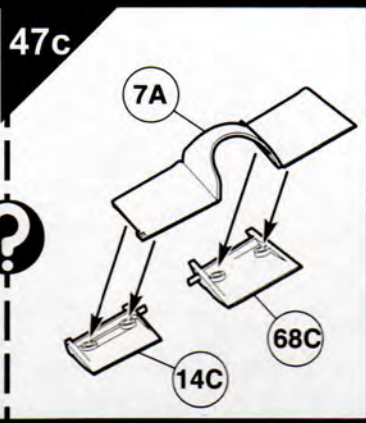
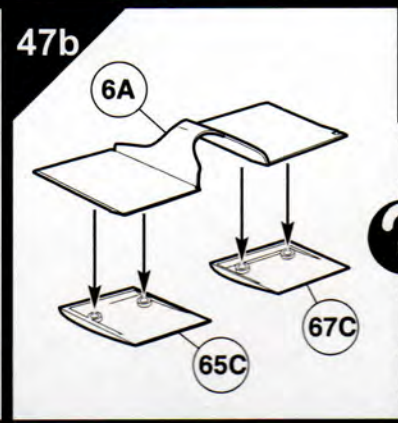
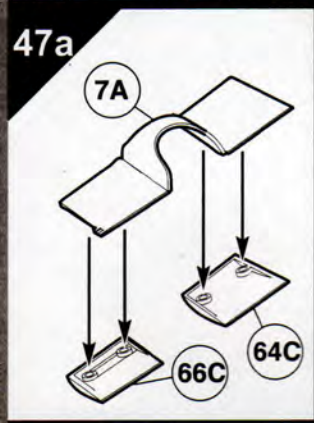
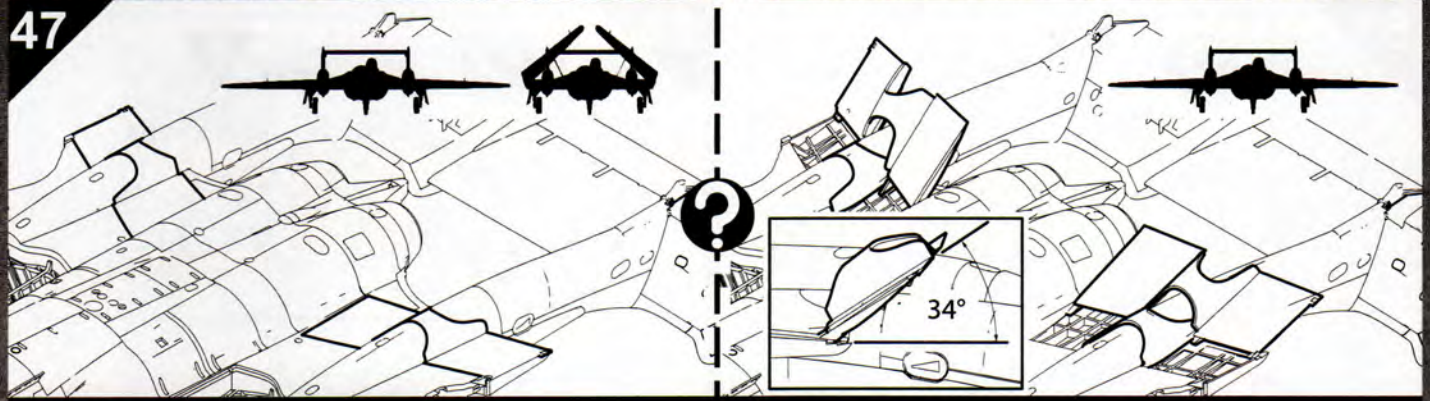

53

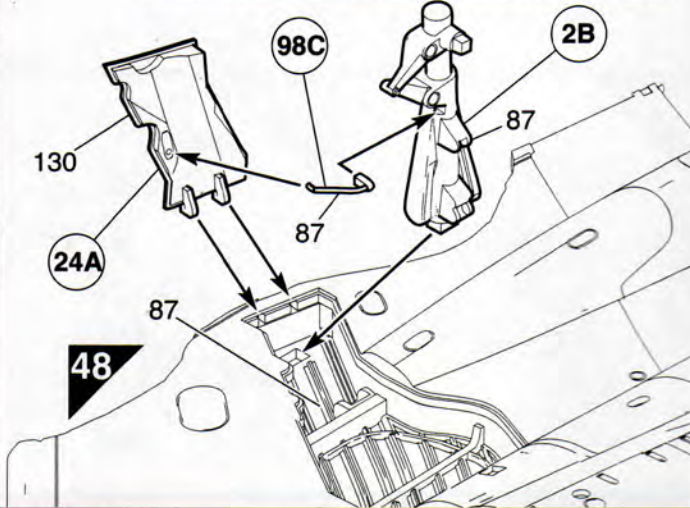
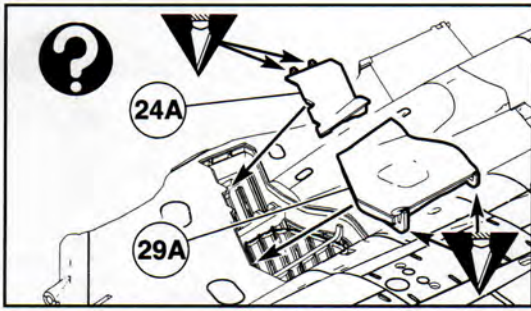

54

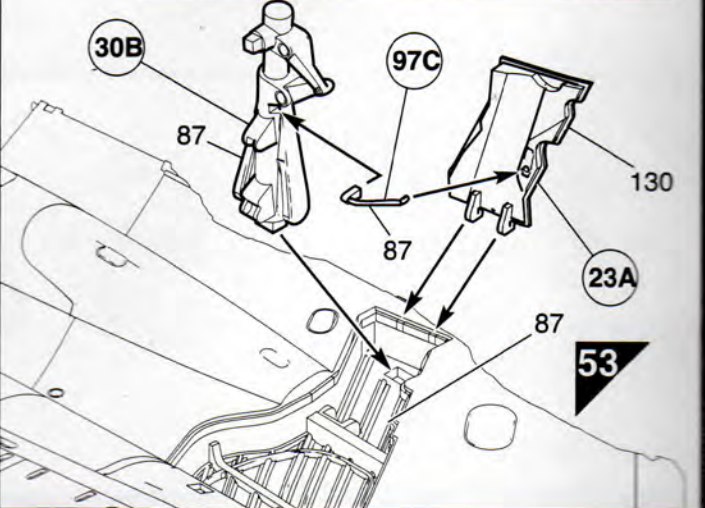
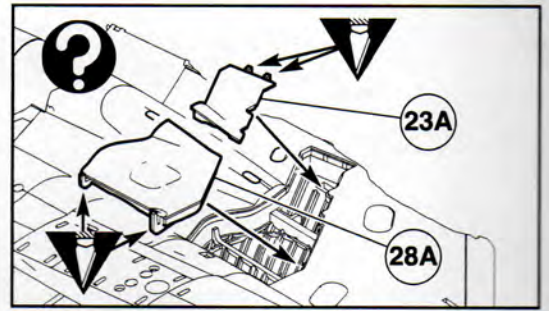

55

Please note: On the real aircraft the inner undercarriage doors (parts 28A & 29A) return to the closed position after the wheels are lowered for landing. The doors can be opened for maintenance when the aircraft is on the ground.

Remarque : Les portes intérieures du train d'atterrissage de l'avion réel (pièces 28A & 29A) reprennent leur position fermée après la descente des roues pour l'atterrissage. Les portes peuvent être ouvertes pour l'entretien lorsque l'appareil a atterri.

Zur Beachtung: Am wirklichen Flugzeug kehren die inneren Fahrwerksklappen (Teil 28A und 29A) nach dem Ausfahren der Räder zur Landung in die geschlossene Stellung zurück. Bei am Boden befindlichem Flugzeug können die Klappen zwecks Wartung geöffnet werden.



56

Nota: En el avión real, las puertas del tren de aterrizaje (piezas 28A y 29A) vuelven a la posición de cerrado después de bajarse las ruedas para el aterrizaje. Cuando el avión está en tierra, las puertas pueden abrirse manualmente para operaciones de mantenimiento.

Obel På det riktiga flygplanet återgår landningsställens inre luckor (del 28A och 29A) till det stängda läget efter att hjulen har fällits ut inför landing. Luckorna kan öppnas för underhåll när flygplanet står på marken.

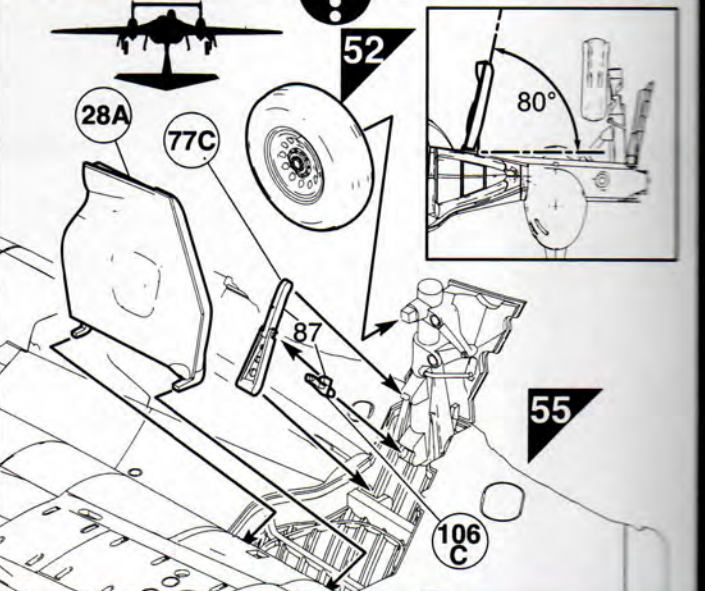
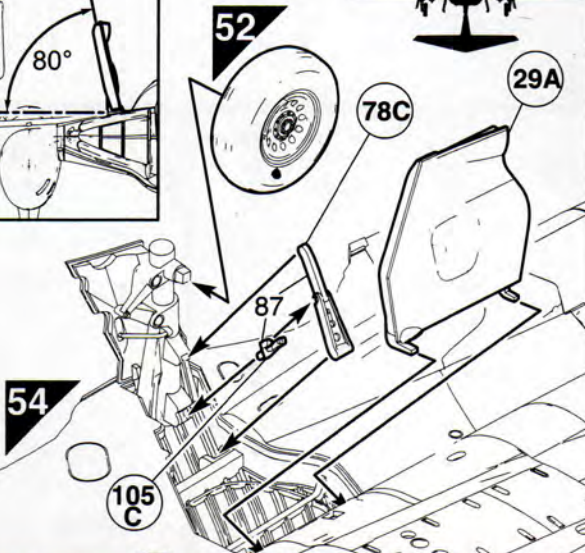
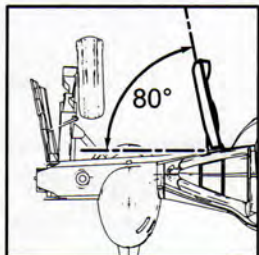
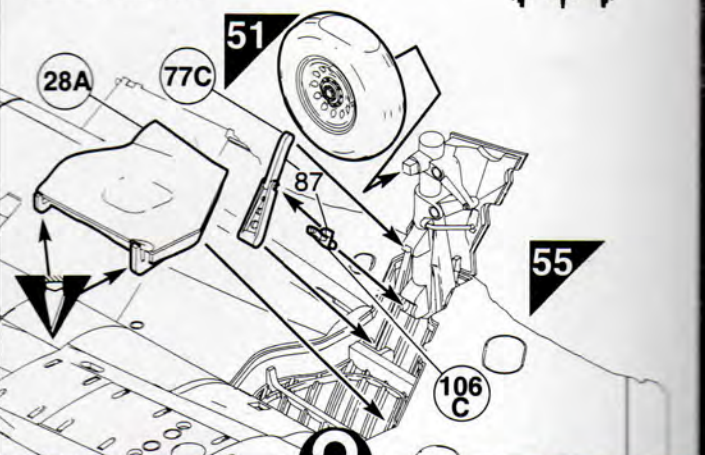
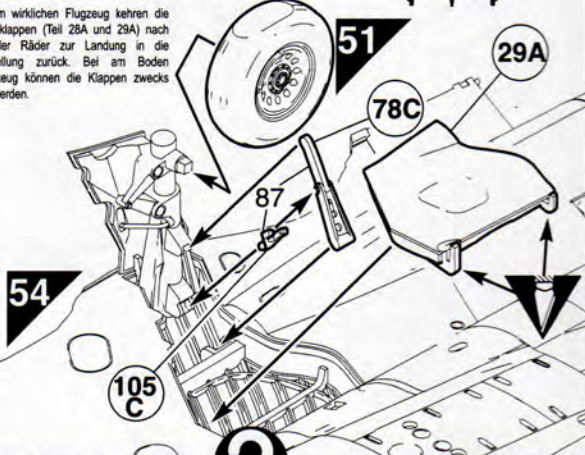

57

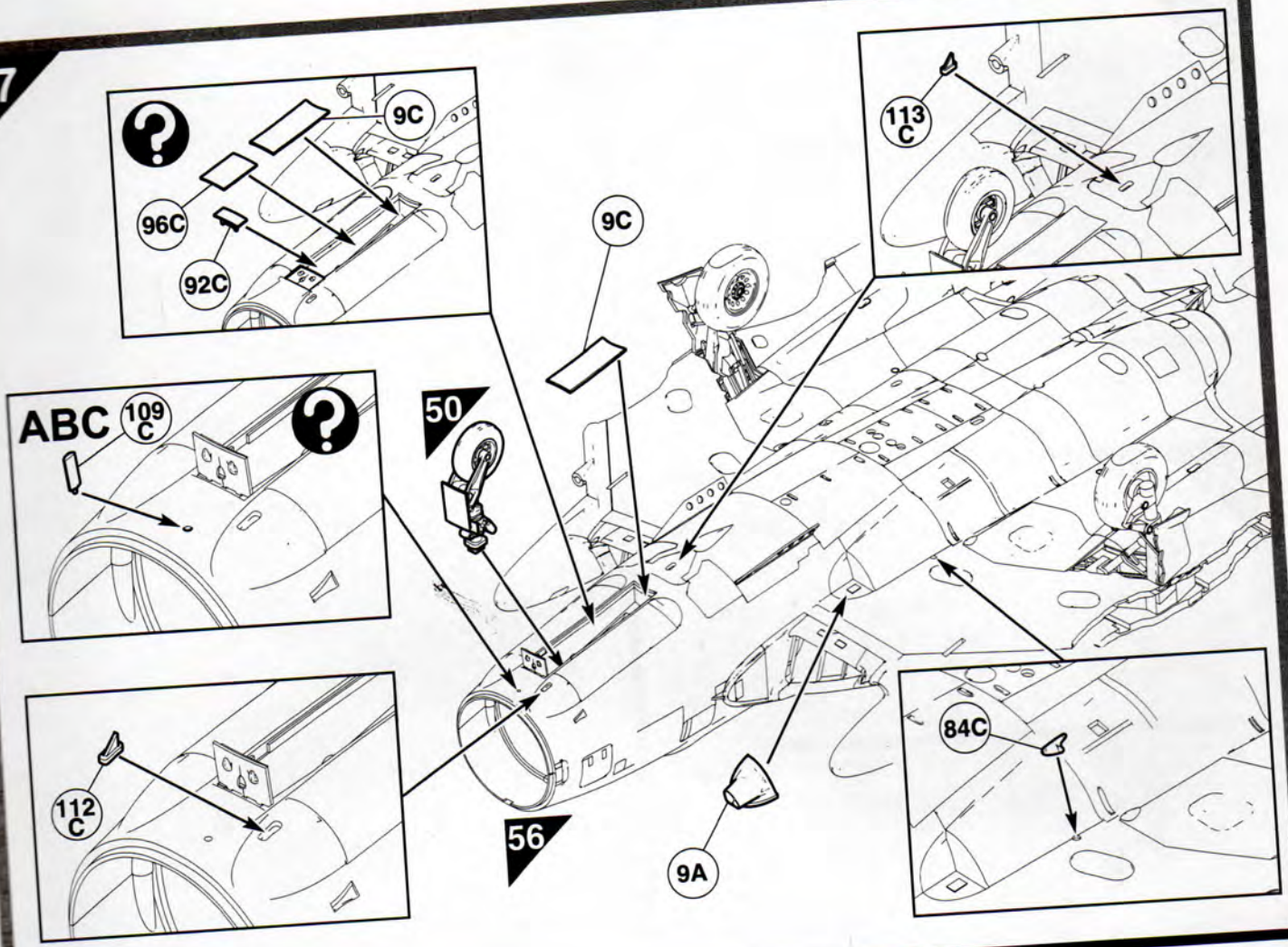

58

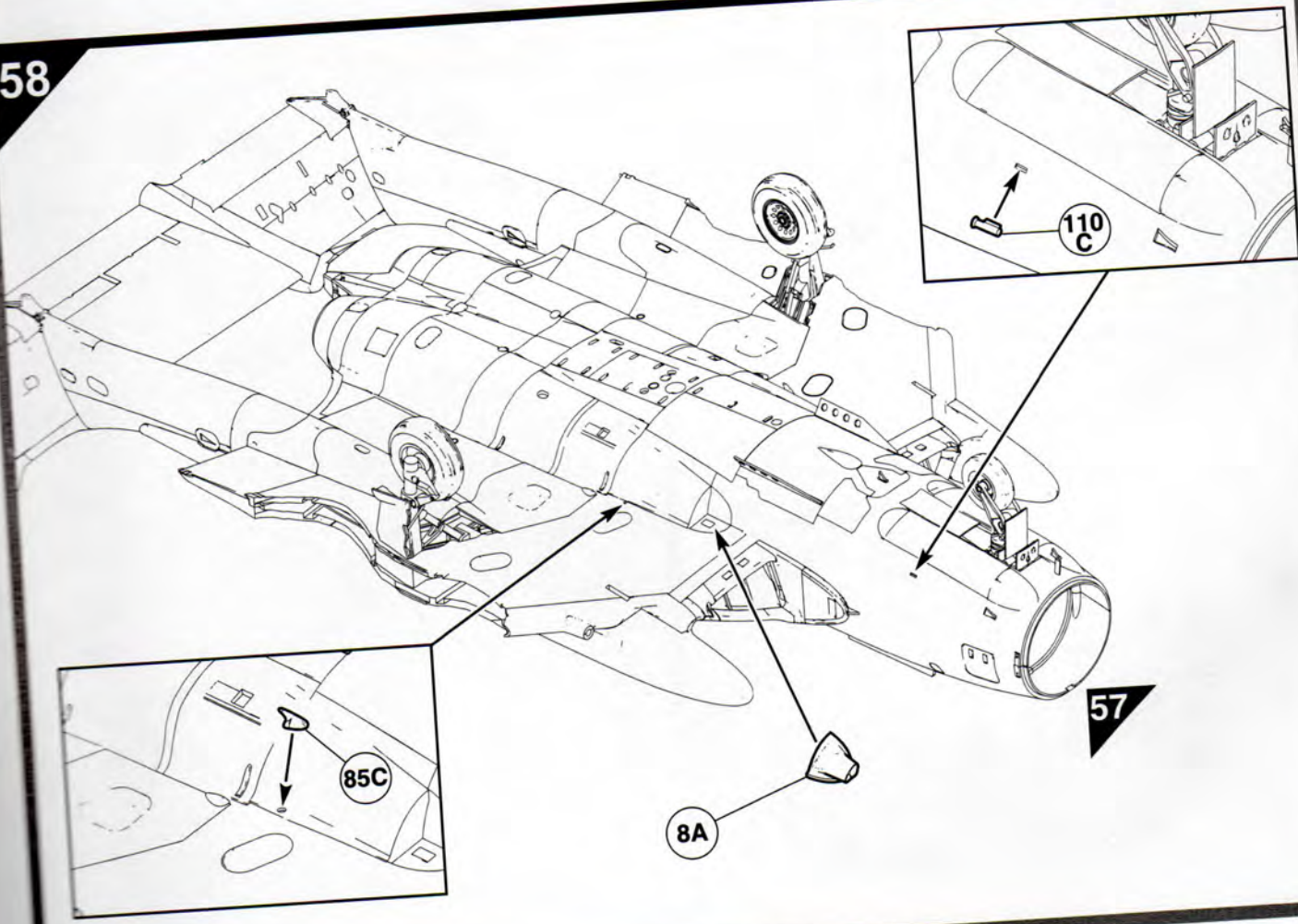

59

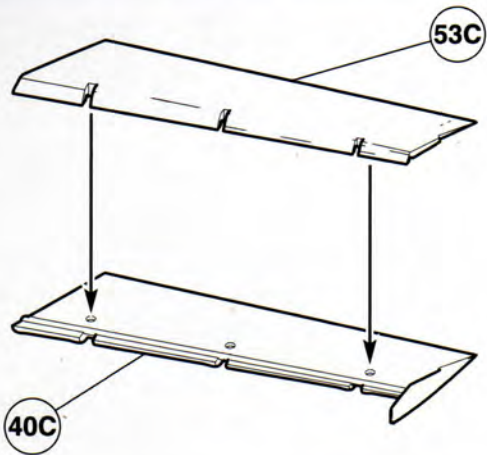

60

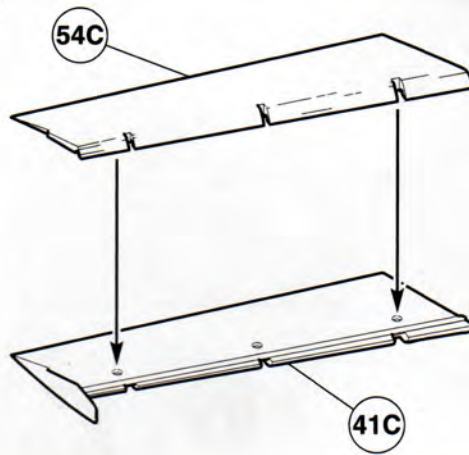

61

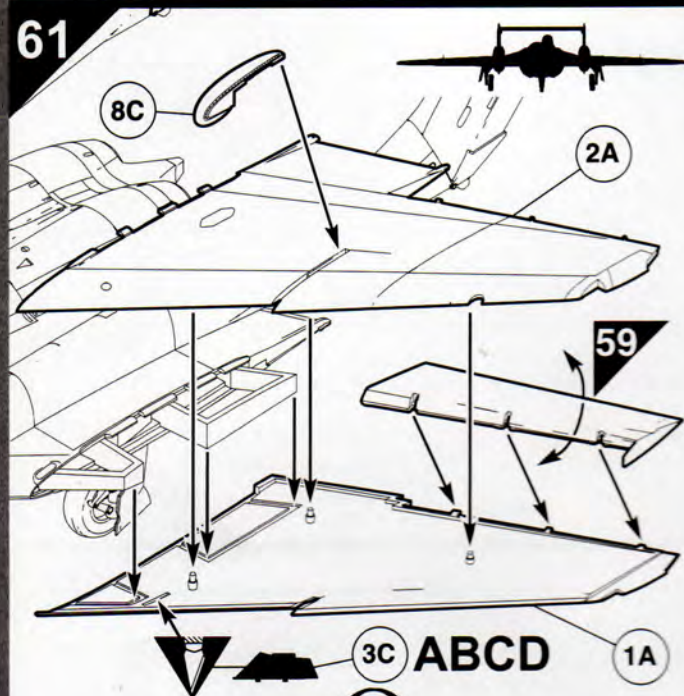

62

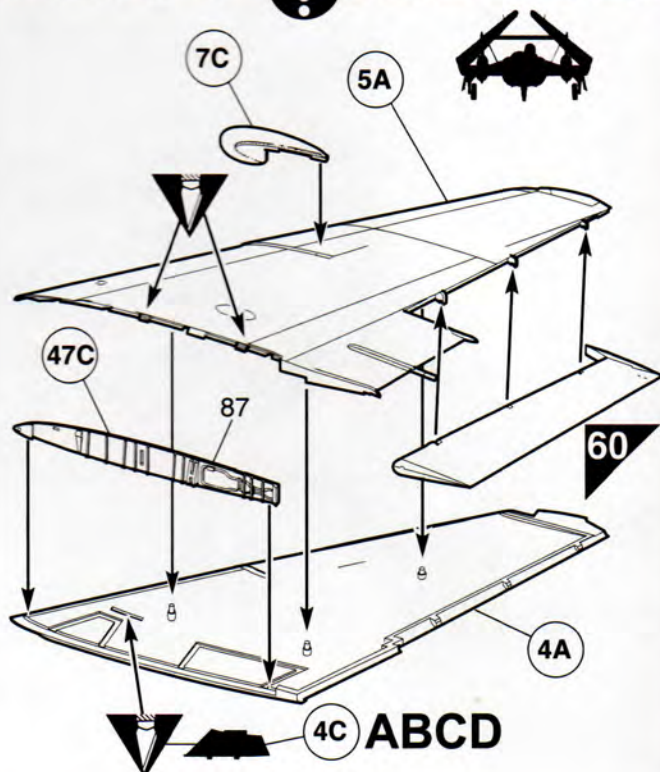
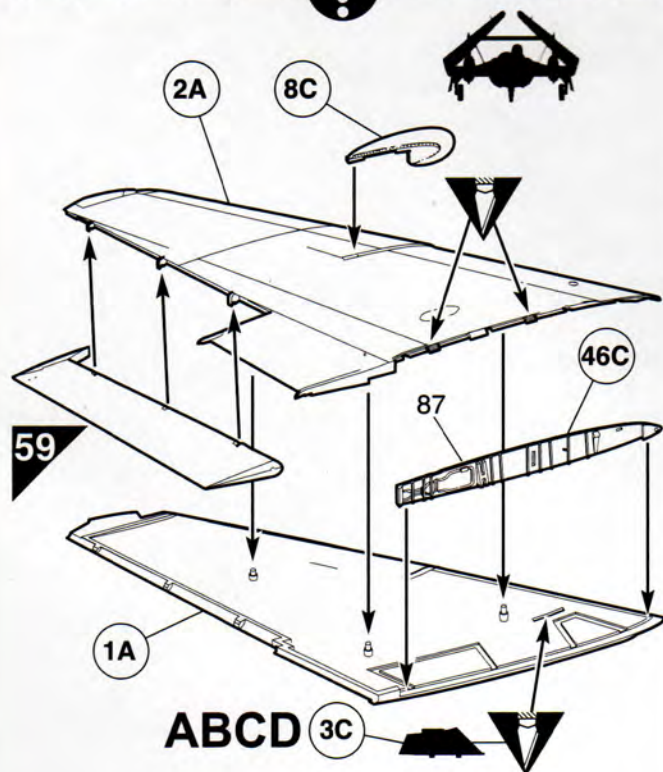
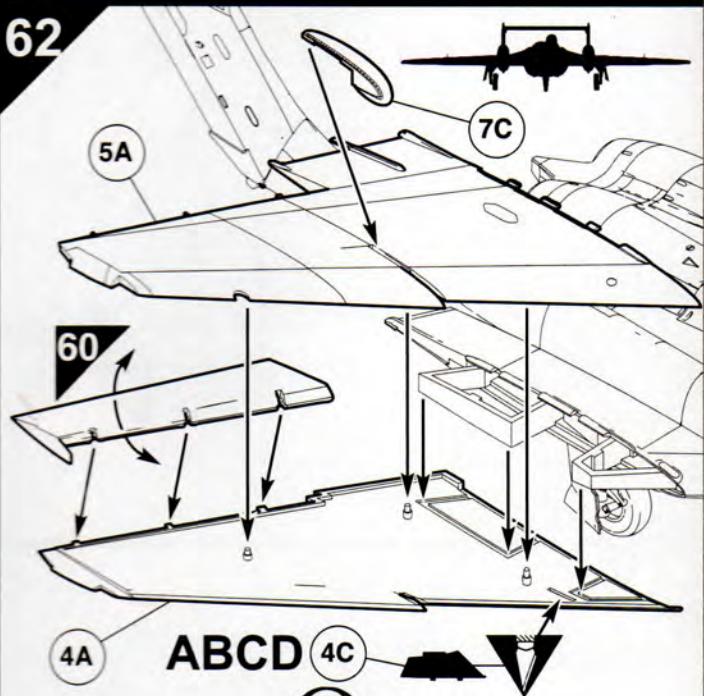

63

16C

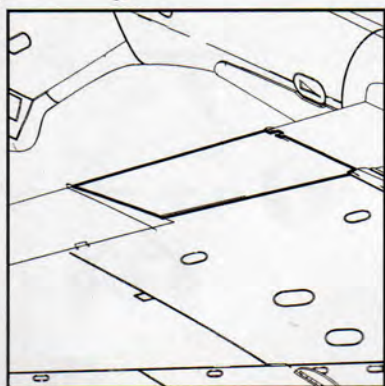
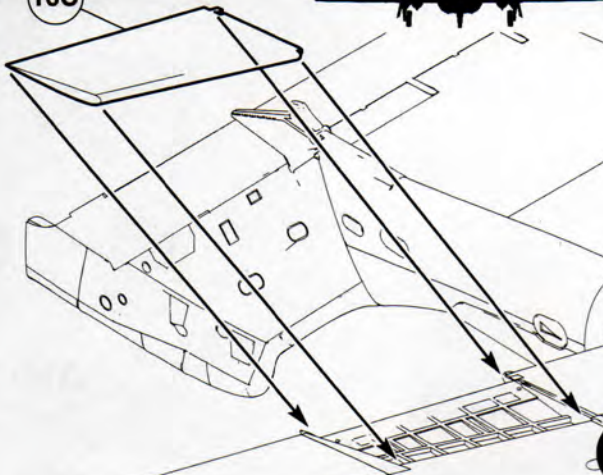

62

17C

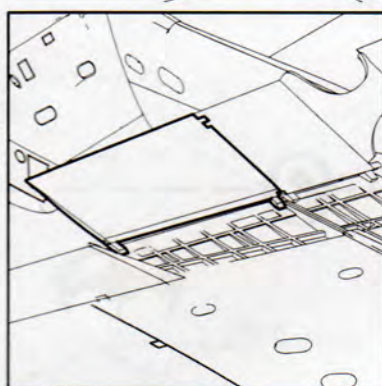
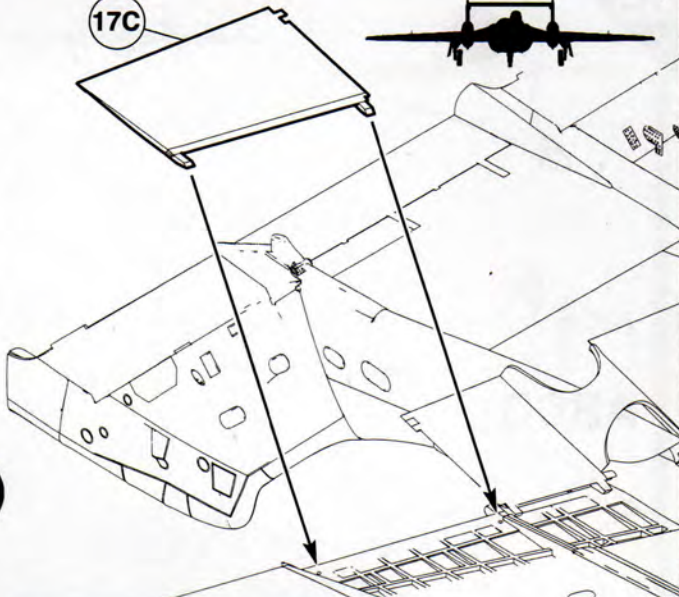

62

64

15C

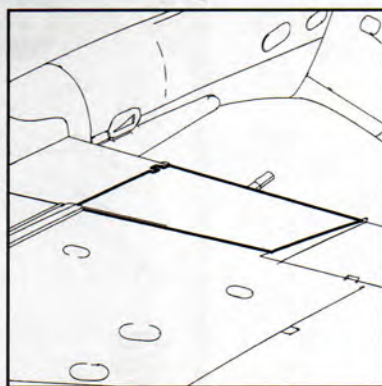
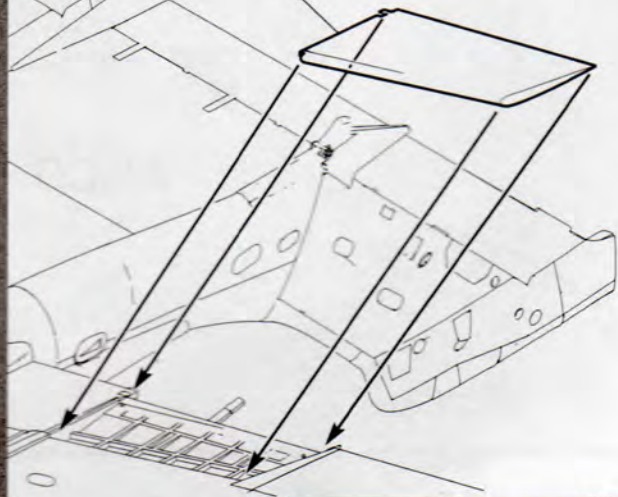

63

18C

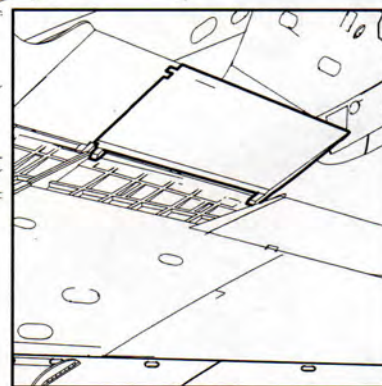
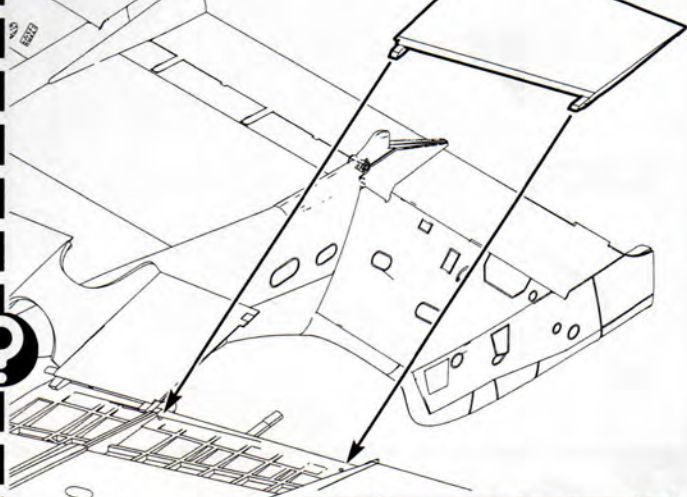

63

65

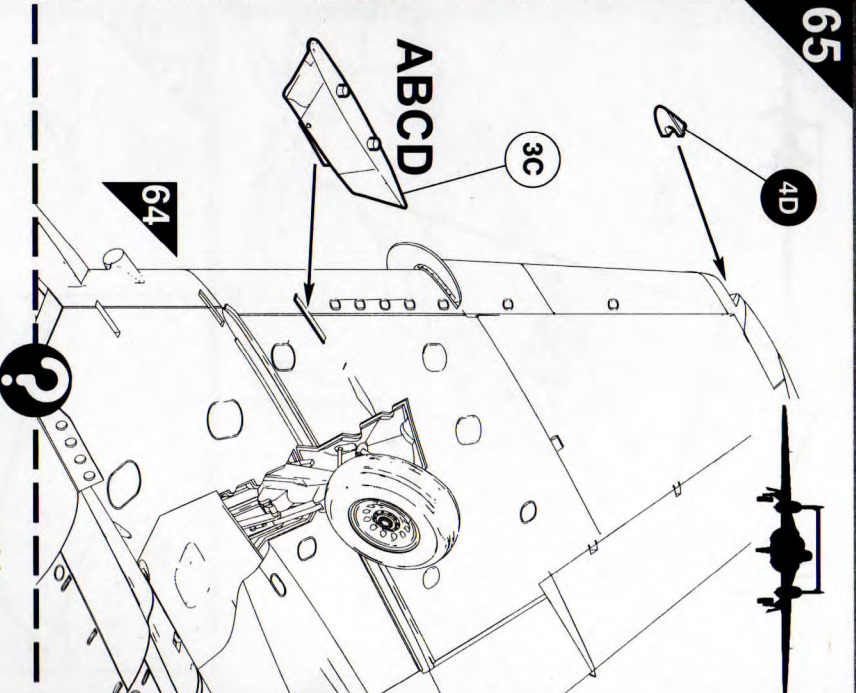

66

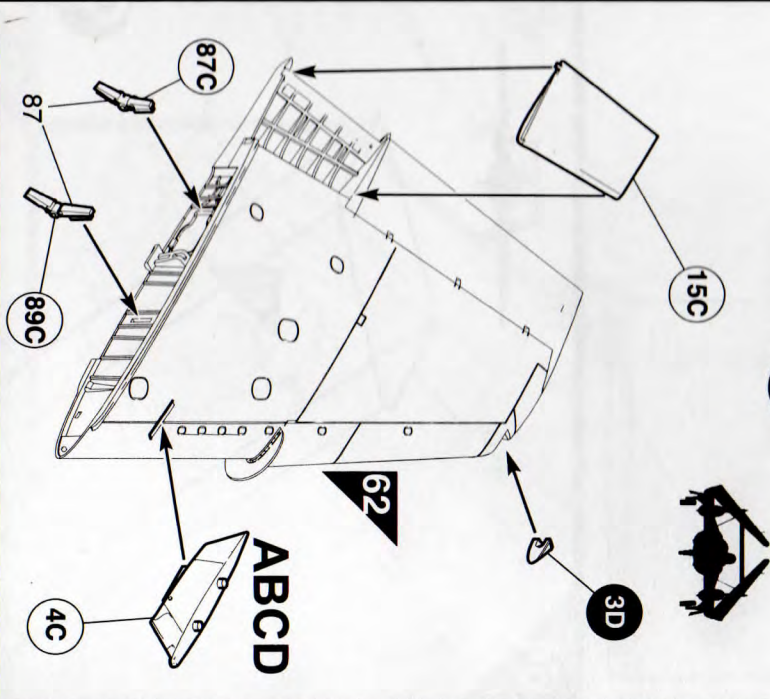
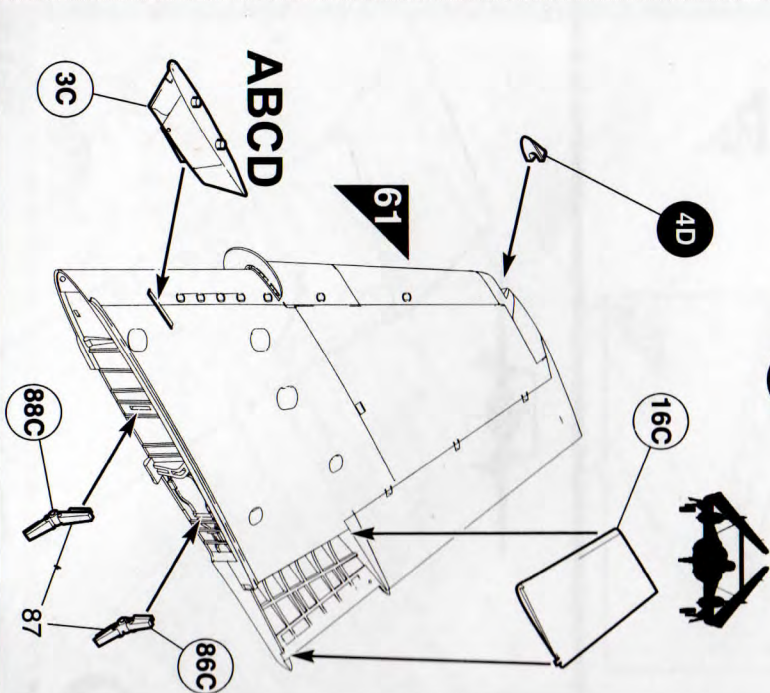
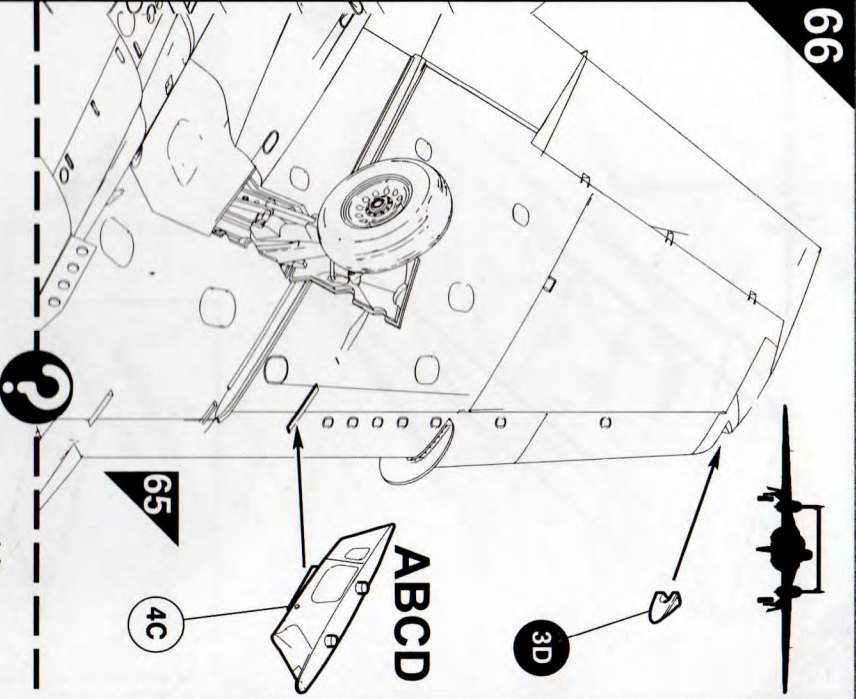

67



68

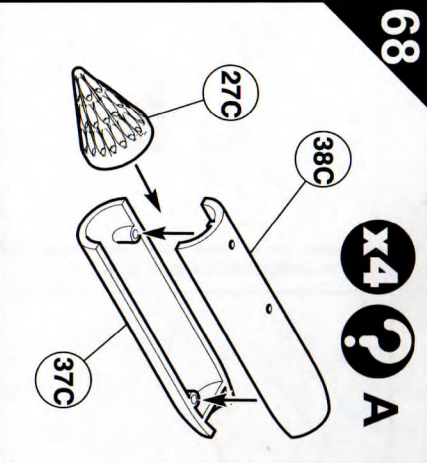

69

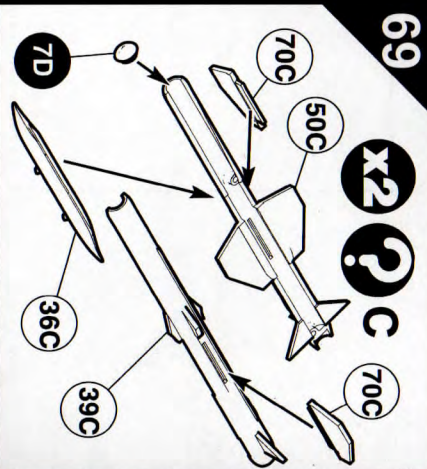

70

ABC

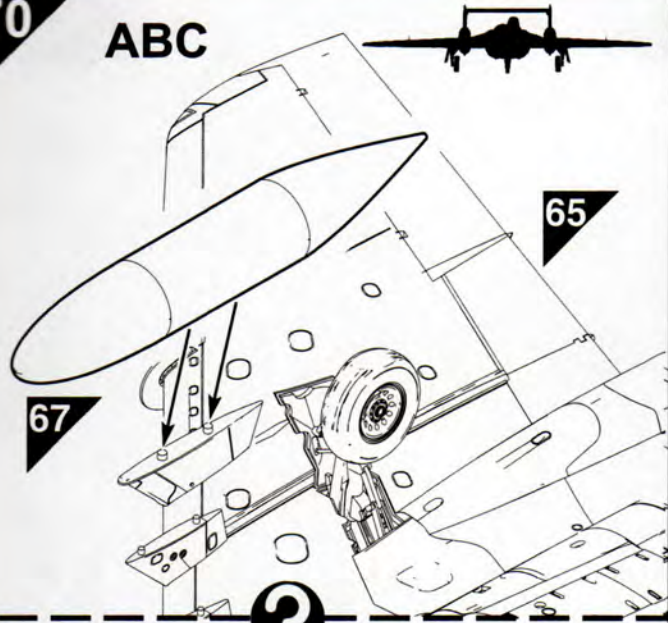

71

ABC

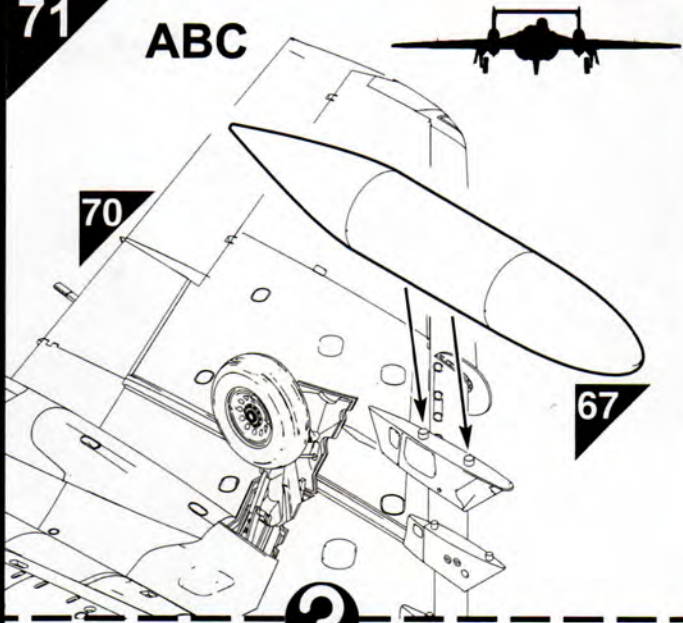

ABC

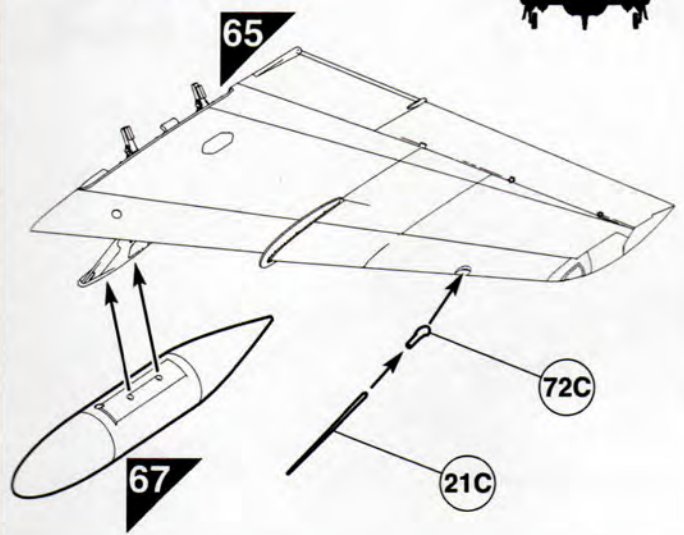

ABC

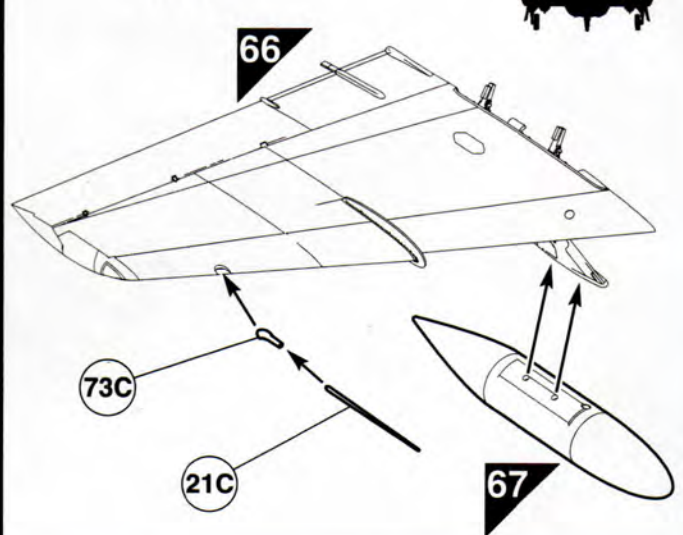

72

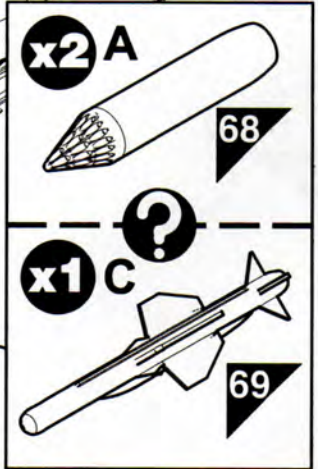
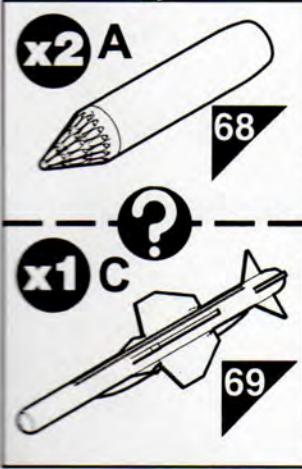
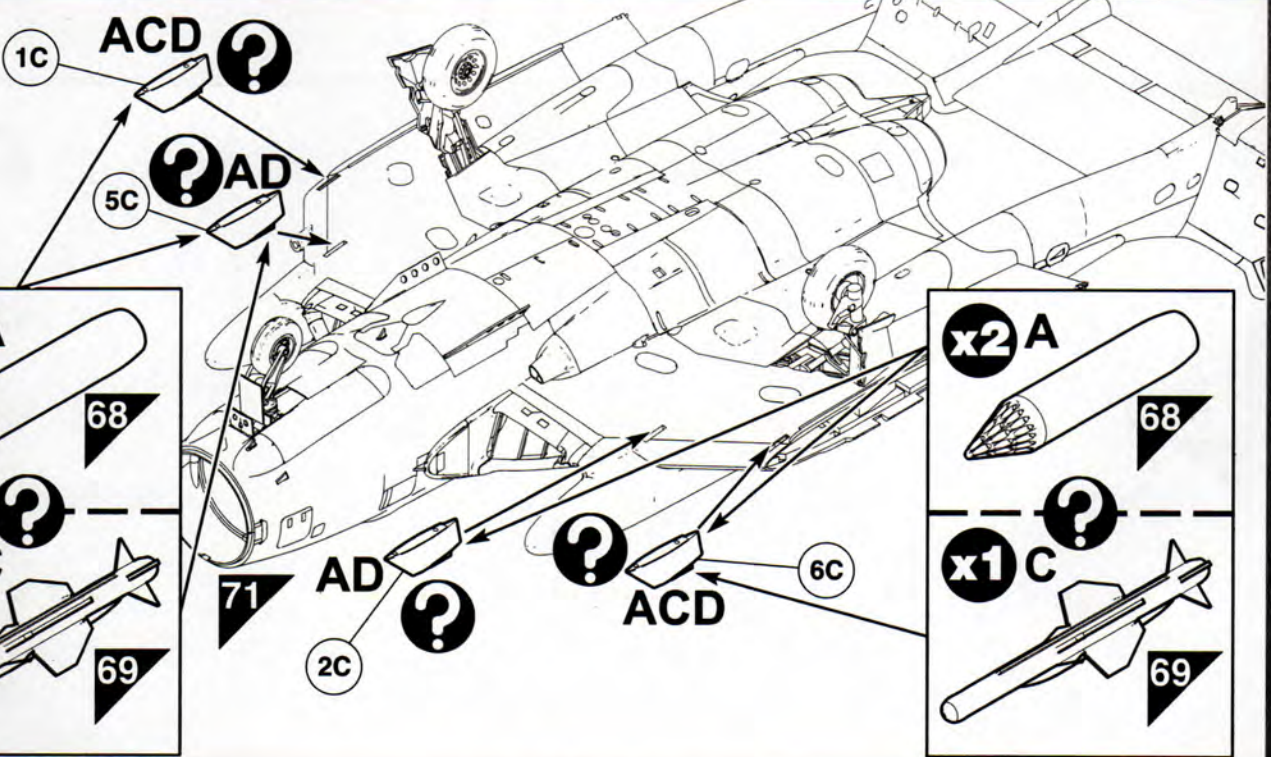

73

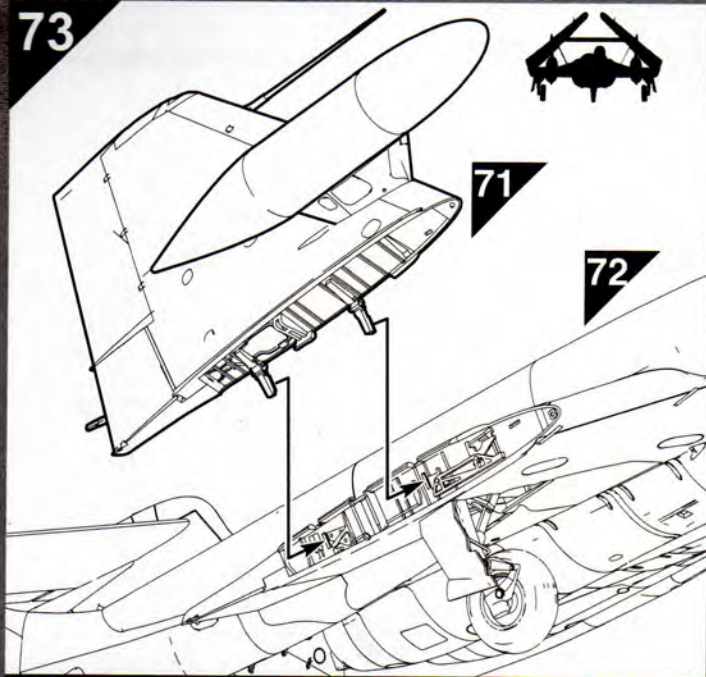

74

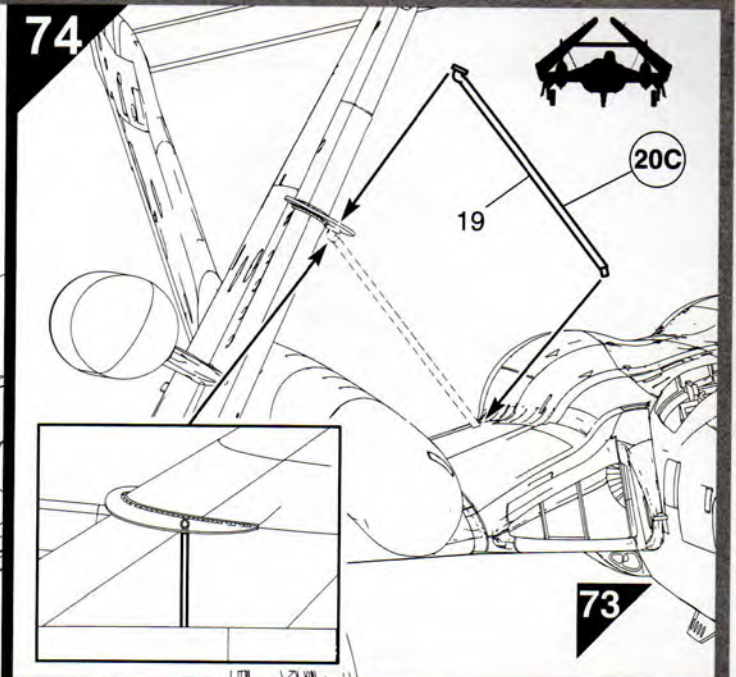

75

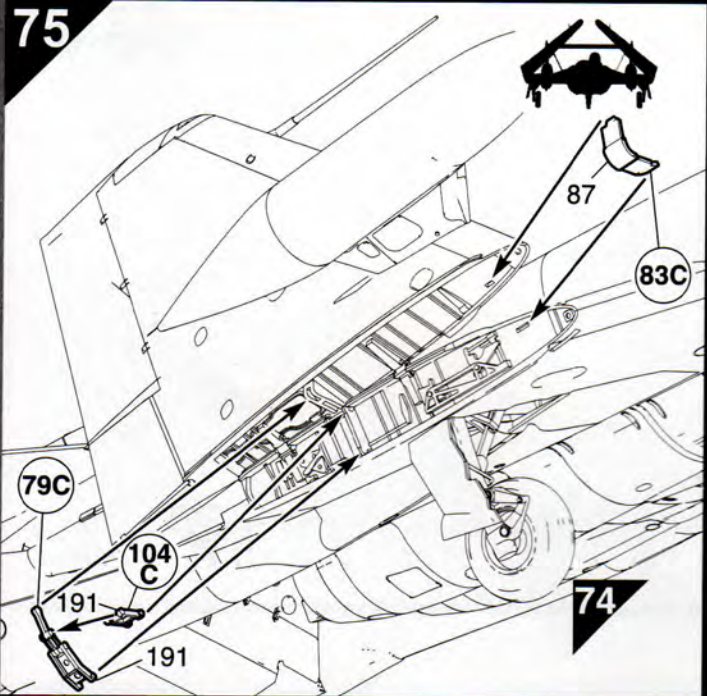

76

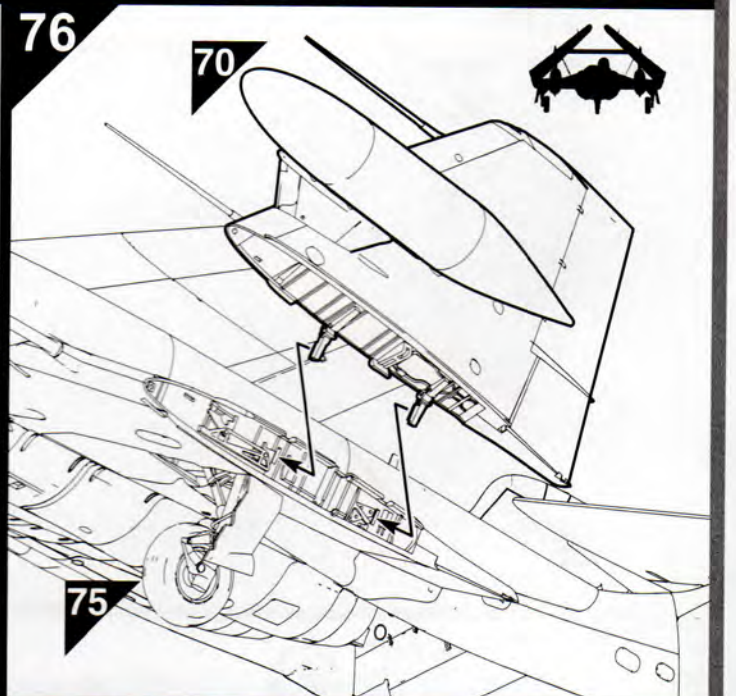

77

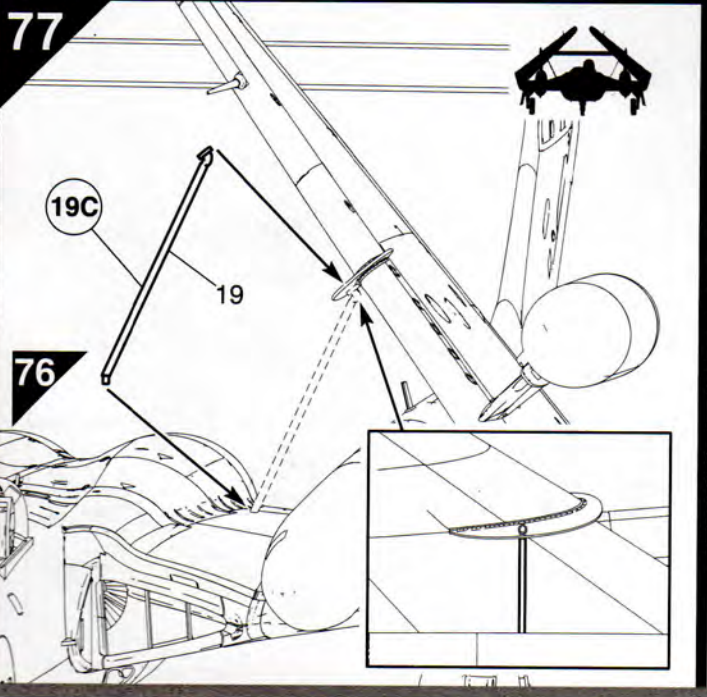

78

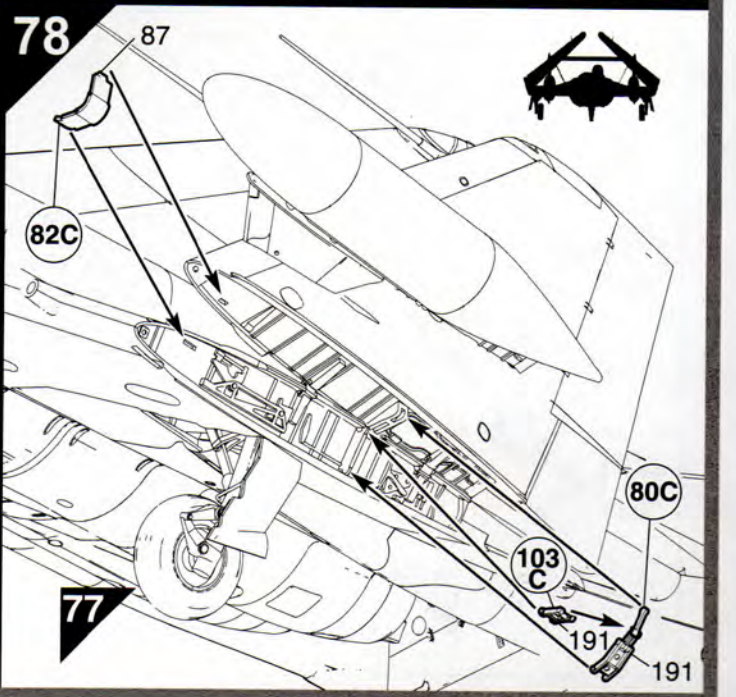

79

80

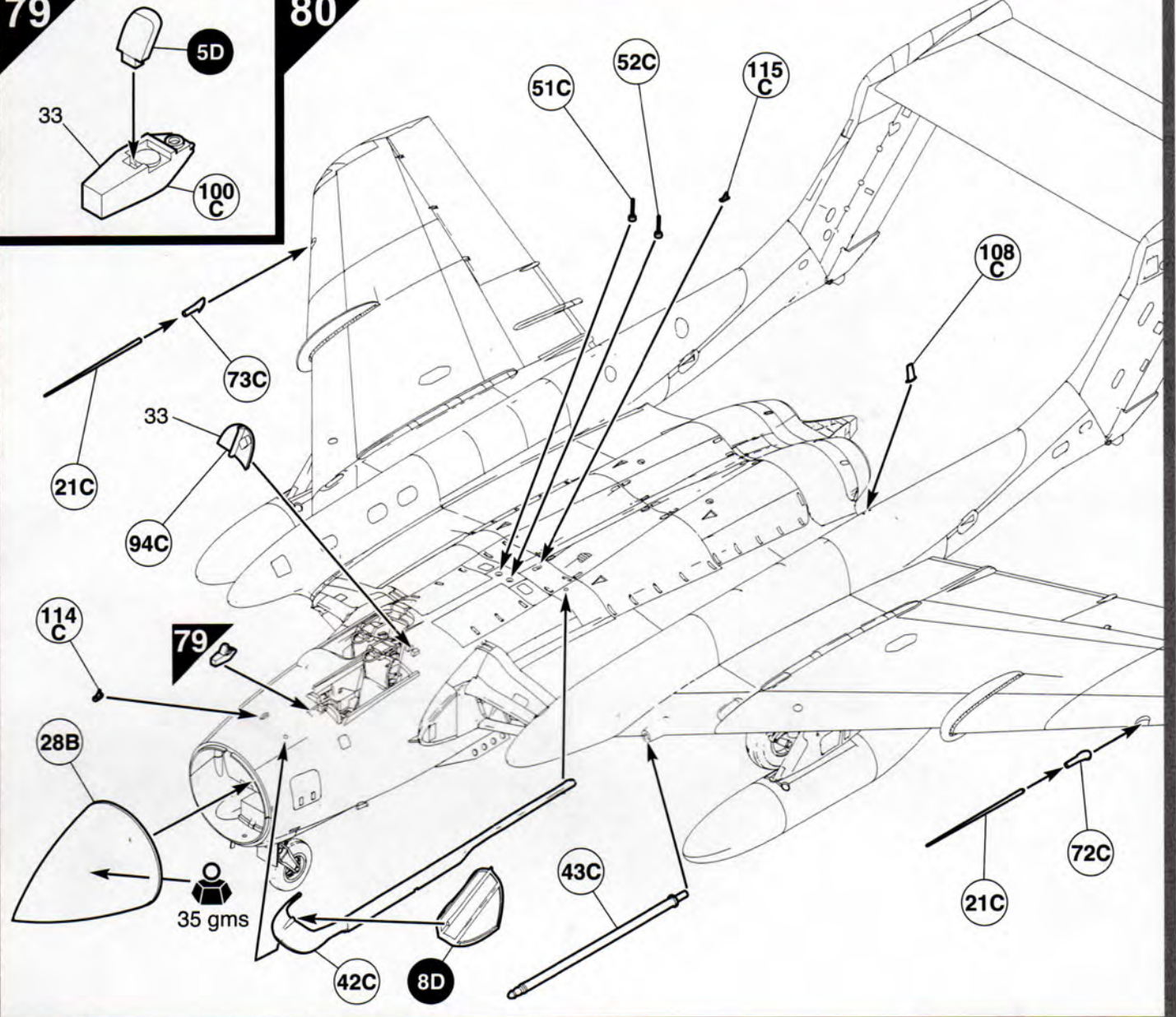

81



82

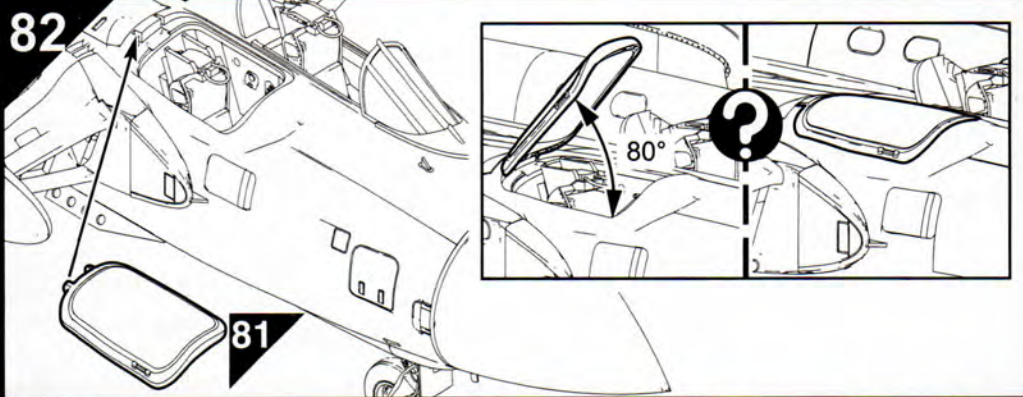

83

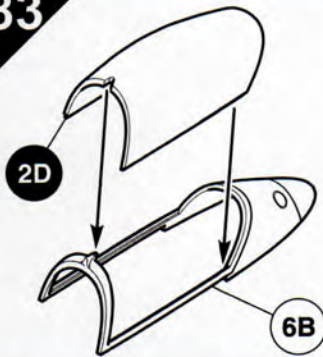

84

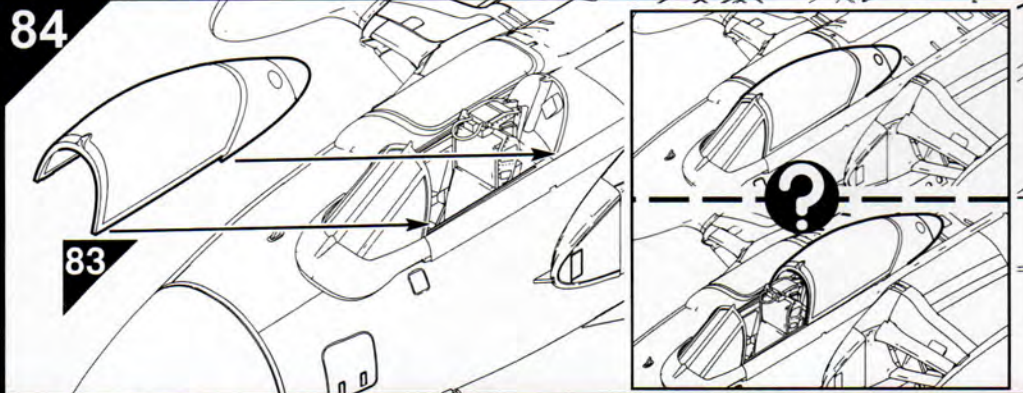

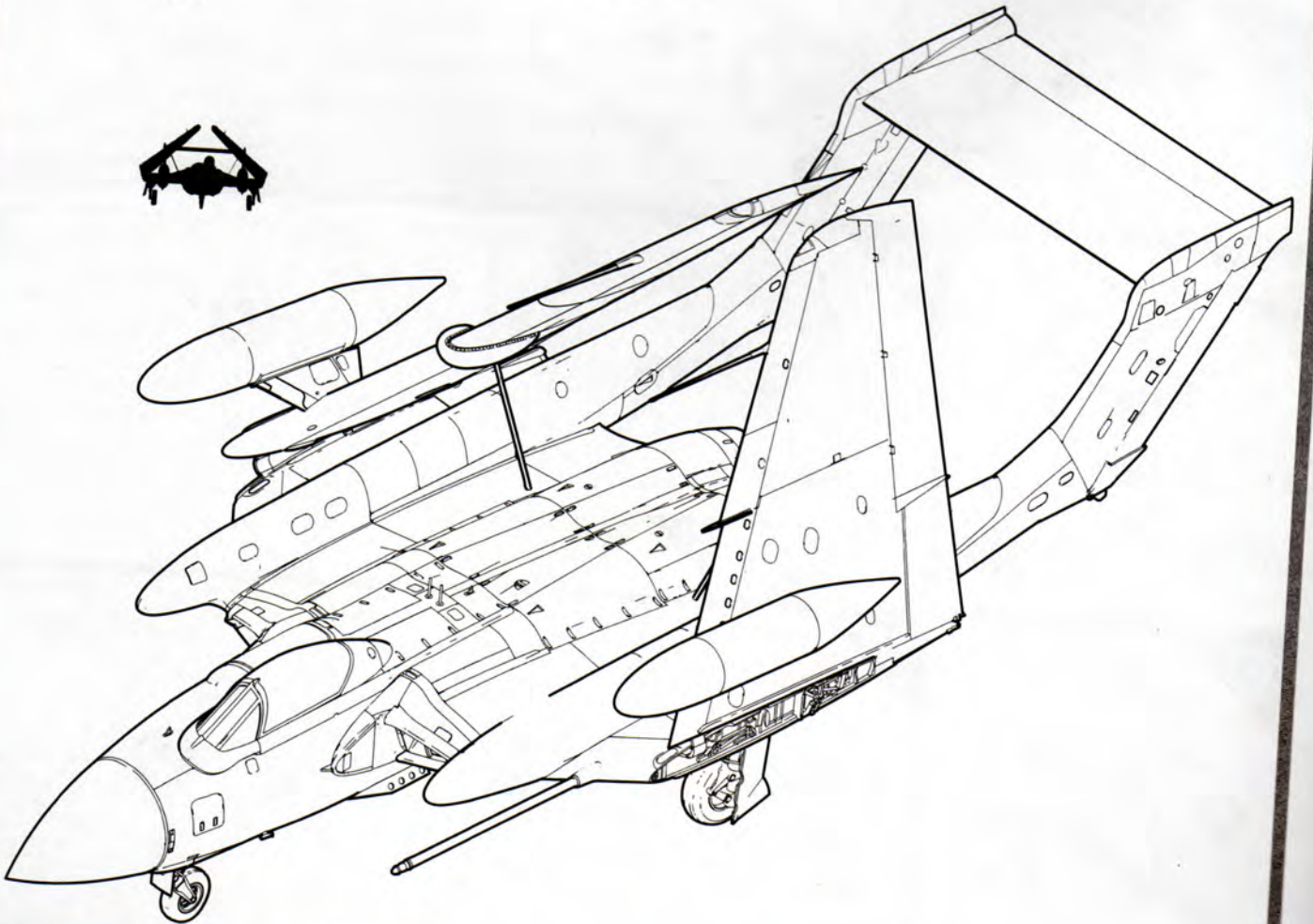
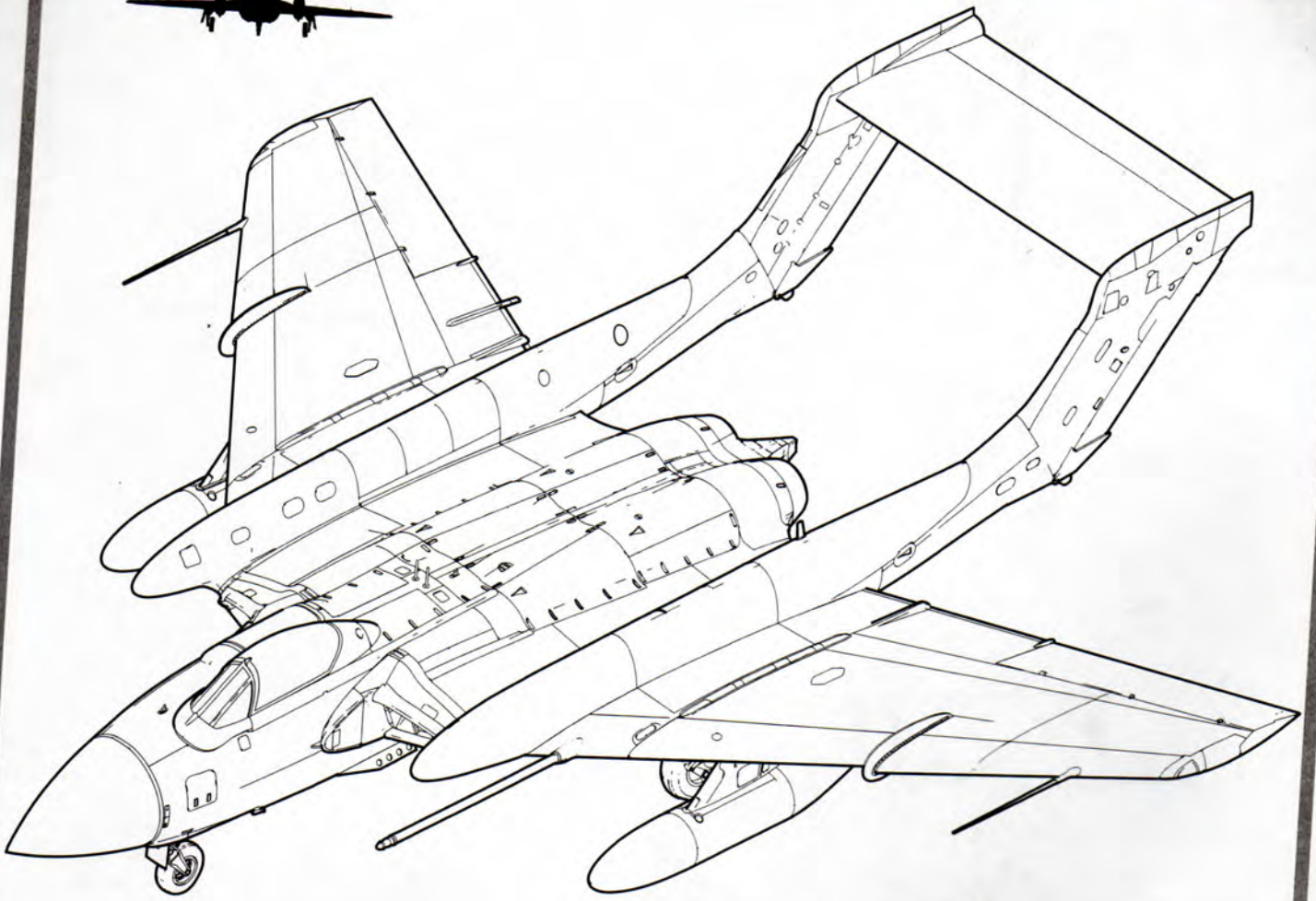

(A) (B) (C) de Havilland Sea Vixen FAW.2 Position of stencil data

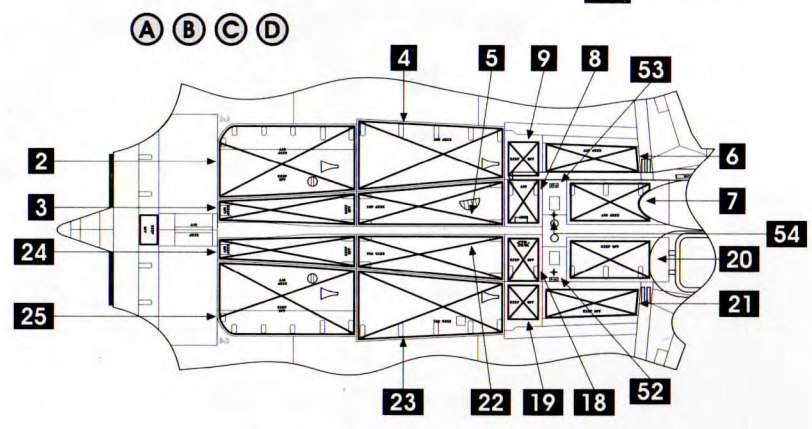
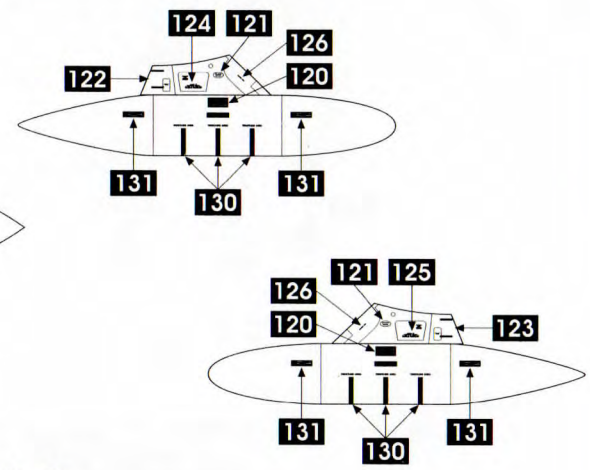
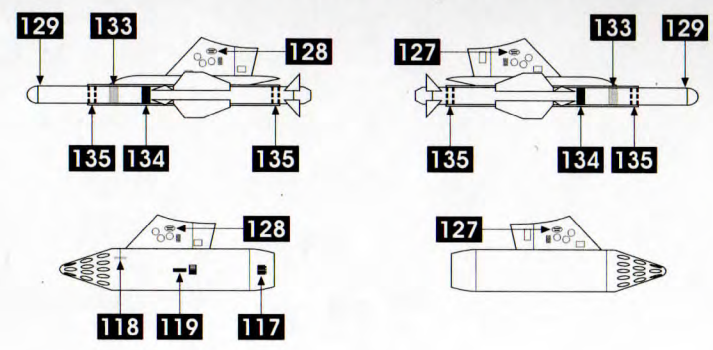
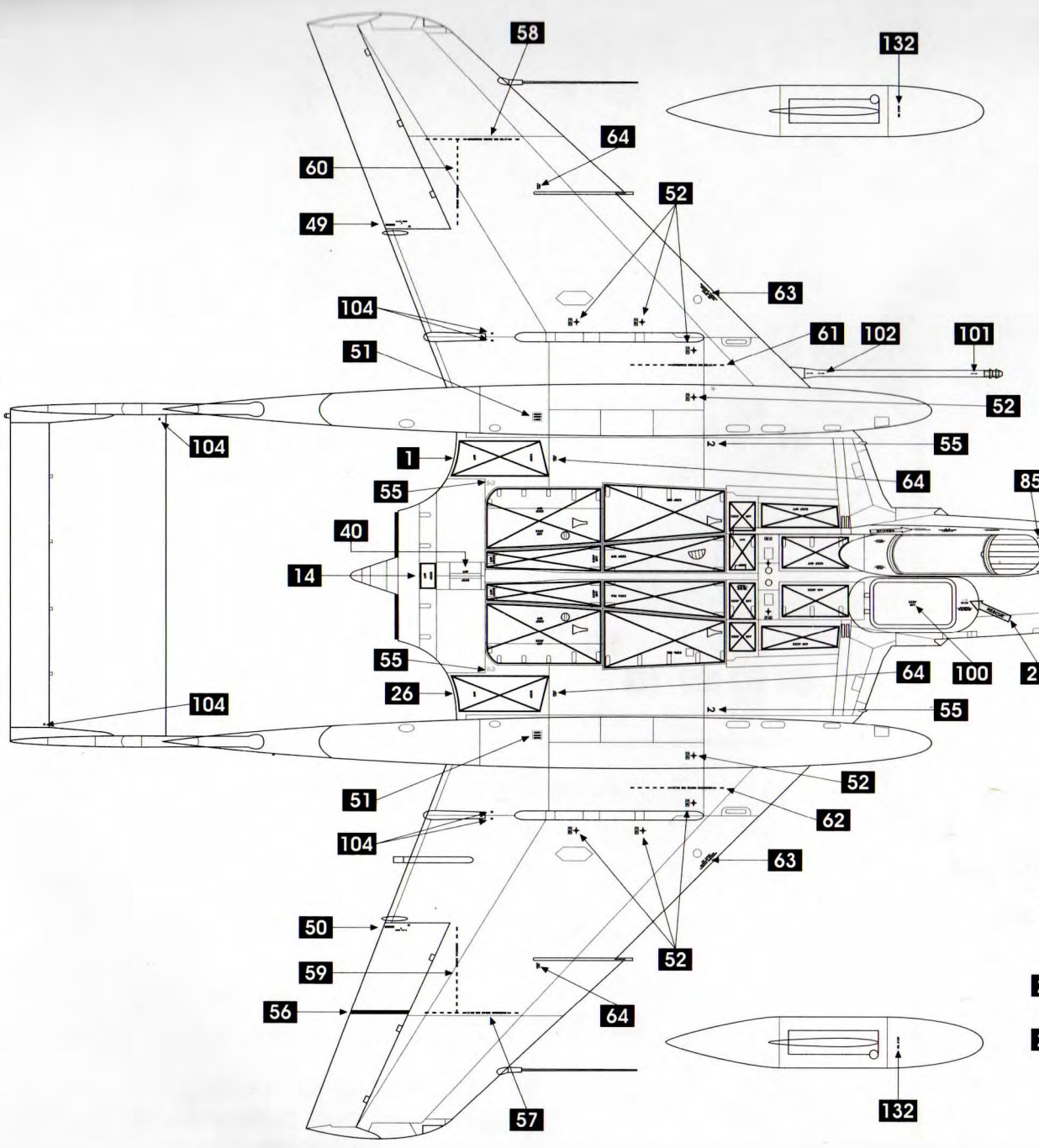

A B C de Havilland Sea Vixen FAW.2
 Position of stencil data

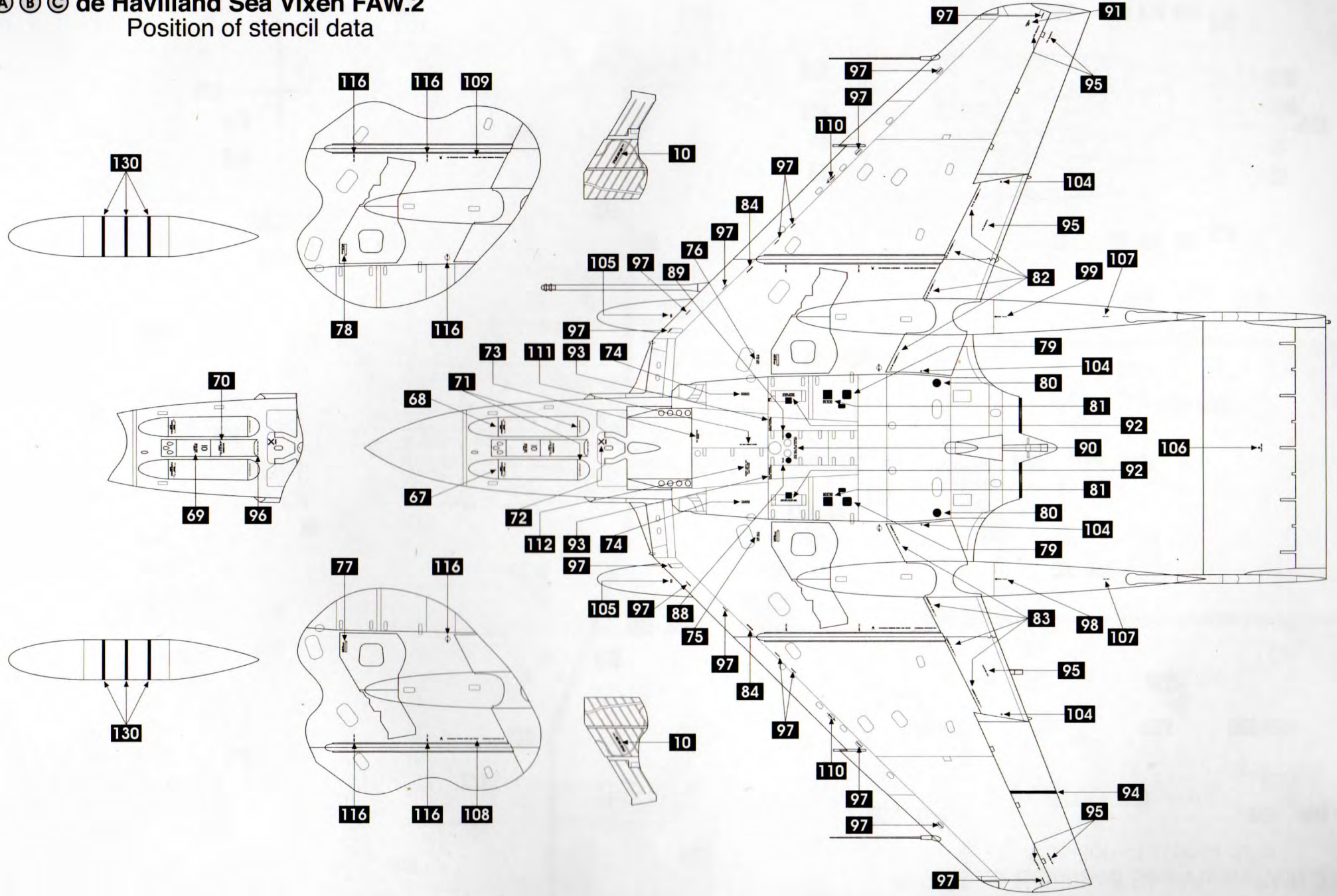

22

Ⓐ Ⓑ Ⓒ de Havilland Sea Vixen FAW.2
Position of stencil data

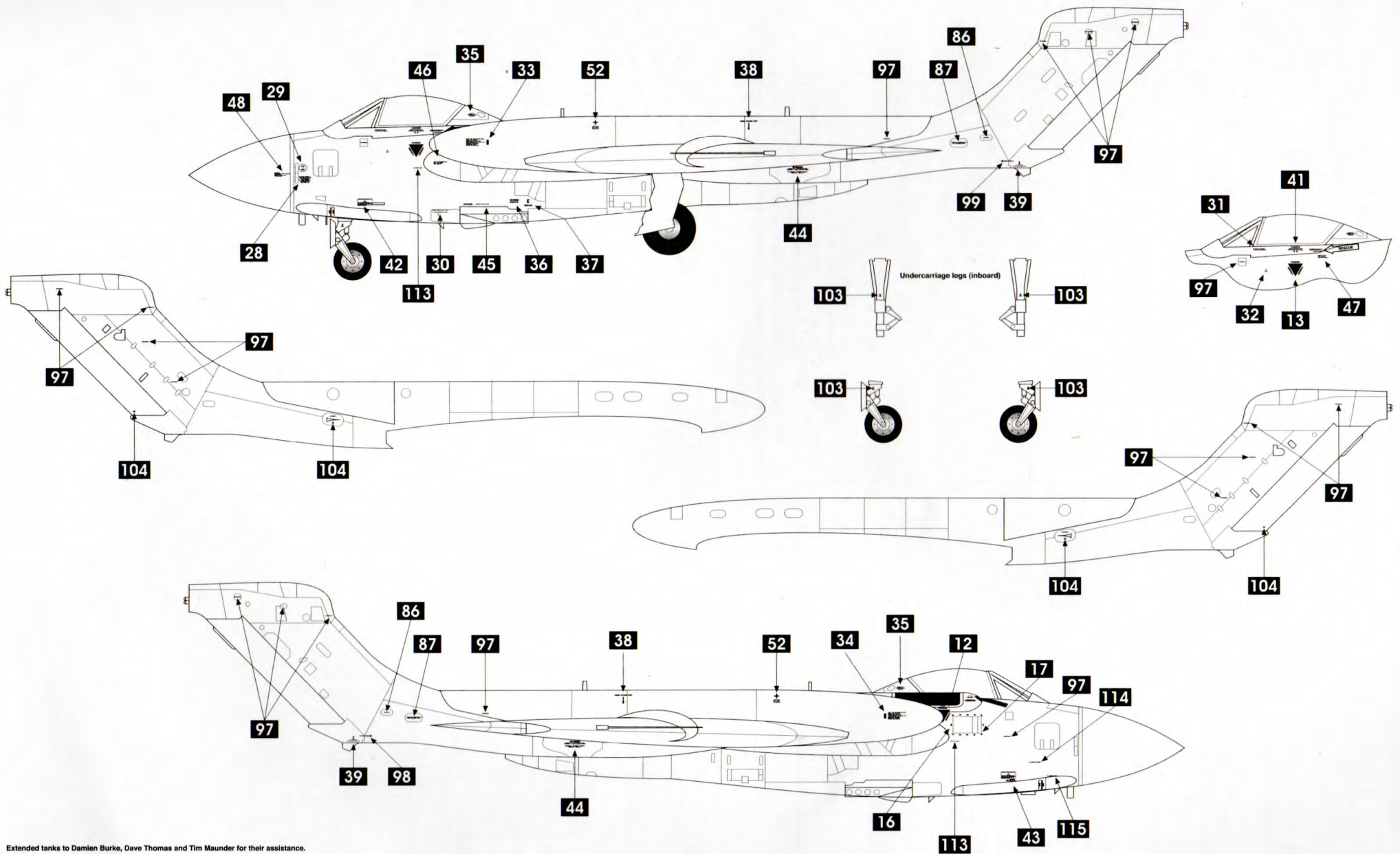

Extended tanks to Damien Burke, Dave Thomas and Tim Maunder for their assistance.



A de Havilland Sea Vixen FAW.2

No.899 Naval Air Squadron, HMS Eagle, March, 1975.

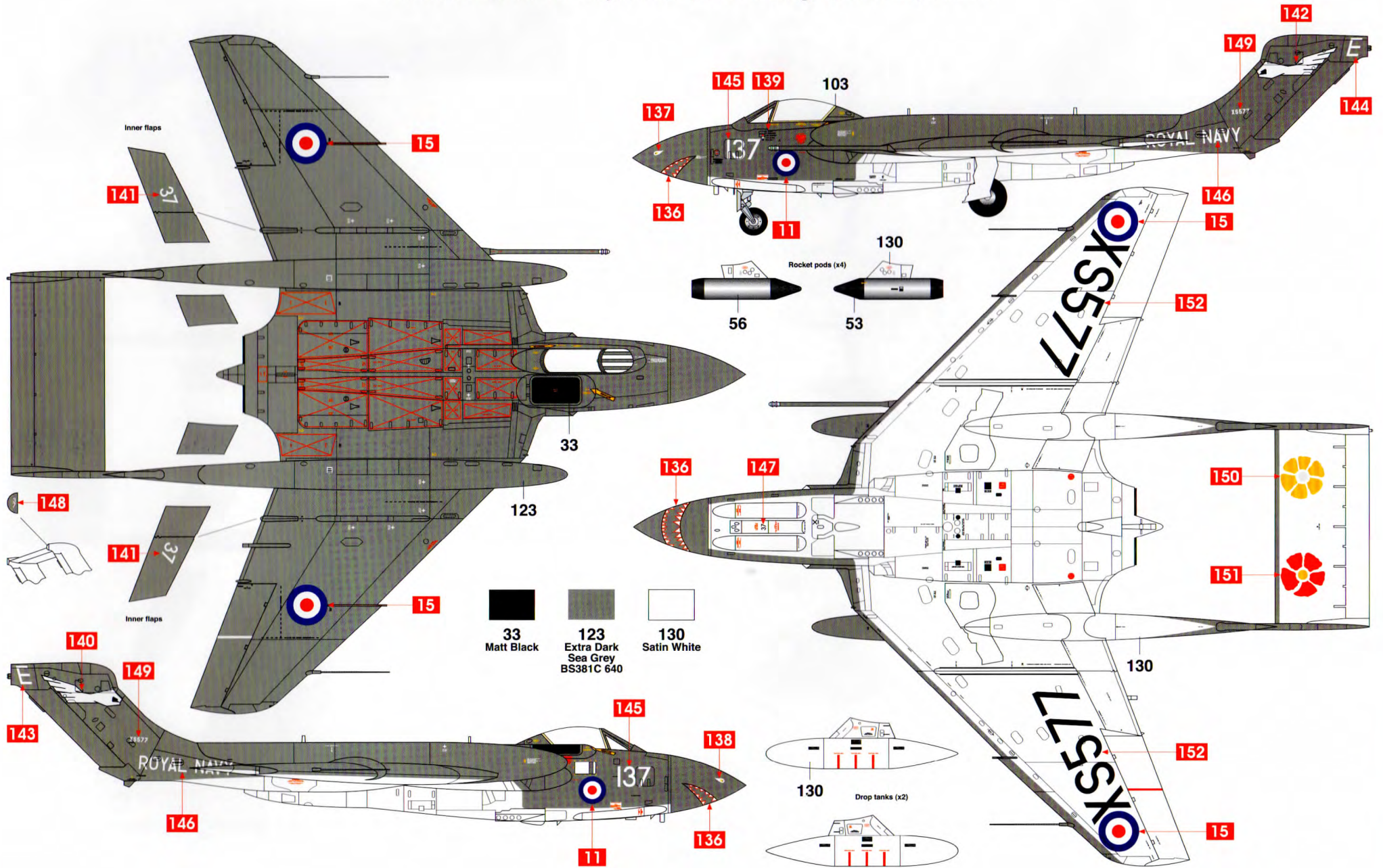

- 33 Matt Black
- 123 Extra Dark Sea Grey BS381C 640
- 130 Satin White

B de Havilland Sea Vixen FAW.2

"Simon's Circus", No.892 Naval Air Squadron, Royal Naval Air Station Yeovilton, Somerset, England, 1968.

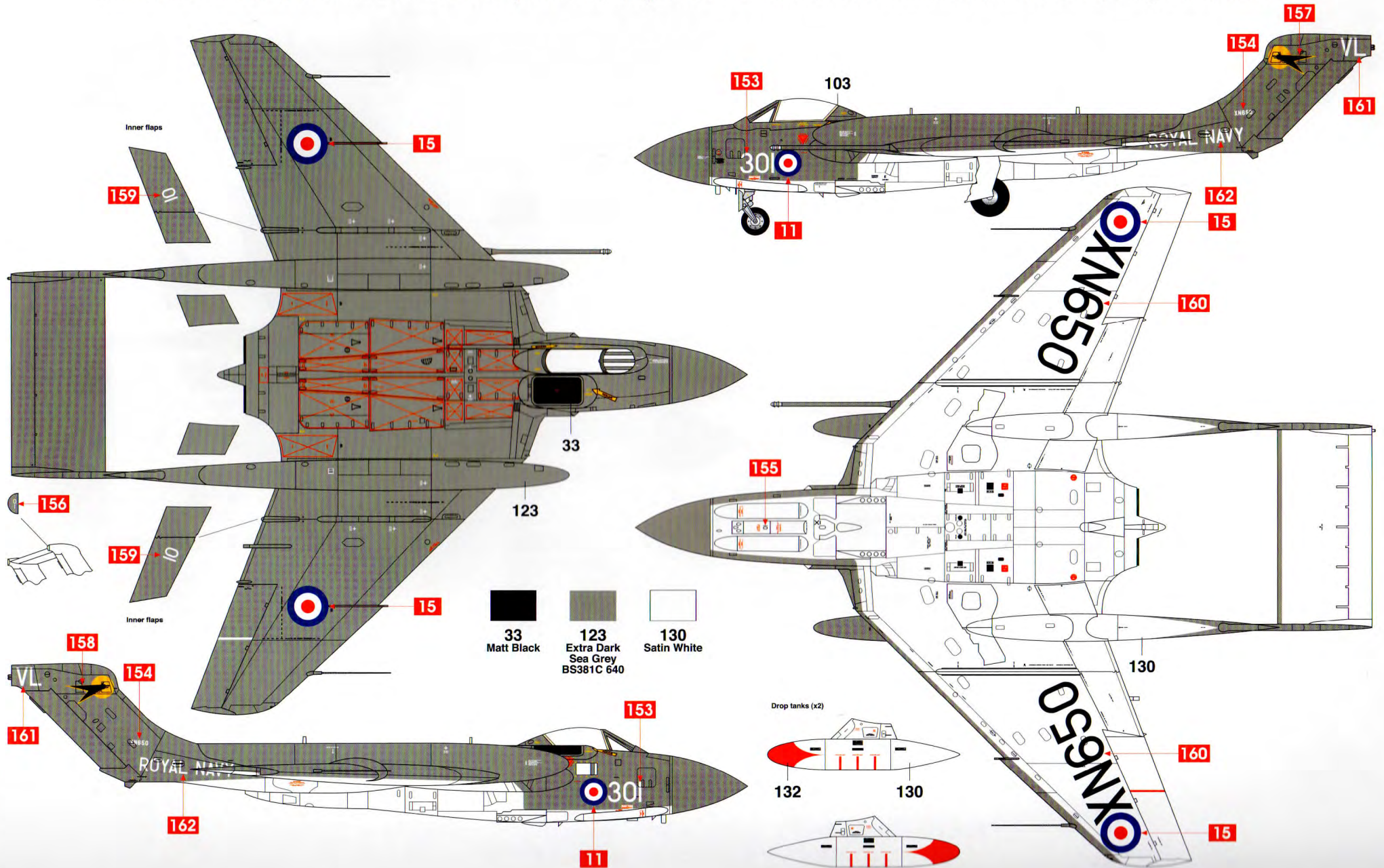

© de Havilland Sea Vixen FAW.2 No.893 Naval Air Squadron, HMS Victorious, 1966.

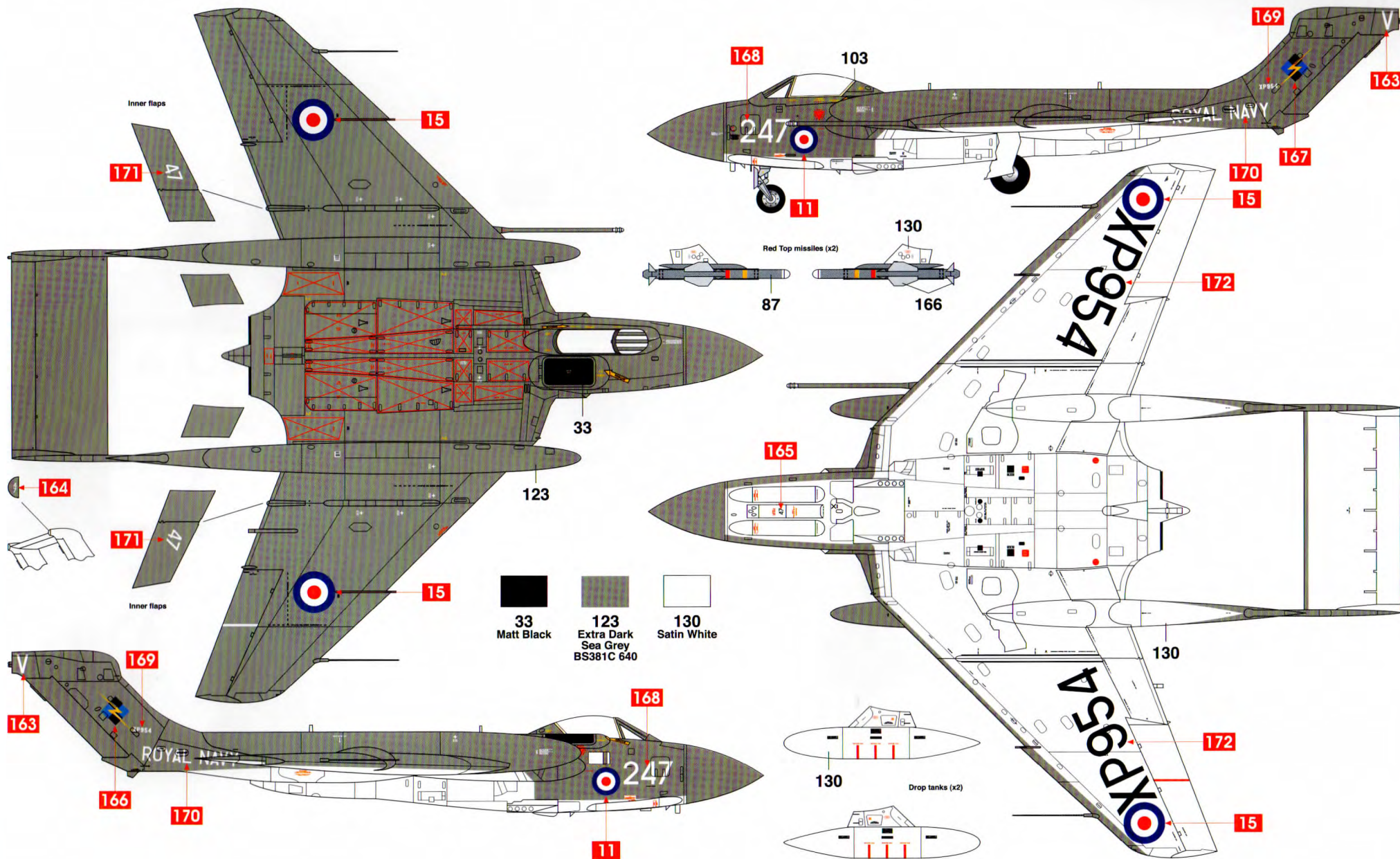

de Havilland Sea Vixen FAW.2 G-CVIX 2010

