

# Mustang Mk.IV

eduard

1/48 Scale Plastic Model Kit

**ProfiPACK**  
edition



item No. 82104

**Designed in 1940, in service until 1984... The life of one of the most famous fighter planes of all the time is extremely long and successful story initiated by the request from the British Buying Comitee in 1940.**

While Germans were marching through the Europe, all the British plants were running at full speed to produce fighters and bombers in preparations for the inevitable clash. The RAF had its Spitfires and Hurricanes but did not want to waste them for strafing or reconnaissance purposes and so the source of suitable aircraft was sought elsewhere. USA had the capacity and technological level for such a supply, but only Bell P-39 Airacobra and Curtiss P-40 Tomahawk were found by RAF satisfactory, although far from perfect. More to it, the Curtiss had no capacity to built P-40s for RAF, so the North American Aviation (NAA) was approached by Britons with request to do so. NAA president James Kindelberger offered development of completely new plane instead and after the preliminary work by design team led by chief designer Edgar Schmued (German born Austrian), the Britons agreed.

The preliminary design was approved on May 4, 1940, final assembly and engine installation began on September 9 (just 127 days after approval) and the first flight of the NA-73X prototype followed on October 26. The plane incorporated numerous novelties, like the laminar flow airfoil, but the engine used (Allison V-1710-39 V12) was supercharged by one stage compressor only which limited the effective use of the new plane to low and mid levels. RAF chose the Mustang name for the new type (which the US Army Air Corps adopted) and received its first Mk.IIs in October, 1941. The performance was found satisfactory, as the Mustang was faster than the Spitfire Mk.V and had more than double the range.

Several Allison powered P-51 Mustang variants were developed, even the dive bomber A-36, and they were considered a very good design, apart of aforementioned altitude limitations. To expand its versatility, the work began in Britain to fit the two-stage supercharged Merlin engine into the Mustang Mk.I. The trials of the prototype were promising and both RAF as well as USAAF were interested. As there was no capacity for additional Merlin production in the UK, the Packard, company already building the Merlins under license, was approached and the NAA team started to design Merlin powered Mustang. For even more range, 85gallon tank was installed behind the pilot's seat. The production started at the Inglewood plant as P-51B on May and the new production line at NAA Dallas plant started to make P-51C in August, 1943. Also the supplies to RAF continued as Mustang Mk. III.

#### **D as "Definitive"**

The P-51B/C were great fighters but lacked backward visibility and suffered with gun jamming, so the design team of NAA decided to rework the Mustang again. The main change was the bubble canopy with lowered rear fuselage. The wing was reworked to accommodate six .50 cal guns instead of just four and the new arrangement of ammo chutes eliminated the jam problem. Together with some other changes, the new P-51D (Mustang Mk.IV for RAF) was born at the end of 1943 and the production started at both Inglewood (production blocks with -NA suffix) and Dallas (-NT) plants. The D-5 was the first production batch apart of the -INA (100 unassembled Mustangs shipped for Australia).

The 5 series retained the shape of the vertical fin from P-51B/C, but it caused problems with longitudinal stability due to the reduced rear-side surface area of the fuselage. Adding the dorsal fin solved the problem and factory production P-51Ds obtained it starting with P-51D-10 series, while field conversion kit was distributed to the units already using P-51D-5s. Other significant change to 10 series was new gyroscopic gunsight K-14 instead of older N-9 reflexive one. For 20 series the cover of the elevator changed from fabric to aluminium (from February, 1945). During production also the battery moved from rear side of the cockpit to the nose, making room for the IFF system (Identification Friend or Foe). Starting from the 25 series the wings were fitted with attachment points for various forms of rockets and rocket launchers to add the firepower for ground attacks. There were many other, rather minor changes in production blocks, reflecting specific demands of the theatre or use. For example the recon version F-6D/K and the Mustangs used in CBI (Indochina) theatre were fitted with the direction finder system with distinctive ring aerial. On the other hand, the P-51K Mustang was essentially a P-51D with a different propeller (Aeroproduct instead of Hamilton Standard). Only Dallas factory produced the K variant. The RAF variant of P-51K was marked Mk.IVa.

#### **Luftwaffe killers and Tokyo Club**

The P-51D became the true ruler of the skies wherever it appeared, serving as the escort and patrol fighter, and also in ground attack or reconnaissance role (F-6 variants). One of the most significant tasks of P-51D (production blocks 20 and 25) were very long-range raids to the Tokyo, conducted by the 15th, 26th and 506th Fighting Groups of 7th Fighter Command (The Sunsetters). In European theatre, the mighty 8th, 9th and 15th Air Force produced numerous aces with George J. Preddy Jr. being the highest scorer of all the P-51 pilots with 23,83 kills. In total, 8,102 P-51Ds and 1,500 of P-51Ks were produced. Many of them stayed operational after the WWII and served in pursuit and attack role even during the Korean War.

#### **The kit: Mustang Mk.IV and Mk.IVa**

The RAF had to wait for the Mustangs Mk.IV until late 1944, as the USAAF Fighter Groups had the priority of deliveries. First two Mustangs Mk.IV (TK586; TK589) were sent to RAF for evaluation in July 1944 and after that the first batch of thirty Mk.IVs and 200 of Mk.IVas was delivered between September 1944 and January 1945. The Mk.IVs were diverted from the Block 5 production and the Mk.IVas from the Block 1 and Block 5. Later on the British ordered another batch of 900 Mustangs Mk.IV and IVa of which 643 were delivered before the order was terminated in August 1945. These were 392 Mustangs Mk.IVa from Block 10 and Block 15 and 251 Mustangs Mk.IV from Block 20. All the aircraft were built by the Dallas factory and either painted in US colours camouflage or left in natural metal/silver paint finish. Some of the aircraft were later repainted in British camouflage scheme.

ATTENTION



UPOZORNĚNÍ



ACHTUNG



ATTENTION



注意



Carefully read instruction sheet before assembling. When you use glue or paint, do not use near open flame and use in well ventilated room. Keep out of reach of small children. Children must not be allowed to suck any part, or pull vinyl bag over the head.



Před započítím stavby si pečlivě prostudujte stavební návod. Při používání barev a lepidla pracujte v dobře větrané místnosti. Lepidla ani barvy nepoužívejte v blízkosti otevřeného ohně. Model není určen malým dětem, mohlo by dojít k požití drobných dílů.

INSTRUCTION SIGNS \* INSTR. SYMBOLS \* INSTRUKTION SINNBILDEN \* SYMBOLES \* 記号の説明

OPTIONAL  
VOLBABEND  
OHNOUTSAND  
BROUSITOPEN HOLE  
VYVRTAT OTVORSYMETRICAL ASSEMBLY  
SYMETRICKÁ MONTÁŽREMOVE  
ODŘÍZNOUTREVERSE SIDE  
OTOČITAPPLY EDUARD MASK  
AND PAINT  
POUŽIT EDUARD MASK  
NABARVIT

PARTS



DÍLY



TEILE



PIÈCES



部品

## PLASTIC PARTS

A&gt;

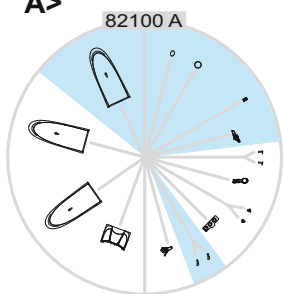

B&gt;

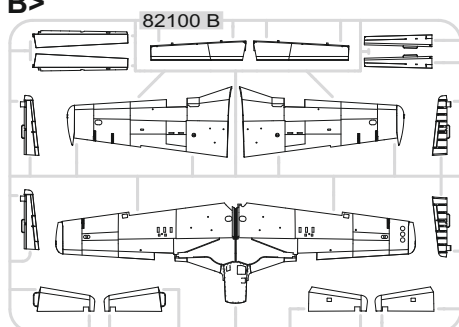

D&gt;

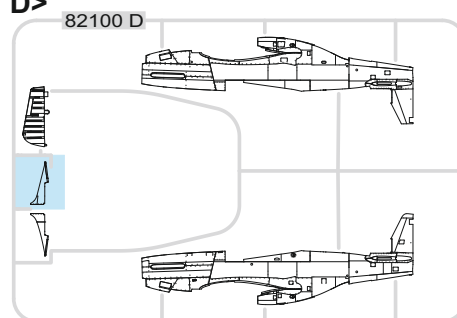

F&gt;

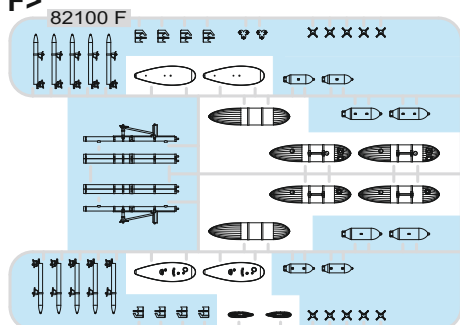

G&gt;

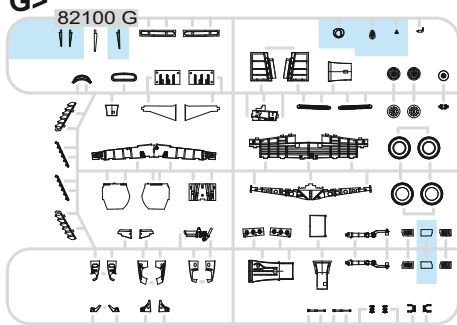

H&gt;

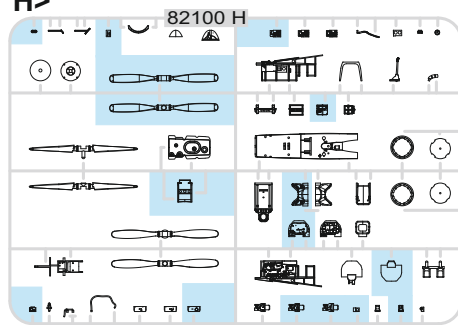

## PE - PHOTO ETCHED DETAIL PARTS

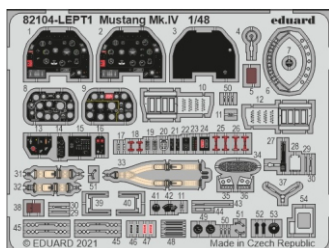
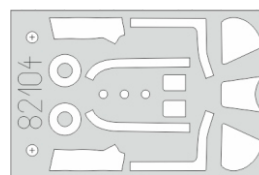
eduard  
MASK

-Parts not for use. -Teile werden nicht verwendet. -Pièces à ne pas utiliser. -Tyto díly nepoužívejte při stavbě. - 使用しない部品

COLOURS



BARVY



FARBEN



PEINTURE



色

GSI Creos (GUNZE)		MISSION MODELS	
AQUEOUS	Mr.COLOR	PAINTS	
H1	C1	MMP-001	WHITE
H8	C8		SILVER
H11	C62	MMP-001	FLAT WHITE
H12	C33	MMP-047	FLAT BLACK
H15	C65		BRIGHT BLUE
H25	C34		SKY BLUE
H27	C44		TAN
H37	C43		WOOD BROWN
H47	C41	MMP-012	RED BROWN
H52	C12	MMP-091	OLIVE DRAB
H53	C13		NEUTRAL GRAY
H57	C73		AIRCRAFT GRAY
H58	C351	MMP-059	INTERIOR GREEN
H74	C368	MMP-080	SKY
H77	C137	MMP-040	TIRE BLACK

GSI Creos (GUNZE)		MISSION MODELS	
AQUEOUS	Mr.COLOR	PAINTS	
H90	C47		CLEAR RED
H91	C48		CLEAR YELLOW
H94	C138		CLEAR GREEN
H327	C327	MMP-101	RED
H329	C329		YELLOW
H330	C361	MMP-077	DARK GREEN
H330	C361	MMP-077	DARK GREEN
H335	C363	MMP-094	MEDIUM SEAGRAY
	C352		YELLOW CHROMATE
	C362		OCEAN GRAY
Mr.METAL COLOR		METALLICS	
MC214		MMM-001	DARK IRON
Mr.COLOR SUPER METALLIC		METALLICS	
SM201		MMC-001	SUPER FINE SILVER
SM203			SUPER IRON

**A** 1 = 90% + 10%

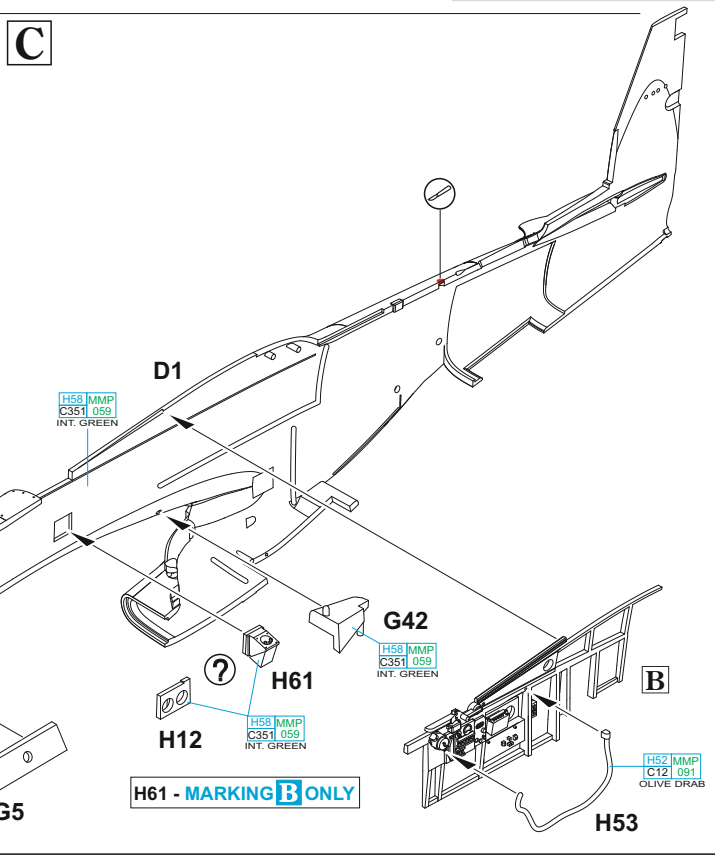
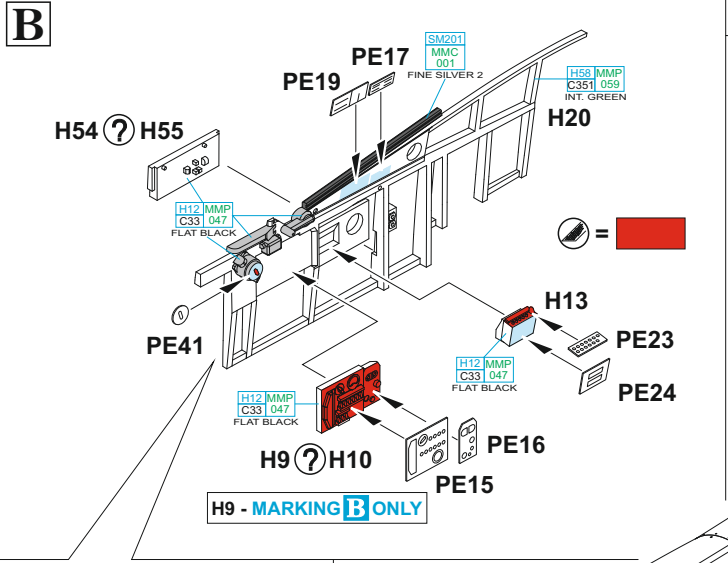
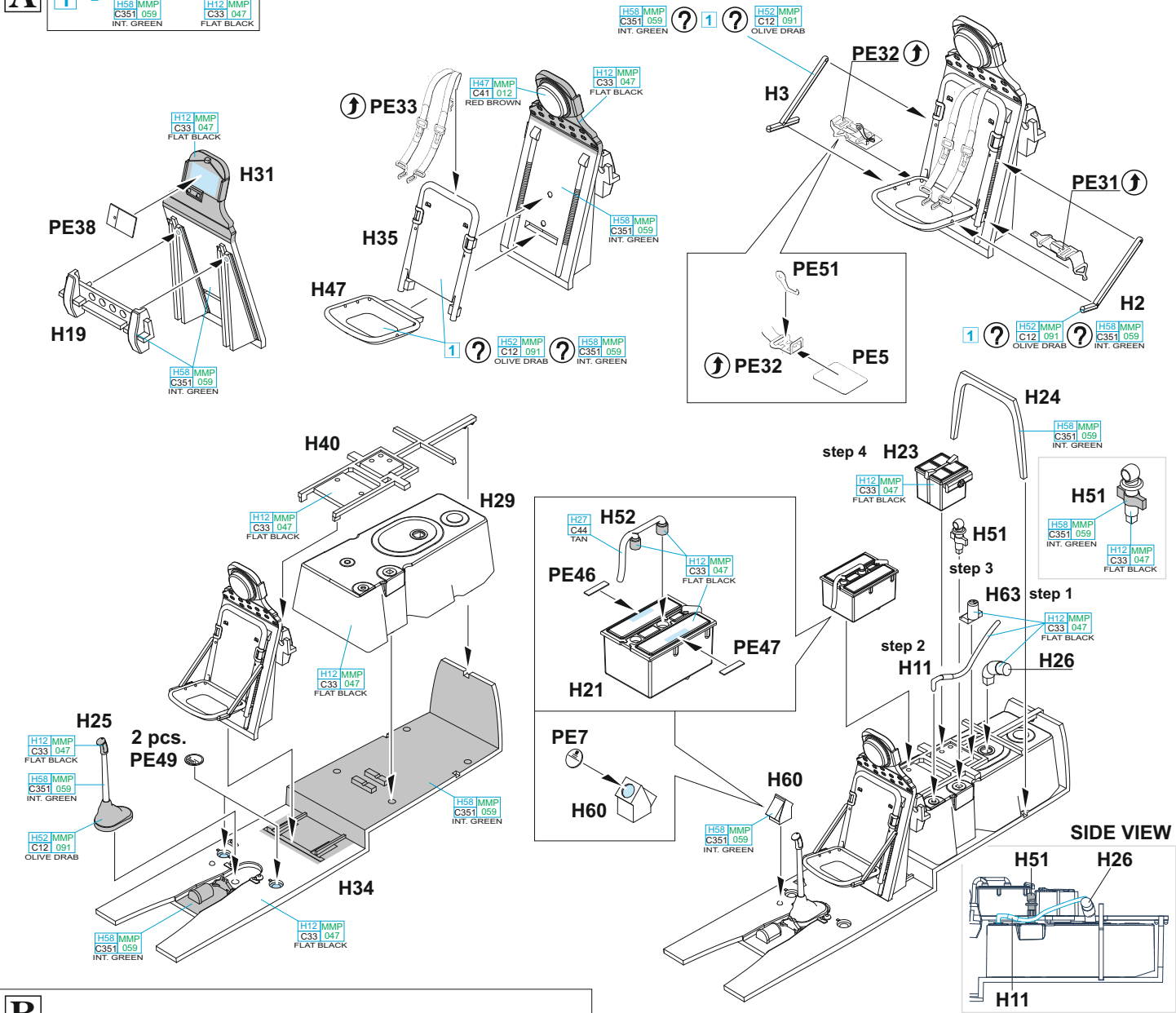

D

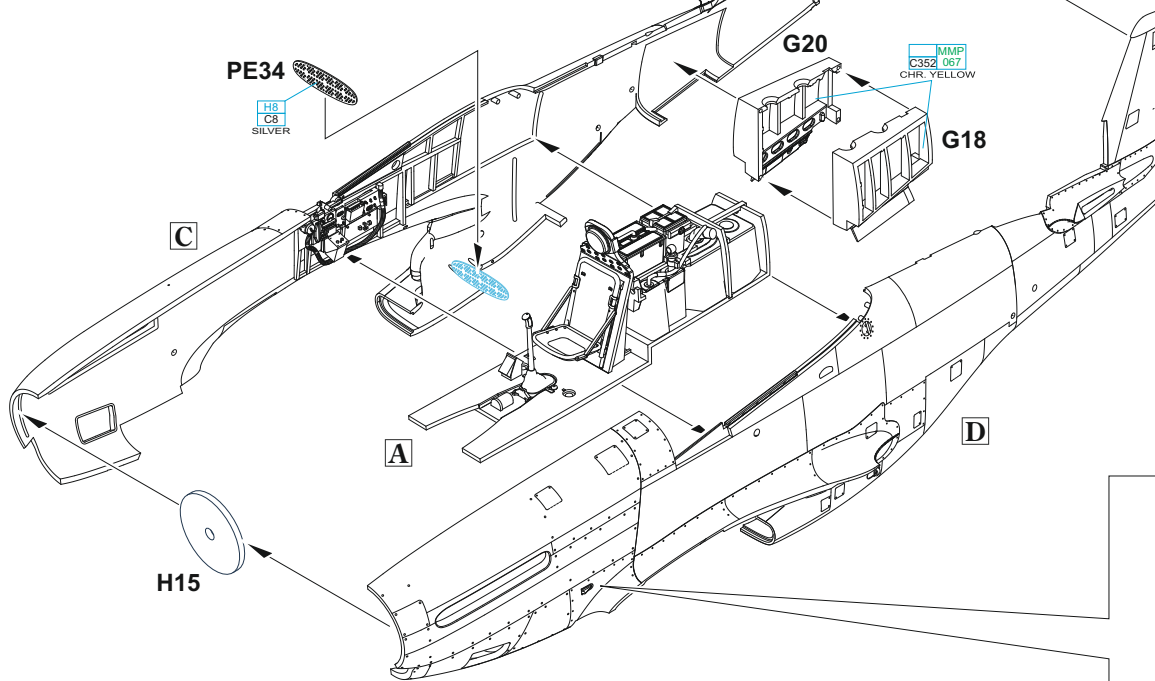
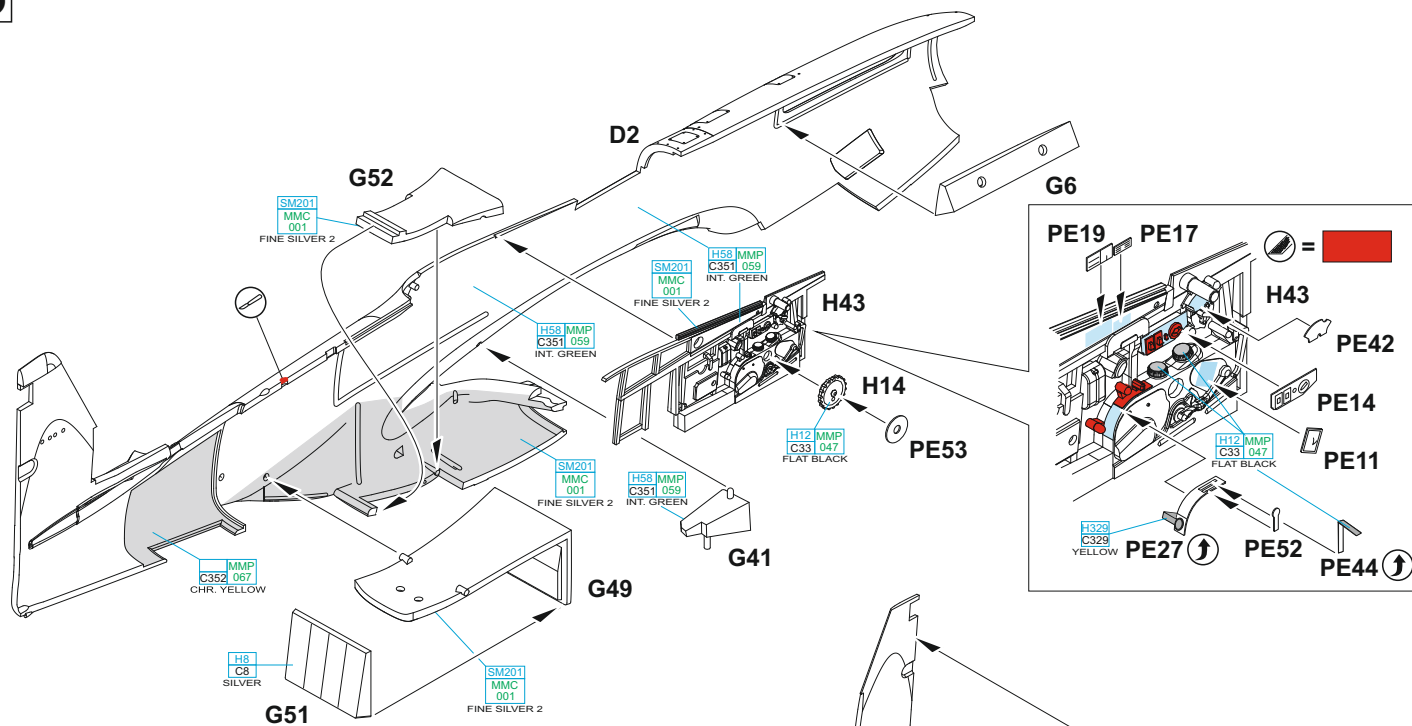

E

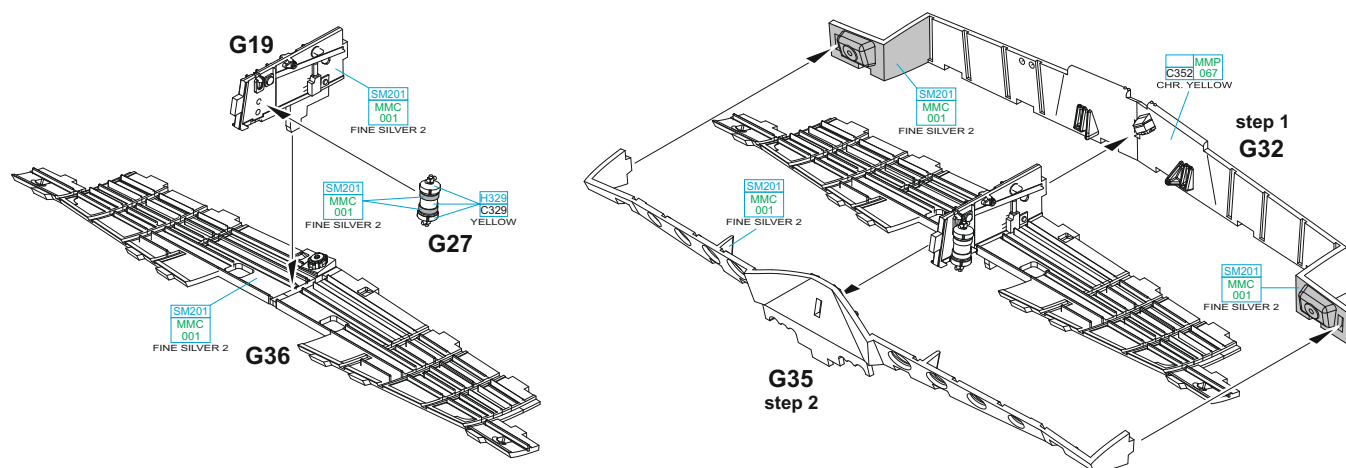



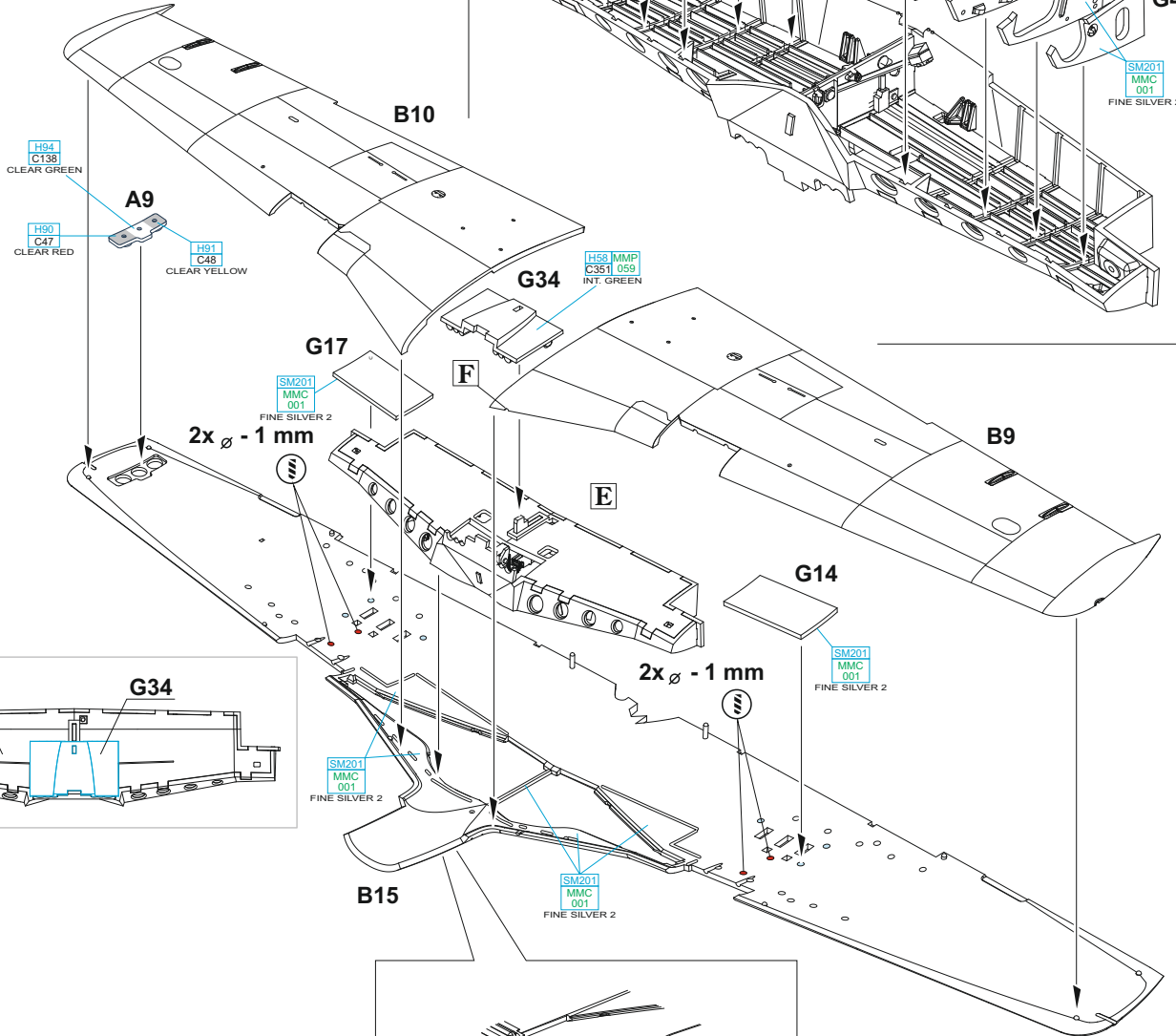
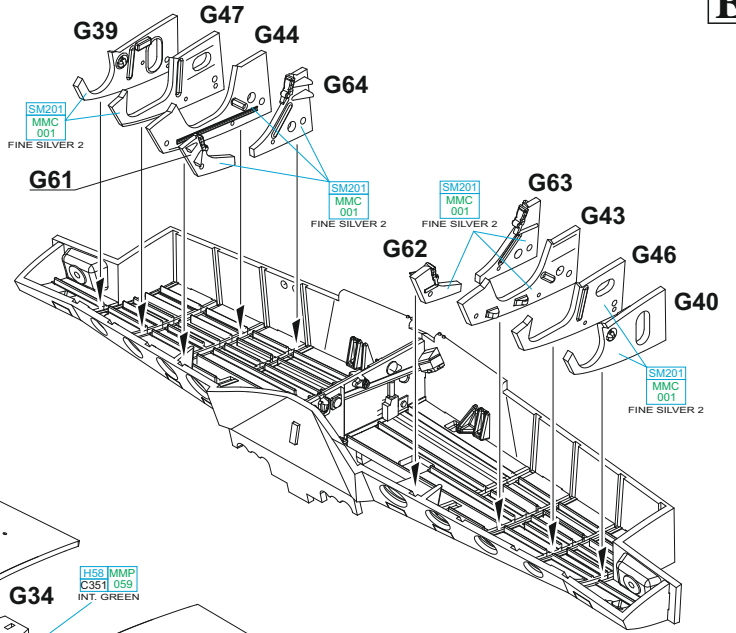
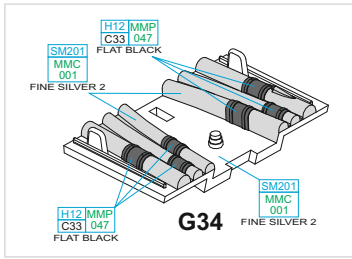

UPPER VIEW

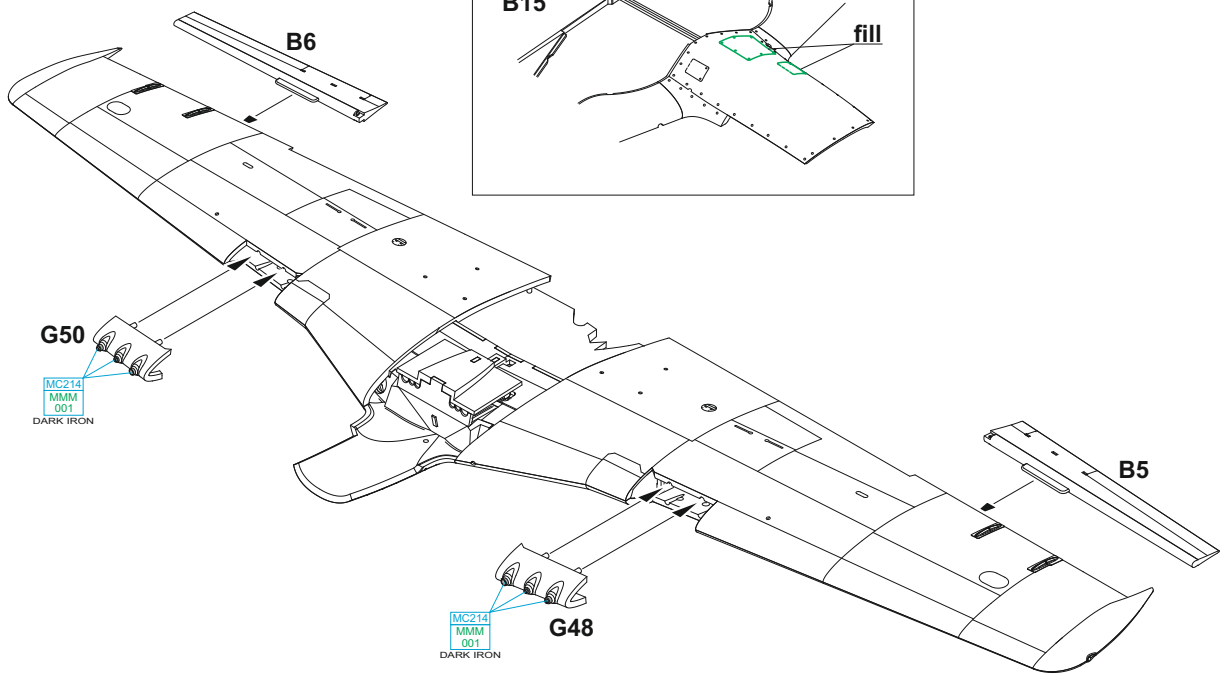
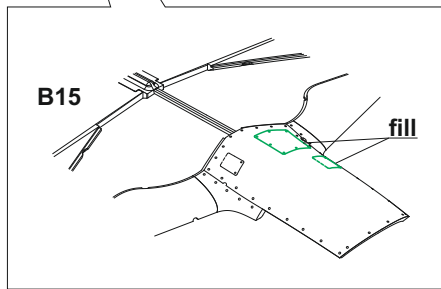
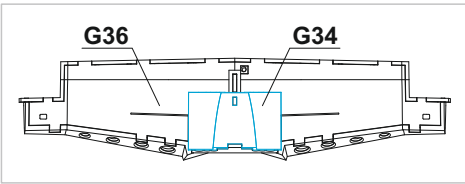

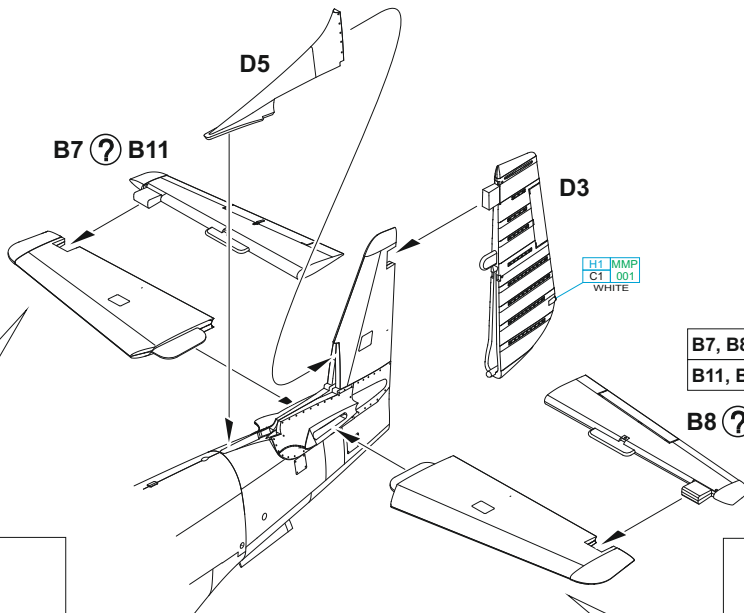
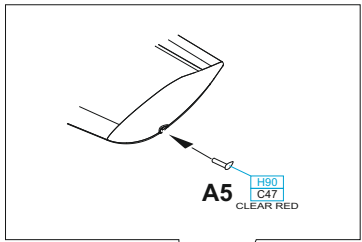
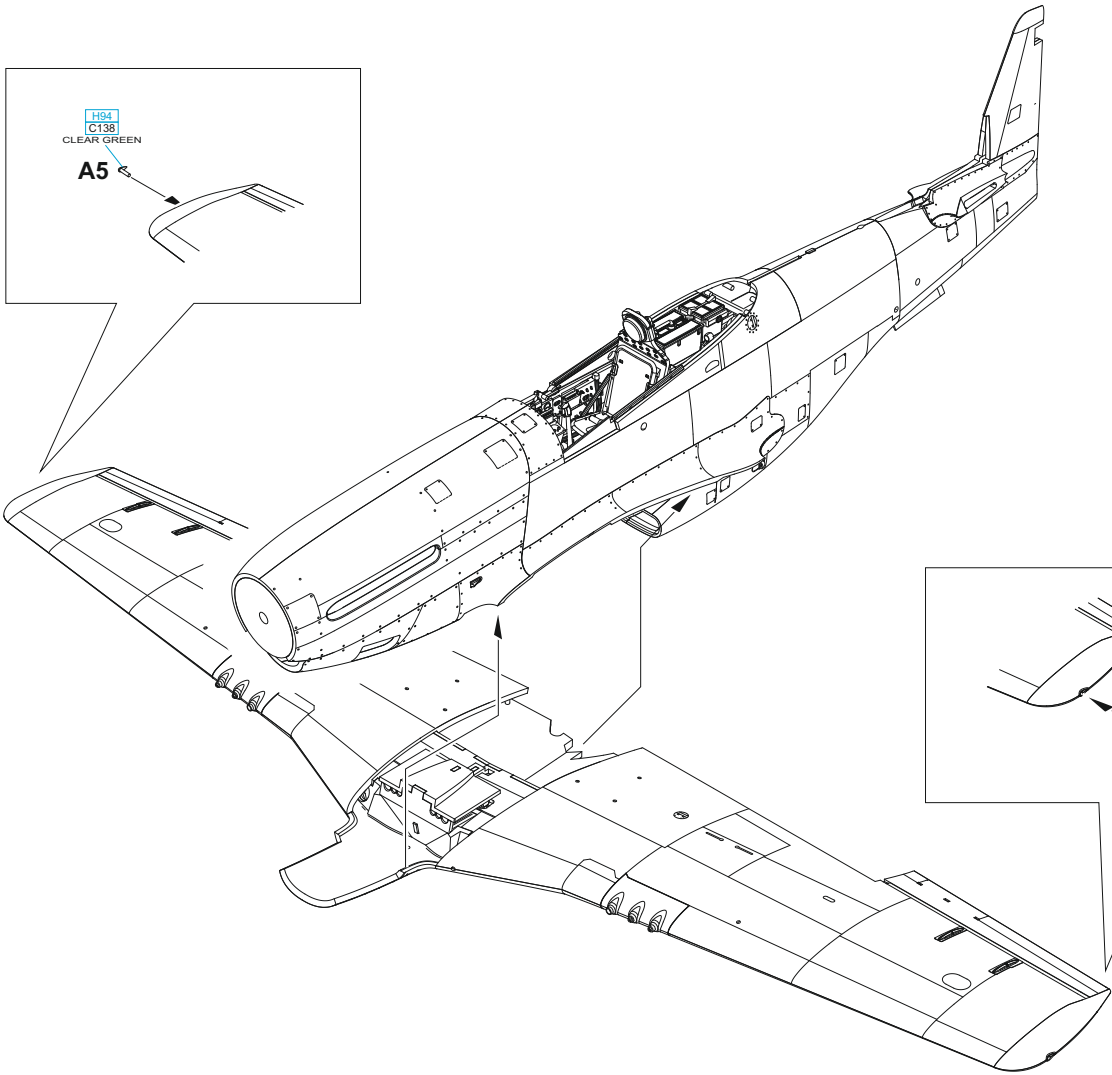
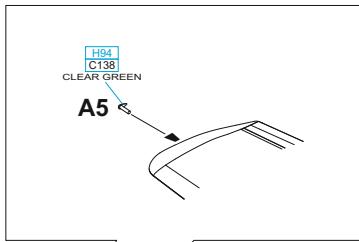

**B7, B8 - MARKINGS A, B, C, E, F**

**B11, B12 - MARKING D**

**B8 ? B12**

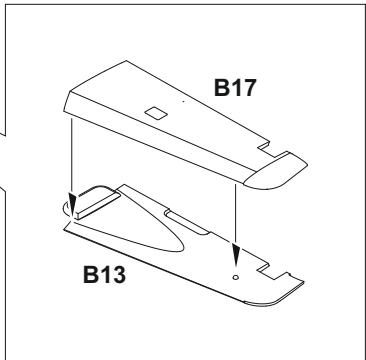
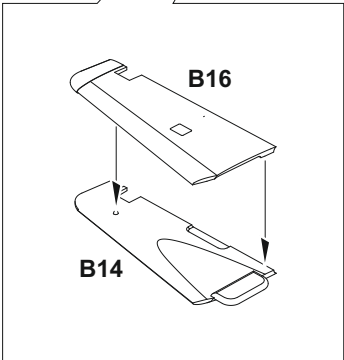

PE1, PE8 - MARKINGS **A, C, D, E, F**

PE2, PE9 - MARKING **B**

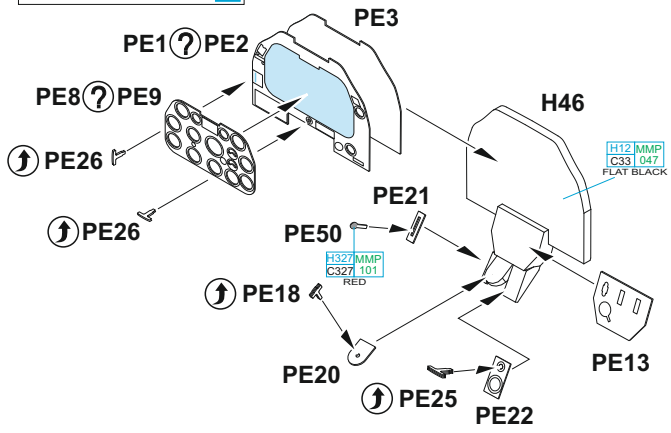

?

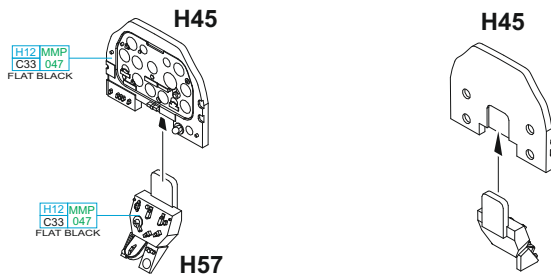

**OPTIONAL:**

decals 40, 42, 44, 46, 47 - MARKINGS **A, C, D, E, F**

decals 41, 42, 44, 46, 47 - MARKING **B**

A8 right A7 left

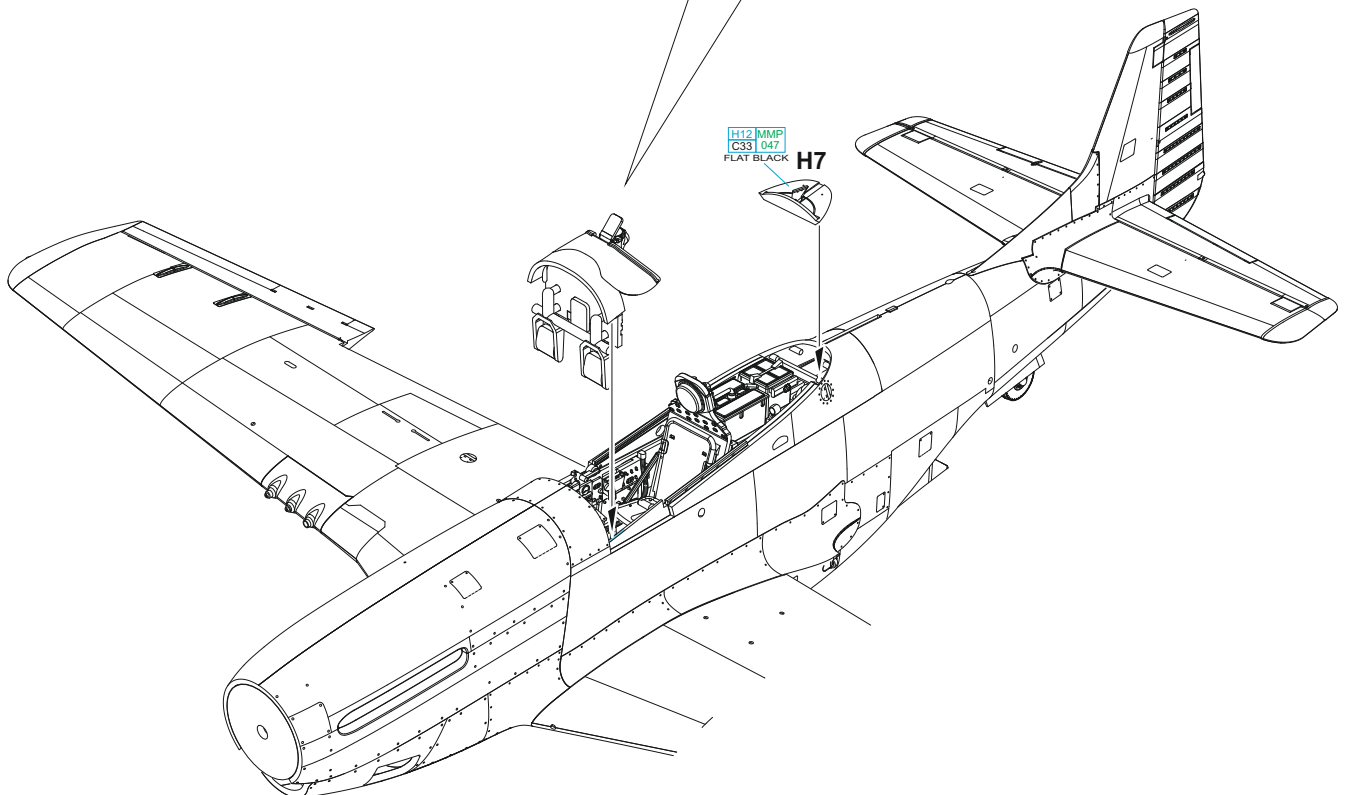
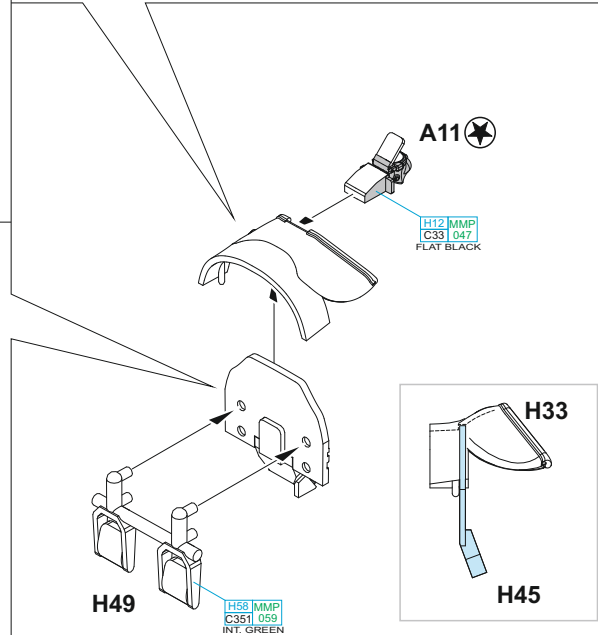
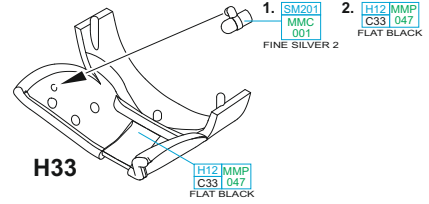

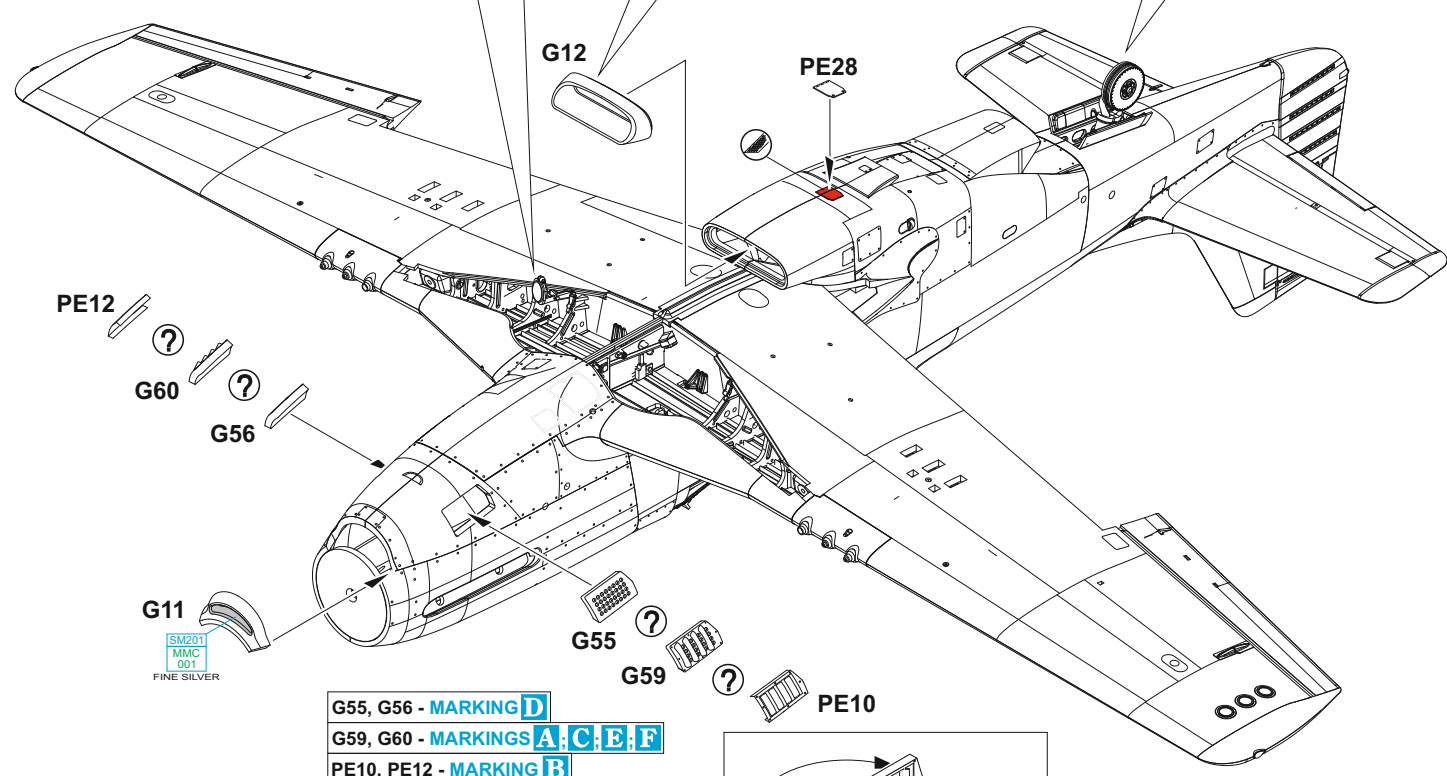
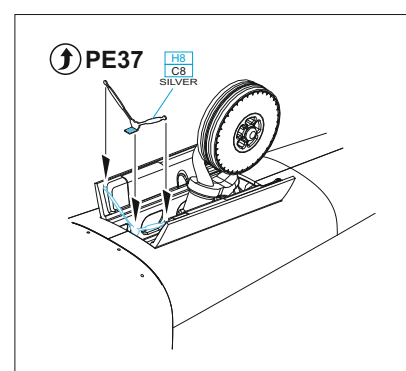
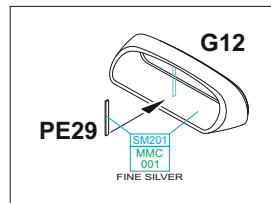
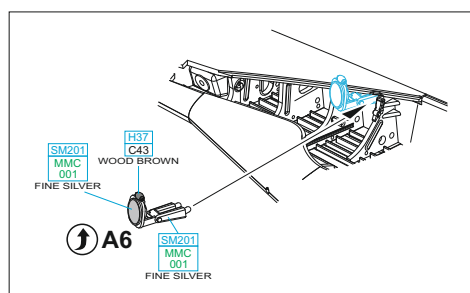
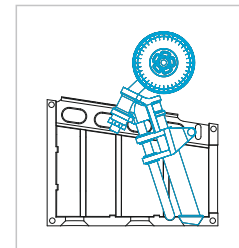
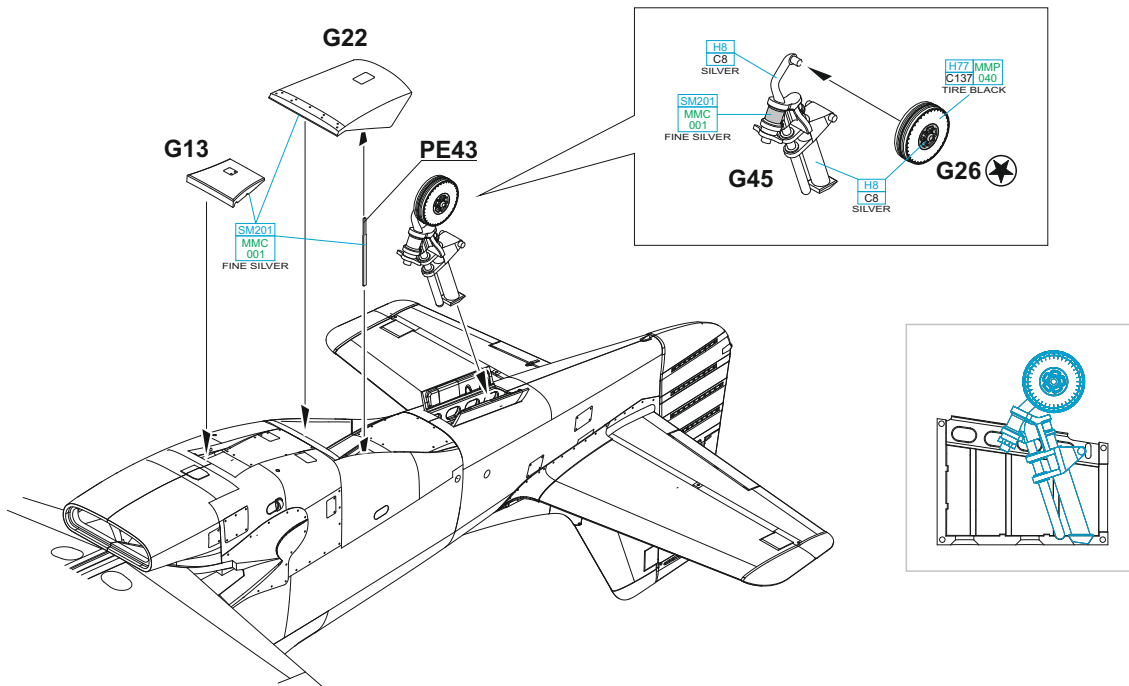

G55, G56 - MARKING **D**  
 G59, G60 - MARKINGS **A, C, E, F**  
 PE10, PE12 - MARKING **B**

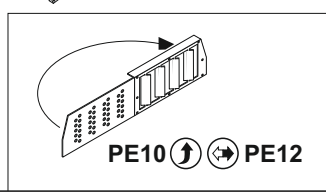



step 1 - G37, G38  
step 2 - G24, G25

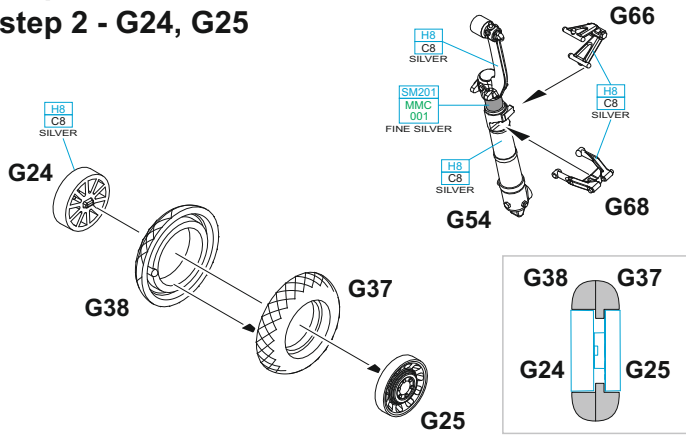

step 1 - G37, G38  
step 2 - G24, G25

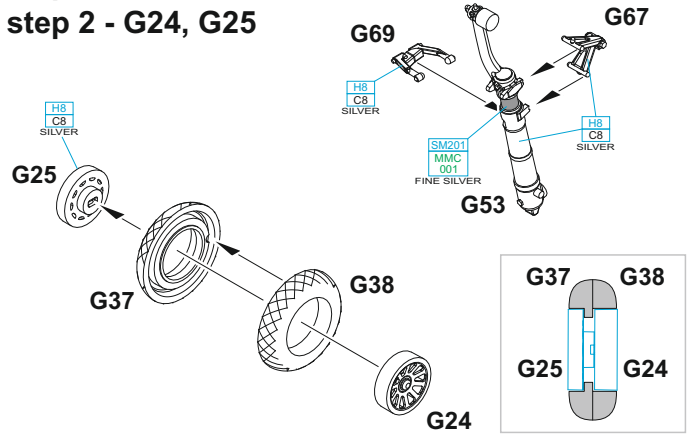

**F**

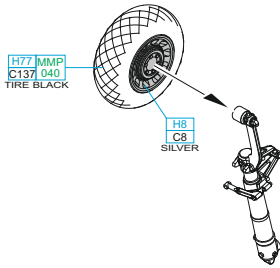

**G**

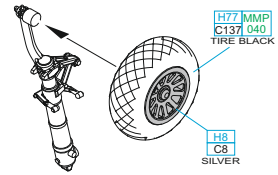

**H**

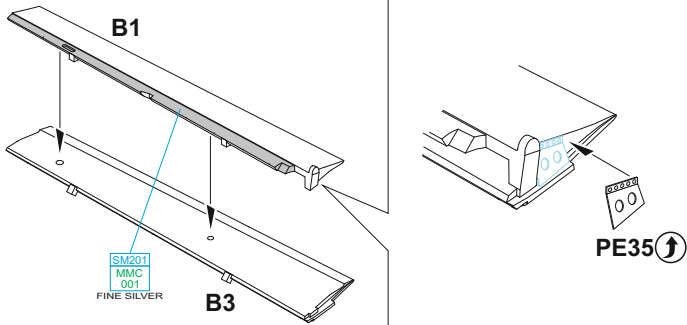

**I**

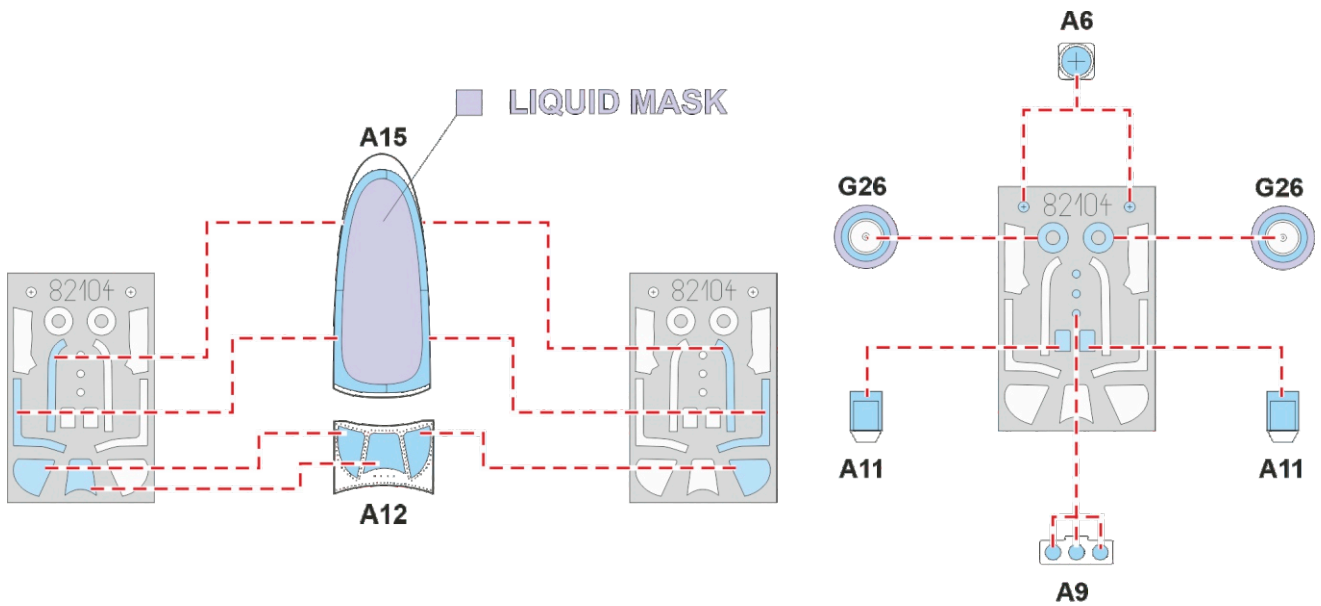
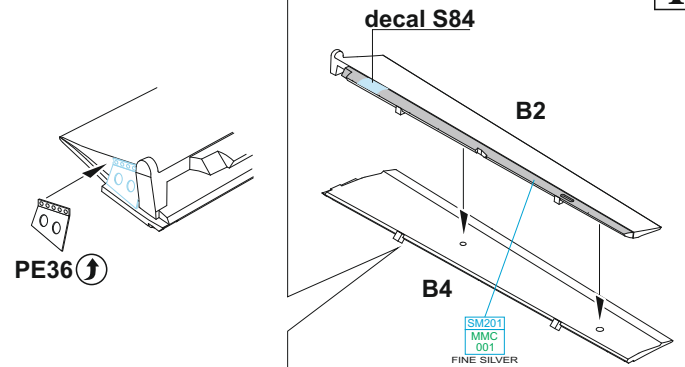

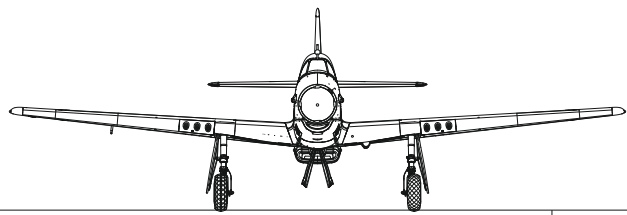
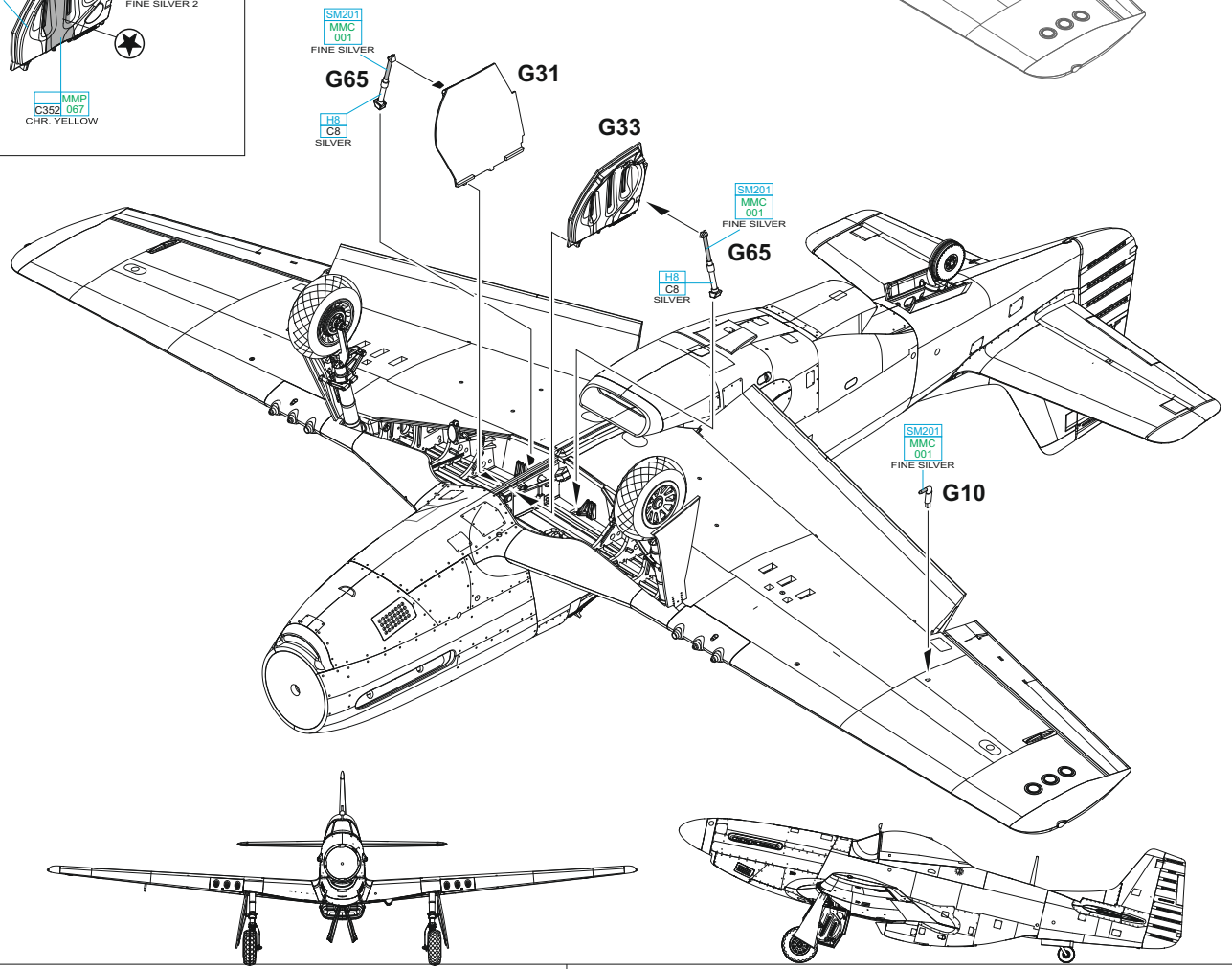
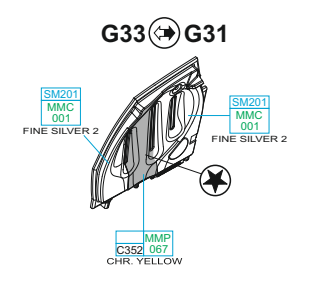
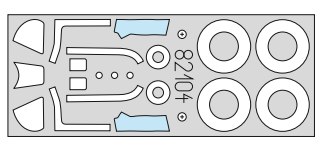
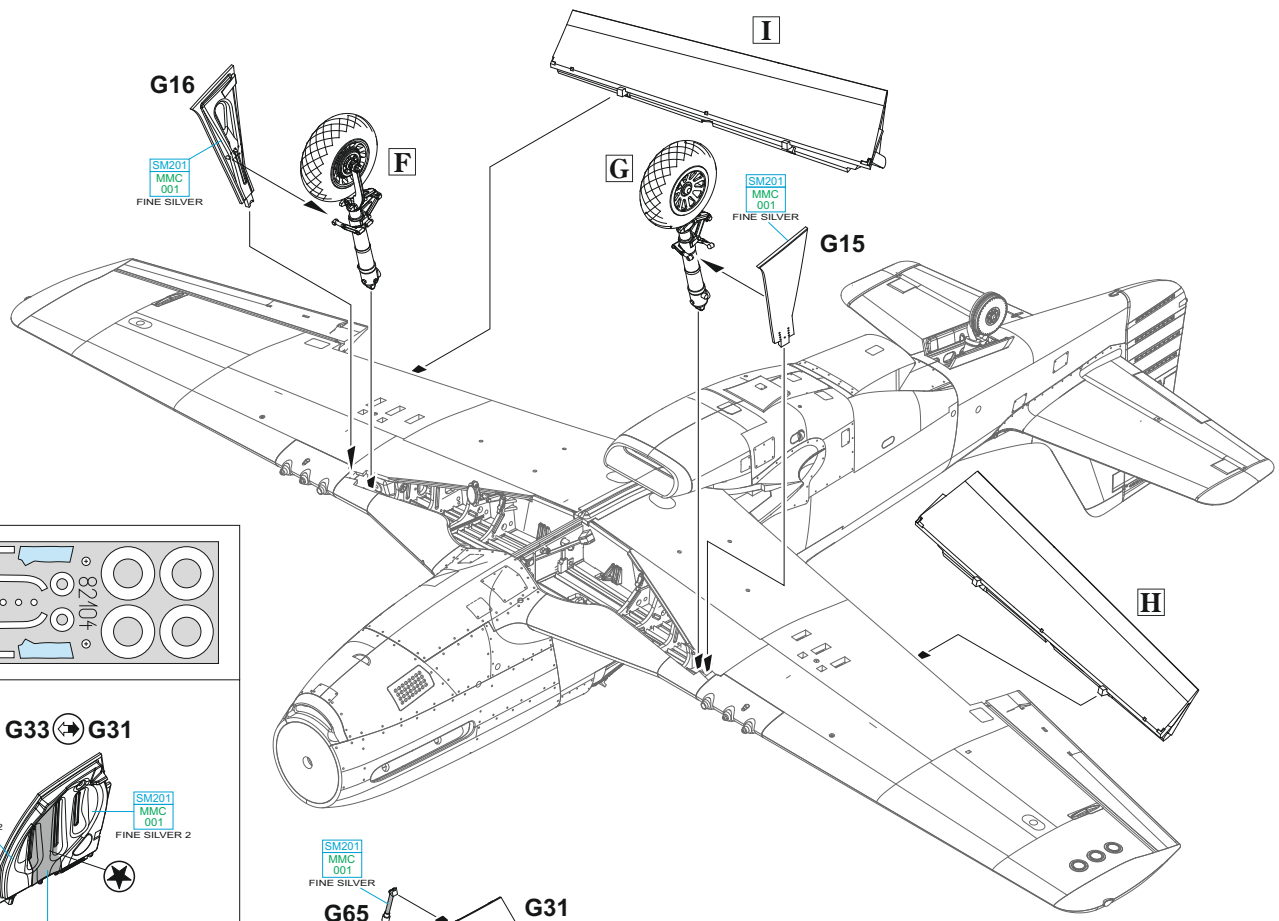

**J** MARKING **D**

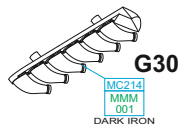

**K** MARKINGS **A, B, C, E, F**

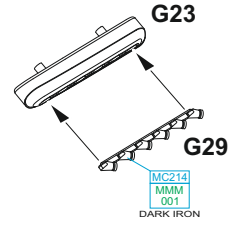
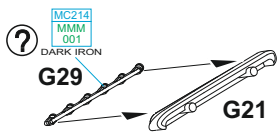

**L** MARKINGS C, F

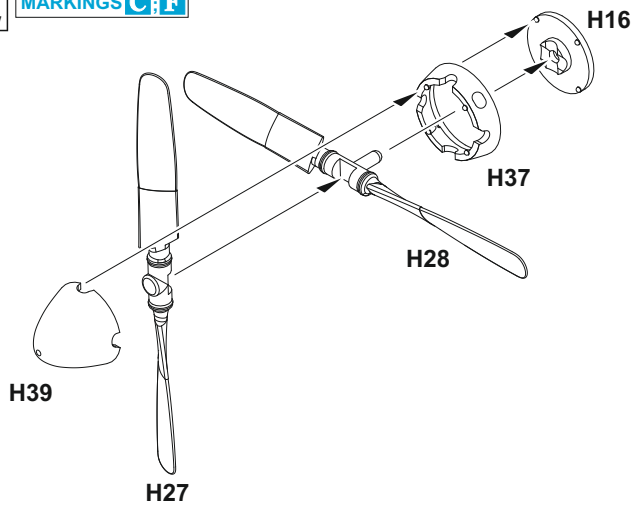

MARKINGS A, B, D, E

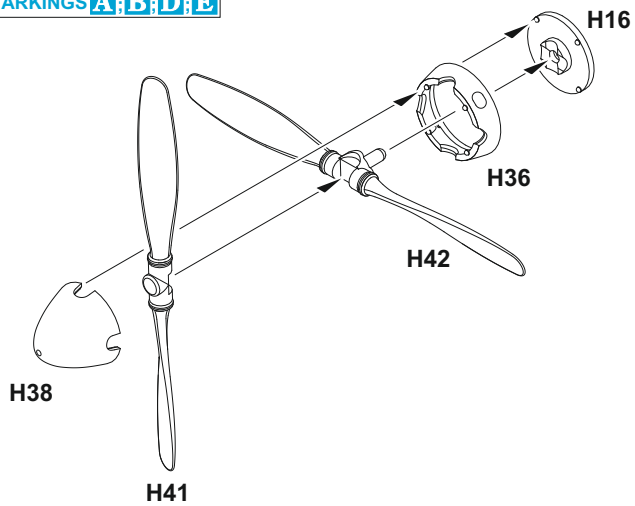

**M**

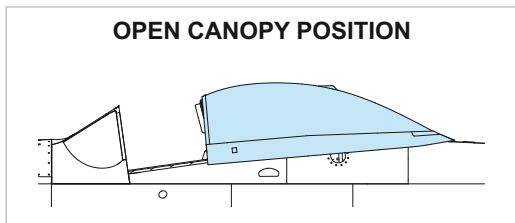
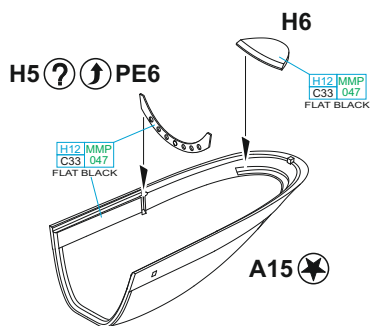

**N**

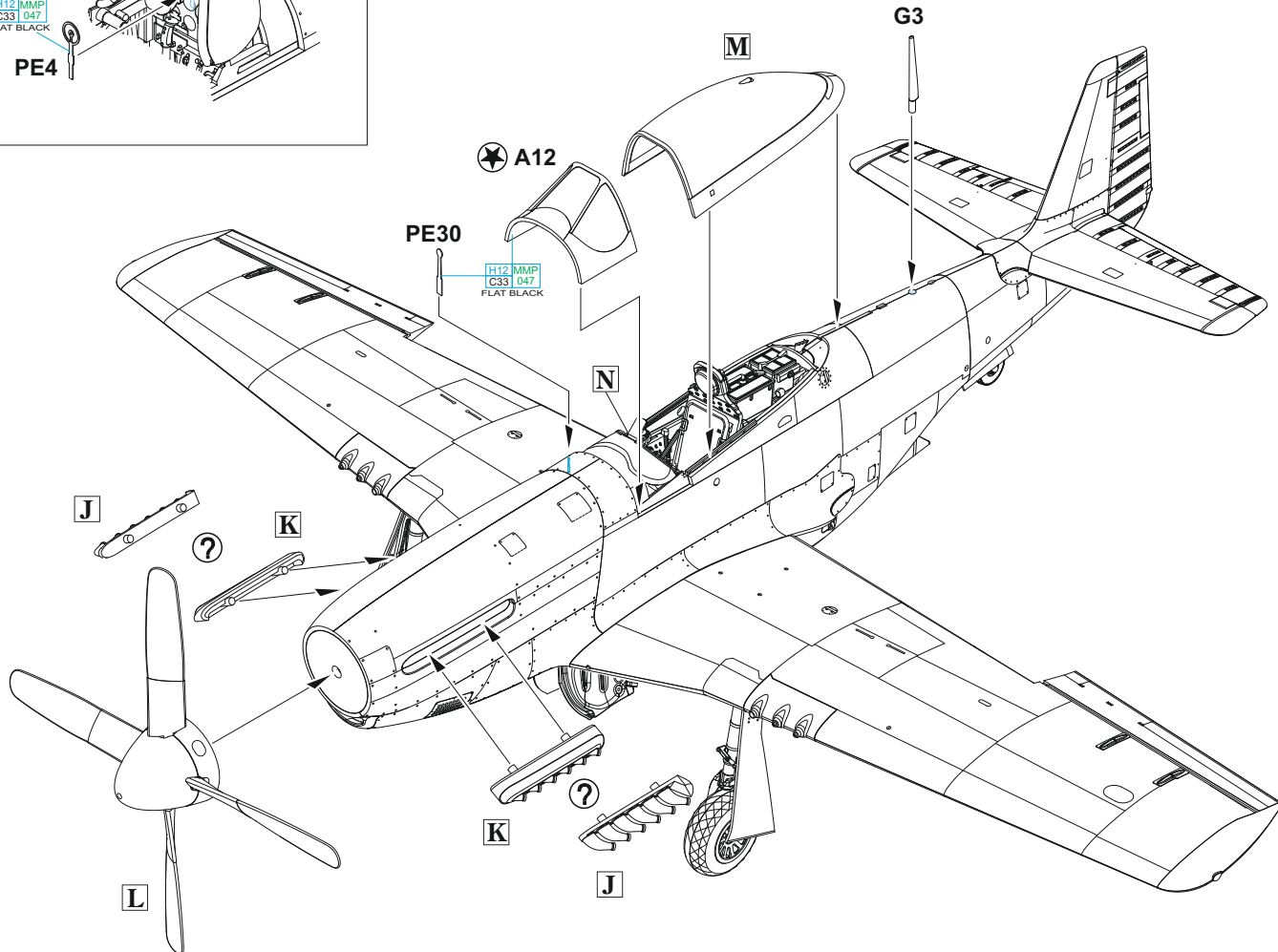
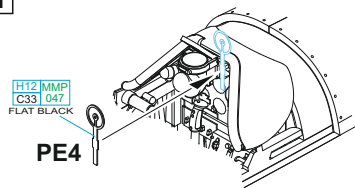

**O** 2 pcs.

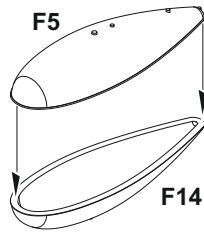
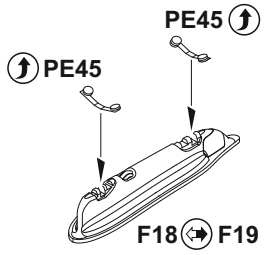

**R** 2 pcs.

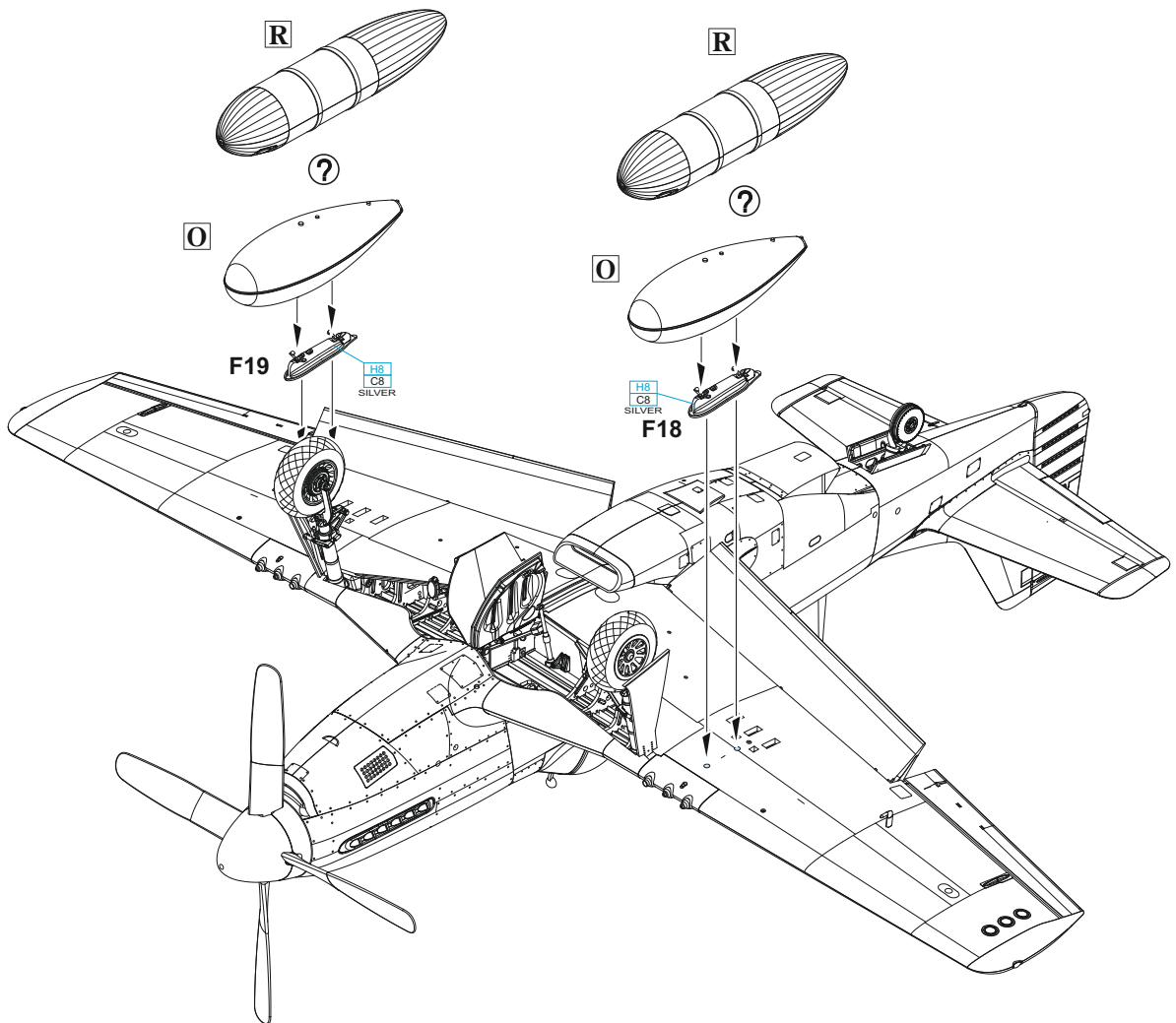
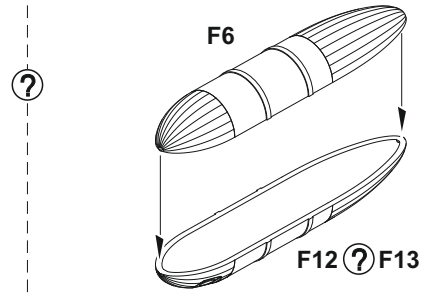



**A** Mk.IVa KH680 (P-51K-1-NT; 44-11383), P/O John Mallandaine, No. 442 Sqn RCAF, Hunsdon, England, April 1945

The "Edmonton Special" Mustang Mk.IVa, the personal mount of Edmonton-born John Mallandaine, is one of the most popular Mustang Mk.IVs. Its pilot flew it on daylight missions to Germany, protecting allied bombers. He also participated in the last operational mission of the war in the European theatre, the liberation of the Channel Islands on May 9, 1945. Post war Mallandaine continued flying as a bush pilot and he also acted as an air accident investigator. He was part of the board investigating the Martin Hartwell's crash and his subsequent cannibalism to survive. Apart of standard camouflage scheme of US colours the Mallandaine's Mustang sported the yellow anti-glare panel and canopy framing, the code in Sky colour was also outlined in yellow. The "Edmonton Special" inscription was painted on the port side only.

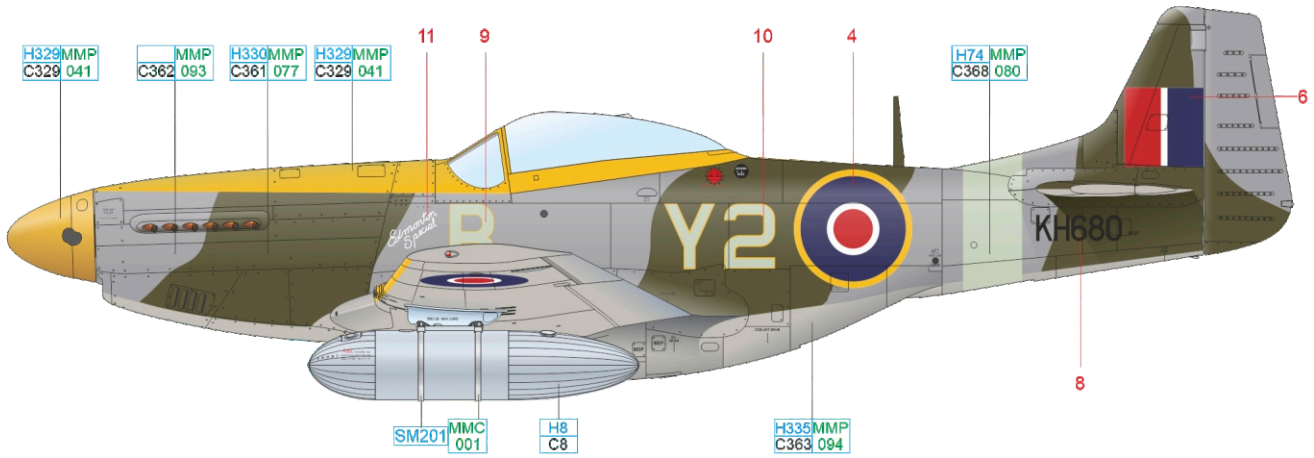

ČESKOU VERZI TEXTU NALEZNETE NA  
**www.eduard.com**  
POD KATALOGOVÝM ČÍSLEM 82104

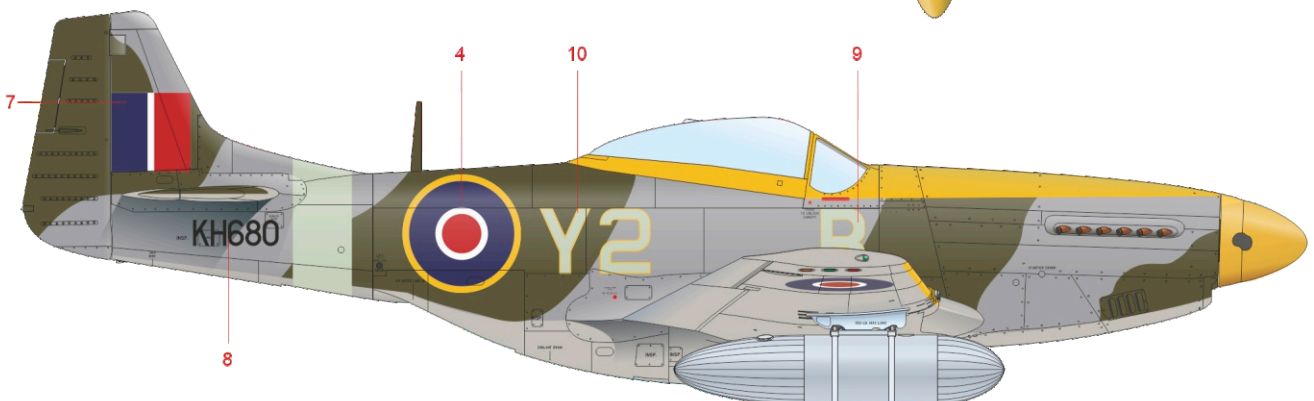
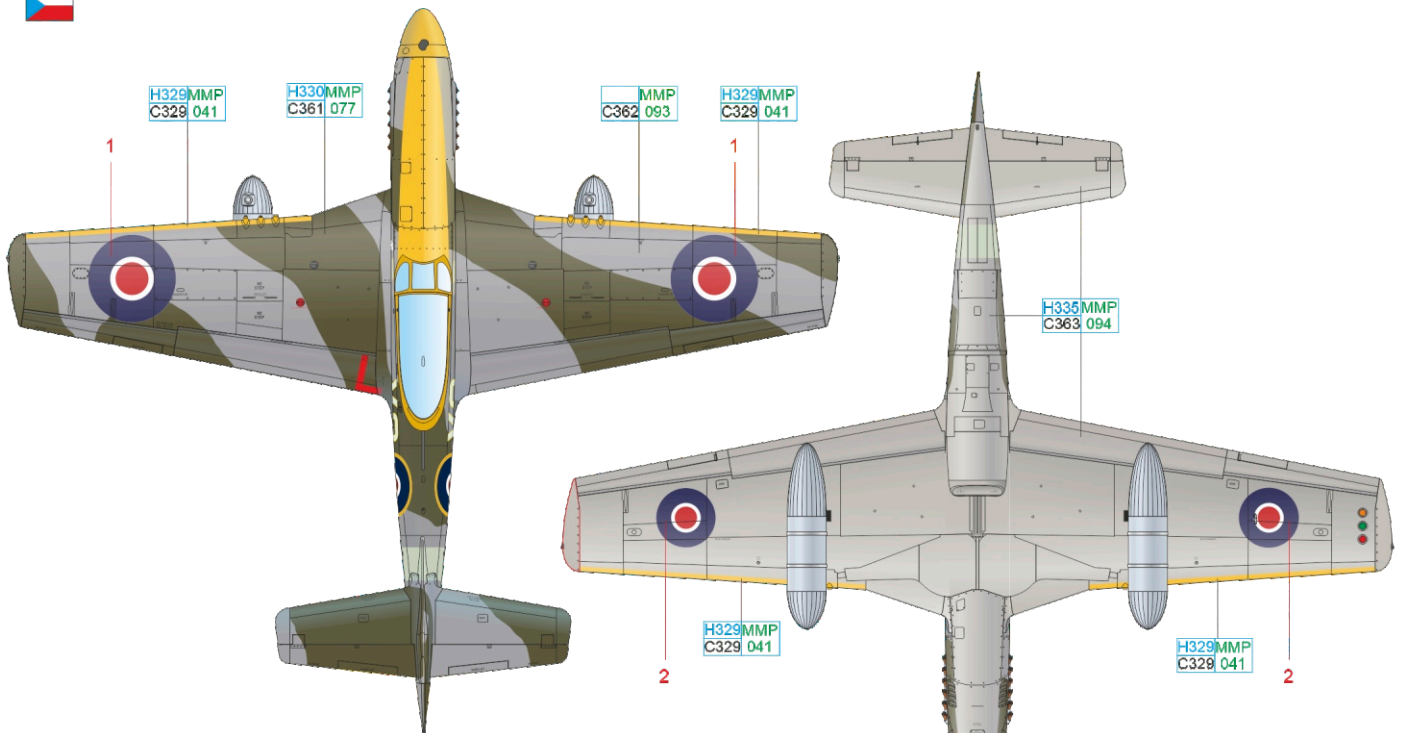

YELLOW	H329MMP C329 041	SILVER	H8 C8	SKY	H74 MMP C368 080
OLIVE DRAB	H52 MMP C12 091	NEUTRAL GRAY	H53 C13	LIGHT GRAY	H57 C73
				SUPER FINE SILVER	SM201 MMC 001

**B** Mk.IVa KM232 (P-51K-10-NT; 44-12355), W/Cdr James E. Storrar, Hunsdon Wing CO, Digby, England, April 1945

The aircraft of W/Cdr J. E. Storrar were quite easily recognizable thanks to the personal JAS code, as the fighter ace with 14 aerial victories was nicknamed. Storrar entered the RAF in 1938 and joined No. 145 Sqn in early 1940. He scored his first victories over Dunkirk and during the Battle of France, earning the DFC at the age of 19. He was transferred to No. 73 Sqn in September, 1940 and promoted Squadron Leader of No. 65 Sqn in December, 1942. In 1944 Storrar became Wing Commander and led three squadrons equipped with Mustangs. All of them were responsible for long range and attack escorts. After the War he continued his RAF career, flying the Meteor and Vampire jets. After retirement in 1957 he became a veterinary surgeon with a practice in Chester. Mustang KM232 had natural metal and silver paint finish with mid blue anti-glaze panel with dark blue outline. The JAS code was of the same colour combination but reversed.

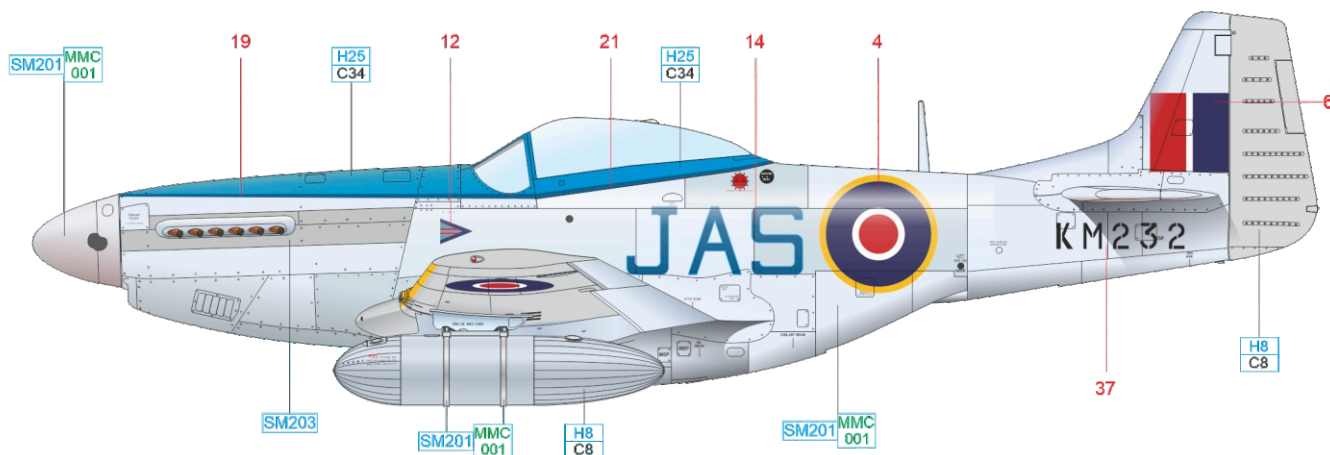

ČESKOU VERZI TEXTU NALEZNETE NA  
[www.eduard.com](http://www.eduard.com)  
 POD KATALOGOVÝM ČÍSLEM 82104

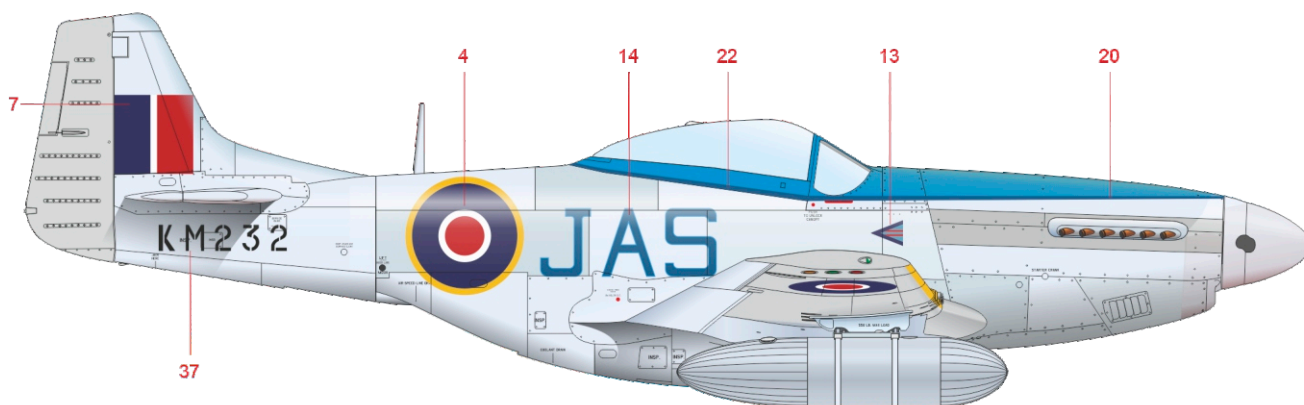
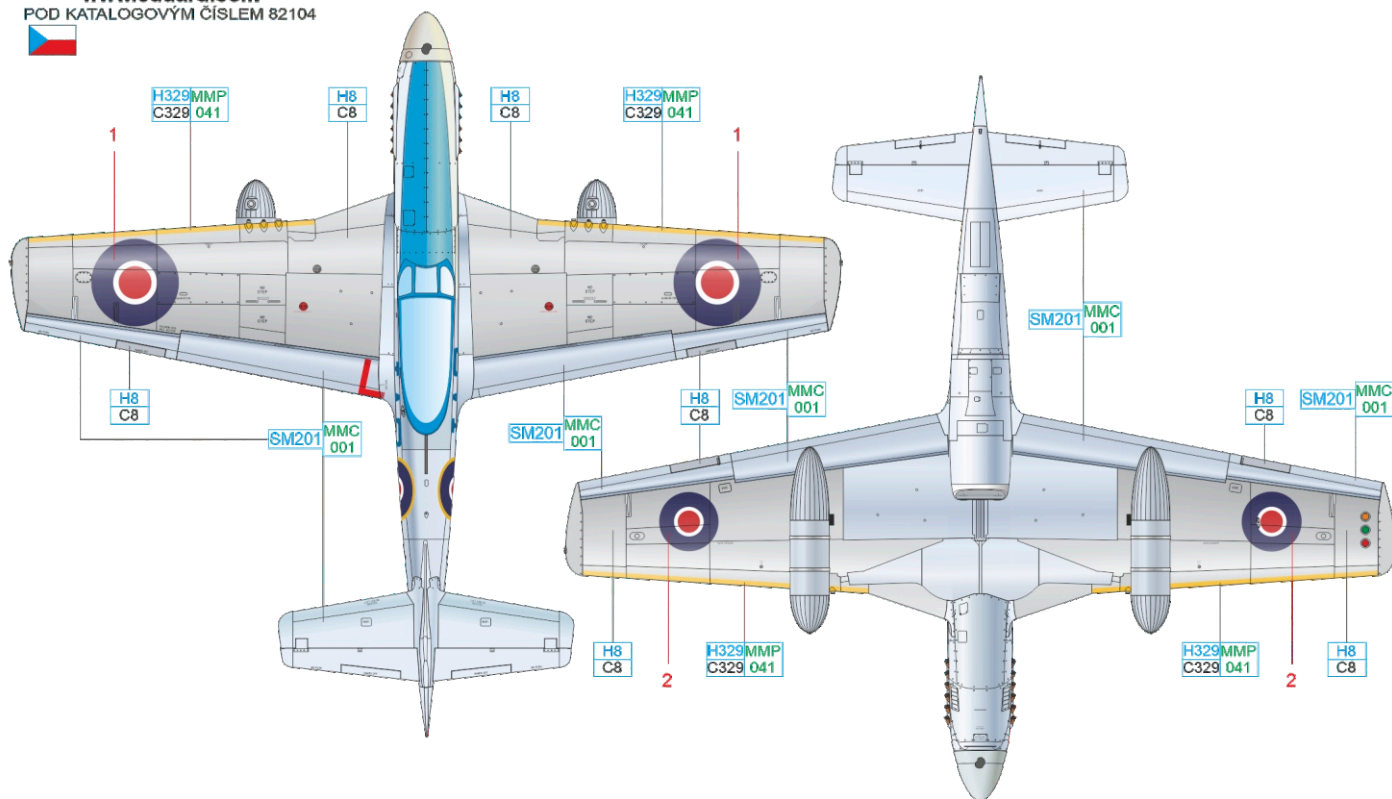

YELLOW	H329MMP C329 041	SUPER IRON	SM203	SILVER	H8 C8	SKY BLUE	H25 C34
SUPER FINE SILVER	SM201 MMC 001						

# C Mk.IV KH655 (P-51D-5-NT; 44-11182), F/O Edward R. Davies, No. 19 Sqn, Peterhead, Scotland, April 1945

No. 19 Squadron was formed on September 1, 1915, disbanded in 1919 and reformed just four years later. At the outbreak of the WWII the squadron was stationed at RAF Duxford as a part of No. 12 Group of RAF Fighter Command. Pilots of the unit, one of them was also famous Douglas Bader, helped to provide air cover over the Dunkirk beaches. The No. 19 Sqn was one of few to receive Mk.Ib Spitfires armed with the 20mm cannons and after years flying Spitfires of several marks the unit was re-equipped with Mustangs Mk.III in early 1944. They were used primarily for close air support duties. The tasking changed after the D-Day. The squadron moved to the RAF Peterhead Air Base in Scotland to provide the long-range escorts for the Coastal Command combat missions. The Squadron converted to the Mustangs Mk.IV in April 1945 there. The KH655 with code QV-P was probably flown by P/O Edward R. Davies and sported yellow and black bands around the spinner and nose.

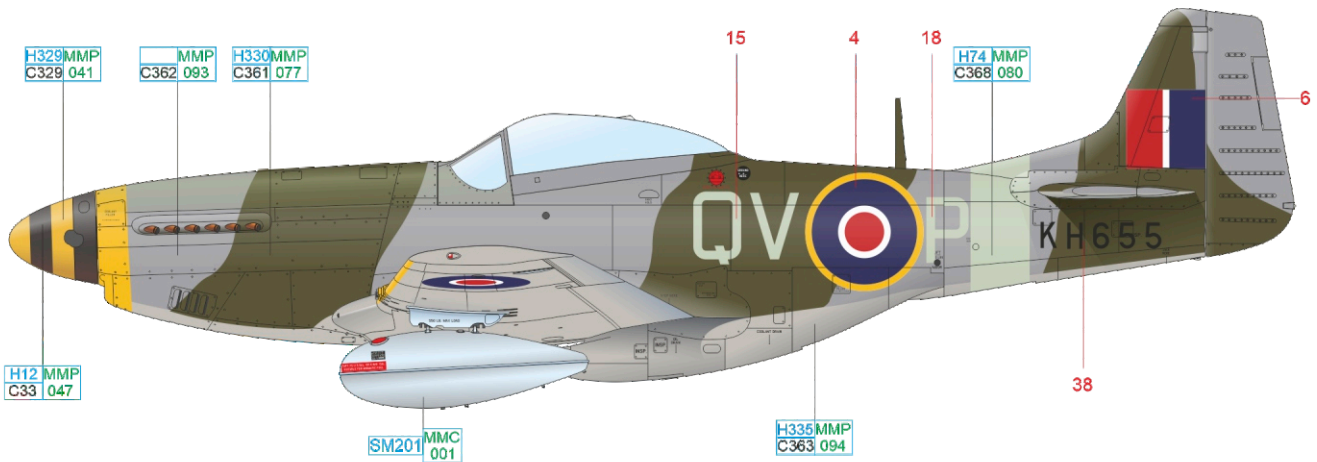

ČESKOU VERZI TEXTU NALEZNETE NA  
[www.eduard.com](http://www.eduard.com)  
 POD KATALOGOVÝM ČÍSLEM 82104

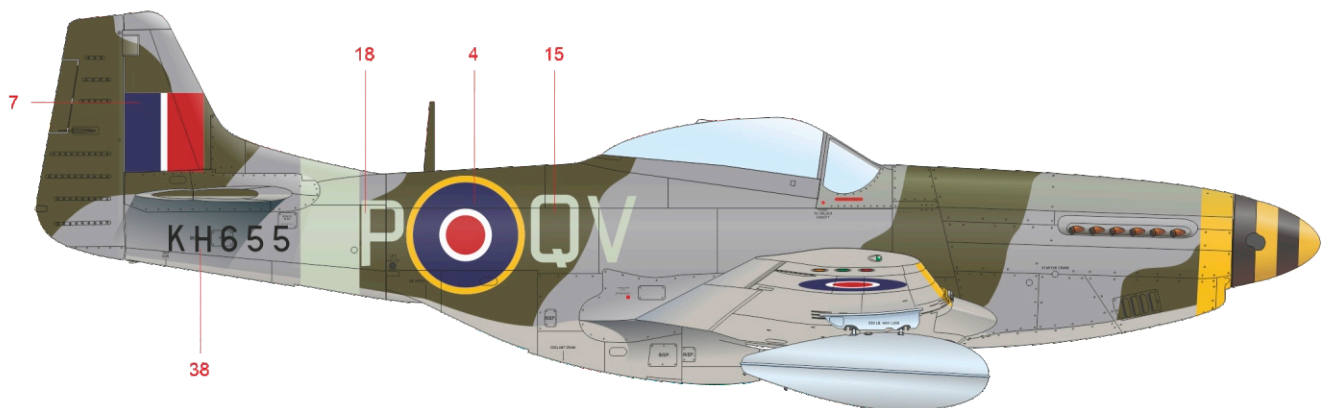
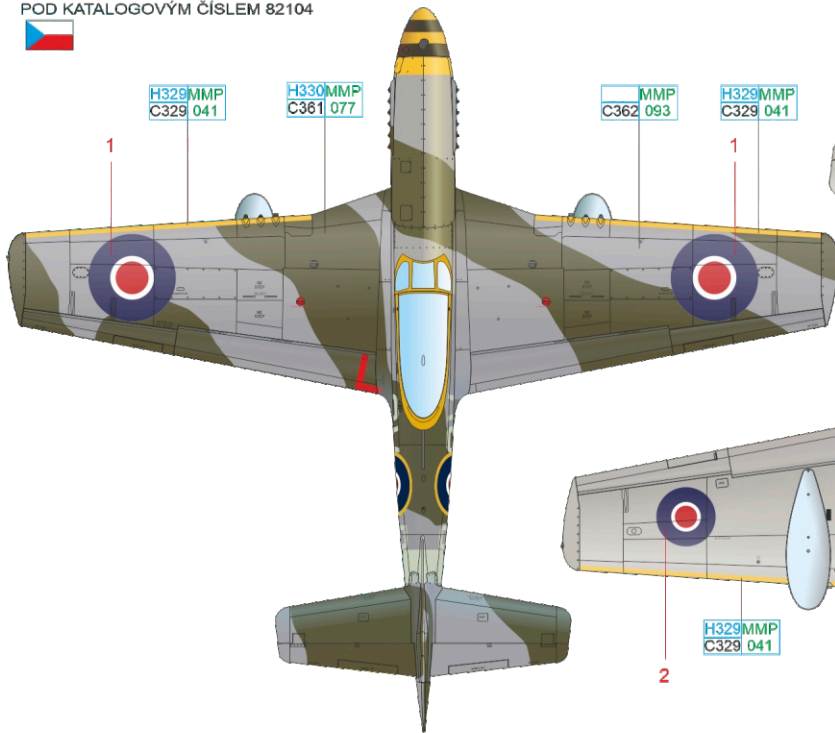

YELLOW	H329MMP C329 041	SILVER	H8 C8	SKY	H74 MMP C368 080
OLIVE DRAB	H52 MMP C12 091	NEUTRAL GRAY	H53 C13	LIGHT GRAY	H57 C73
		BLACK	H12 MMP C33 047	SUPER FINE SILVER	SM201 MMC 001



# D Mk.IVa KH716 (P-51K-1-NT, 44-11483), S/Ldr Murray P. Nash, No. 3 Sqn RAAF, Fano, Italy, January 1945

The Royal Australian Air Force No. 3 Sqn spent all its WWII combat days in the Mediterranean theatre. The Australian pilots started their combat with Gladiators, later using Hurricanes and Kittyhawks before converting to Mustangs Mk.III starting from November 13, 1944. The first Mustang Mk.IVa arrived on November 26, 1944 (KH677) and was assigned to S/Ldr Murray Nash who changed it on December 12 for the KH716. He used this one until he was sent for a Fighter Leader course in March 1945. The following month the KH716 was lost. The aircraft was left in natural metal finish, with the wing filled and sanded area painted silver as well as the control surfaces with the fabric cover. The KH716 aircraft had unusually placed serial, partly overpainted by the code letter. The P letter was probably repainted or repaired, getting slightly different shape at some time.

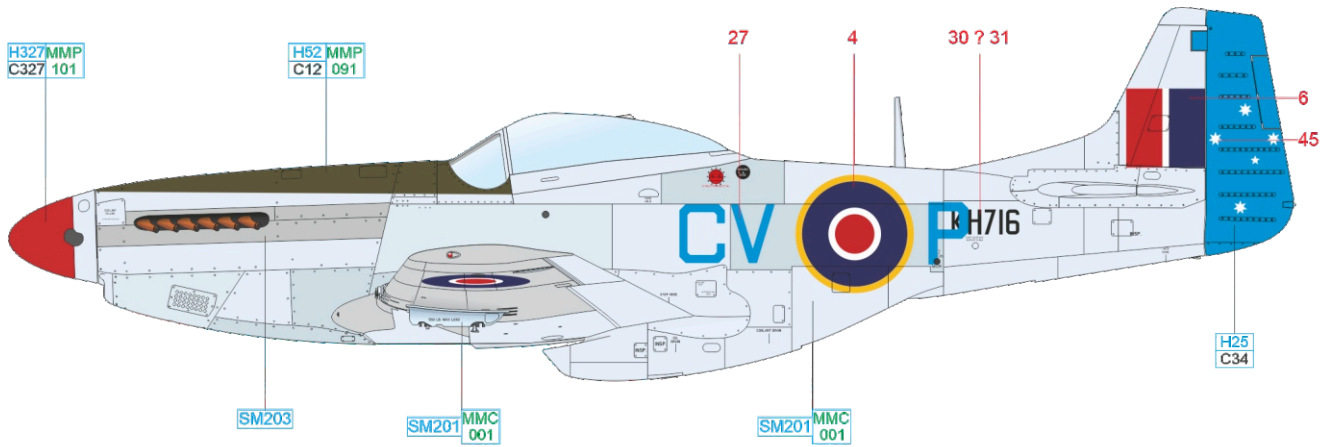

ČESKOU VERZI TEXTU NALEZNETE NA  
[www.eduard.com](http://www.eduard.com)  
 POD KATALOGOVÝM ČÍSLEM 82104

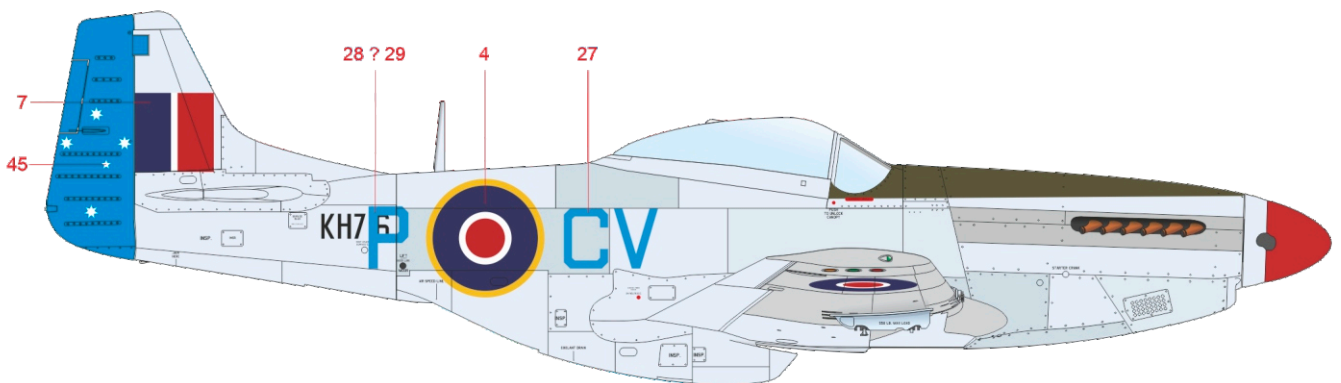
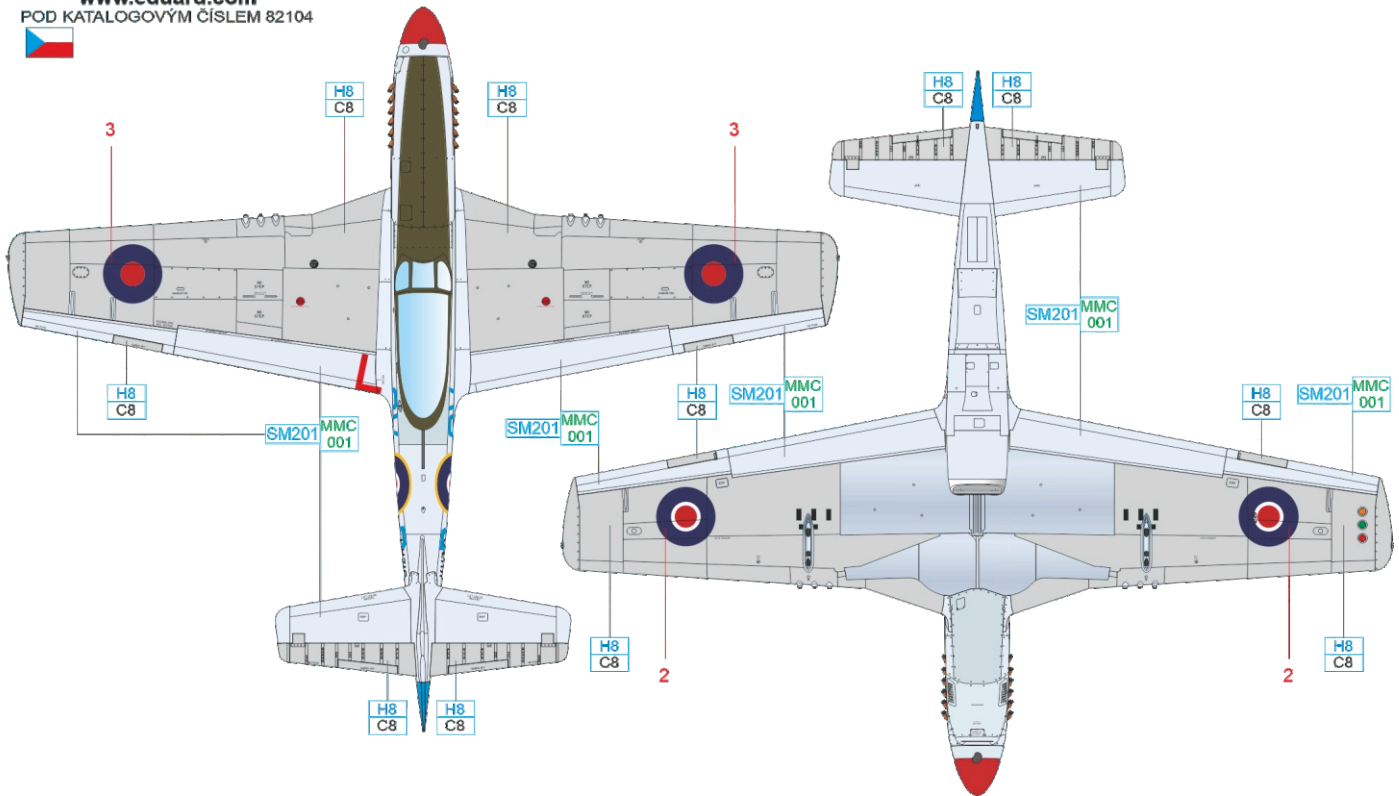

RED	H327 MMP C327 101	OLIVE DRAB	H52 MMP C12 091
SUPER FINE SILVER	SM201 MMC 001	SUPER IRON	SM203
SILVER	H8 C8	SKY BLUE	H25 C34



# E Mk.IVa KH852 (P-51K-5-NT; 44-11840), No. 112 Sqn, Cervia, Italy, April 1945

After disbanded in 1919 after the Great War, the squadron was re-formed on May 16, 1939 on board of the aircraft carrier HMS Argus enroute to its destination in Egypt. The pilots had to wait for their first aircraft, obsolete Gloster Gladiators, until June, but during July 1941, the squadron was one of the first in the world to become operational with the P-40 Tomahawk. The sharp nose with the large radiator inlet inspired the personnel to paint their distinctive feature – the shark mouth, which gave the unit its nickname „Shark Squadron”. The unit changed Tomahawks for P-40 Kittyhawks later and kept them during its Africa campaign and even after it moved to the Sicily in July, and onto the Italian mainland in September 1943. Juna 1944 was the end of Kittyhawks at the squadron, as they were replaced by the Mustangs Mk.III and, starting from February 1945, Mustangs Mk.IV arrived. The squadron remained in Italy as part of the occupying forces, until its disbandment on December 30, 1946. The KH852 was natural metal and silver paint finished aircraft with typical shark mouth.

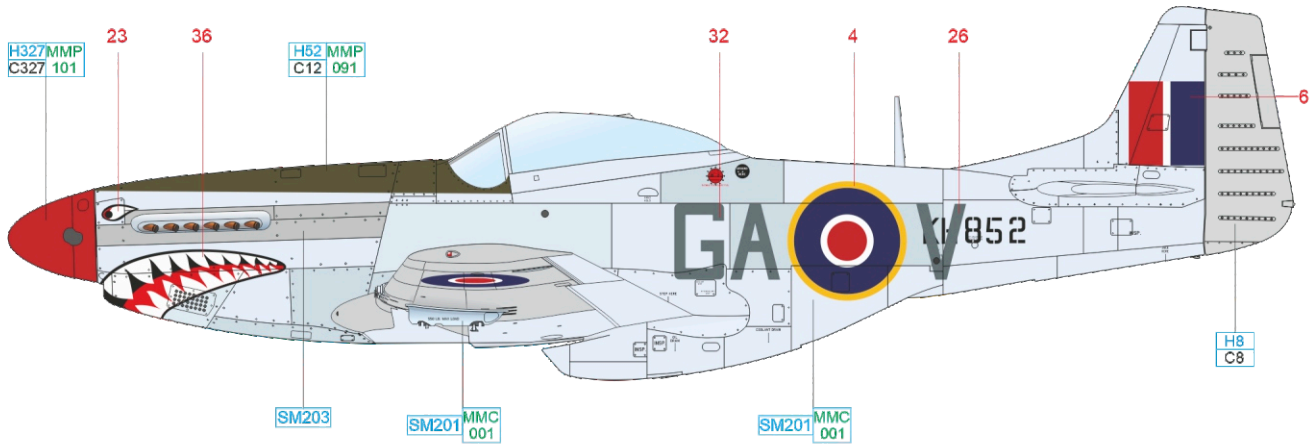

ČESKOU VERZI TEXTU NALEZNETE NA  
[www.eduard.com](http://www.eduard.com)  
 POD KATALOGOVÝM ČÍSLEM 82104

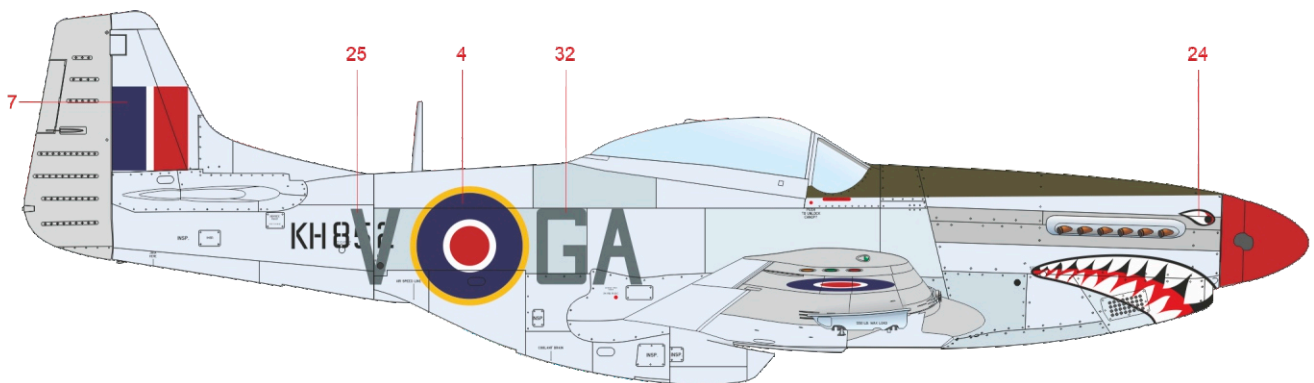
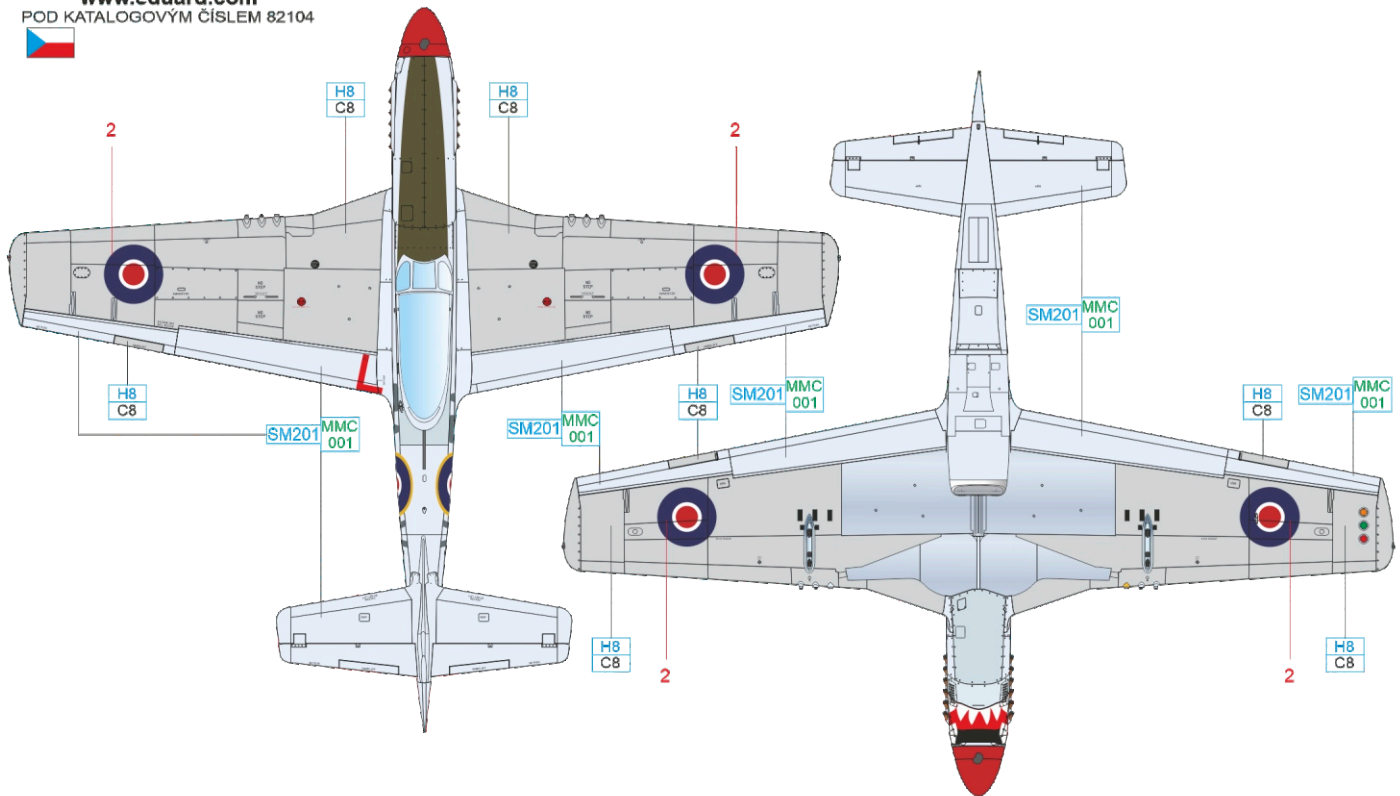

RED	H327 MMP C327 101	OLIVE DRAB	H52 MMP C12 091
SUPER FINE SILVER	SM201 MMC 001	SUPER IRON	SM203
		SILVER	H8 C8

# F Mk.IV KH663 (P-51D-5-NT, 44-11255), No. 303 (Polish) Sqn, Wick, England, December 1945

The famous No. 303 Sqn earned its reputation during the Battle of Britain flying the Hawker Hurricanes, later used several marks of Spitfires for both aerial combat as well as strafing. It was the most effective of all the Polish squadrons with 297 aircraft destroyed during 9,900 combat sorties, not to mention ground targets destroyed. Poles started to re-equip with Mustang Mk.IVs at the beginning of April 1945 and so the pilots only flew them in combat for less than a month as they flew their last mission on April 25, 1945. The unit was disbanded in December 1946. The KH663 had the British camouflage upper surfaces scheme of Dark Green and Sea Grey colours. There was a non-standard roundel painted on the fuselage, bigger also in diameter than usually used C1 type. The canopy was changed from another aircraft in natural metal finish. The aircraft sported the Polish national insignia on both sides of the nose as well as the unit badge under the canopy.

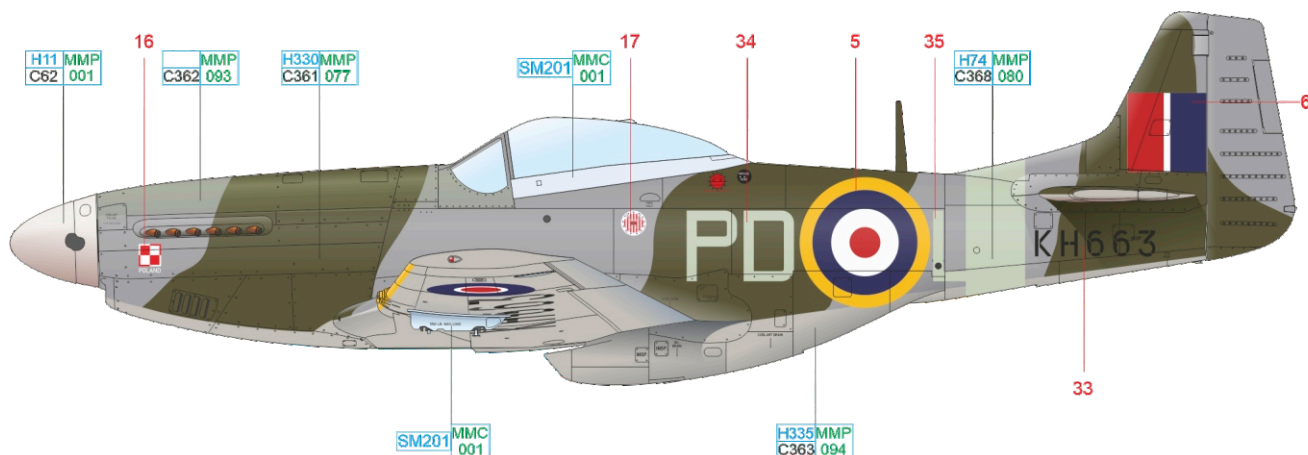

ČESKOU VERZI TEXTU NALEZNETE NA  
[www.eduard.com](http://www.eduard.com)  
 POD KATALOGOVÝM ČÍSLEM 82104

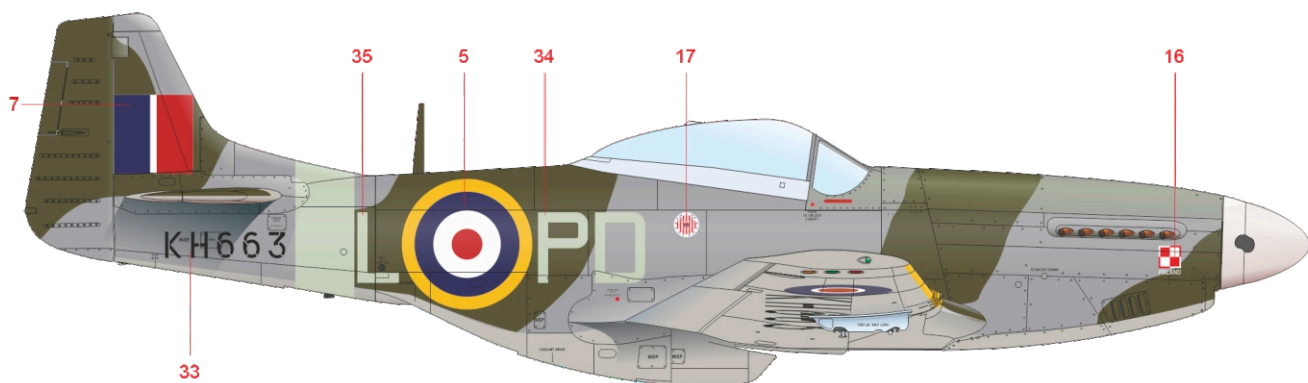
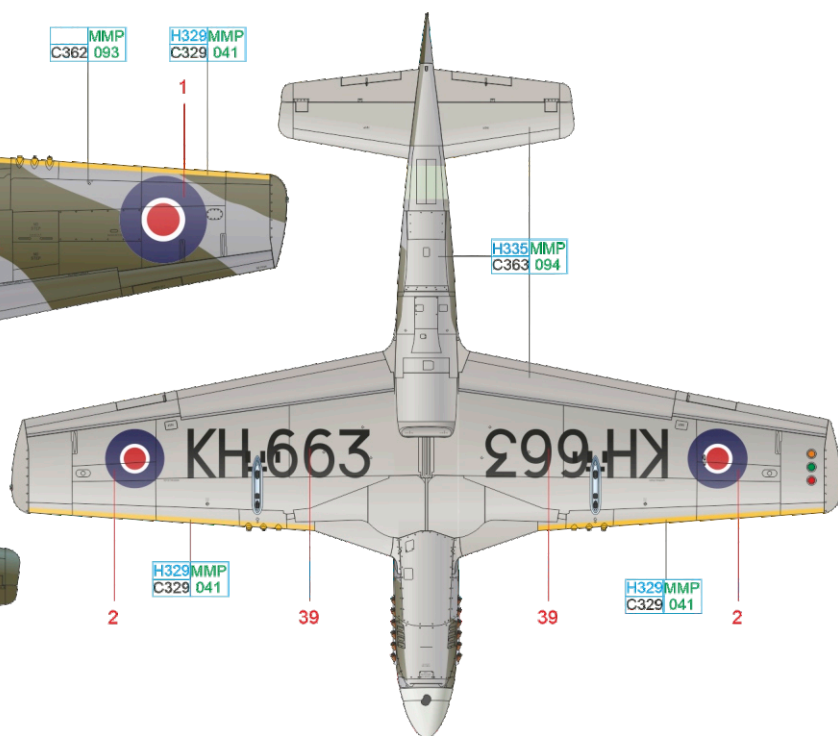
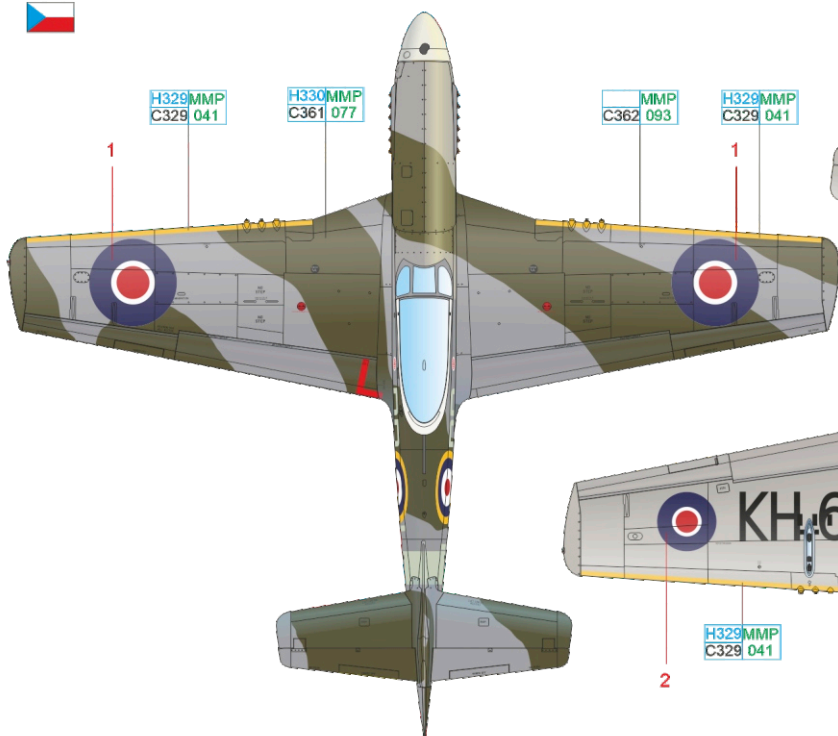

WHITE	H11 MMP C62 001	SKY	H74 MMP C368 080
DARK GREEN	H330 MMP C361 077	OCEAN GRAY	MMP C362 093
MEDIUM SEA GRAY	H335 MMP C363 094	SUPER FINE SILVER	SM201 MMC 001

# Mustang Mk.IV ALUMINIUM LACQUER PAINTED AREAS

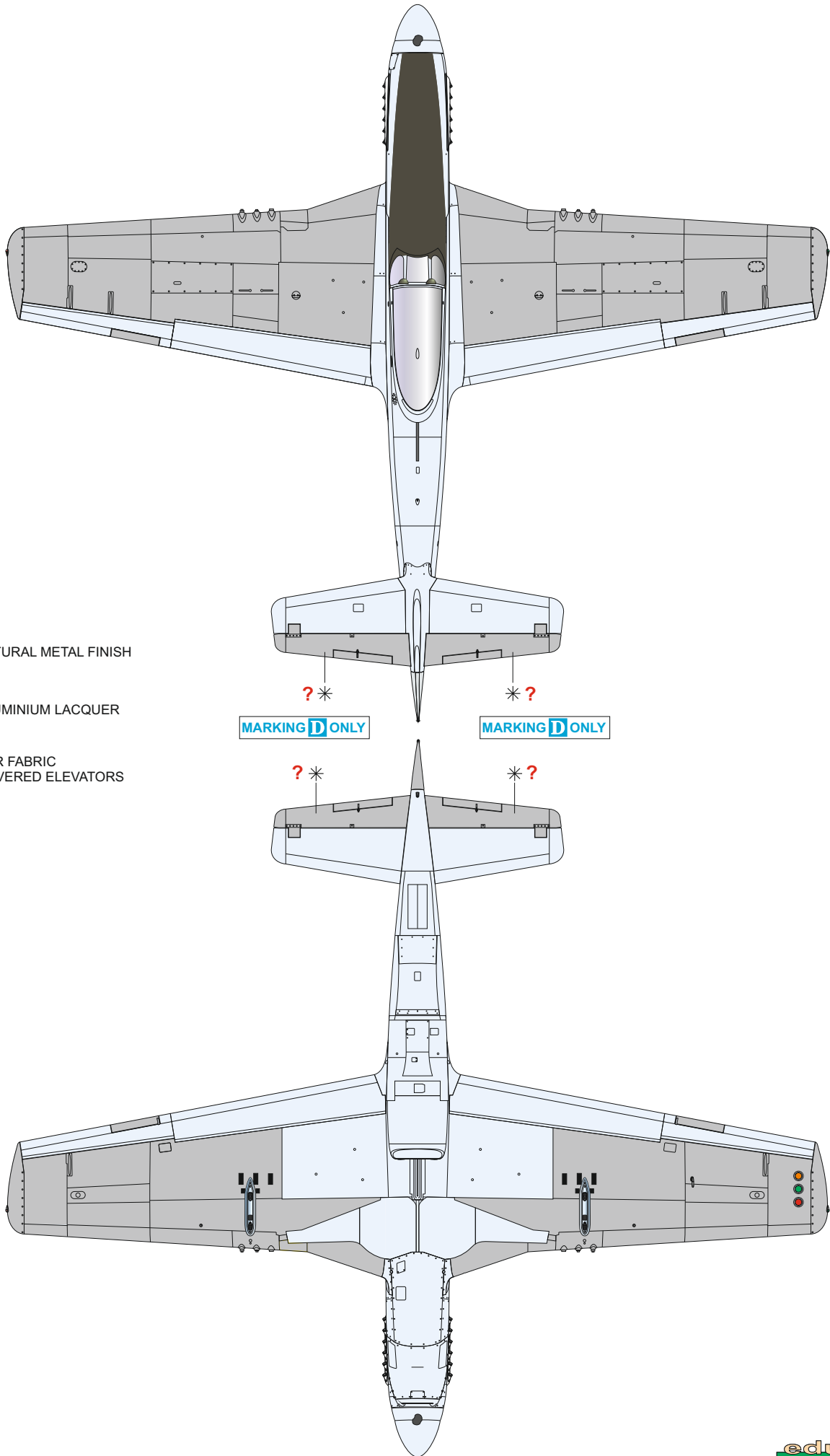

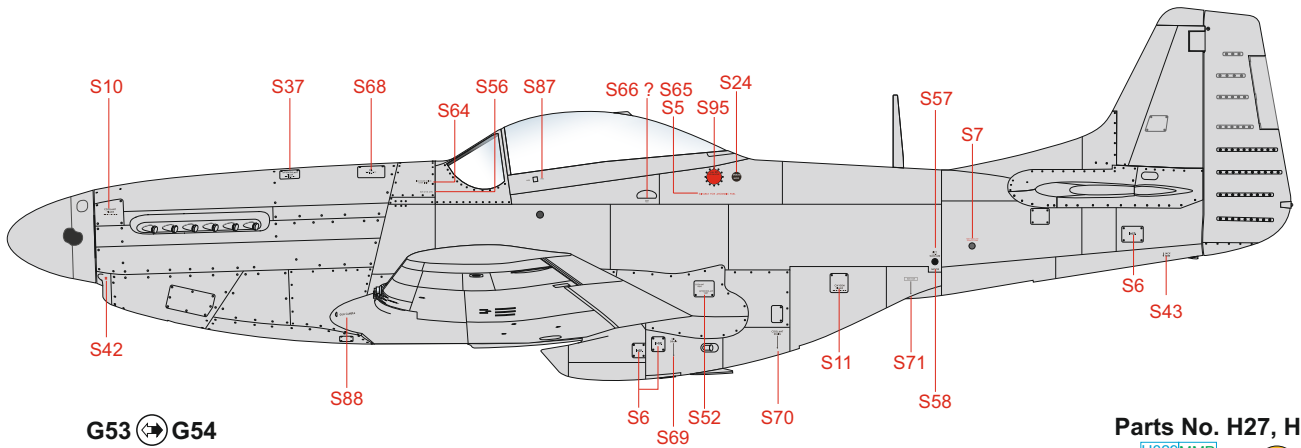

G53 G54

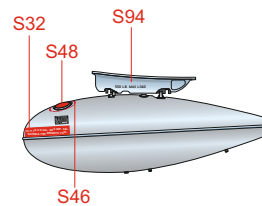
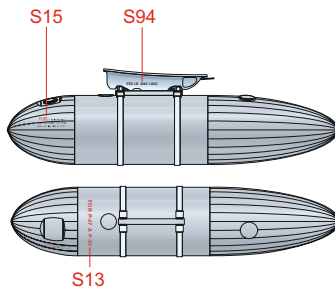
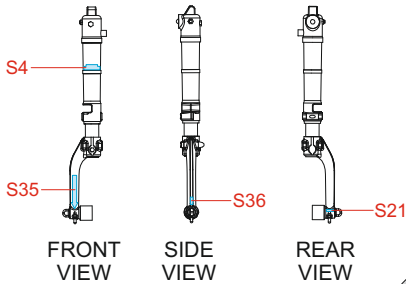

Parts No. H27, H28

H329MMP  
C329 041  
H12 MMP  
C33 047

S76  
S27 ?  
S31



Parts No. H41, H42

H329MMP  
C329 041  
H12 MMP  
C33 047

S67  
S89, S90,  
S91, S92

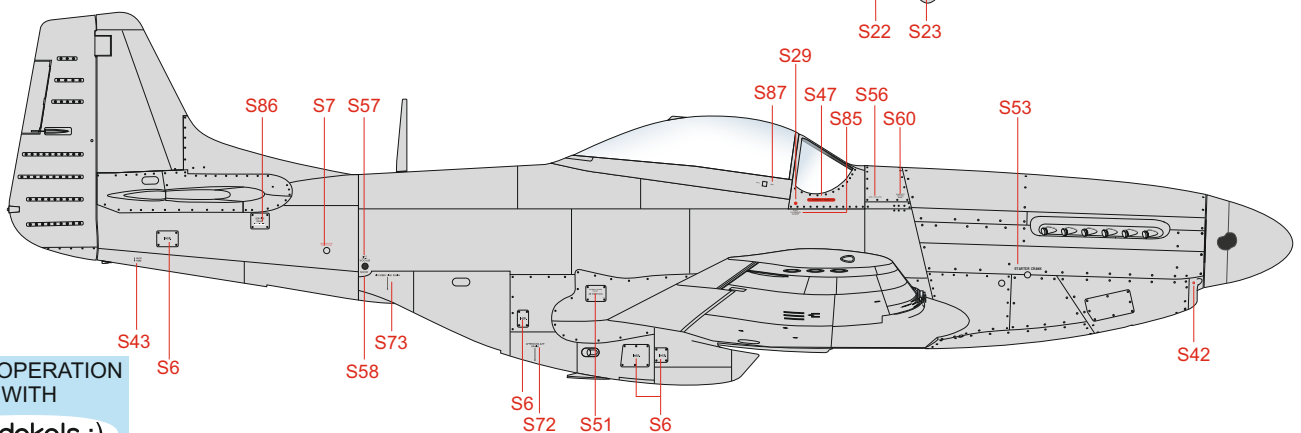
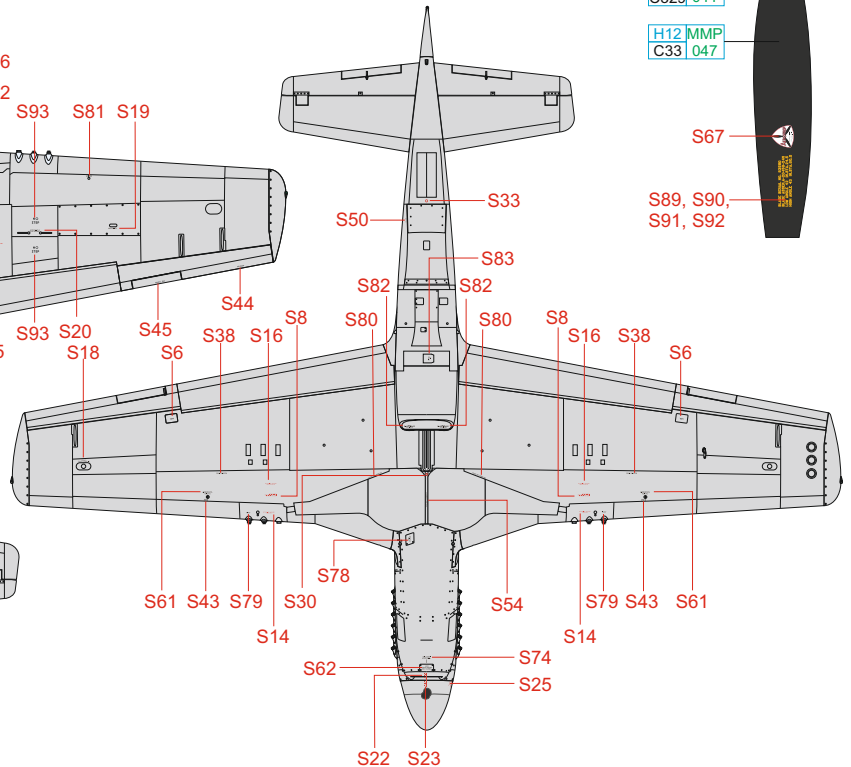
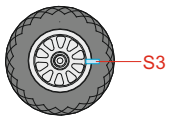
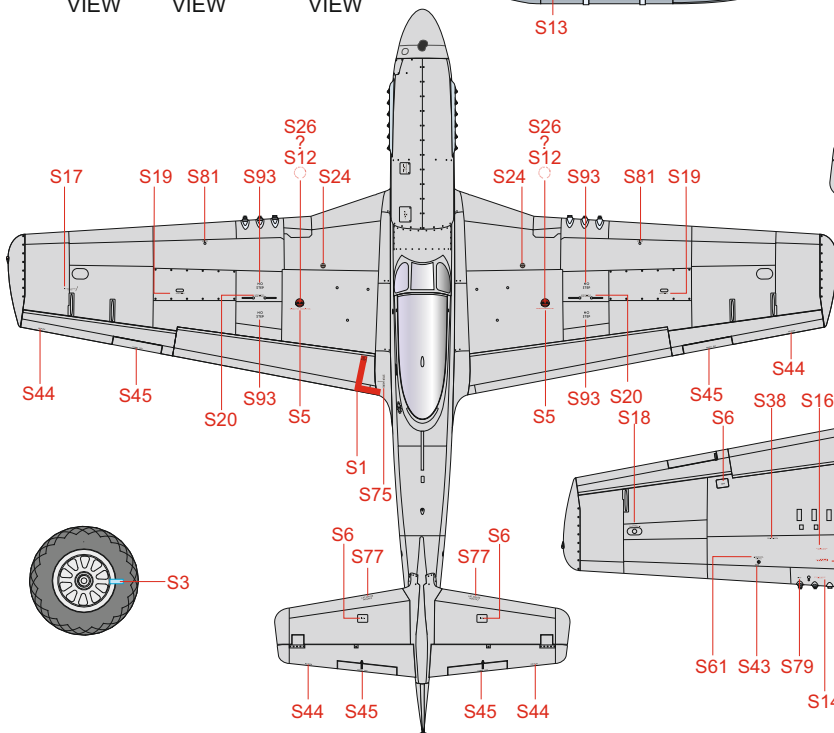

IN COOPERATION  
WITH  
fündekals :)

eduard