

eduard



DU DOCH NICHT!!

1/72

INSTRUCTION SHEET

LIMITED EDITION

2135-NAV1



foto: via Jörn Leckscheid

text: Jörn Leckscheid & Vladimír Šulc

The highest scoring surviving German ace of the Great War, recipient of the Pour le Mérite order, winner in 62 aerial combats, remarkable pilot, party man and playboy... Ernst Udet was all of this and also the man who was unable to bear the burden of the war he was fighting from the office and behind the scenes instead of the cockpit of his pursuit aircraft.

Ernst Udet was born in Frankfurt am Main on Sunday, April 26, 1896 as the son of Adolf and Paula Udet (née Krüger). The family moved to Munich when Ernst was still a little boy, and he would grow up in the capitol of Bavaria. Erni, as he was known to his friends, as a bit of a tomboy, and while not being the most ardent student, he was described as being a bright child who learns quickly – but forgets just as easily!

Too short to serve

He very much enjoyed playing outside with his friends and had developed remarkable skills with his self-made slingshot. Needless to say that these childhood marksmanship skills would serve him well a few years later. He developed an interest in aviation at an early age, and, together with a group of friends, founded the „Aero Club München“ sometime between the age of ten to thirteen.

Beginning in 1909, the Oberwiesenfeld in-Munich was used as an airfield, and Gustav Otto, the son of the inventor of the Otto engine, set up his company „Gustav Otto Flugmaschinenwerke“ near that location. Erni and his friends would visit the area frequently to watch the aeroplanes and balloons, but his dream of learning to fly could not be fulfilled while he was still attending school. His performance in school did not improve much over the years, but he was very skilled at drawing, and when he did pass his exams in 1913, his delighted father presented him with a motor-bike. At the outbreak of the war, Udet immediately volunteered, but was turned down since he was not even 1,60 m tall. But he still found a way to make it to the front about two weeks later by taking a clever detour. The „ADAC“, the German Automobile Association, had been looking for volunteers who owned a motorcycle and were willing to take it along to the front. They did not care about the

Udet standing by his most famous and most enigmatic aircraft, Fokker D.VII (OAW) with the „Du doch nicht!!“ inscription on the horizontal tail. It is less known fact, that this famous and often published photograph was heavily retouched. The struts, for example, were painted to the photo by pencil, and the top wing stripes are also painted by skilled retoucher except the first strip on the right wingtip.



foto: Ullstein bild via Fotobanka ČTK

Erni at the age of thirteen in his homemade glider in Munich - Oberwiesenfeld, 1909.

height of a volunteer, and so Erni and his motorbike left Munich on the evening of August 18, 1914. His career as a motorbike messenger would be rather short, because when he learned that he could get into military aviation quicker if he possessed a privately acquired pilot's licence, he took up flying lessons at the aforementioned Gustav Otto Werke at the end of 1914 and received his civilian pilot licence in April 1915.

Winning his spurs

From then on, his pilot career progressed like that of many other men. He served with various two-seater units (Fliegerabteilungen), and one of these was later reformed into Kampfeinsatz-Kommando (KEK) Habsheim. With that unit Udet scored his first aerial victory in the afternoon of March 18, 1916, downing a French Farman F 40, which was one of 22 planes heading to bomb Mülhausen on that day.

By the autumn of 1916, another reorganization in the Fliegertruppe began to take shape, and the first Jagdstaffeln (Jastas) had been formed. KEK Habsheim transformed into Jasta 15, with Udet formally transferred to that unit on October 8, 1916 without moving anywhere else in fact! Four days later he would score his second victory, and on January 22, 1917 he was promoted to the rank of Leutnant der Reserve (Reserve Lieutenant). Not long before this date, Jasta 15 had received the new Albatros D III fighters, and Udet would score all of his 13 victories during 1917 in the cockpit of this type or its later variants, the D V and D Va.

On June 19, 1917, Erni was posted to Jasta 37, and he would take over command of that unit on November 7 of that year. In late January and early February Udet participated at the First Fighter Competition in Berlin Adlershof, where prototype types of the latest German fighter aircraft were evaluated and compared. Only the most experienced and successful frontline pilots were present at this event.



foto: via Jörn Leckscheid

Udet was appointed commander of Jasta 37 on November 7, 1917, when the unit was located on Wyngenge airfield in France. He replaced the previous commander, Lt. Grashoff. As the unit commander, Udet used this black-fuselage Albatros D Va during the winter of 1917.

Jasta 37 would move to the airfield of Le Cateau on March 15, 1918, and as they were pitching their tents there, Manfred von Richthofen, who was then stationed not too far away with his Jagdgeschwader, paid them a visit. When von Richthofen asked Udet about his current victory score, „Nineteen confirmed and one pending confirmation“ was the reply. „Then it's time for you to join us now,“ Rittmeister responded... That was too good an offer to refuse, as Richthofen's Geschwader had some of the best pilots and was always equipped with the most modern fighters. Udet arrived at Jasta 11 on March 18, 1918. His spell with Jasta 11 was rather short though, but long enough to

score three victories. As he developed a severe ear infection, von Richthofen ordered him personally to return home to recover. Udet left Jasta 11 for Munich on April 8, and he received the notification that he had been awarded the „Orden Pour-le-Mérite“ the very next day! He was still in Munich when the Rittmeister was killed just twelve days later. The ear infection needed one more month to get better, and he returned to the front on May 22, 1918, taking command of Jasta 4.

Mastering the combat

With Jasta 4, he would initially fly a type that he

Jasta 4 commander, Leutnant der Reserve Ernst Udet with his pilots in front of ex-Kirschstein's Fokker Dr.I. This photo was taken in late May, 1918, during the time of Spanish flu. It could be the reason for the bad mood, one could feel from the picture.



foto: via Jörn Leckscheid

had already used at Jasta 11, the Fokker Triplane. His new plane at Jasta 4 was in fact an old one, as he took over Fokker Dr.I 586/17, formerly flown by the leading ace of Jasta 6, Lt. Hans Kirschstein. His triplane was marked with alternating black and white stripes on the upper wing and on the rear of the fuselage. To give it his personal touch, the famous „LO“ moniker was quickly added in red to the sides of the fuselage. But this aircraft enjoyed just a brief service life with Udet. The engine lost one cylinder in early June, and Udet replaced it with Fokker Dr.I 586/17. This triplane would also be flown for only a few days, since the frontline career of the Triplanes was almost over with Jagdgeschwader von Richthofen.

On June 13, 1918, Jasta 4 converted to the new Fokker D.VIIs, as the last component unit of JG I. The other three Jasta of the Geschwader had received the new type several weeks earlier, and now Jasta 4 got it, too. One of these newly delivered Fokker D.VIIs, which were actually licence-built by the Ostdeutsche Albatros Werke (DAW) would soon be repainted into the iconic – but also somewhat mysterious – „Du doch nicht!“. But even this airplane would only enjoy a short life at the front. On June 29, 1918, at 7:40 a.m., Udet started combat with French Breguet Br.14 over Cutry. Thinking he had eliminated the observer with his first burst of machine gun fire, Udet made another attack, now little bit blithely from the side. But his mistake evinced, as the gunner suddenly opened fire, damaging the controls of Udet's new plane. The D.VII fell and Erni barely managed to bail out, landing just within the German territory.

Udet, already dressed in informal suit, is observing the wreck of BF 109/14, 15-1SLU after his crash on the field by Steinsburg, during Alpen fight, July 26, 1937.

He returned to Jasta 4 within a couple of hours, getting back into the cockpit of another Fokker D.VII later that same day – so much for the much-lamented shortage of airplanes in Fliegertruppe! While flying with Jasta 4, Udet would be credited with 39 out of his total of 62 victories. Though he was officially commanding Jasta 4 until the end of the war, he had been leading it for only about 10 or 11 weeks during that period of five and a half months in fact. That makes his record of victories even more impressive than it already is! For Udet, as well as for all officers and soldiers of the Imperial Army, the end of the war, the armistice conditions that it brought with it, and the general post war chaos in Germany meant shock and disillusion. But he quickly brushed himself off, and the twenties represented the height of his career, popularity and, without a doubt, the best years of his life.

Into the real life

Immediately in December, 1918, Udet married his love Eleonor Zink, who's moniker „LO“ adorned the sides of his fighters in the majority of his aerial fights. But he was tempted also by his second, or it could be argued, first and greatest, love, flying. With his old war buddy, Robert von Greim, he demonstrated air combat at shows, and with his American partner, William Pohl, he founded the company Udet Flugzeugbau GmbH, which designed and built aircraft. As a flyer, he flourished. As a business and family man, he did not. He divorced „Lo“ in 1923, left his company two years later, and he focused on flying and building up his status as an aerial star. He made movies, and he travelled. He also wrote of his wartime and post war exploits and gave magazine interviews. Udet also visited North and South America and in the United States, he met an old adversary in Walter

Wannamaker, whom he had shot down in June, 1918. Of course, he flew, and he partied, but he was also very well known for his flying, exceeding pretty much normal flying manners regularly. His stunts of picking up handkerchiefs from the landing strip with the wingtip of his plane are generally known to all aviation enthusiasts. He became well known for heavy partying and love affairs, and besides flying and beautiful women, he indulged in good food, alcohol, and, with the passage of time, drugs as well. The quantities of all these gradually increased.

Burden of responsibility

After the rise of the Nazi party, his former commander, Hermann Göring, convinced him to join, which he did on May 1, 1933. He was appointed the director of research and development of the new Luftwaffe subsequently. For the Nazi propaganda machine, he was an amazing tool, a star of the highest order and a role model for German youth. His wartime autobiography, Mein Fliegerleben („Ace of the Black Cross“ in English) was translated into many languages through many printings, and is still being published today. It only varies in the authors of the foreword, as the edition with a foreword by Herman Göring is no longer available, off course...

For Udet, it was very important that he had unlimited access to aircraft at the highest level, and he was truly in the thick of things in that regard. Within the newly formed RLM, he served several functions, including in the rank of Major, until on February 1, 1939, when Göring named him Generalluftzeugmeister (Director-General of Equipment for the Luftwaffe). He was gradually promoted all the way to Generaloberst (Colonel General) of the Luftwaffe (1940). Udet continued to fly, became a holder of the speed record for



foto: Hans-Heinz Stapfer via Jirř Rajlich

land based aircraft, demonstrated aerobatics at the 1936 Olympics in Berlin, and a year later, he led the German contingent at the 4th International Air Meet in Zurich. There, he was a member of the overall winning German team but was also instrumental in the saving of the life of a Czechoslovak pilot, Captain Stanislav Engler, who was missing after an emergency landing in the Alps. All that, despite having crashed himself due to engine failure suffered by his Bf 109V14 (D-ISLU), the total wreck from which he emerged unscathed! These exploits indicate how, despite all the accolades and rank, he remained true to the concept of the gentleman, friend, and colleague. But, even so, he increasingly suffered a dark side of mounting, debilitating depression, which he tried to counter through the parties, loose women and drinking. This depression became even stronger with the start of the Second World War and culminated in the fall of 1941 through increasing criticism of his role in the technical arm of the RLM. His eternal companion and adversary all-in-one might have been the actual reason for the inscription *Du doch nicht!!*, not meant as a message to Allied pilots, as is widely assumed. The amazing pilot, hero and showman took his own life on November 17, 1941. The Nazi party attributed his death to an accident while testing a new weapon. Ernst Udet is buried at the Invalidenfriedhof (Invalids' Cemetery) in Berlin. The neighbouring grave is occupied by Werner Mölders, a Second World War ace who perished in an air crash on his way to Udet's funeral.

our special thanks to
Mr. Jörn Leckscheid
 for his kind cooperation

Udet's funeral in Berlin. The honor guard at the coffin was held by pilots awarded the Knight's Cross with the Oak Leaves or the Knight's Cross with the Oak Leaves and the Swords.

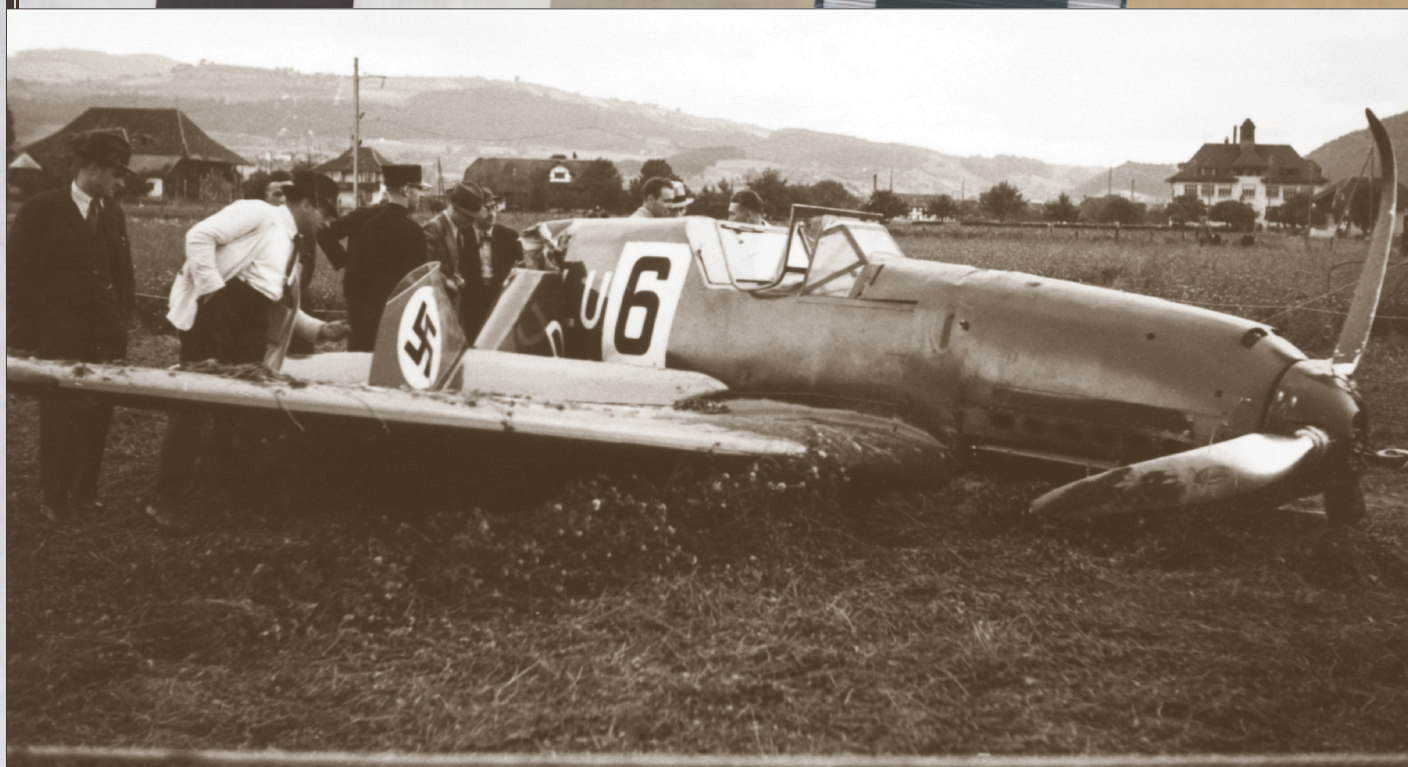
To the right of the coffin (from the photographer's perspective) is headed by Kommodore JG 3 Obstlt. Günther Lützwow, followed by Major Walter Storp, RLM officer and former commander of SKG 210. On the left of the coffin, the first is the commander of the honor guard Inspekteur der Jagdflieger Generalmajor and former Kommodore JG 26 Adolf Galland, then commander JG 2 Obstlt. Walter Oesau, behind him RLM officer and former commander of II./KG 77 Hptm. Dietrich Peltz, next in the line is probably Kommodore JG 53 Obstlt. Günther Freiherr von Maltzahn and guard of honor concludes commander II./JG 3 Hptm. Gordon Gollob.

Caption text by Jan Bobek



An interesting picture taken in Munich-Oberwiesenfeld in 1920. „Lo“ is standing in front of the Rumpler C.I, behind the plane is „Erni“ leaning on the fuselage, next to him is his father Adolf Udet.

foto: Berliner illustrierte Zeitung 45/1920 via Fotobanka ČTK



This is not a landing! This is an air show by Ernst Udet! You can't see such a show today! See the silk hat over the cockpit.

foto: Berliner illustrierte Zeitung 17/1933 via Fotobanka ČTK



foto: Berliner Volkszeitung, 21. 11. 1941 via Fotobanka ČTK

ATTENTION



UPOZORNĚNÍ



ACHTUNG



ATTENTION



注意



Carefully read instruction sheet before assembling. When you use glue or paint, do not use near open flame and use in well ventilated room. Keep out of reach of small children. Children must not be allowed to suck any part, or pull vinyl bag over the head.



Před započatím stavby si pečlivě prostudujte stavební návod. Při používání barev a lepidla pracujte v dobře větrané místnosti. Lepidla ani barvy nepoužívejte v blízkosti otevřeného ohně. Model není určen malým dětem, mohlo by dojít k požití drobných dílů.

INSTRUCTION SIGNS

* INSTR. SYMBOLS

* INSTRUKTION SINNBILDEN

* SYMBOLES

* 記号の説明

OPTIONAL
VOLBABEND
OHNOUTSAND
BROUSITOPEN HOLE
VYVRTAT OTVORSYMETRICAL ASSEMBLY
SYMETRICKÁ MONTÁŽREMOVE
ODŘÍZNOUTREVERSE SIDE
OTOČITAPPLY EDUARD MASK
AND PAINT
POUŽÍT EDUARD MASK
NABARVIT

PARTS



DÍLY



TEILE



PIÈCES



部品

PLASTIC PARTS

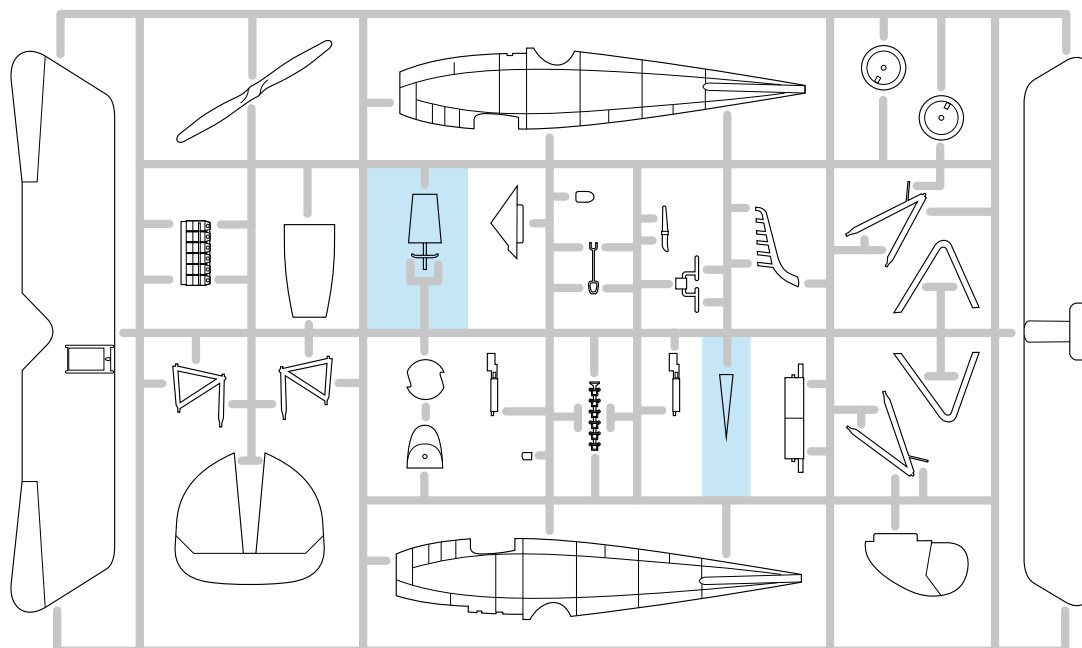
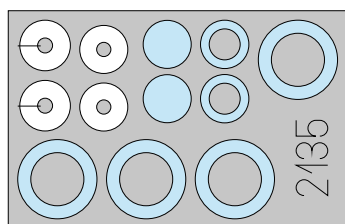
eduard
MASK

PE - PHOTO ETCHED DETAIL PARTS

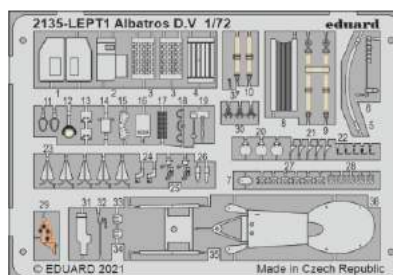

-Parts not for use. -Teile werden nicht verwendet. -Pièces à ne pas utiliser. -Tyto díly nepoužívejte při stavbě. - 使用しない部品

COLOURS



BARVY



FARBEN



PEINTURE



色

GSI Creos (GUNZE)		MISSION MODELS	
AQUEOUS	Mr.COLOR	PAINTS	
H8	C8		SILVER
H11	C62	MMP-001	FLAT WHITE
H12	C33	MMP-047	FLAT BLACK
H37	C43		WOOD BROWN
H39	C67		PURPLE
H47	C41	MMP-012	RED BROWN
H51	C11	MMP-063	GRAY

GSI Creos (GUNZE)		MISSION MODELS	
AQUEOUS	Mr.COLOR	PAINTS	
H70	C60	MMP-056	GRAY
H330	C361	MMP-077	DARK GREEN
Mr.METAL COLOR		METALLICS	
	MC214	MMM-001	DARK IRON
	MC219	MMM-009	BRASS
Mr.COLOR SUPER METALLIC		METALLICS	
	SM201	MMC-001	SUPER FINE SILVER

Albatros D.V/D.Va

A

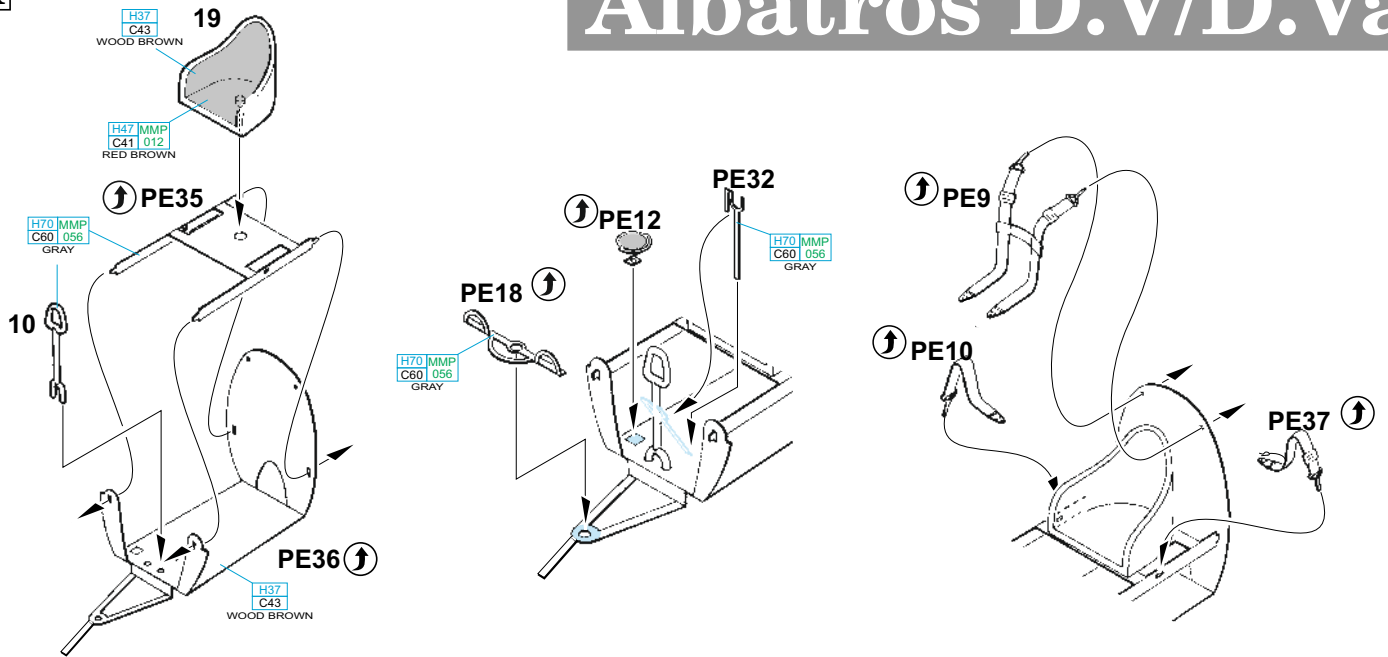

C

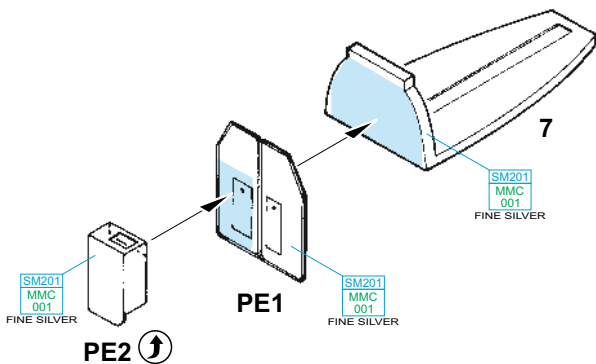

B

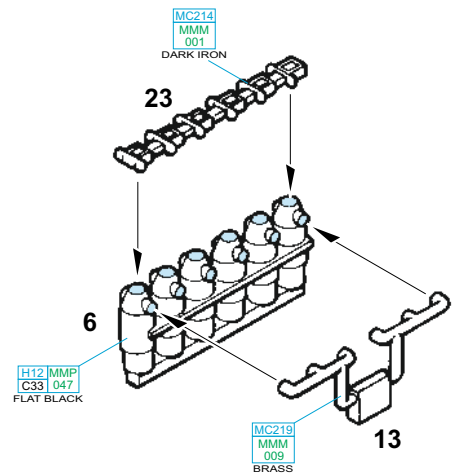

D

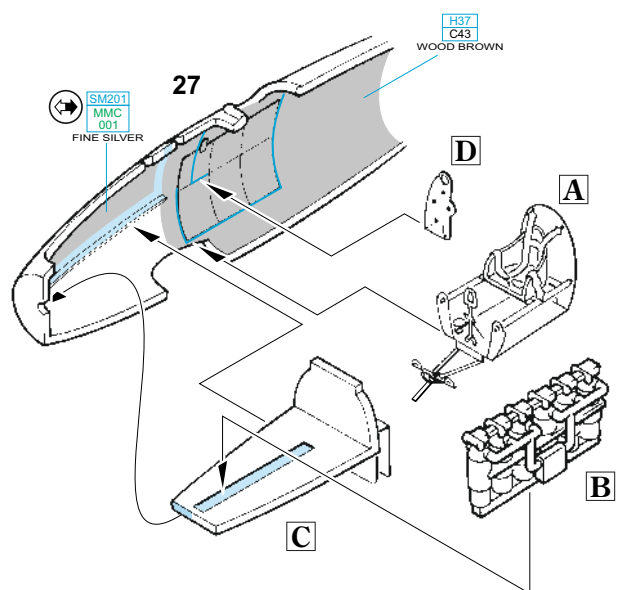
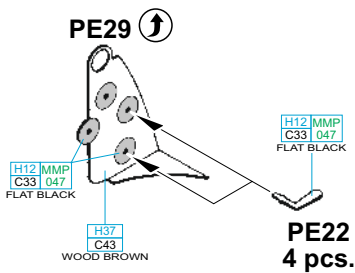

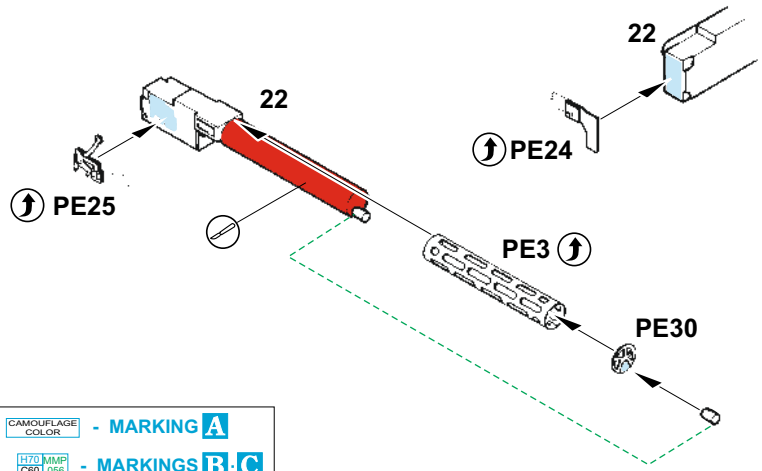
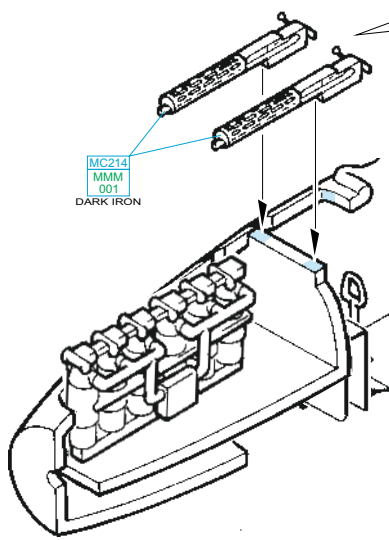

1 = CAMOUFLAGE DOLOR - MARKING A
H70 MMP C361 C356 GRAY - MARKINGS B, C

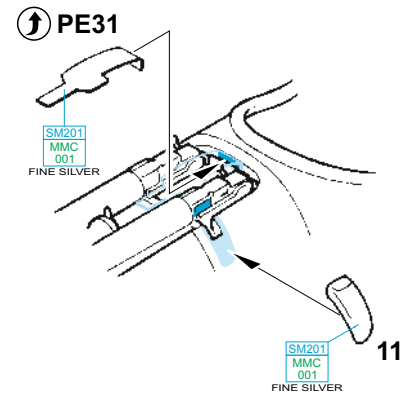
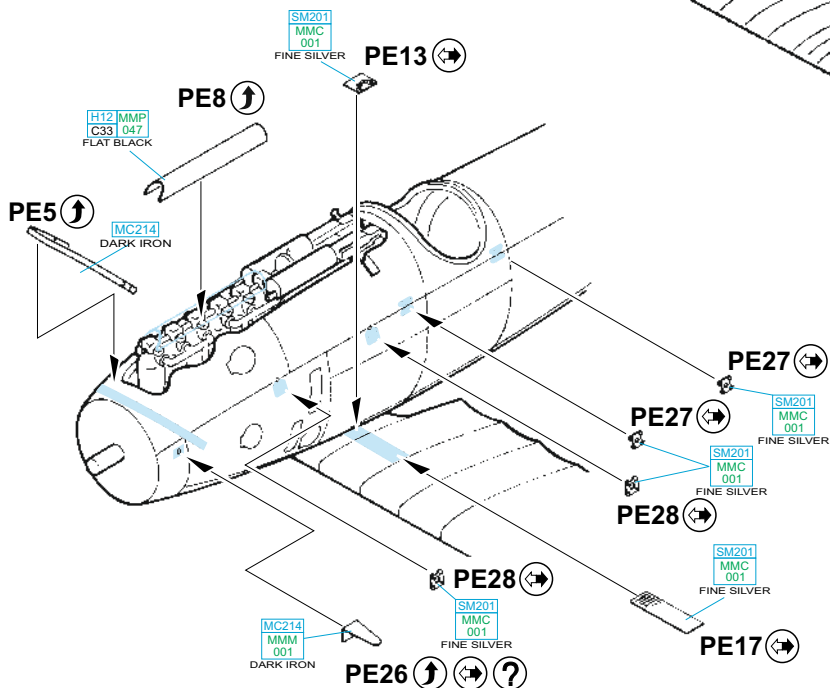
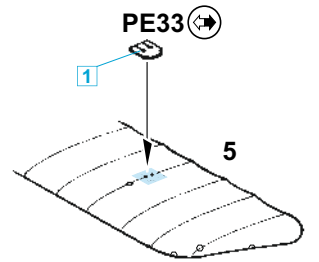
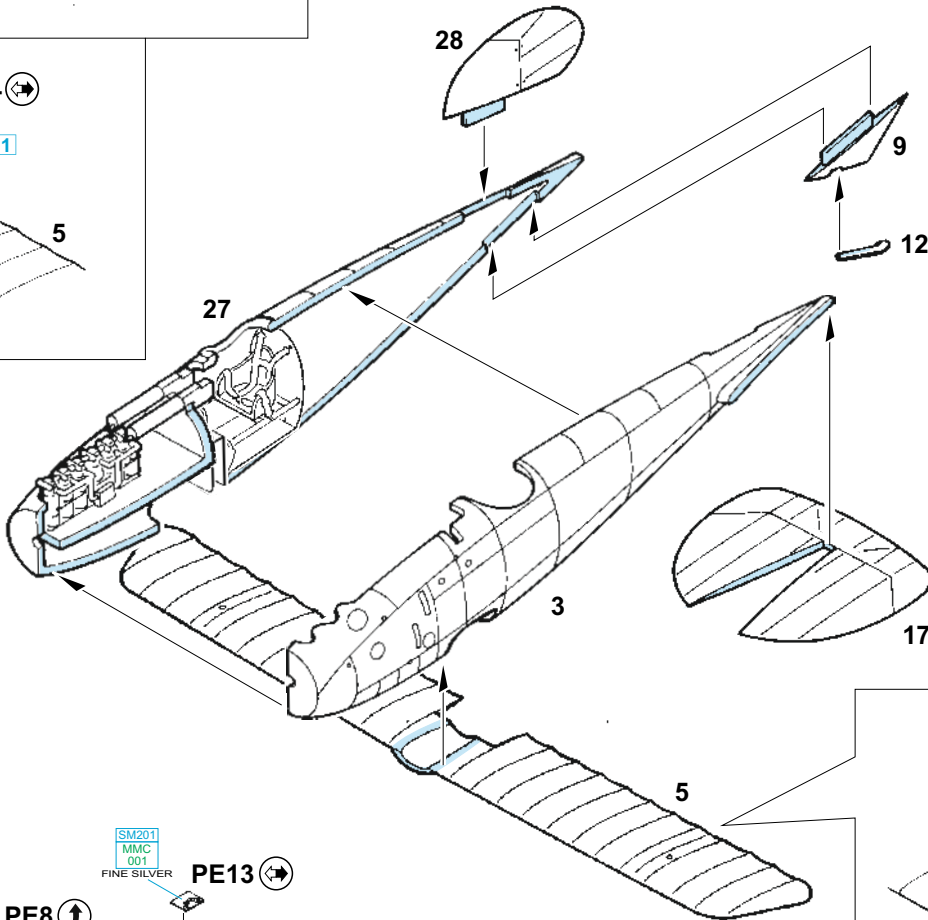
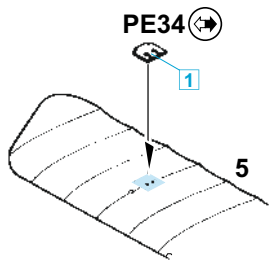

2 = CAMOUFLAGE COLOR - MARKINGS A, C
 H70 MMP C60 056 GRAY - MARKING B

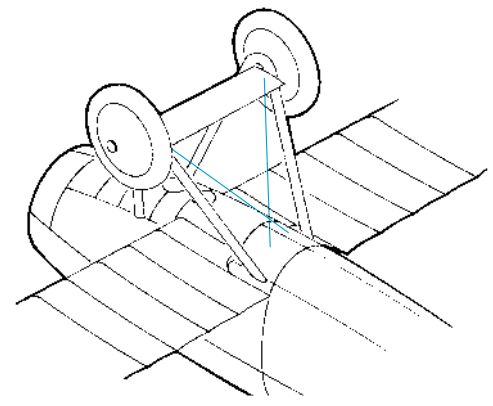
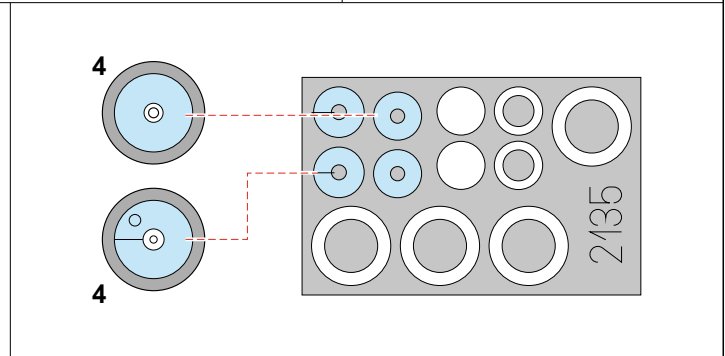
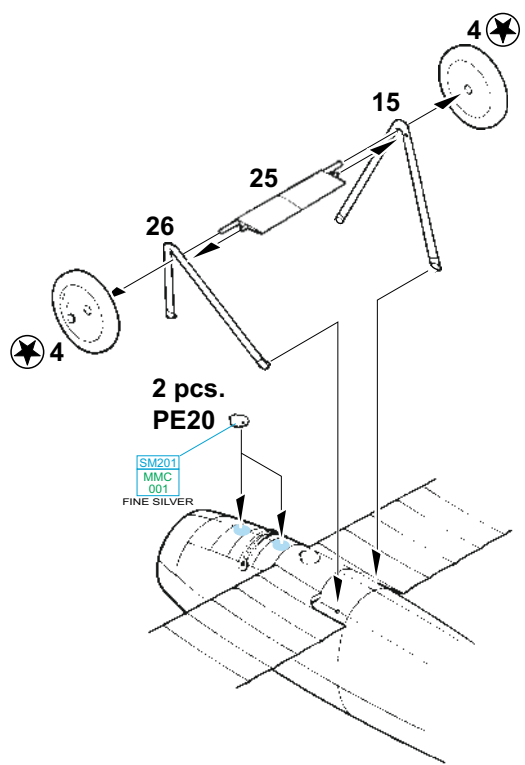
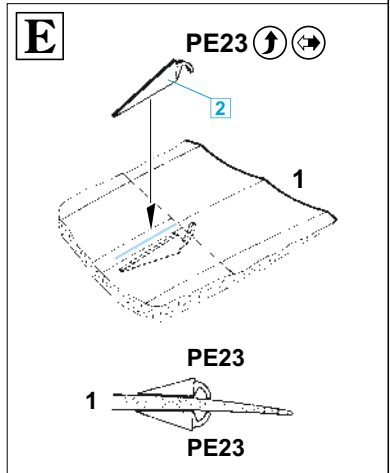
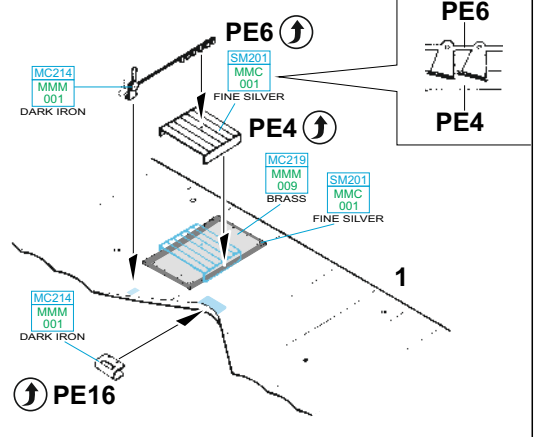
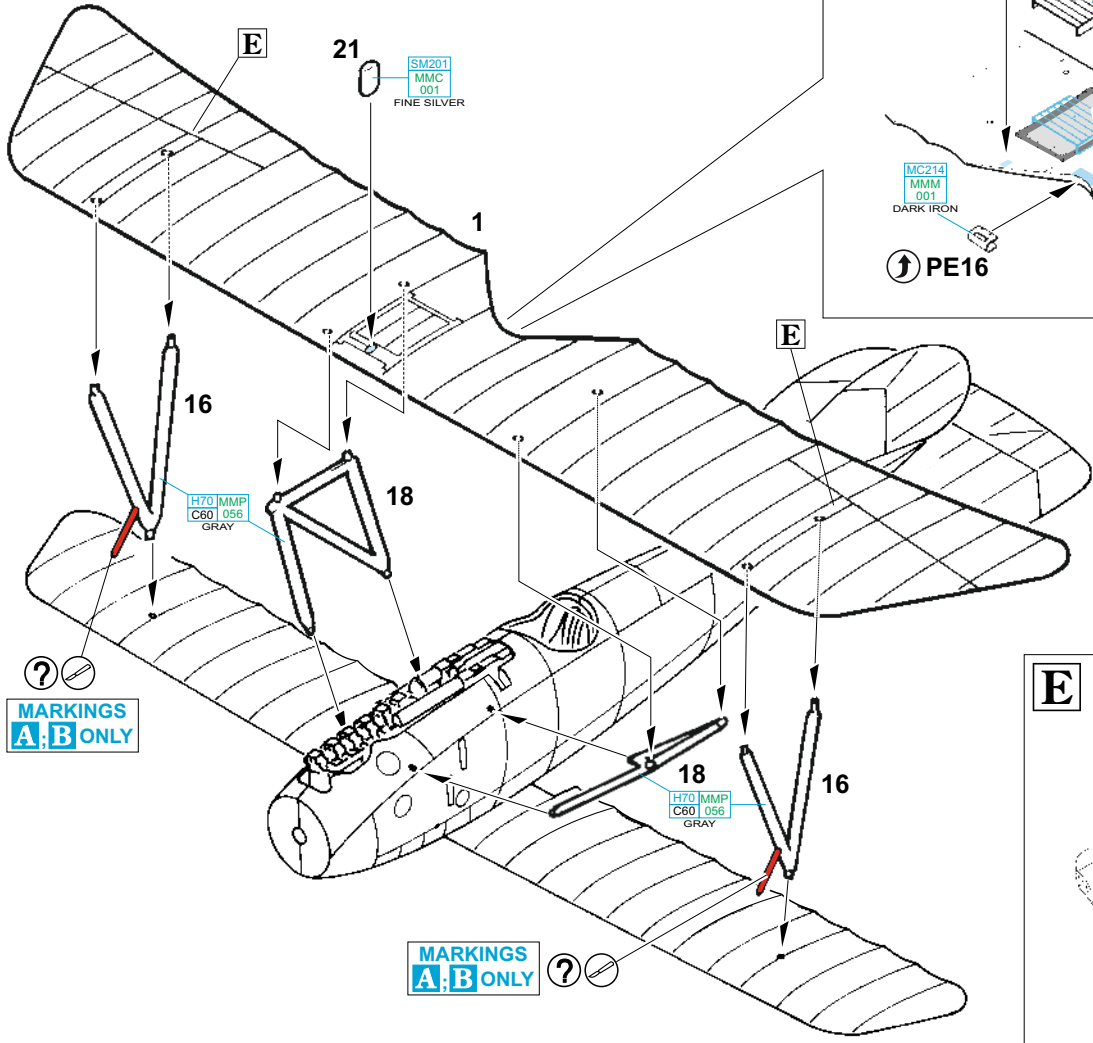

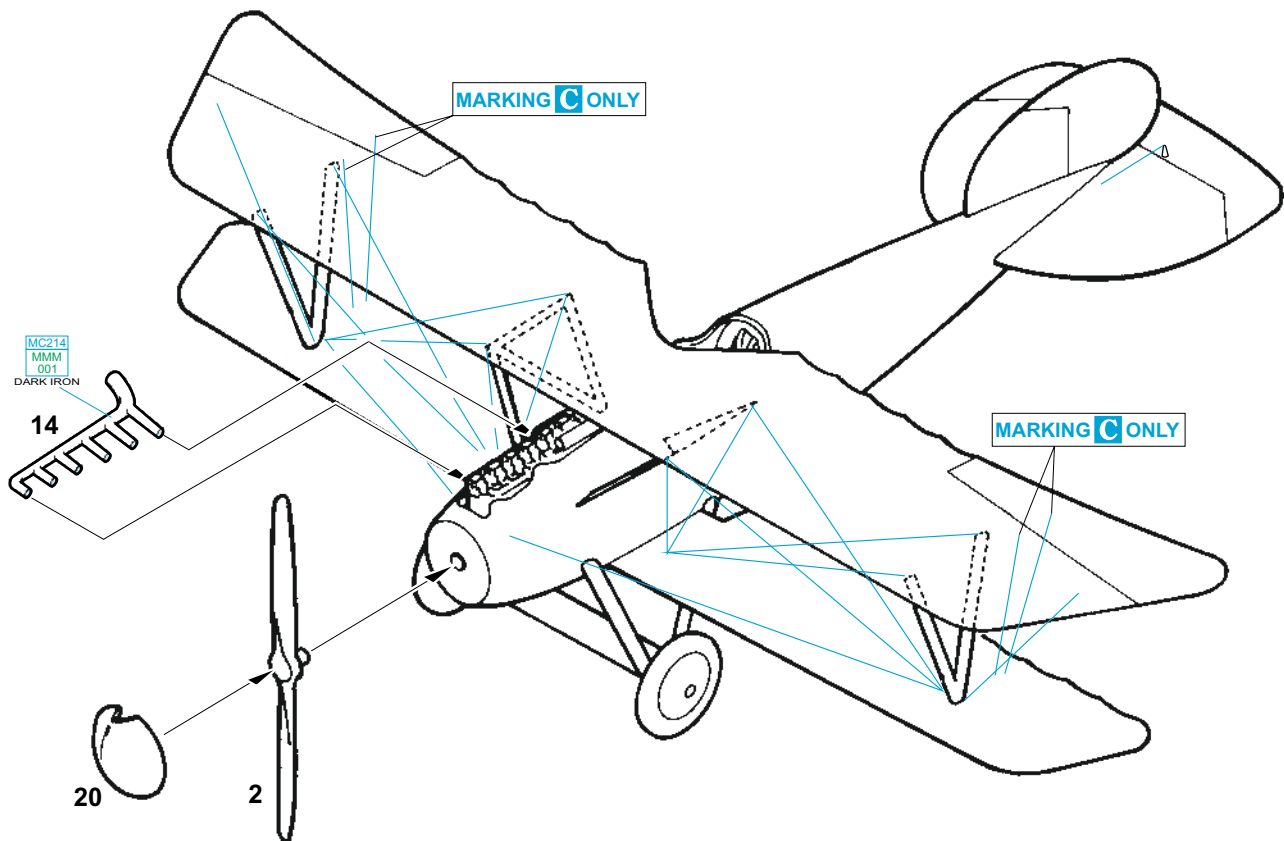
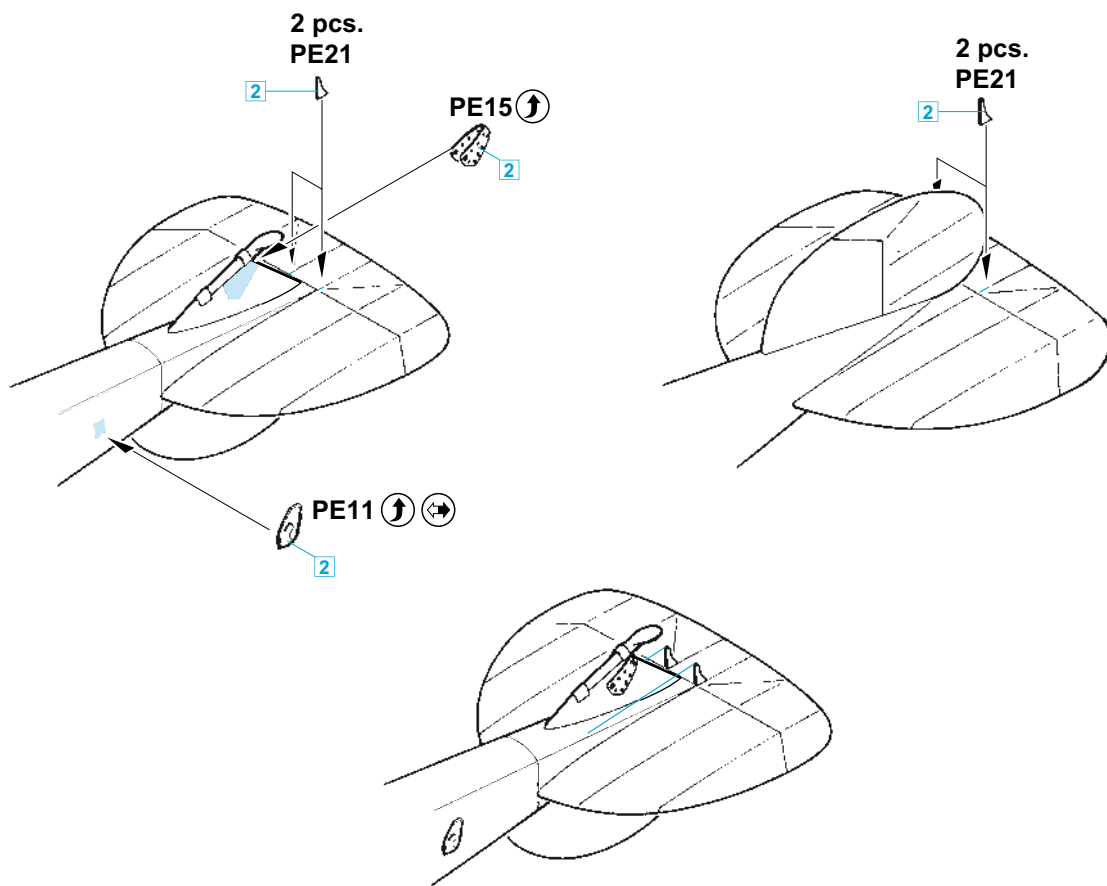

ATTENTION



UPOZORNĚNÍ



ACHTUNG



ATTENTION



注意



Carefully read instruction sheet before assembling. When you use glue or paint, do not use near open flame and use in well ventilated room. Keep out of reach of small children. Children must not be allowed to suck any part, or pull vinyl bag over the head.



Před započatím stavby si pečlivě prostudujte stavební návod. Při používání barev a lepidel pracujte v dobře větrané místnosti. Lepidla ani barvy nepoužívejte v blízkosti otevřeného ohně. Model není určen malým dětem, mohlo by dojít k požití drobných dílů.

INSTRUCTION SIGNS



INSTR. SYMBOLS



INSTRUKTION



SINNBILDEN



SYMBOLES

記号の説明

OPTIONAL
VOLBABEND
OHNOUTSAND
BROUSITOPEN HOLE
VYVRTAT OTVORSYMETRICAL ASSEMBLY
SYMETRICKÁ MONTÁŽREMOVE
ODŘÍZNOUTREVERSE SIDE
OTOČITAPPLY EDUARD MASK
AND PAINT
POUŽIT EDUARD MASK
NABARVIT

PARTS



DÍLY



TEILE



PIÈCES



部品

PLASTIC PARTS

A>

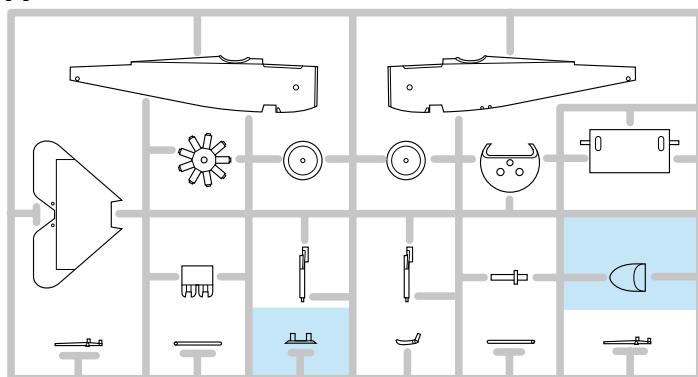

PE - PHOTO ETCHED DETAIL PARTS

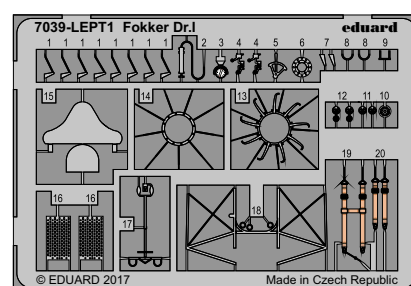

B>

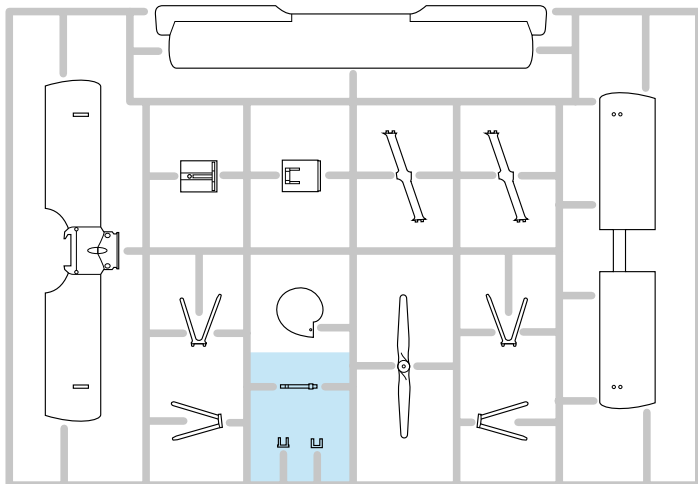
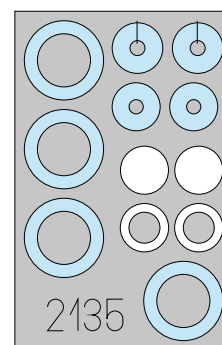
eduard
MASK

-Parts not for use. -Teile werden nicht verwendet. -Pièces à ne pas utiliser. -Tyto díly nepoužívejte při stavbě. - 使用しない部品

COLOURS



BARVY



FARBEN



PEINTURE



色

GSI Creos (GUNZE)		MISSION MODELS	
AQUEOUS	Mr.COLOR	PAINTS	
H11	C62	MMP-001	FLAT WHITE
H12	C33	MMP-047	FLAT BLACK
H27	C44		TAN
H37	C43		WOOD BROWN
H47	C41	MMP-012	RED BROWN
H51	C11	MMP-063	LIGHT GULL GRAY
H52	C12	MMP-091	OLIVE DRAB
H67	C115	MMP-057	LIGHT BLUE

GSI Creos (GUNZE)		MISSION MODELS	
AQUEOUS	Mr.COLOR	PAINTS	
H70	C60	MMP-056	GRAY
H85	C45		SAIL COLOR
H422	C122	MMP-053	LIGHT GREEN
Mr.METAL COLOR		METALLICS	
	MC214	MMM-001	DARK IRON
	MC218	MMM-003	ALUMINIUM
	MC219	MMM-009	BRASS

Fokker Dr.I

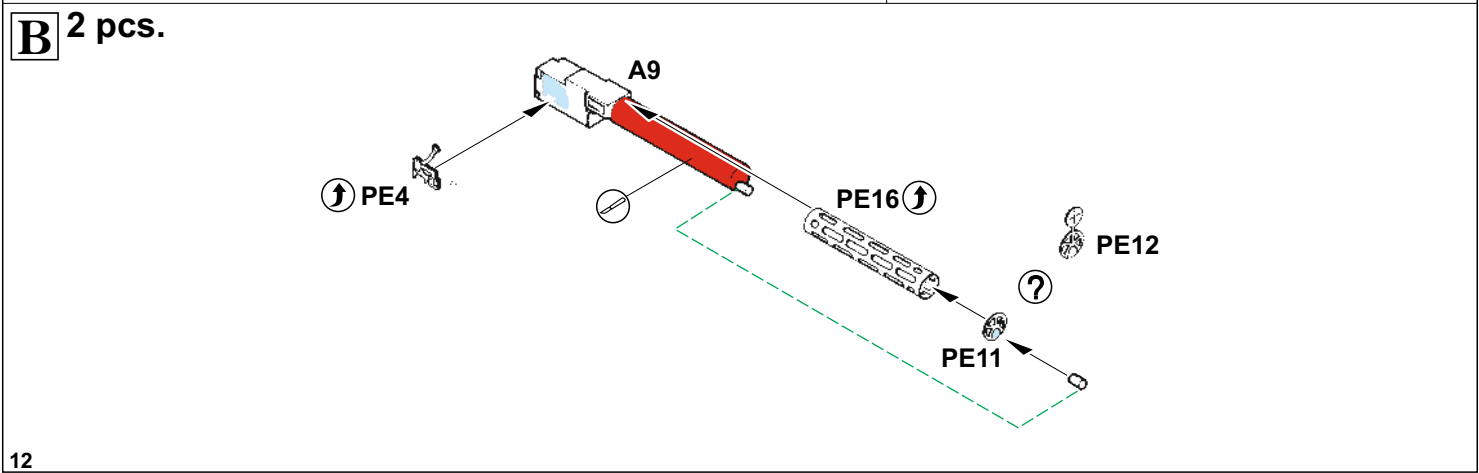
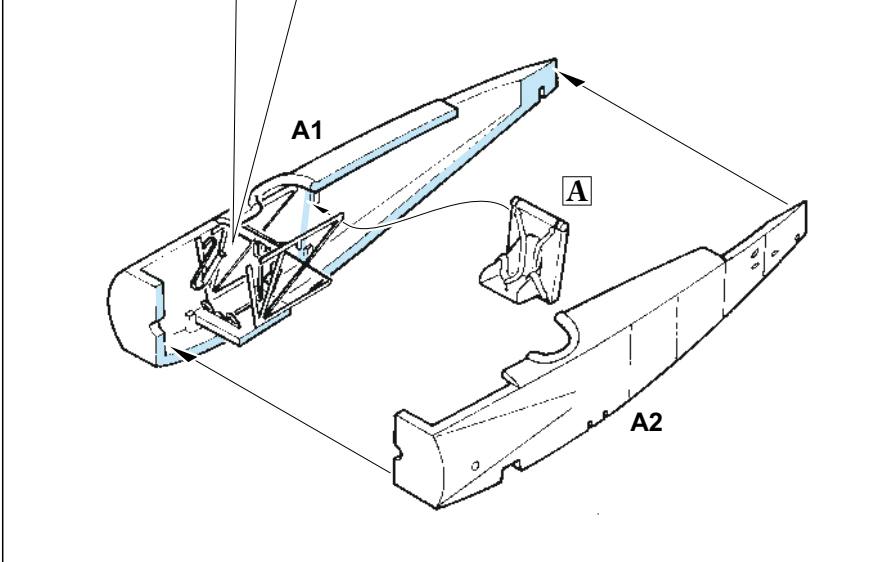
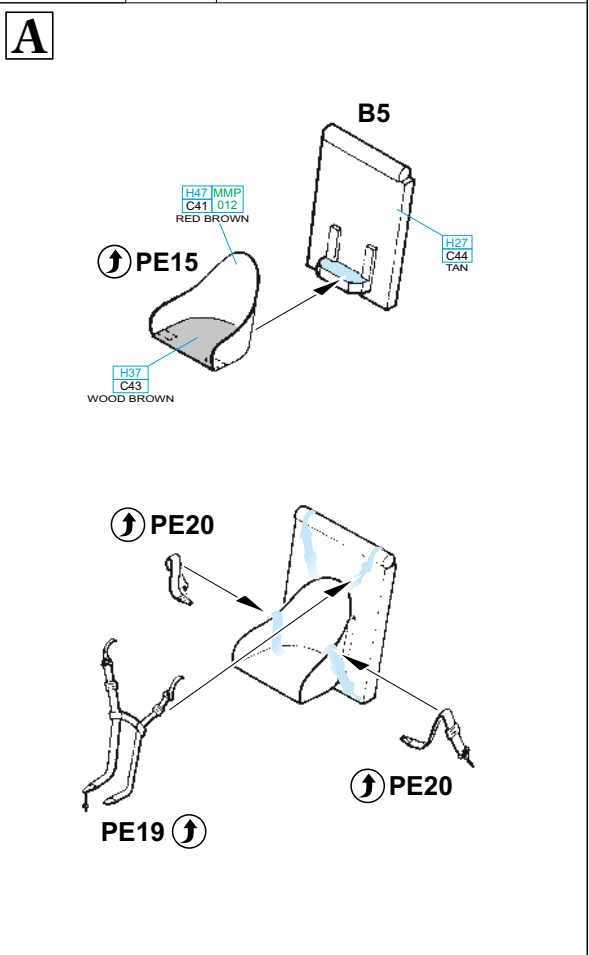
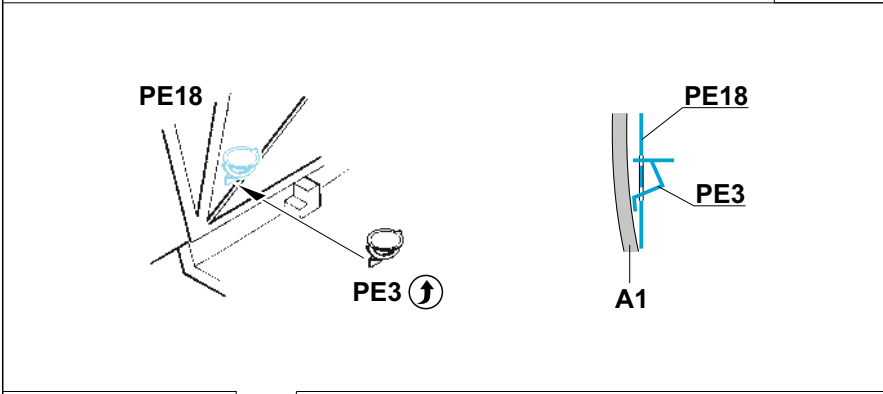
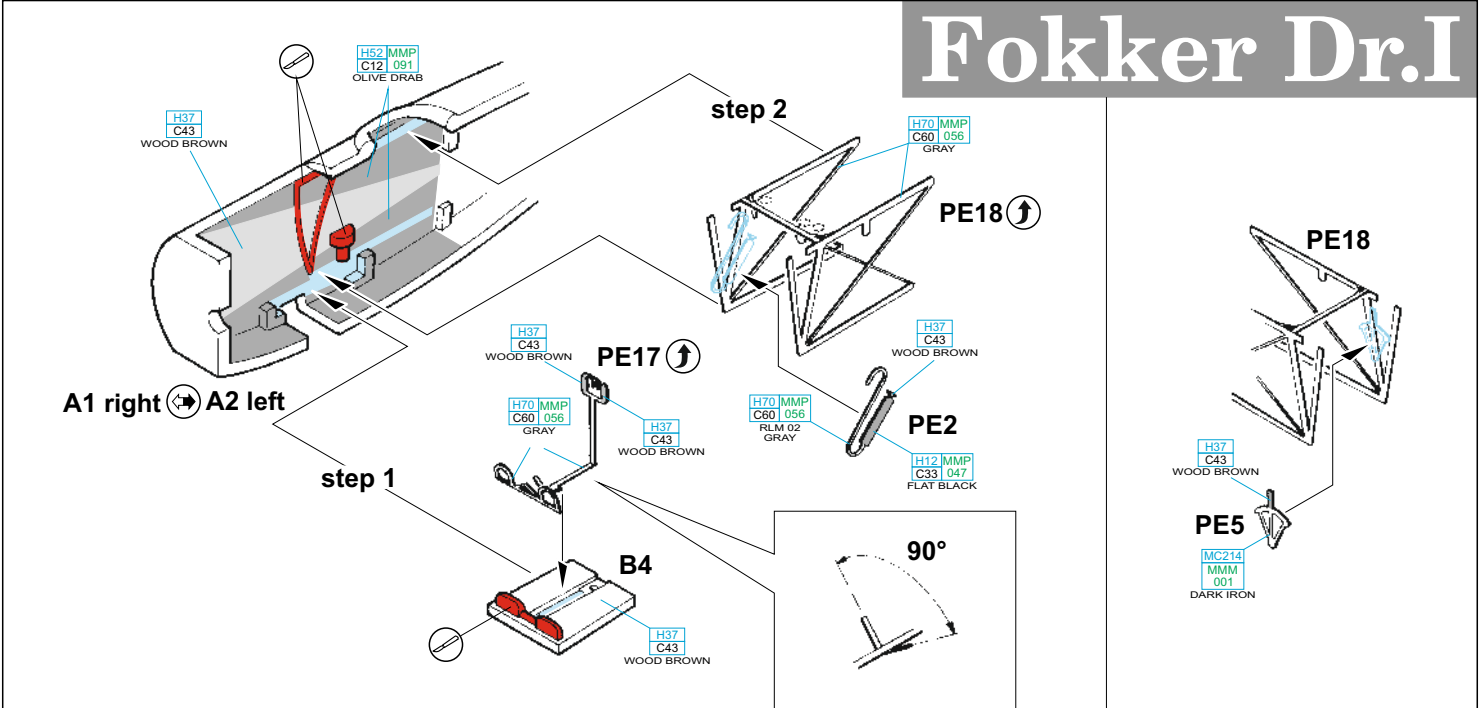

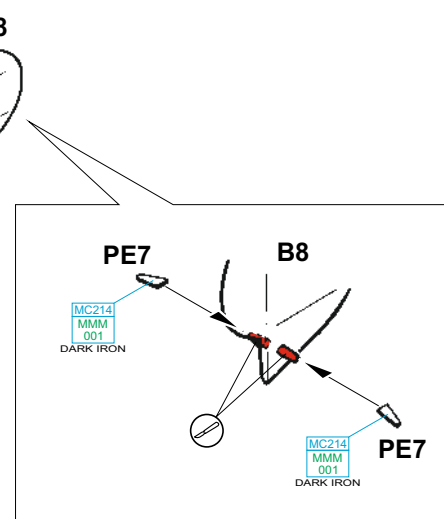
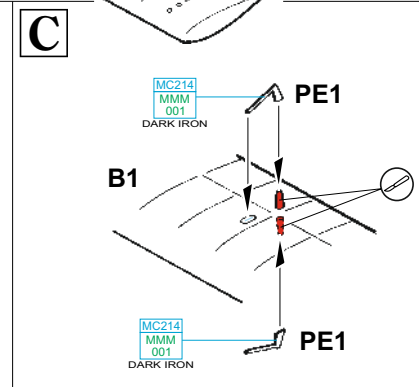
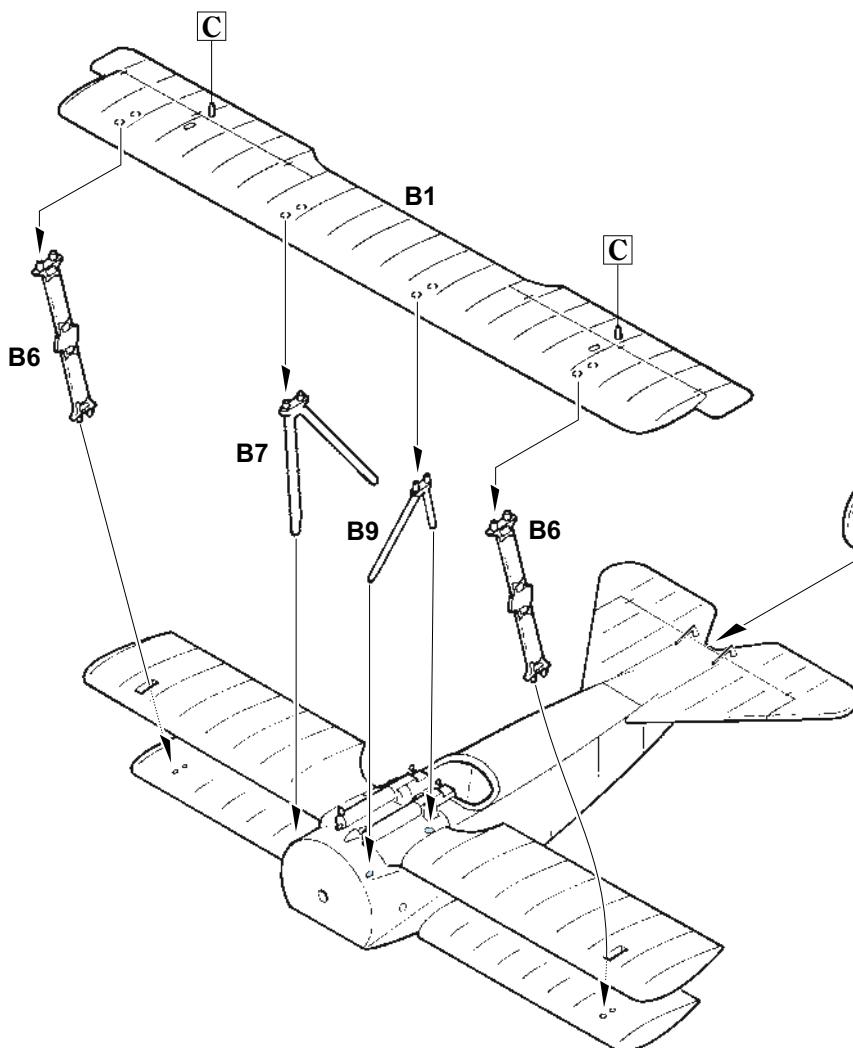
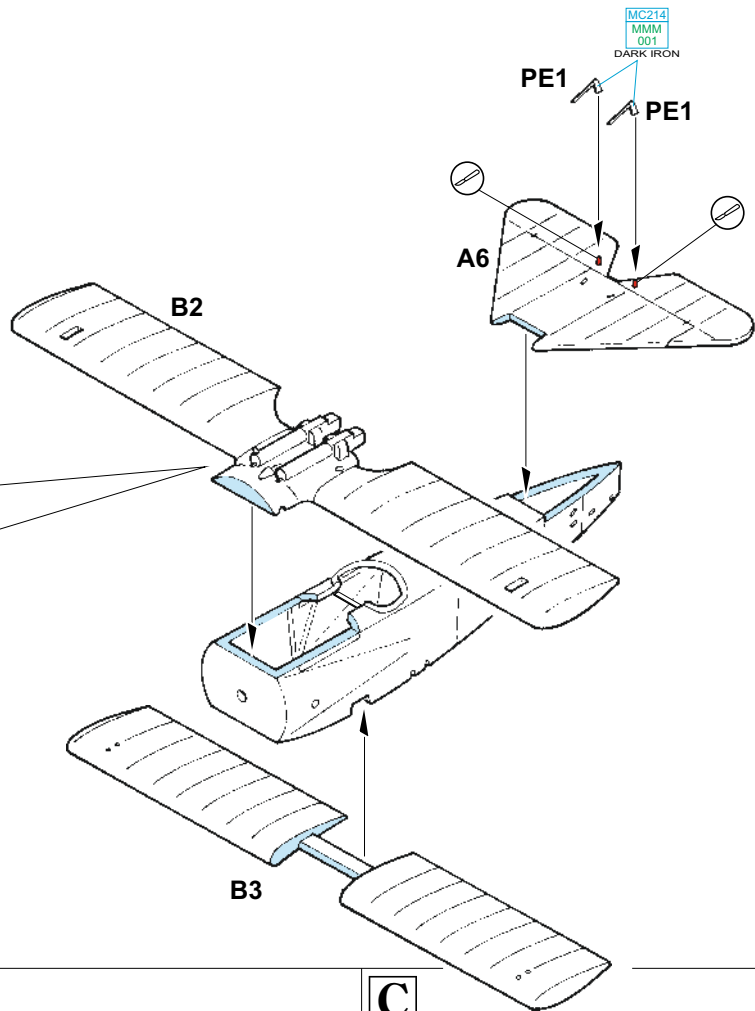
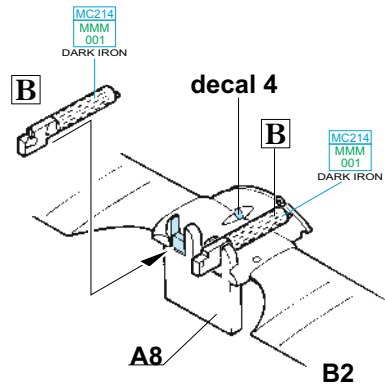
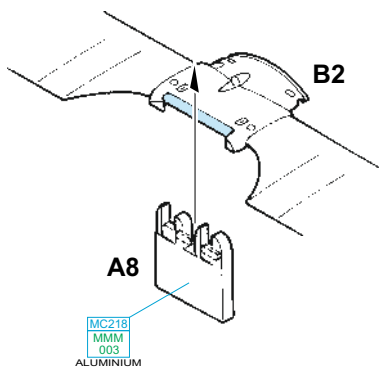

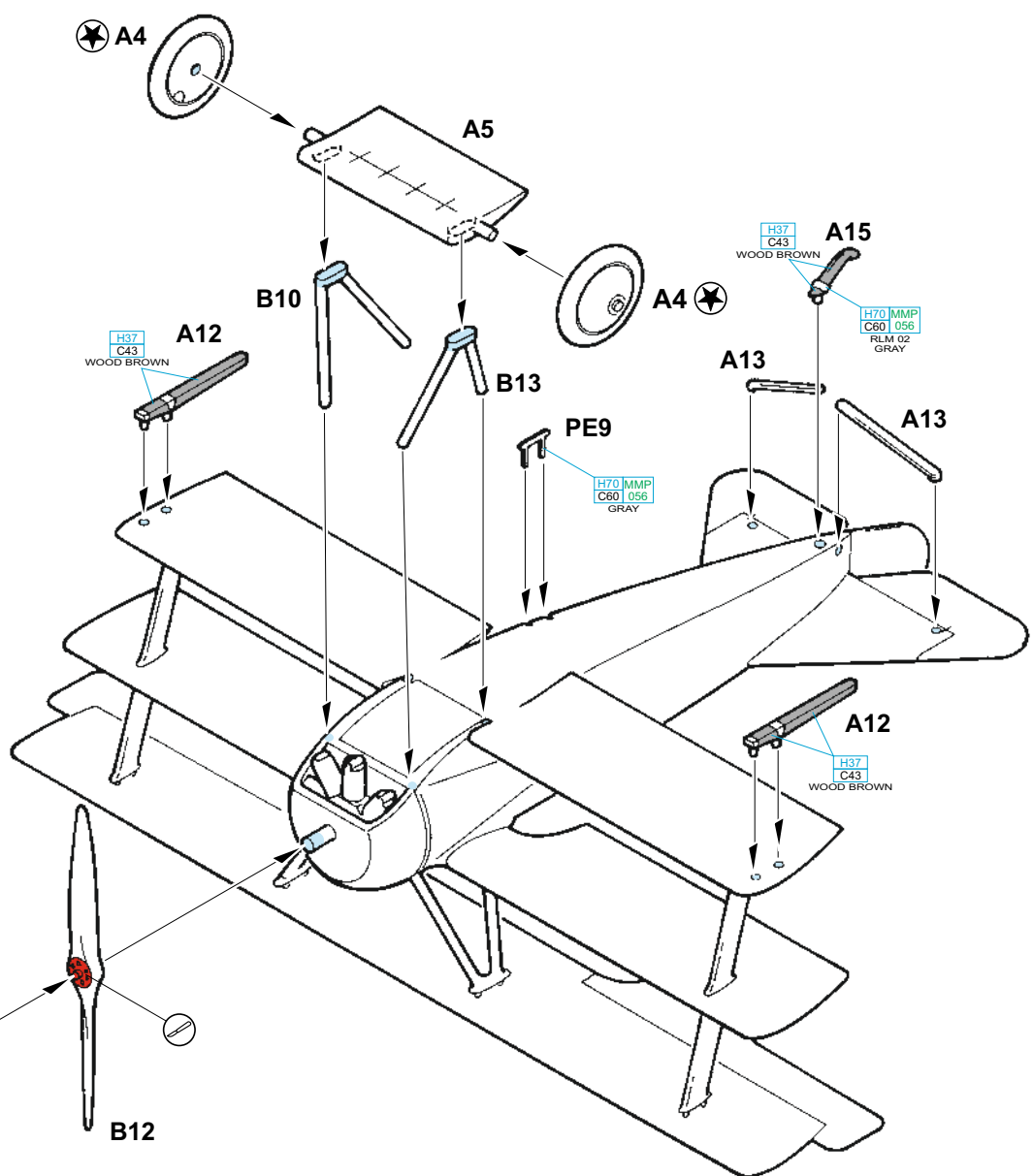
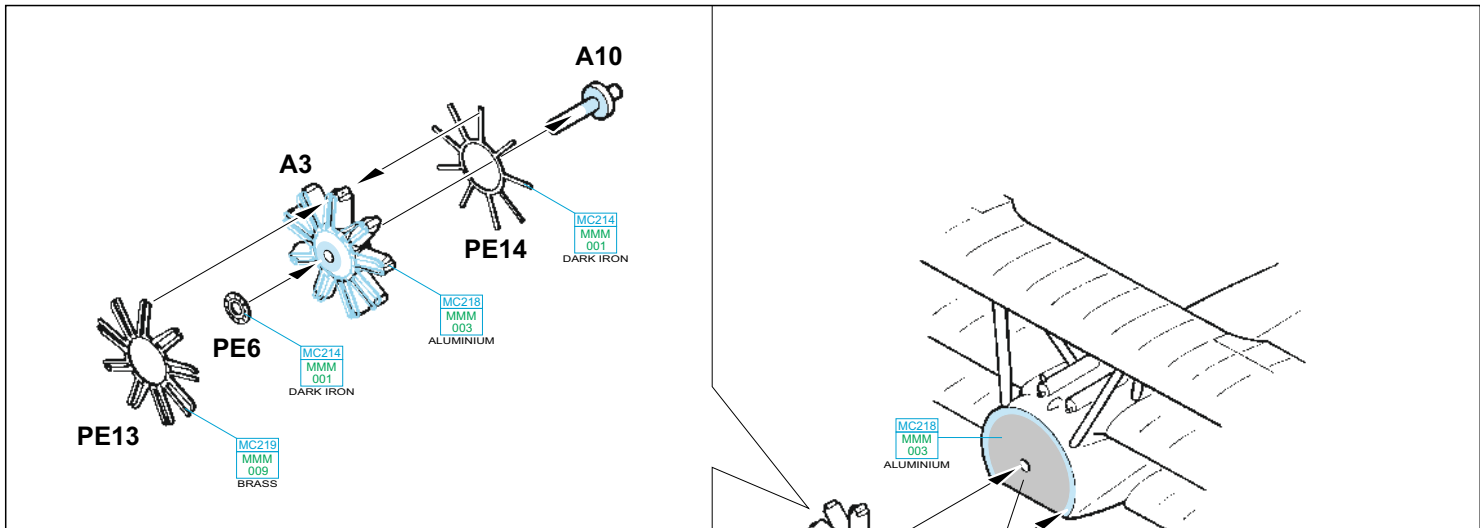

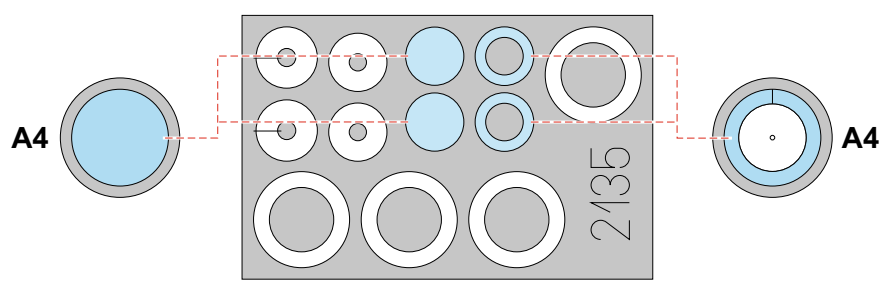
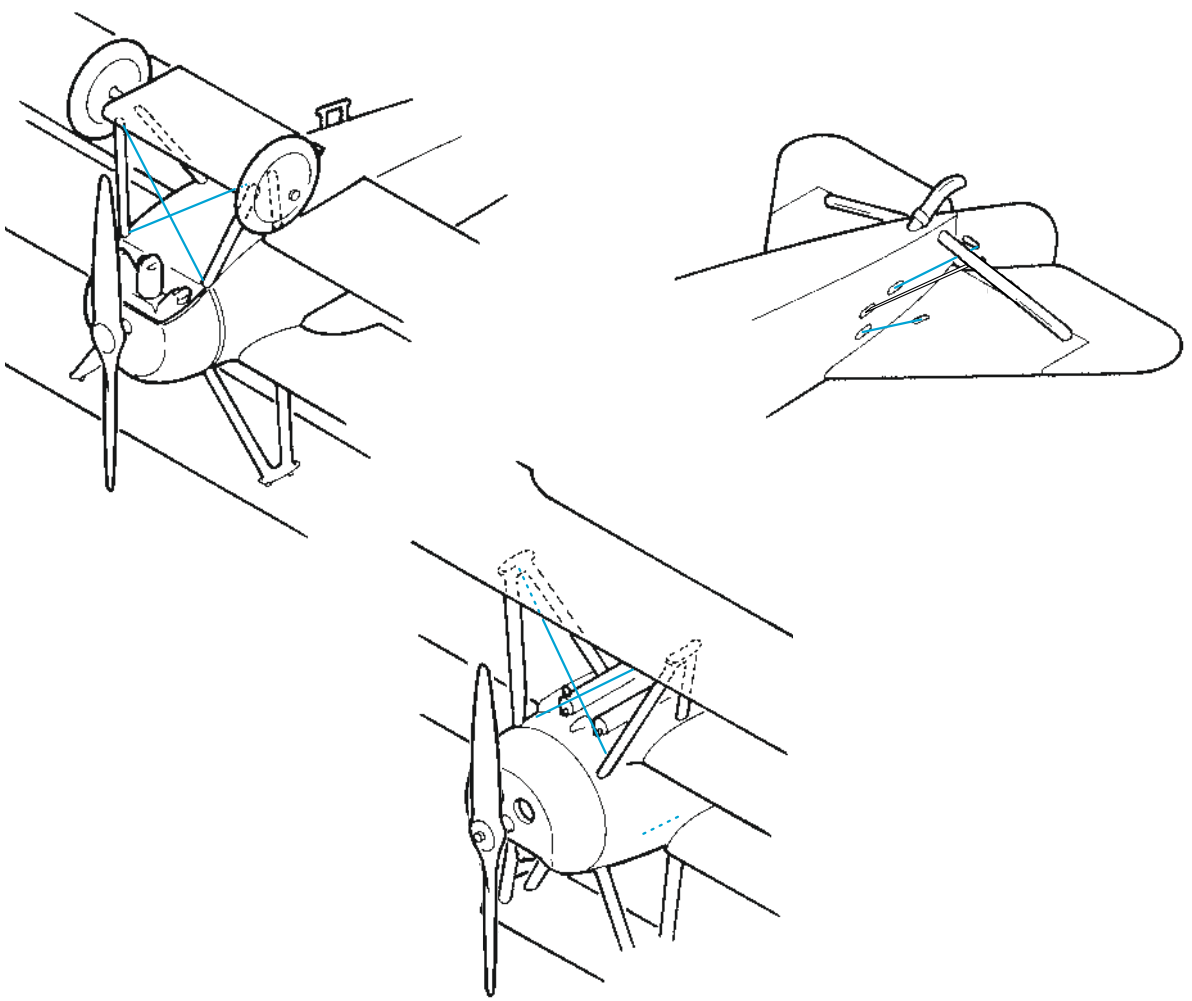
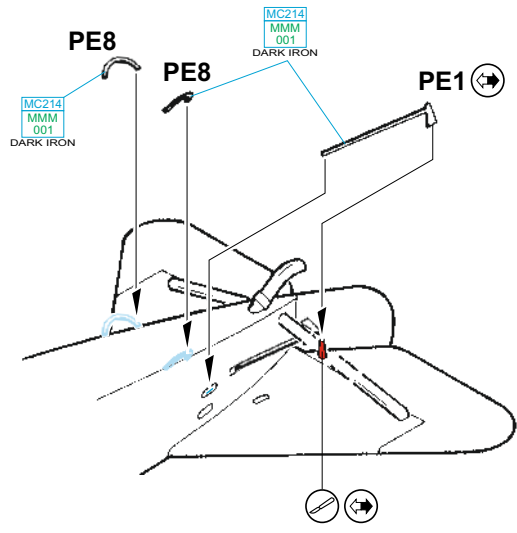

ATTENTION



UPOZORNĚNÍ



ACHTUNG



ATTENTION



注意



Carefully read instruction sheet before assembling. When you use glue or paint, do not use near open flame and use in well ventilated room. Keep out of reach of small children. Children must not be allowed to suck any part, or pull vinyl bag over the head.



Před započítím stavby si pečlivě prostudujte stavební návod. Při používání barev a lepidla pracujte v dobře větrané místnosti. Lepidla ani barvy nepoužívejte v blízkosti otevřeného ohně. Model není určen malým dětem, mohlo by dojít k požití drobných dílů.

INSTRUCTION SIGNS * INSTR. SYMBOLS * INSTRUKTION SINNBILDEN * SYMBOLES * 記号の説明

OPTIONAL
VOLBABEND
OHNOUTSAND
BROUSITOPEN HOLE
VYVRTAT OTVORSYMETRICAL ASSEMBLY
SYMETRICKÁ MONTÁŽREMOVE
ODŘÍZNOUTREVERSE SIDE
OTOČITAPPLY EDUARD MASK
AND PAINT
POUŽIT EDUARD MASK
NABARVIT

PARTS



DÍLY



TEILE



PIÈCES



部品

PLASTIC PARTS

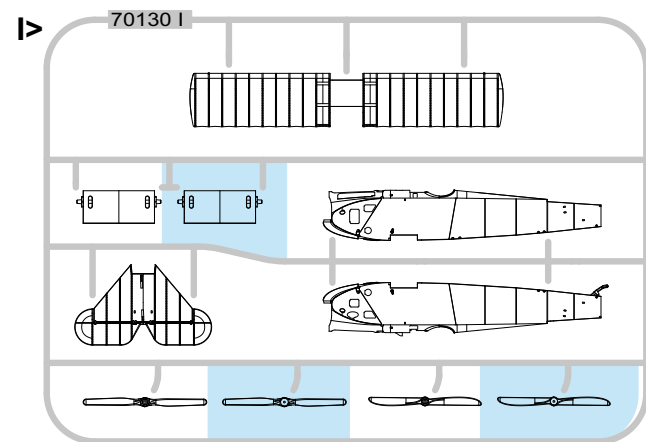
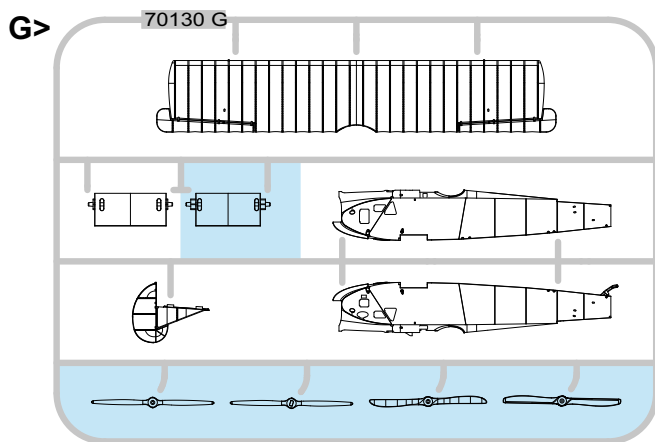
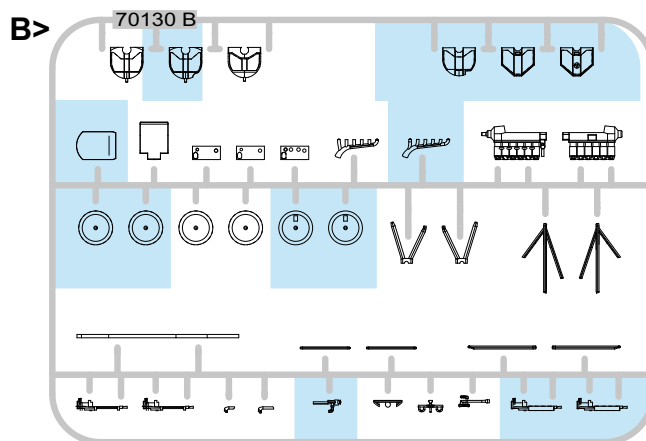
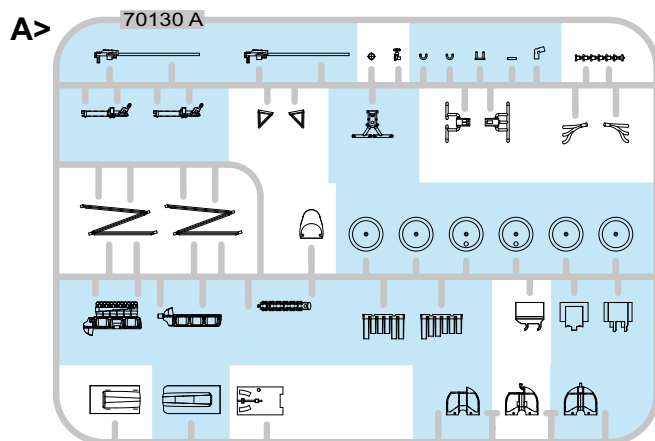

PE - PHOTO ETCHED DETAIL PARTS

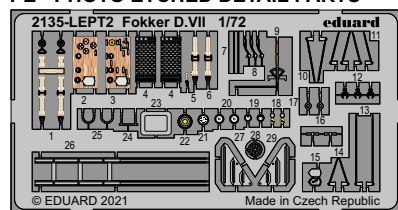
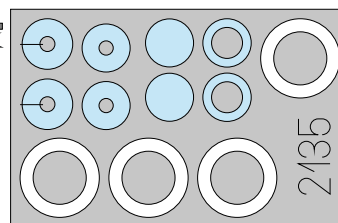
eduard
MASK

-Parts not for use. -Teile werden nicht verwendet. -Pièces à ne pas utiliser. -Tyto díly nepoužívejte při stavbě. - 使用しない部品

COLOURS



BARVY



FARBEN



PEINTURE



色

GSI Creos (GUNZE)		MISSION MODELS	
AQUEOUS	Mr.COLOR	PAINTS	
H8	C8	SILVER	
H11	C62	FLAT WHITE	
H12	C33	FLAT BLACK	
H13	C3	FLAT RED	
H37	C43	WOOD BROWN	
H39	C67	PURPLE	
H47	C41	RED BROWN	
H51	C11	LIGHT GULL GRAY	
H53	C13	NEUTRAL GRAY	

GSI Creos (GUNZE)		MISSION MODELS	
AQUEOUS	Mr.COLOR	PAINTS	
H85	C45	SAIL COLOR	
H315	C315	GRAY	
H330	C361	DARK GREEN	
H414	C114	RED	
H423	C123	DARK GREEN	
Mr.METAL COLOR		METALLICS	
MC214		DARK IRON	
MC219		BRASS	

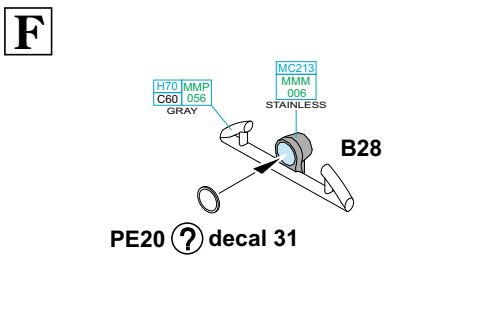
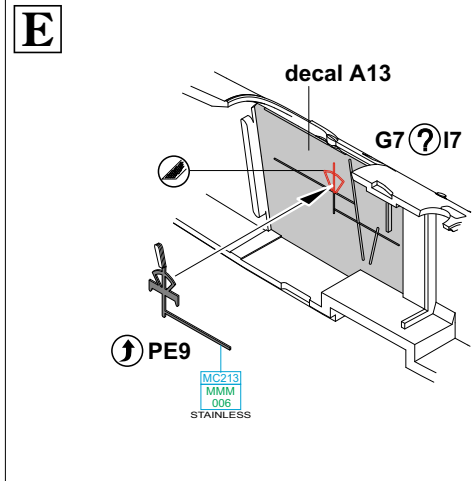
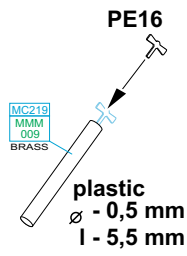
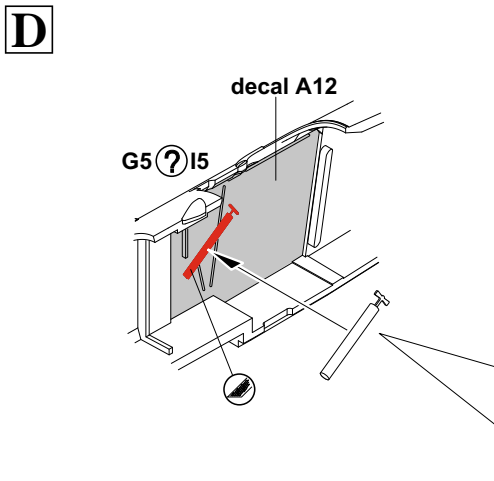
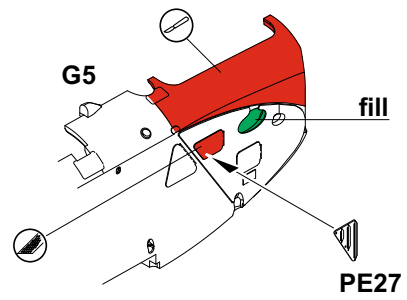
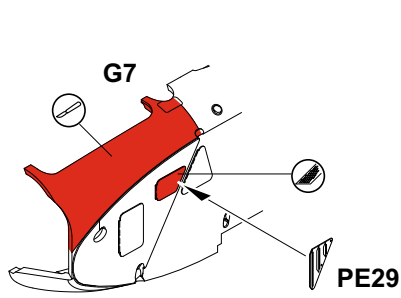

G5 - MARKING H
I5 - MARKINGS F, G

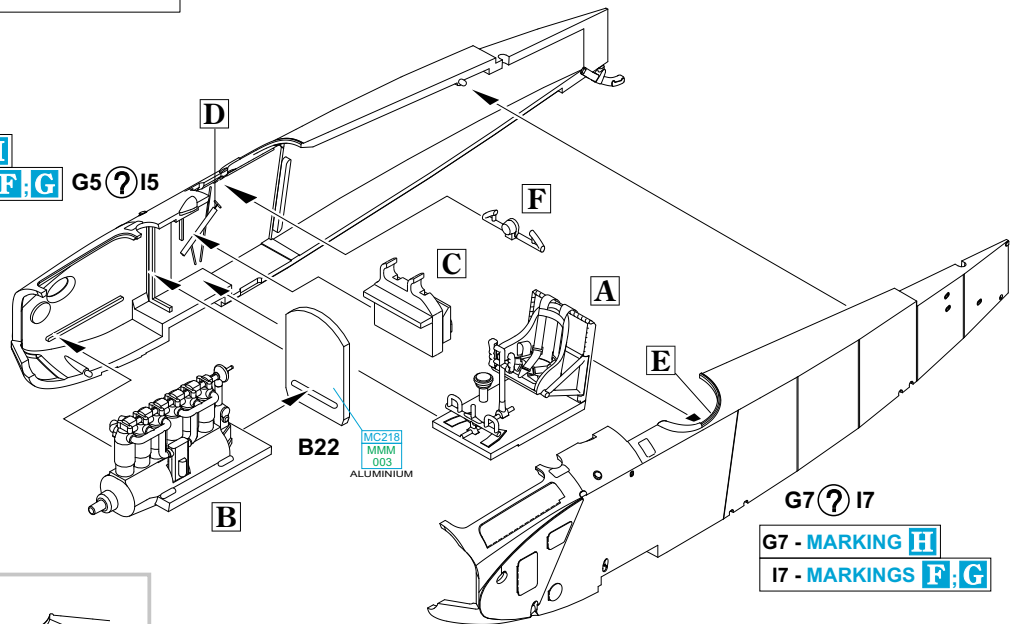

G7 - MARKING H
I7 - MARKINGS F, G

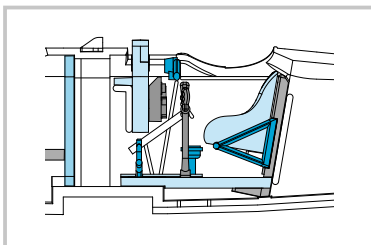

G

PE19 ? decal 42

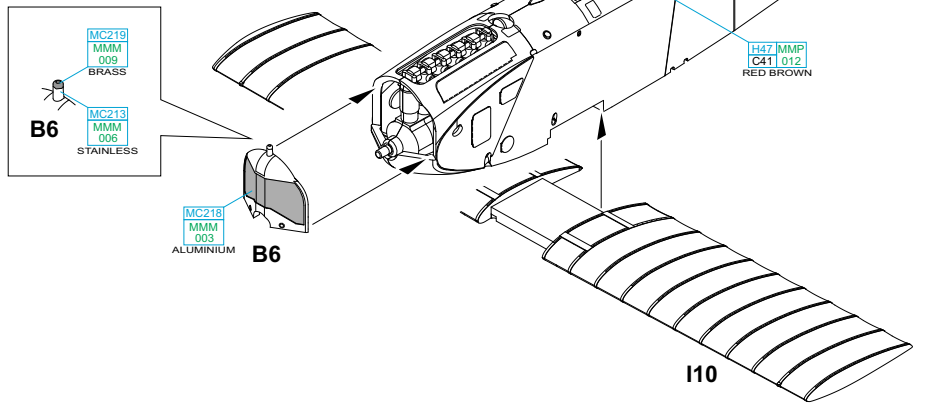
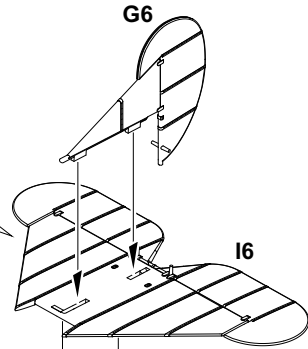
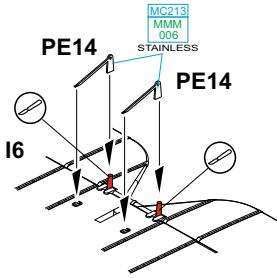
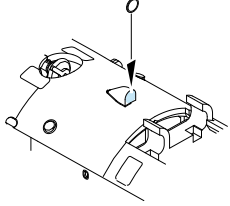
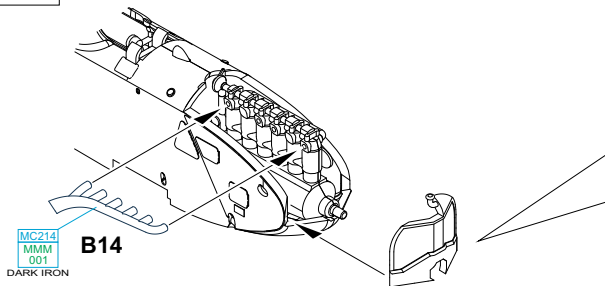
MARKING **H** ONLY

2 pcs.

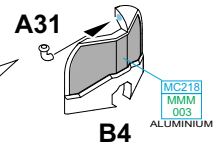
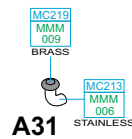
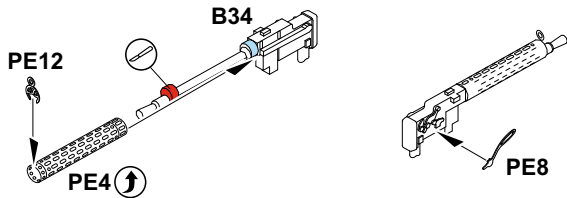
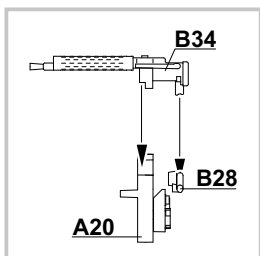
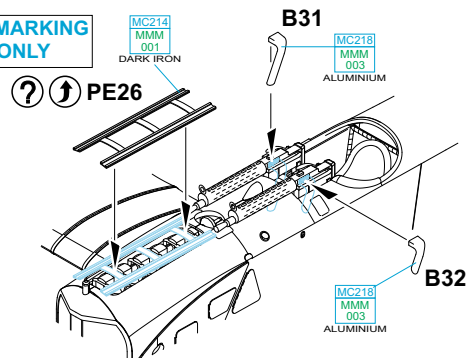
PE26 - MARKING **H** ONLY

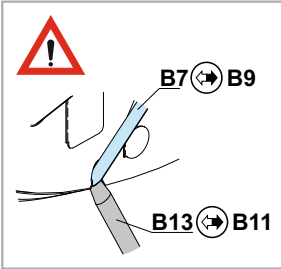
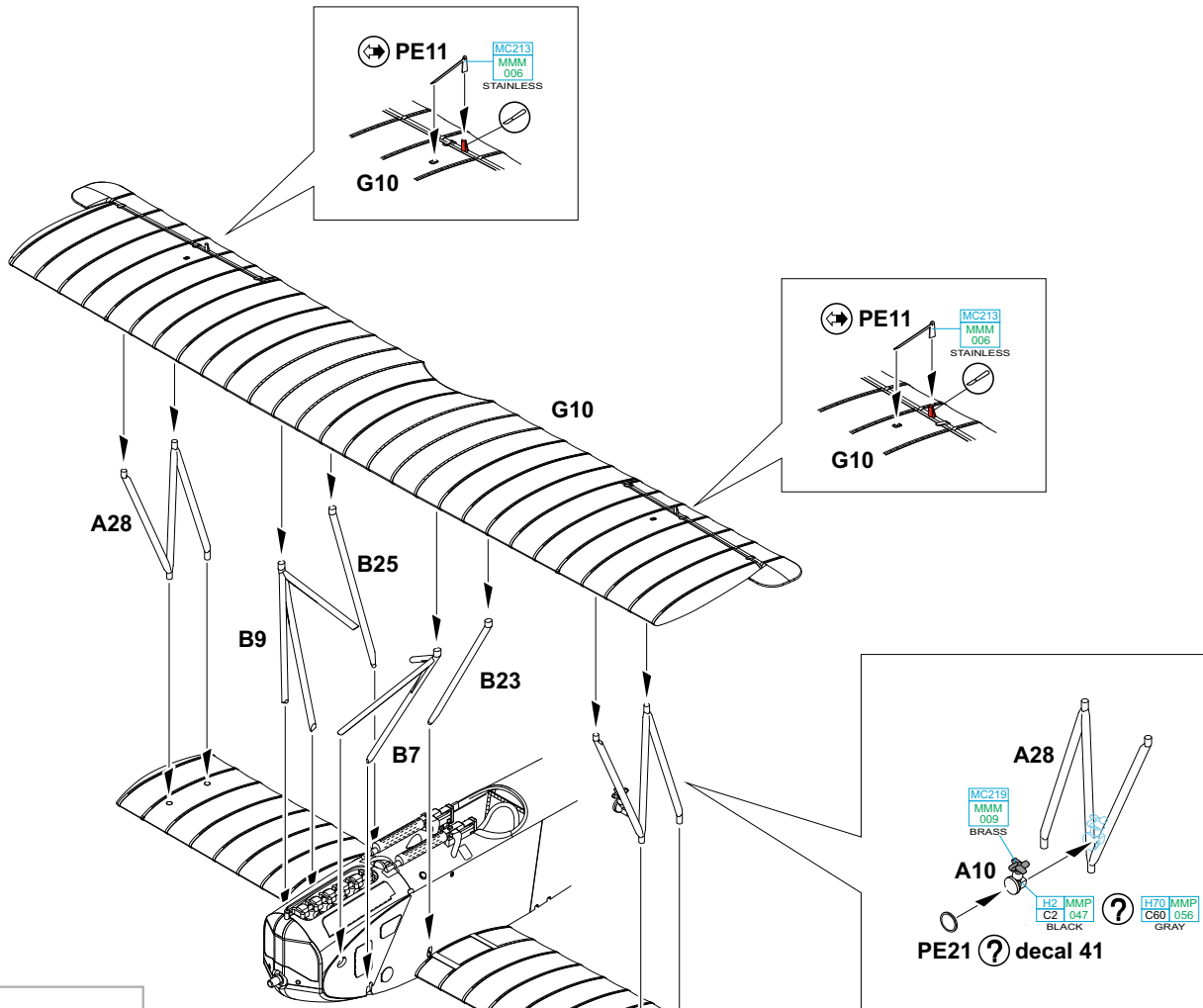
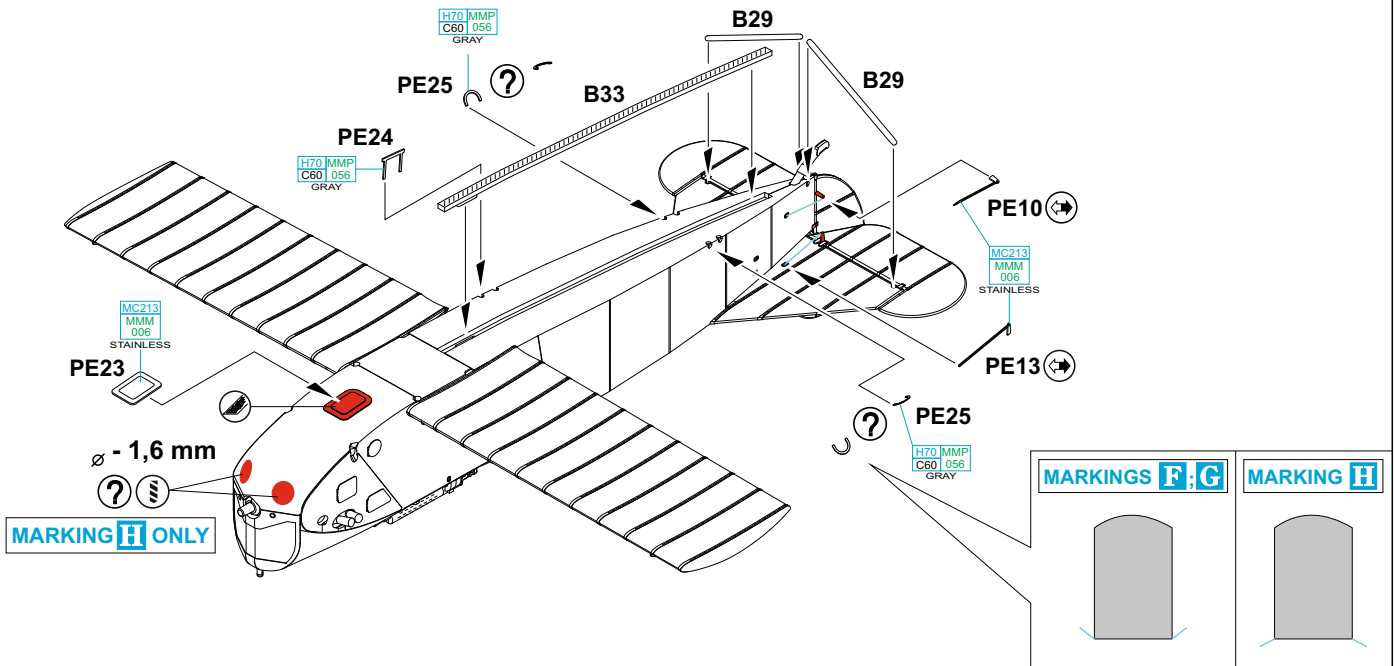

B18 - MARKINGS F, G

B21 - MARKING H

B18 ? B21

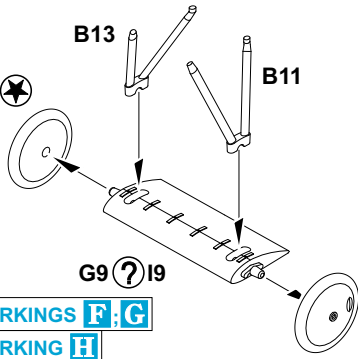

G9 - MARKINGS F, G

I9 - MARKING H

B18 ? B21

B18 - MARKINGS F, G

B21 - MARKING H

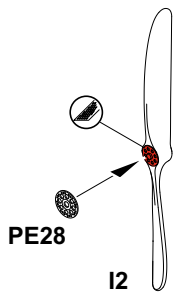

PE28

I2

I2 - MARKING H

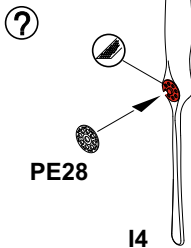

PE28

I4

I4 - MARKINGS F, G

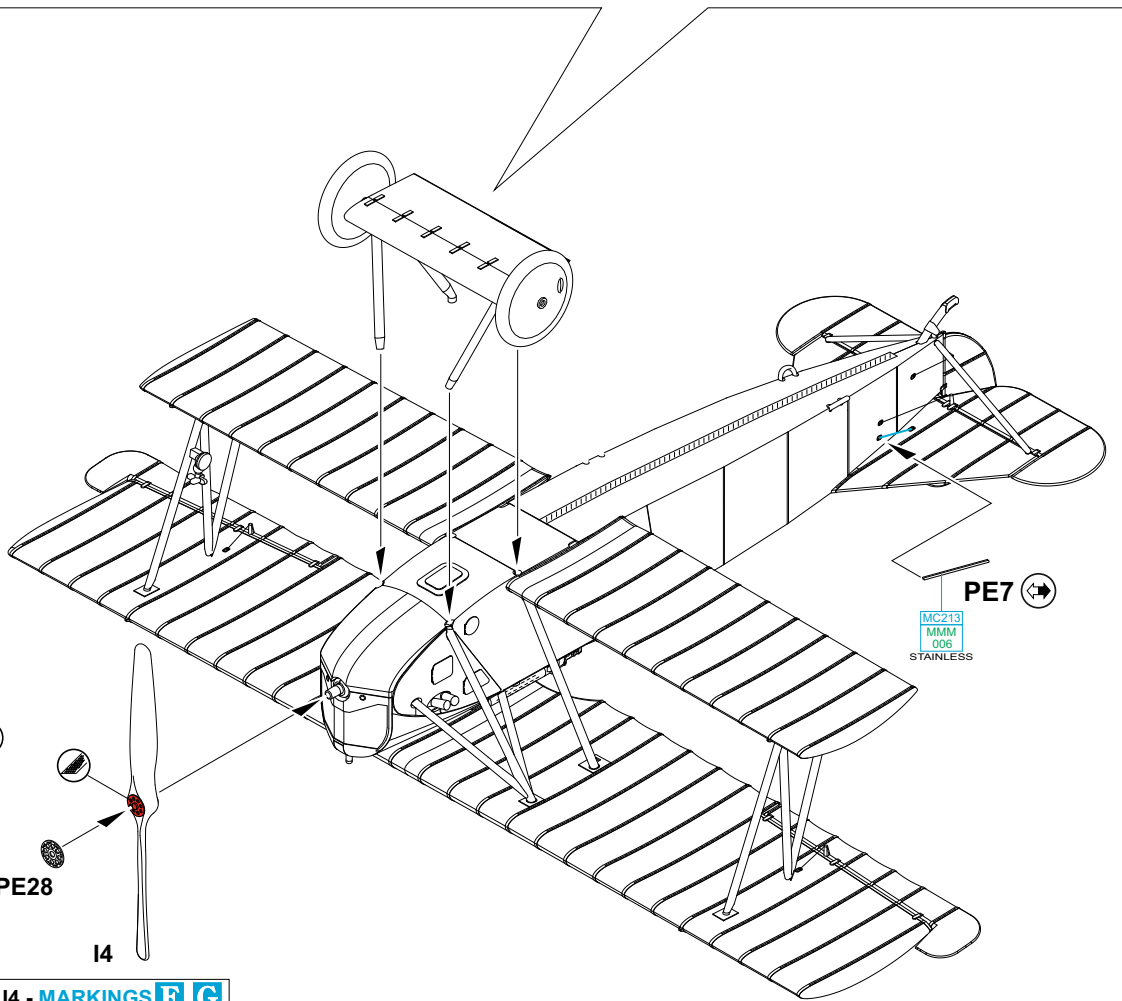

PE7

MC213
M3MM
006
STAINLESS

2 pcs.
B18 ? B21

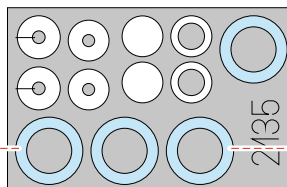

2 pcs.
B18 ? B21



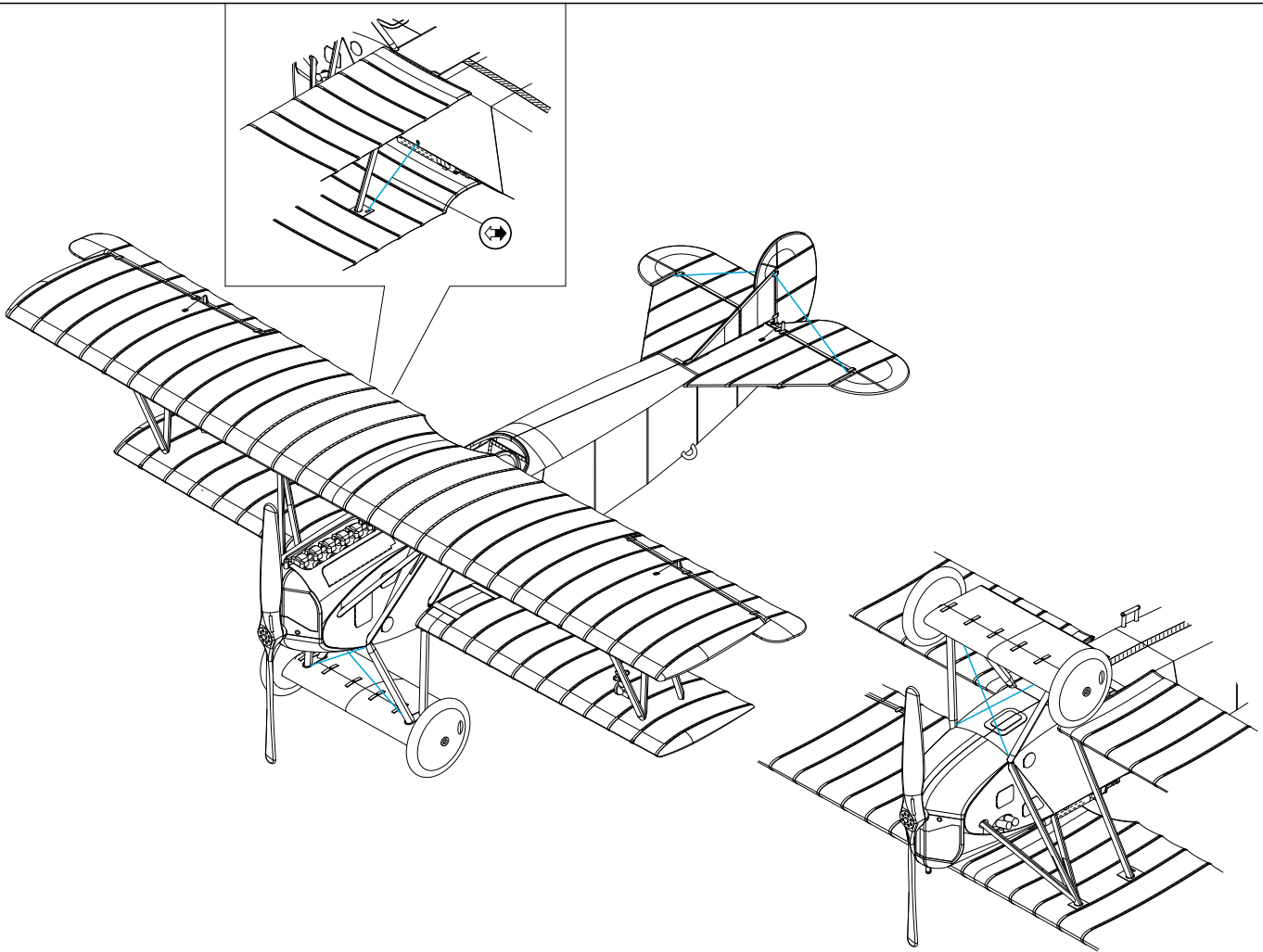

Albatros D.V / D.Va

RIB STRIPES

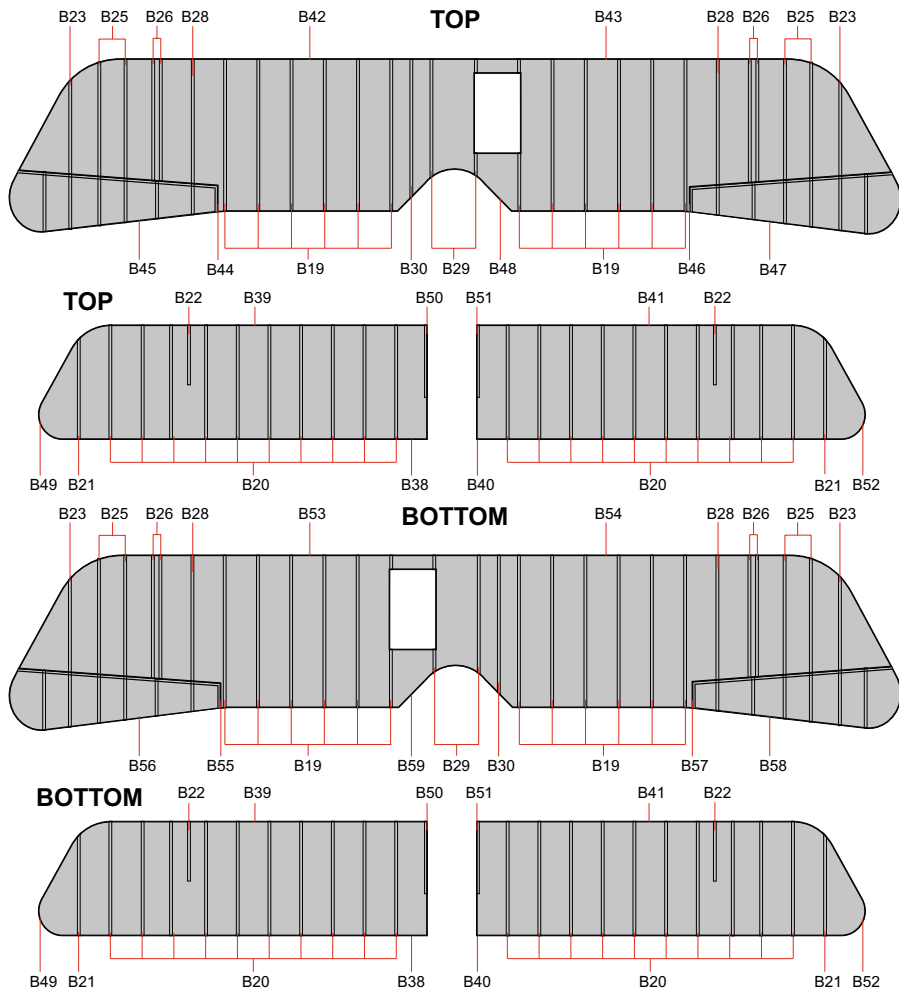

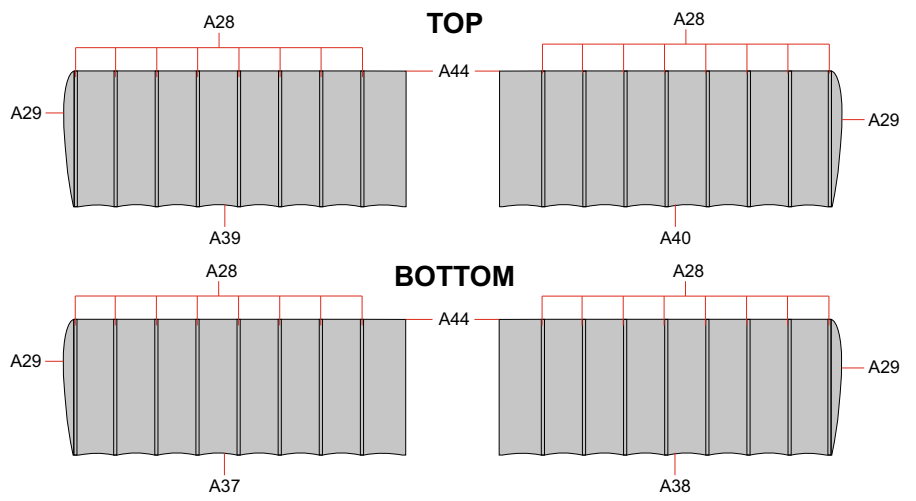
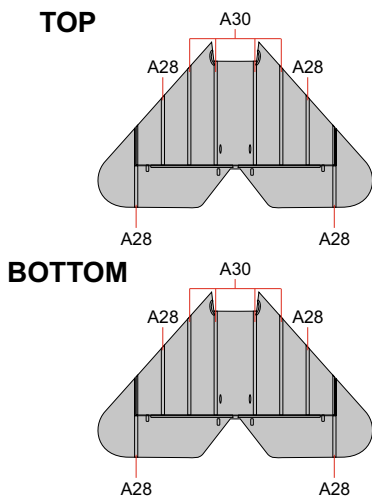
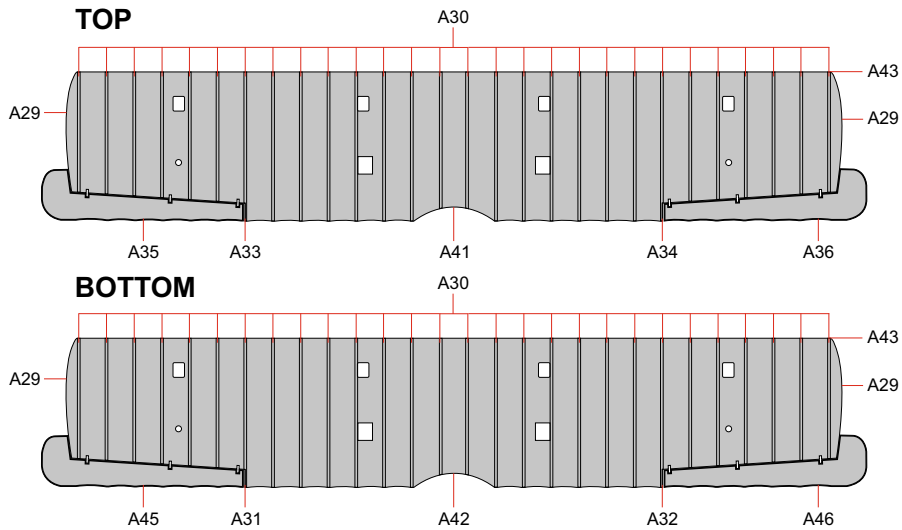

MARKING  ONLY

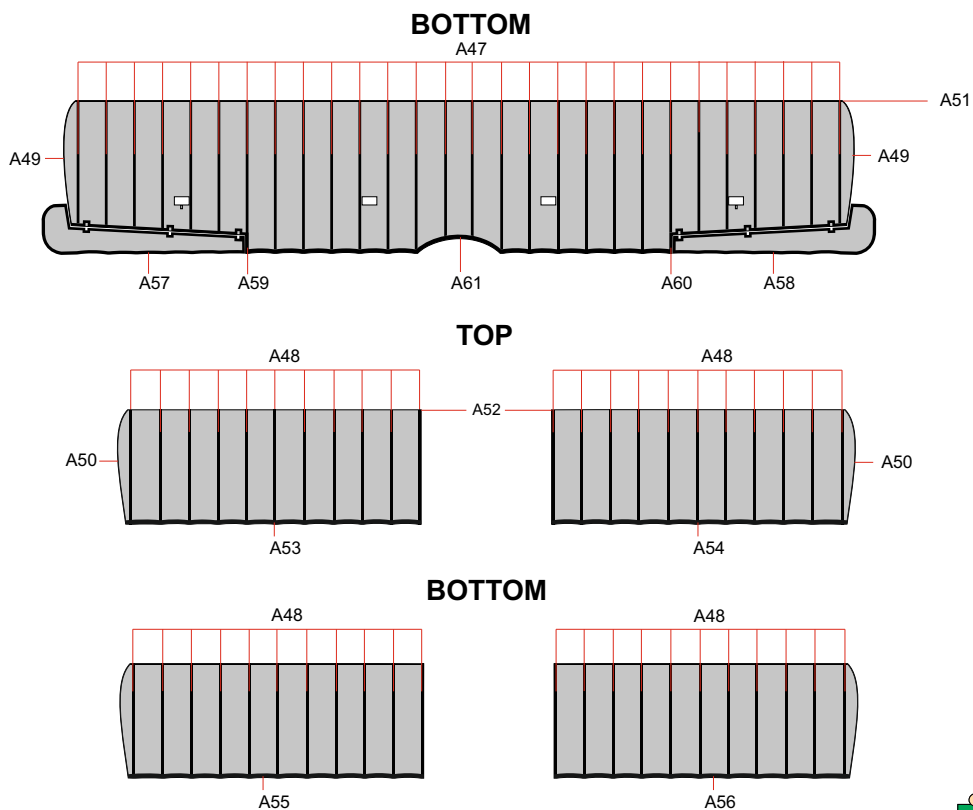

A Albatros D.V Jasta 37, Wasquehal airfield, France, July 1917

Lieutenant Ernst Udet was transferred from Jasta 15 to Jasta 37 at his own request on July 26, 1917. This posting came at his own request, since several of his old comrades from his days at Kampfeinsitzer Kommando were now serving with Jasta 37. This silver painted Albatros D.V was supposedly his first plane in Jasta 37, and all known photos show it with an immaculate overall finish. The black-and-white striped tail was the unit marking of Jasta 37, retained until the end of the war, but it is not clear whether the light stripes on this aircraft were white or silver. The silver colour was an overall finish applied to the plane, the metal cowlings and spinner were painted black and there was a black stripe applied to the wheel hub, on this plane (also on the inner wheel covers). The "LO" marking was placed quite close to the cockpit. The military number of this machine is unknown, as well as its eventual fate.

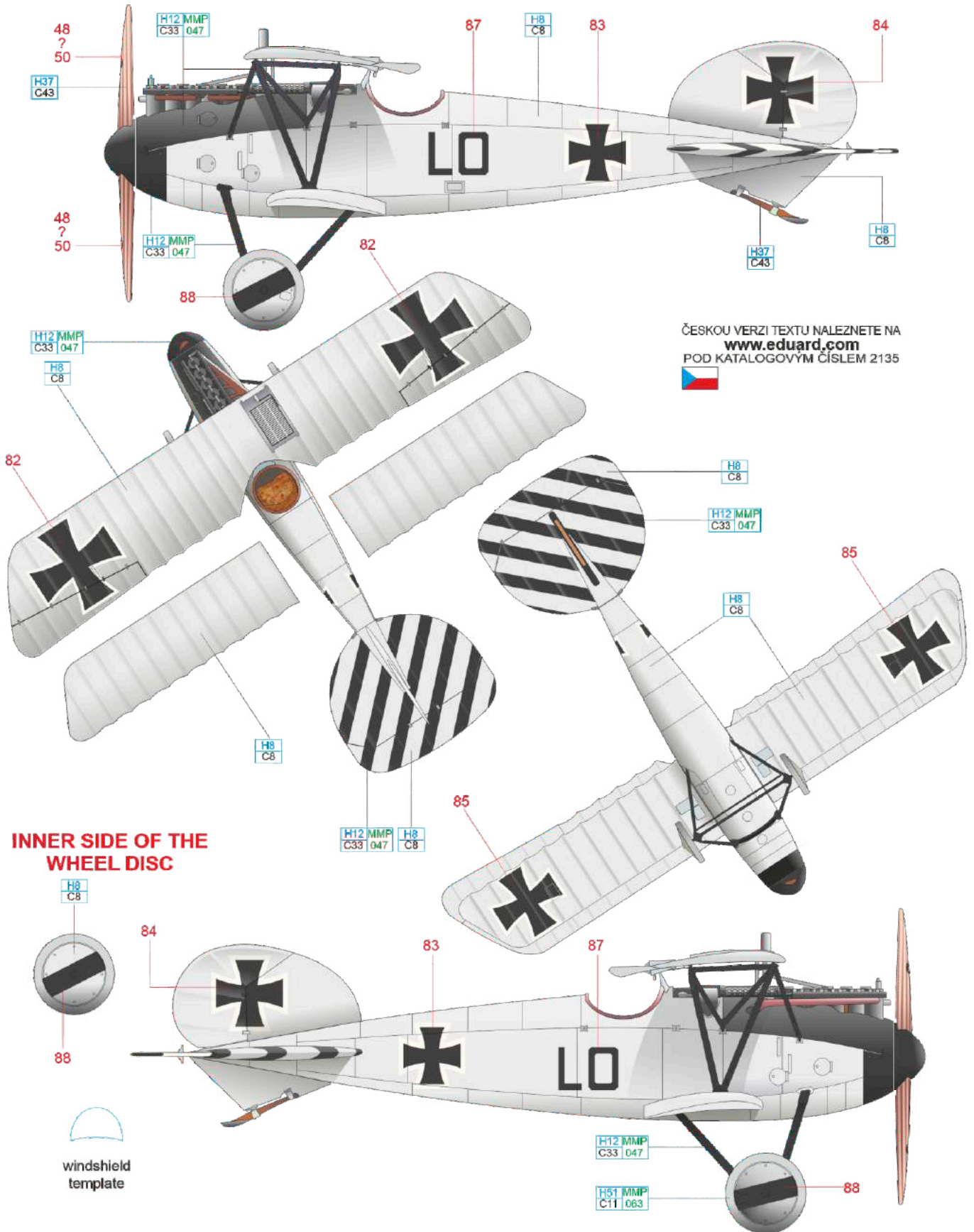

ČESKOU VERZI TEXTU NALEZNETE NA
www.eduard.com
 POD KATALOGOVÝM ČÍSLEM 2135

INNER SIDE OF THE WHEEL DISC

BLACK	H12 MMP C33 047	GRAY	H51 MMP C11 063	WOOD BROWN	H37 C43	SILVER	H8 C8
-------	-----------------	------	-----------------	------------	---------	--------	-------

B Albatros D.V, 4476/17, Jasta 37, Phalempin Airfield, France, September 1917

Udet's silver Albatros D.V was followed by a second aircraft of the same type that appeared in a less spectacular finish. Albatros D.V 4476/17 retained its wooden fuselage factory finish, with just the "LO" marking applied, this time located a bit closer to the fuselage cross. The personal marking received the addition of a white outline to give it a three-dimensional appearance here. For some time, a telescopic gunsight was fitted, as well as larger windscreen. None of these features were seen again on any of his later aircraft known. Quite short Udet certainly did not need a tall windscreen. The wings of this aircraft were covered in five-colour aircraft fabric (Flugzeugstoff), on both surfaces. Again, the fate of this plane is unknown. It was either destroyed in a crash or handed over to a new pilot and re-painted, both these cases were quite common.

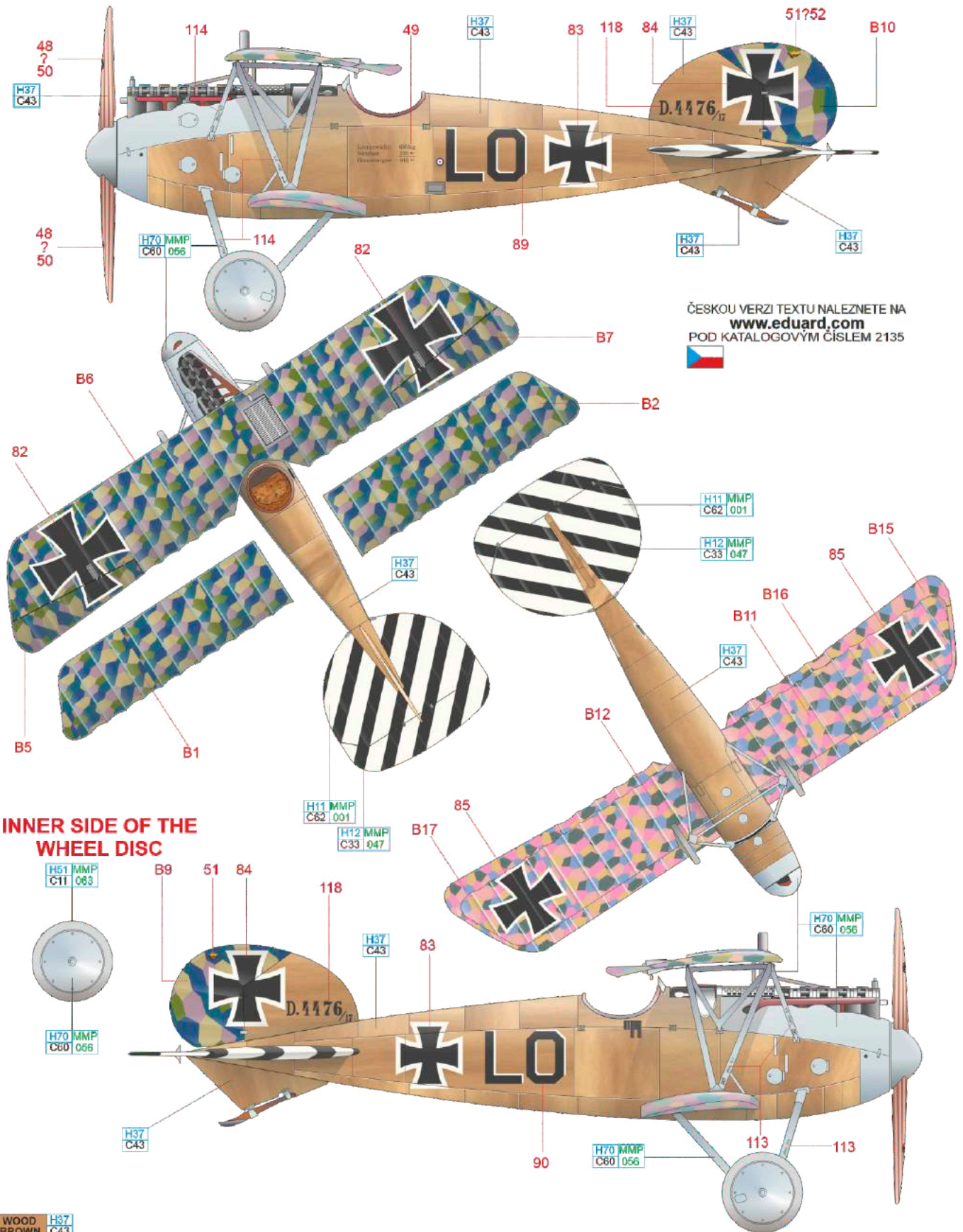

ČESKOU VERZI TEXTU NALEZNETE NA
www.eduard.com
 POD KATALOGOVÝM ČÍSLEM 2135

INNER SIDE OF THE WHEEL DISC

WOOD BROWN	H37 C43	GRAY	H51 MMP C11 063	GRAY	H70 MMP C60 056	BLACK	H12 MMP C33 047
WHITE	H11 MMP C62 001						

C Albatros D.Va, Jasta 37, Wynghenge Airfield, France, late 1917/early 1918

Udet was named commander of Jasta 37 on November 7, 1917, after the previous Jasta commander Oblt. Kurt Grasshoff has been posted away to lead Jasta 37. In his new position Udet flew this black-fuselage D.Va during the winter of 1917/18. The chevron marking on the nose was applied in unusual position. On all his three known Albatros fighters in this unit the "LO" was applied in an angular manner. The lower wings of this aircraft were covered in five-colour aircraft fabric (Flugzeugstoff), while the upper surfaces were most likely painted in the usual two-tone camouflage. This mix was seen on at least one other Jasta 37 Albatros fighter, too. Two white stripe markings can be seen on the leading edge of the upper wing in photos, and we have interpreted this as two chevrons similar to the ones on the nose. Unfortunately, no clear view showing the top surface of the upper wing is known. One day, possibly during an icy winter day during February 1918, this aircraft flipped, most likely during a failed landing attempt. Udet would remain with Jasta 37 until March 8, 1918, when he was posted away to join the most famous German fighter units of them all, Manfred von Richthofen's Jasta 11.

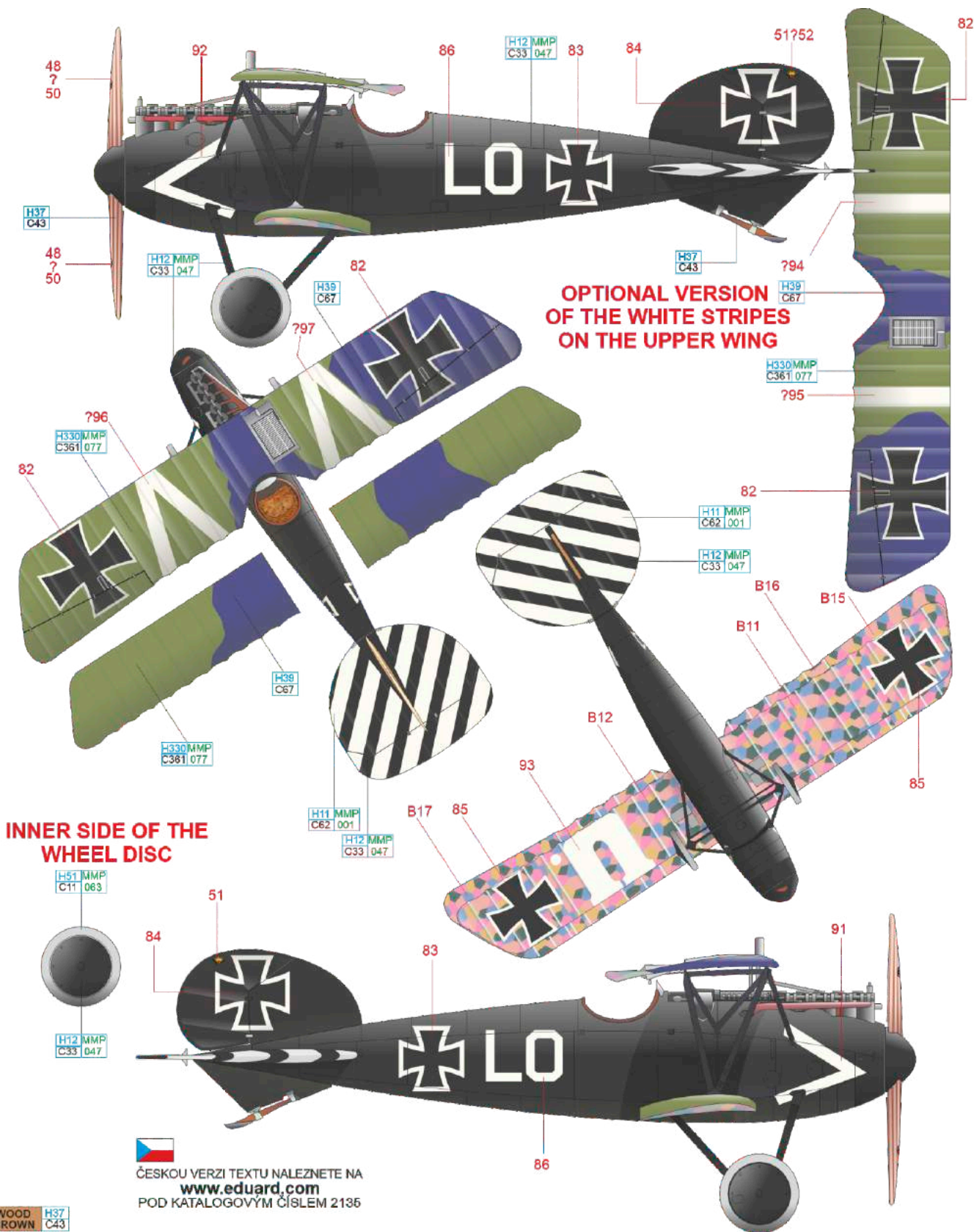

WOOD BROWN H37 C43

WHITE H11 MMP C62 001

GRAY H51 MMP C11 063

GREEN H330 MMP C361 077

VIOLET H39 C67

BLACK H12 MMP C33 047

eduard

D Fokker Dr.I, 586/17, Jasta 4, Airfield "La Ferme Puisieux" near Laon, France, late May 1918

After a few short weeks of flying with Jasta 11, Udet had developed otitis media (ear infection) and was sent home to Munich on April 8, 1918 to recover. He had returned to JG I on May 22 and was appointed as commander of Jasta 4. Previously, Jasta 6 ace Lt. Hans Kirschstein had acted as deputy commander of Jasta 4, but he returned to Jasta 6 when it re-equipped with the Fokker D.VII on May 15, 1918. Udet overtook Kirschstein's Dr.I painted with oblique black and white stripes on the fuselage and upper wing to throw off the aim of a pursuer. He called his planes in that marking "Die optische Täuschung" (the optical illusion). The stripes on the tail were the unit markings of his parent Jasta 6. Udet just added the famous "LO" to the fuselage sides to personalize the plane, but it would only serve him for a short time. The "O" of his personal marking become rounded with this aircraft, more changes to the design of this monogram would follow soon. At some point in late May or early June, one of the cylinders of the rotary engine detached while the engine was running, tearing apart the engine cowling and damaging the upper wing. The plane was written off. Such things happened to Oberursel engines... National insignias on the wings were changed most likely during the early days of the June 1918.

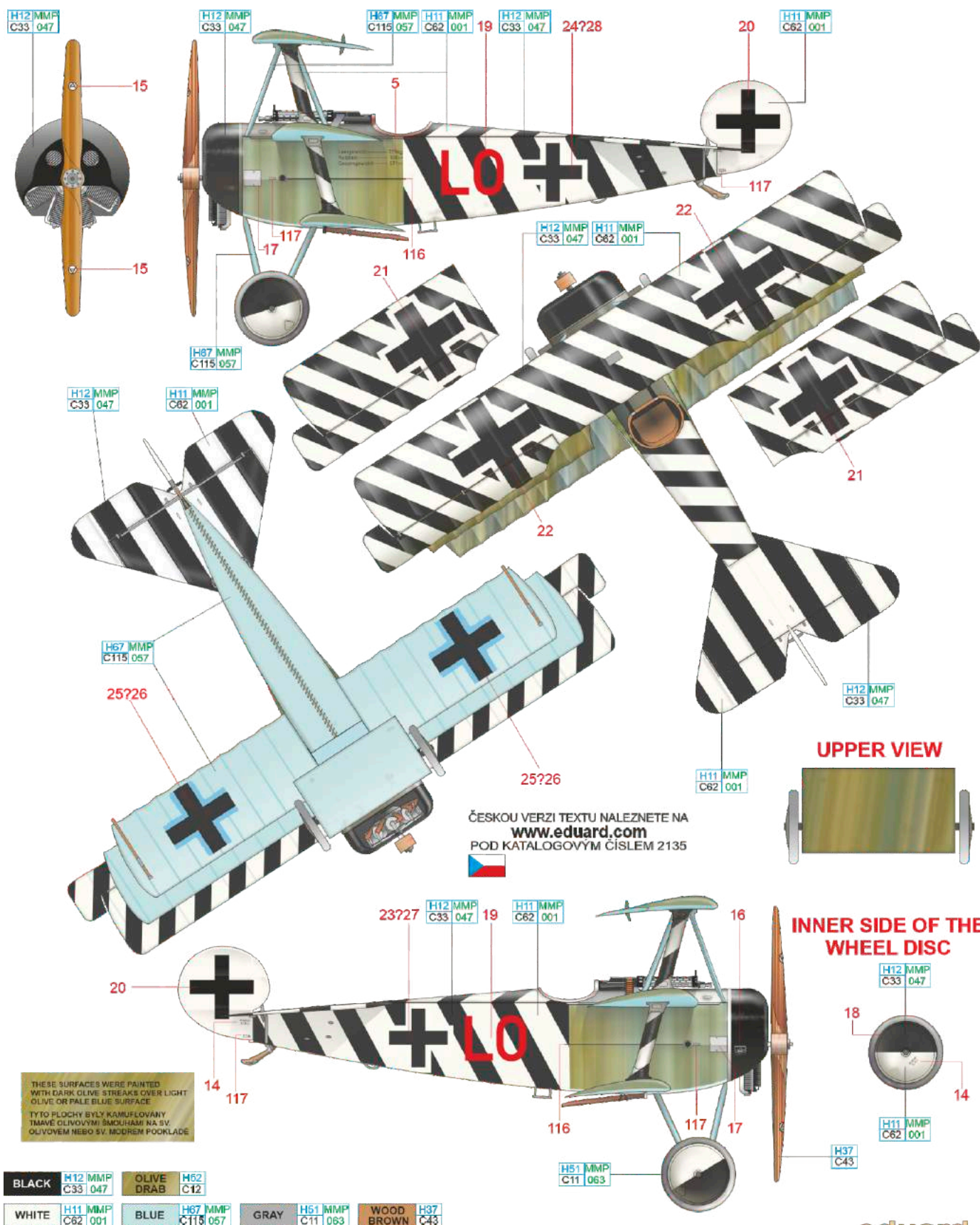

ČESKOU VERZI TEXTU NALEZNETE NA
www.eduard.com
 POD KATALOGOVÝM ČÍSLEM 2135



THESE SURFACES WERE PAINTED WITH DARK OLIVE STREAKS OVER LIGHT OLIVE OR PALE BLUE SURFACE
 TYTO PLOCHY BYLY KAMUFLOVANY TMAVĚ OLIVOVÝMI ŠMOURAMI NA SV. OLIVOVĚM NEBO SV. MODRÉM PODKLADĚ

BLACK	H12 MMP C33 047	OLIVE DRAB	H62 C12
WHITE	H11 MMP C62 001	BLUE	H67 MMP C115 057
		GRAY	H51 MMP C11 063
		WOOD BROWN	H37 C43

E Fokker Dr.I 593/17, Jasta 4, Beugneux-Cramoiselles Airfield, France, early June 1918 Jasta 4

Jasta 4 converted to the Fokker Dr.I on April 20, 1918 while Udet was away from the front. This aircraft was apparently a reserve Triplane that Udet used as a replacement of the striped Triplane, damaged beyond repair. Photos show the aircraft in use at Jasta 4 in early June 1918 at Beugneux-Cramoisselle airfield. The chevron he had used previously on his Albatros D.Va at Jasta 37 re-appeared on this Dr.I, now painted onto the horizontal tailplane. The outline of his „LO!“ marking had only been applied as a chalk outline on the fuselage sides, as a guide for the painter who would complete the marking later. No photo showing the „LO!“ marking properly applied to this aircraft is known. Apparently, not much effort was made to personalize it, as Udet and his men were hoping to get the new D.VII soon.

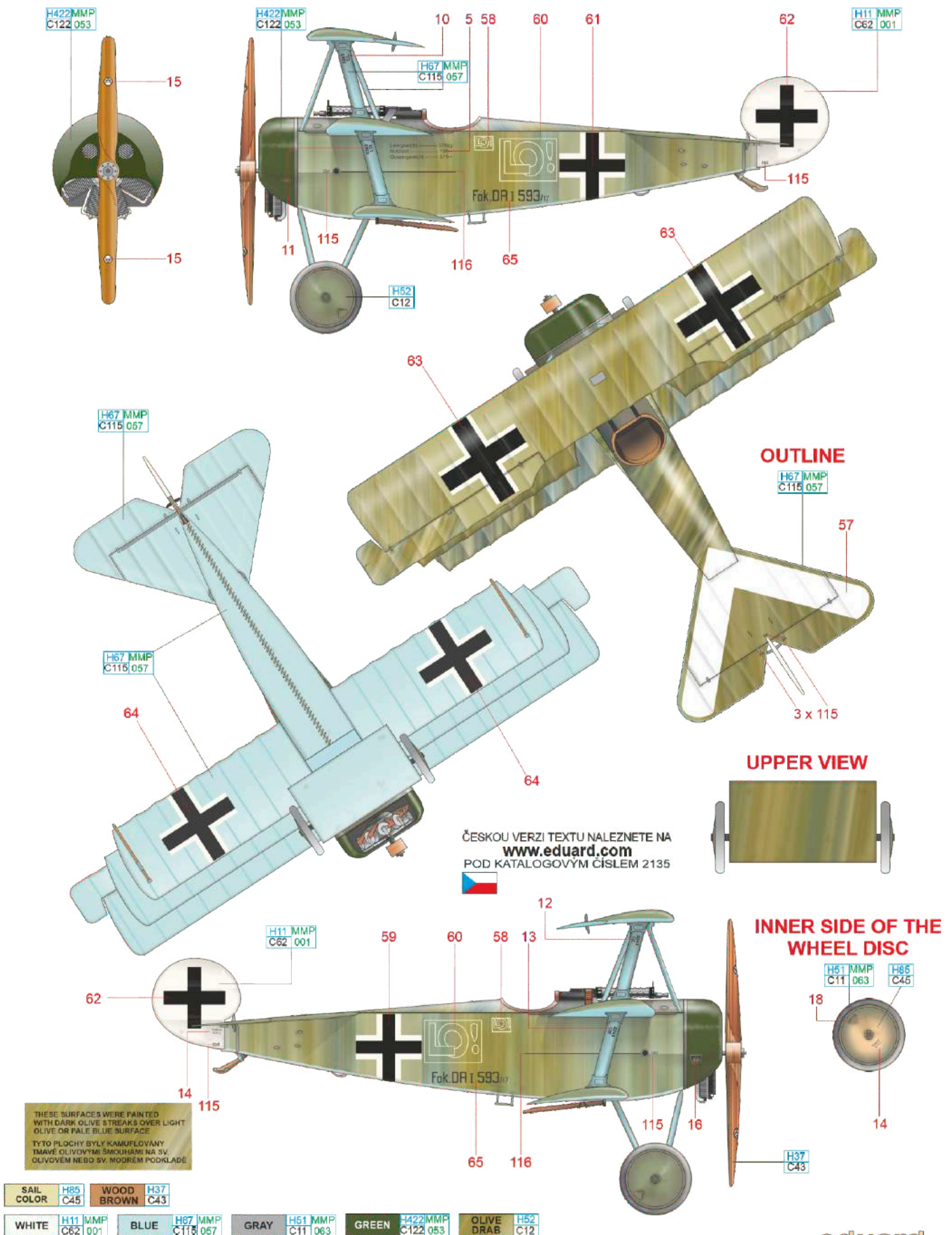

F Fokker D.VII (O.A.W.), 20xx/18, Jasta 4, Beugneux-Cramoiselles Airfield, France, June 1918

Jasta 4 finally received the new Fokker D.VII on June 13, 1918. All these were license built O.A.W. machines, replacing their out-dated Triplanes. Immediately, a new unit marking, consisting of black noses, wheel covers and struts, was introduced. This marking was certainly inspired by the black fuselages of Jasta 37. Udet was named the acting commander of Jagdgeschwader "Von Richthofen" on June 18, and although he only held this position for one day, it was probably enough of an event to mark his plane in a more recognizable style. The fuselage was supposedly fully painted red, possibly as a reference to his previous service at Jasta 11. The wings were striped in red and white, similar to the Kirschstein's plane, but with the stripes slanted in the opposite direction. The number of stripes is usually thought to be higher than we show here, but the famous photo of this plane is heavily retouched. Close inspection reveals that only the stripe going through the right-wing cross is original. All other stripes visible on the photo were simply drawn into it! By comparison with another tiny photo, shown in a TV documentary, we have come up with our interpretation of the upper wing stripe layout. The nose and wheel covers may have retained the black Jasta 4 unit markings or were painted red as well. Available photos leave the possibility of both these options. This beautiful plane was lost on June 29, 1918 in combat with a French Breguet Br.14 observation plane.

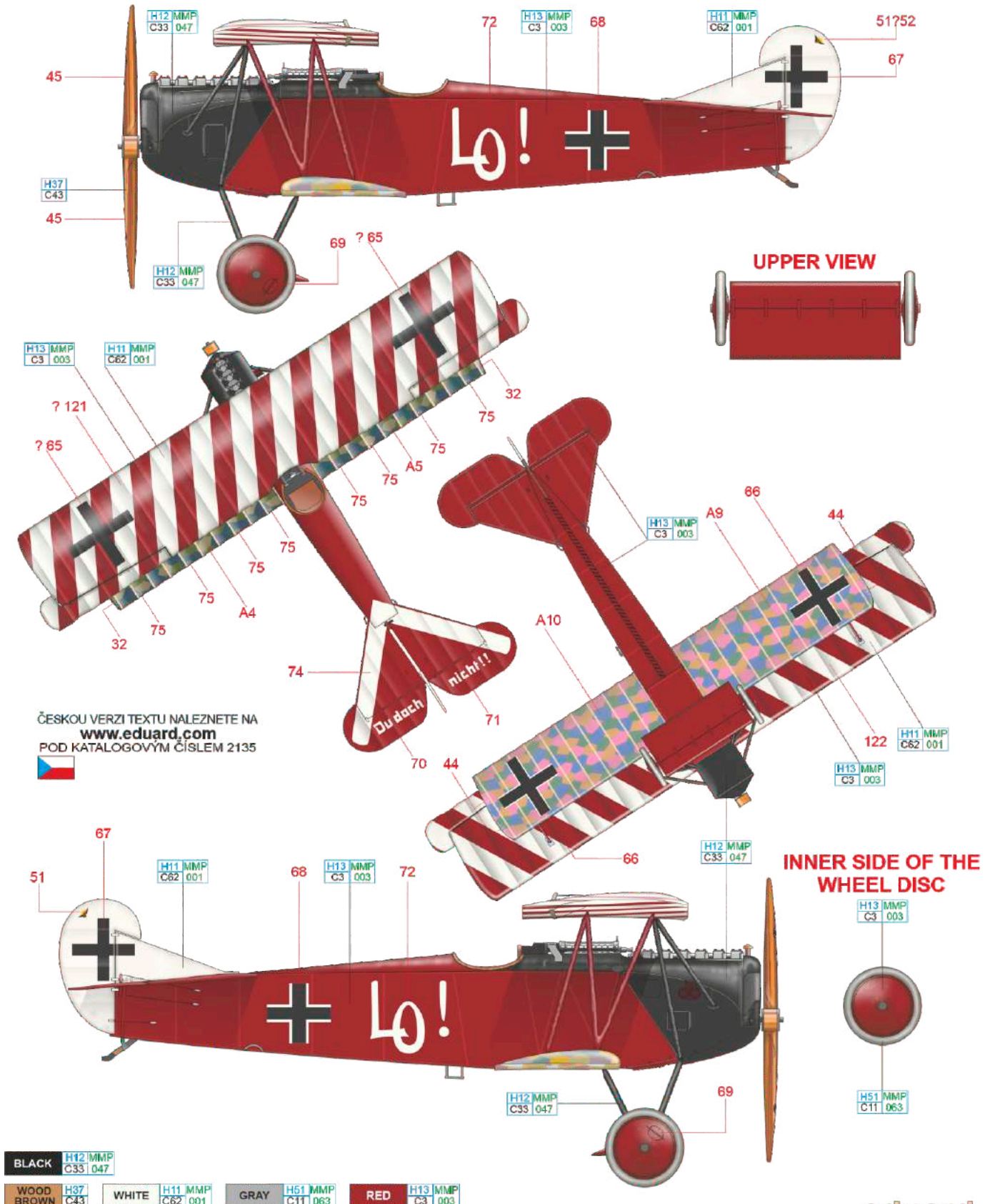

H Fokker D.VIIF, 4253/18, Oblt. Ernst Udet, Jasta 4, Beugneux, France, July 1918

The all-red BMW powered Fokker-built mount of Ernst Udet reached Jasta 4 in late July 1918. Udet flew this plane with great success in August 1918, being credited with 20 victories in just 20 days. Due to unknown reasons the upper wing of his mount was changed for one taken from an O.A.W.-built D.VII. Udet flew this D.VII F without the upper cowling to improve the cooling of the engine and ammunition. The Lo! painting on the fuselage was there, like with all his other planes, to honour his fiancée Eleonor Zink, which he married in 1920. The famous "Du doch nicht!!" inscription was not present on this aircraft.

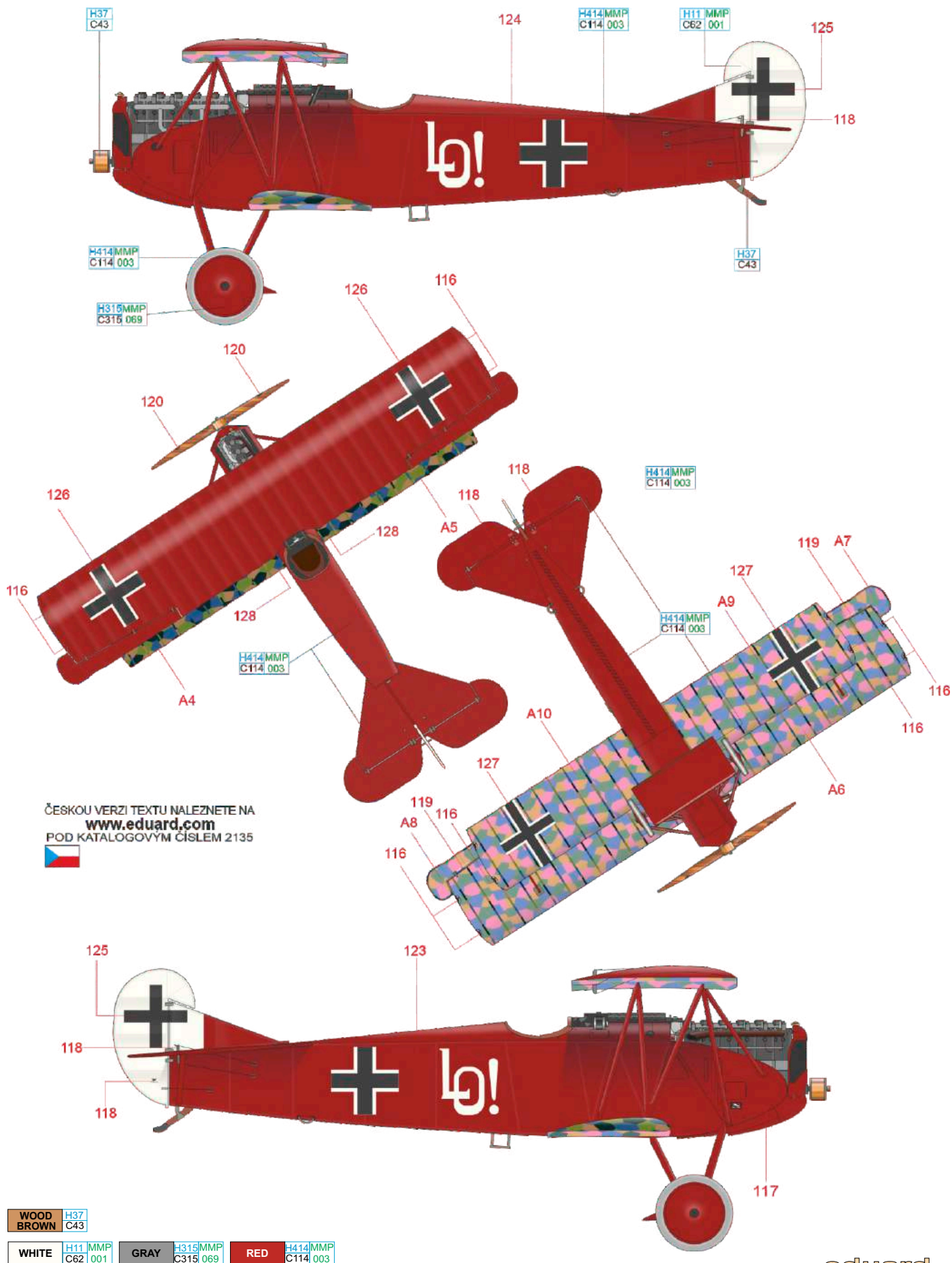

ČESKOU VERZI TEXTU NALEZNETE NA
www.eduard.com
 POD KATALOGOVÝM ČÍSLEM 2135



WOOD BROWN H37 C43

WHITE H11 MMP C62 001

GRAY H315MMP C315 069

RED H414MMP C114 003

The first volume in a landmark series of the Great War aviation books with detailed markings of German fighter planes is out!

The first volume of a series of books dealing with the colours of German WW I fighter aeroplanes offers an insight into the research process of looking for the true colours of the Fliegertruppe fighter aircraft.

A detailed presentation covering the author's long term research, conducted mainly in the 1970s and 80s, sheds light on the process of uncovering long lost documentation revealing the true colours of the aircraft and recounting the adventures of their pilots. The book contains 58 colour profiles, many of these not seen before, while others correct previous misinterpretations of markings. Moreover, some 223 photographs and 61 reproductions of documents are published here.

Renowned historian and author Bruno Schmäling completed this book with the cooperation of fellow researcher Jörn Leckscheid, a long-time friend of Eduard.



The book has been published by Aeronaut Books (USA) and is available worldwide from the Amazon.com and its local representations.

More about publisher at:
www.aeronautbooks.com