

AH-1G Cobra 'Early Tails over Nam'



Americké letectvo začalo záhy po zapojení se do války ve Vietnamu používat vrtulníky jako nosiče ofenzivní výzbroje. Již v letech 1962-63 podporovaly vrtulníkové výsadky palbou z kulometů, kanonů či raketometů v polních podmínkách vyzbrojené vrtulníky UH-1A. Úspěšné použití takto vyzbrojených vrtulníků ukázalo potřebu nového jednoúčelového útočného stroje s účinnou výzbrojí, co nejmenšími rozměry a velkou odolností proti poškození. Protože americká armáda měla o takový stroj enormní zájem, firma Bell zahájila vývoj takového stroje ve své režii. První projekt na základě typu Bell 47 nebyl úspěšný. Handicapoval ho zejména slabý pístový motor. Nový projekt firmy, označený D-262 postupně vyzrál do podoby označené model 209. Model 209 přebíral část konstrukčních řešení z vrtulníku UH-1C (ližiny podvozku, rotor, nosník ocasního rotoru apod.), měl však nový trup s kabinou pro dva členy osádky a s pylony pro podvěšenou výzbroj. Když armáda USA vypsala v roce 1965 soutěž na nový bitevní vrtulník, Bell model 209 ji s přehledem vyhrál. Hned v následujícím roce armáda objednala nejprve dva předseriové a pak stodeset seriových vrtulníků s armádním označením AH-1G Cobra. Další objednávky následovaly. Pro co nejrychlejší nasazení Cober ve Vietnamu vzniklo přeškolenací středisko NETT (New Equipment Training Team) v jihovietnamském Vung Tau. První jednotkou nasazenou do boje na nových strojích byla 334. rota operující z Bien Hoa. Urychleně byly vyzbrojovány další jednotky. V průběhu bojů ve Vietnamu byly postupně zapracovány na vyráběných vrtulnicích poznatky a požadavky letců. První vrtulníky měly vyrovnávací rotor vlevo, pozdější vpravo, byly montovány zesílené ližiny podvozku, příďovou věž TAT-102 s jedním rotačním kulometem Minigun nahradila věž M-28 s Minigunem a granátometem (nejčastěji). Na závěsníky byla zavěšována pestrá výzbroj od různých raketových bloků, přes pouzdra s kulometry Minigun až po komplet M-35 (kanon Vulcan s nábojovými schránkami). Záleželo na úkolu, který měl vrtulník plnit a také na tom, jakou výzbroj pilot preferoval. V roce 1972 se na vrtulnicích objevily deflektory výtokových plynů jako reakce na tepelně naváděné střely ve výzbroji komunistické vietnamské armády a Vietkongu. Ve Vietnamu se Cobry nesporně osvědčily. Používaly je nejen vrtulníkové jednotky armády, ale i jednotky US MARINES. US MARINES bylo také s AH-1G spokojeno, ale pro provoz nad mořem a lodích požadovalo dva motory, což vedlo k vývoji dvoumotorových verzí, první z nich byla AH-1J. AH-1G Cobra byly exportovány jen do Španělska a Izraele. Ve Španělsku je používalo námořnictvo, v Izraeli měly AH-1G problémy s prašným a horkým podnebím. Izrael potřeboval vrtulníky pro boj s tanky a proto další objednávky byly směřovány na protitankové verze AH-1Q/S. Na tyto verze bylo také přestavěno mnoho amerických AH-1G, včetně strojů stažených z Vietnamu. Koncepce AH-1G Cobra se stal etalonem pro bitevní vrtulník. Další verze tohoto vrtulníku létají dodnes jak v USA, tak ve výzbroji mnoho jiných armád.

TTD:

průměr hl. rotoru: 13,4 m, délka trupu: 13,5 m, průměr vyrovnávacího rotoru: 2,6 m, max. rychlost: 276 km/h, dostup: 3871 m, dolet: 580 km



Soon after its engagement in the Vietnam War the US Air Force started to use helicopters as offensive weapons platforms. Even during 1962-63 period field modified UH-1A helicopters supported the troops' landing with machineguns, cannons and rockets. The success of such equipped helicopters showed the need of a new, single purpose attack machine of the smallest possible dimensions, equipped with effective firepower and high damage resistance. Bell Company started to develop of specified helicopter on their expenses since the US Army had immense interest in such machine. The first project based on type Bell 47 was not successful. Its main downfall was a weak piston engine. The new project designated D-262 grew into the late appearance designated as model 209. The model 209 took over some of the structural solutions from UH-1C helicopter (undercarriage skis, main rotor, tail boom, etc.) but featured new fuselage that housed cockpit for crew of two and stub wings for carrying external armament. When in 1965 the US Army issued a specification calling for new attack helicopter, Bell model 209 was a clear winner. The very next year the US Army ordered, initially two pre-production machines and then 110 production helicopters under army designation AH-1G Cobra. Additional orders followed the original one. To speed up the Cobra deployment into Vietnam a NETT (New Equipment Training Team) training centre was founded in Vung Tau in South Vietnam. The first unit that flew the new machines in combat was the 334th platoon based at Bien Hoa. Other units were rapidly equipped with Cobras. The knowledge and pilots' requirements during the fights in Vietnam were incorporated into the production of the helicopters. The first helicopters featured the tail rotor on the left side, later relocated to the right side, strengthened undercarriage skis were adopted, the original nose mounted TAT-102 turret with Minigun was replaced by M-28 turret equipped with Minigun and grenade launcher (most often). The stub wings were capable of carrying variety of weapons; from various rocket blocks, Minigun pods to M-35 pod (Vulcan cannon with ammunition boxes). All depended on the mission purpose and pilot's preferences. As a reaction to the heat seeking missiles used by the Vietnamese Army and the Viet Cong starting in 1972 the helicopters were equipped with exhaust gas deflectors. Cobras indisputable prove to be effective in Vietnam. They were used not only by US Army helicopter units but also by the US Marines that were also satisfied with AH-1G but for the shipboard and over sea operations which required a helicopter with two engines. This requirement led to the development of twin-engined version AH-1J. AH-1Gs were exported only to Spain and Israel. Cobras were used by the Spanish Navy. Israeli Cobras faced troubles with hot and dusty environment. Israel needed tank buster helicopters and therefore subsequent orders were placed for the anti-tank version AH-1Q/S. Plenty of the US AH-1Gs were modified to this version, including the machines withdrawn from Vietnam. The conception of AH-1G Cobra became a standard for attack helicopters. Subsequent versions of this helicopter are still in use not only in the USA but also in many other armies.

TTD:

Main rotor diameter: 13.4 m, Fuselage length: 13.5 m, Tail rotor diameter: 2.6 m, Max. speed: 276 kmh, Service Ceiling: 3,871 m, Range: 580 km

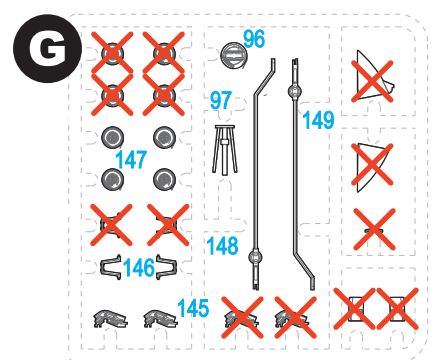
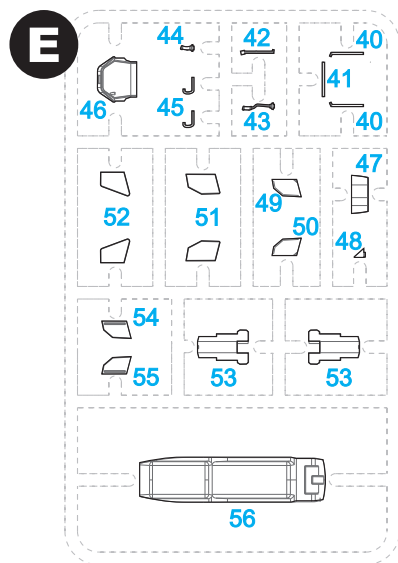
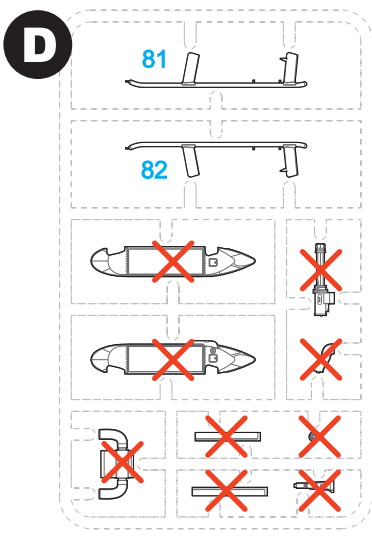
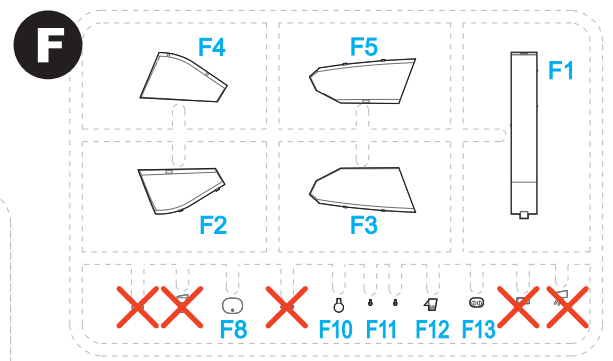
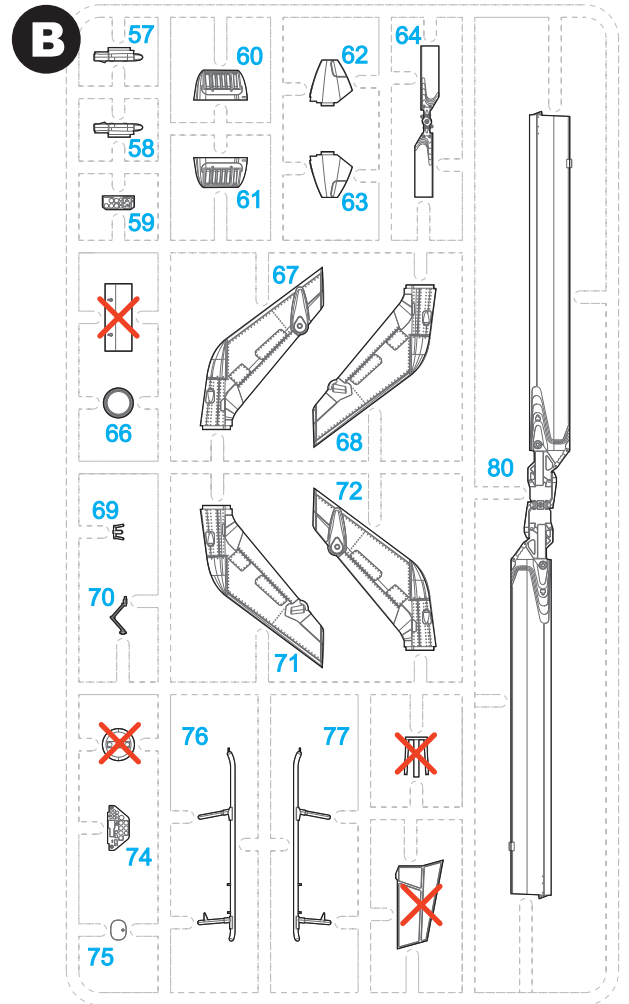
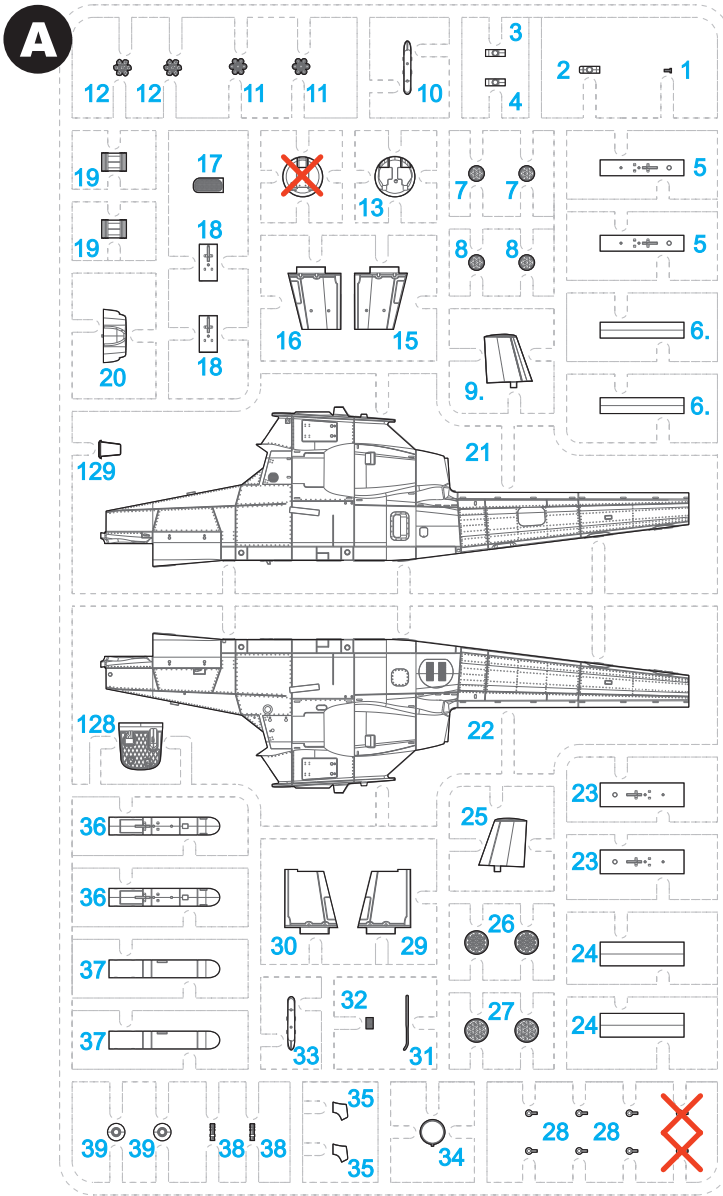

X - Not used

SYMBOLS

? MOŽNOST VOLBY
OPTIONAL
NACH BELIEBEN
OPTION

W POUŽÍŤ KYANOAKRYLÁTOVÉ LEPIDLO
INSTANT CYANOACRYLATE GLUE
ZYANOAKRYLÁTKLEBER
ADHÉSIF CYANOACRYLAT

B OHNOUT
BEND
BIEGEN
COURBER

H ZHOTOVIT NOVÉ
SCRATCH BUILD
FERTIGSTELLEN
ACHEVER

D ŘEZAT/VRTAT
CUT OFF/DRILL
ENTFERNEN
DETACHER

A GSI
colours code
NATRÍT
COLOUR
FARBEN
FEINDRE

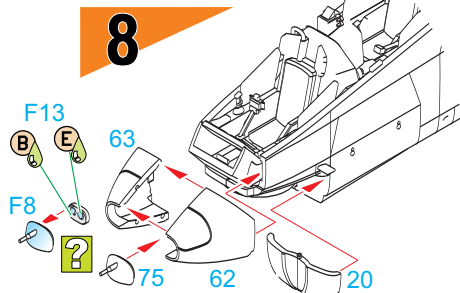
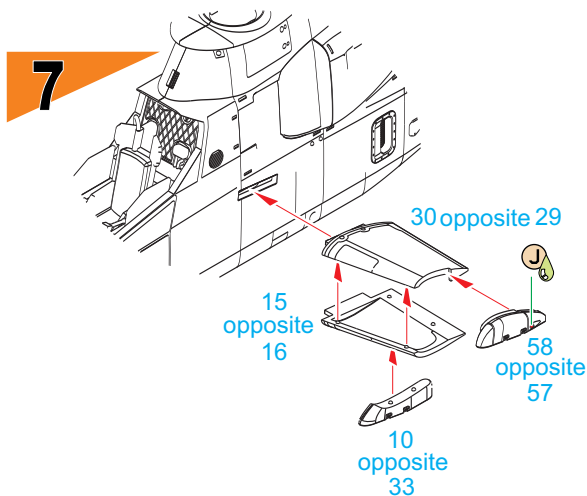
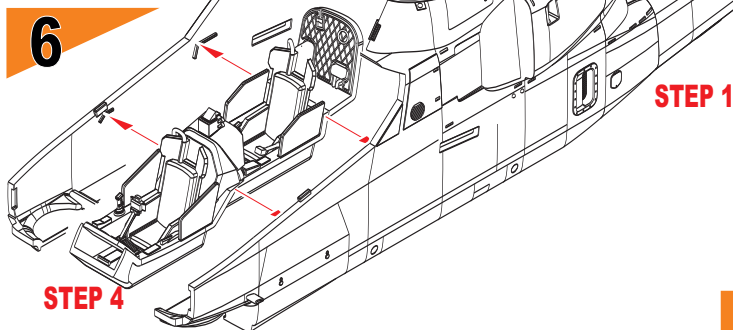
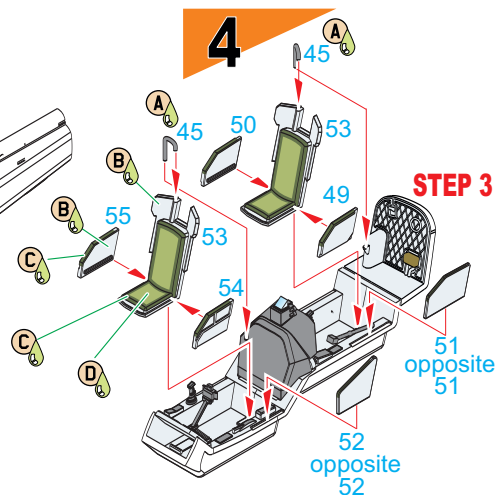
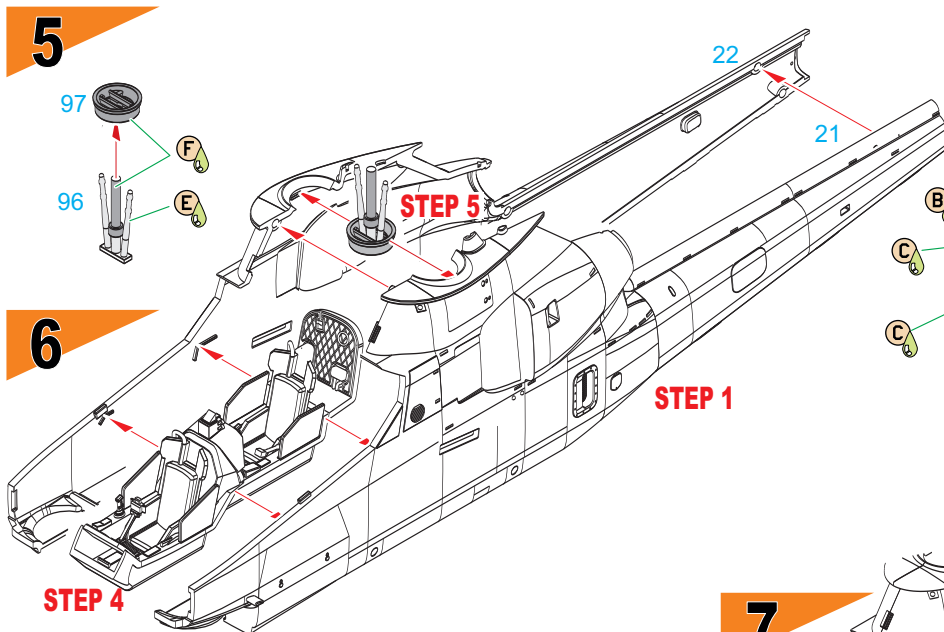
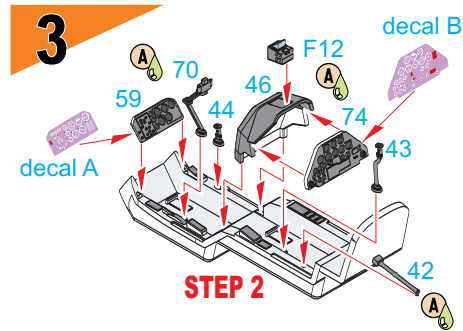
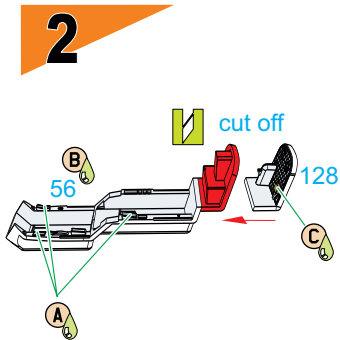
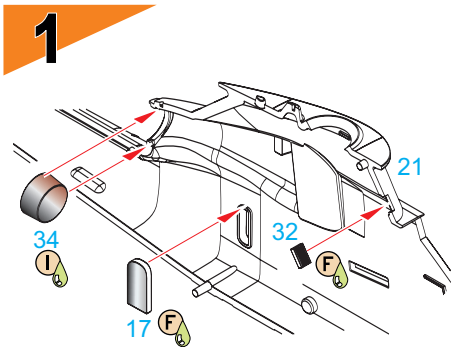

Note:
For schemes A,C - use parts F8, F13

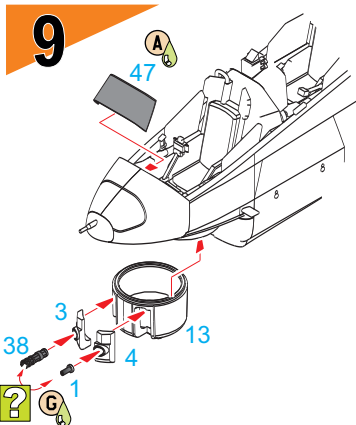

Note:
see camouflage schemes for
arrangement of the turret armament.

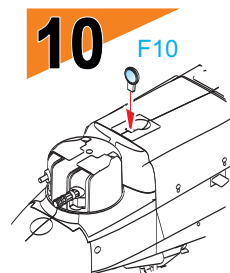

Barvy GUNZE/ GUNZE Colour No.

A	Černá / BLACK	H12/C33
B	Tm. racčí šedá / DK.GULL GRAY	H317/C317
C	Olivově zelená / OLIVE GREEN	H52/C12
D	Světle zelená / LIGHT GREEN	H26/C66
E	Hliník / ALUMINIUM	H8/C8
F	Ocelová / STEEL	H18/C28
G	Dělovina / GUNMETAL	H28/C78
H	Tmavá mosaz / DK.BRASS	MC219
I	Opálený kov / BURNT METAL	H76/C61
J	Červená čirá / CLEAR RED	H90/C47
K	Modrá čirá / CLEAR BLUE	H93/C50
L	Barva pneu / TIRE BLACK	H77/C137
M	Světle šedá / LT.GRAY	H21/C69

11

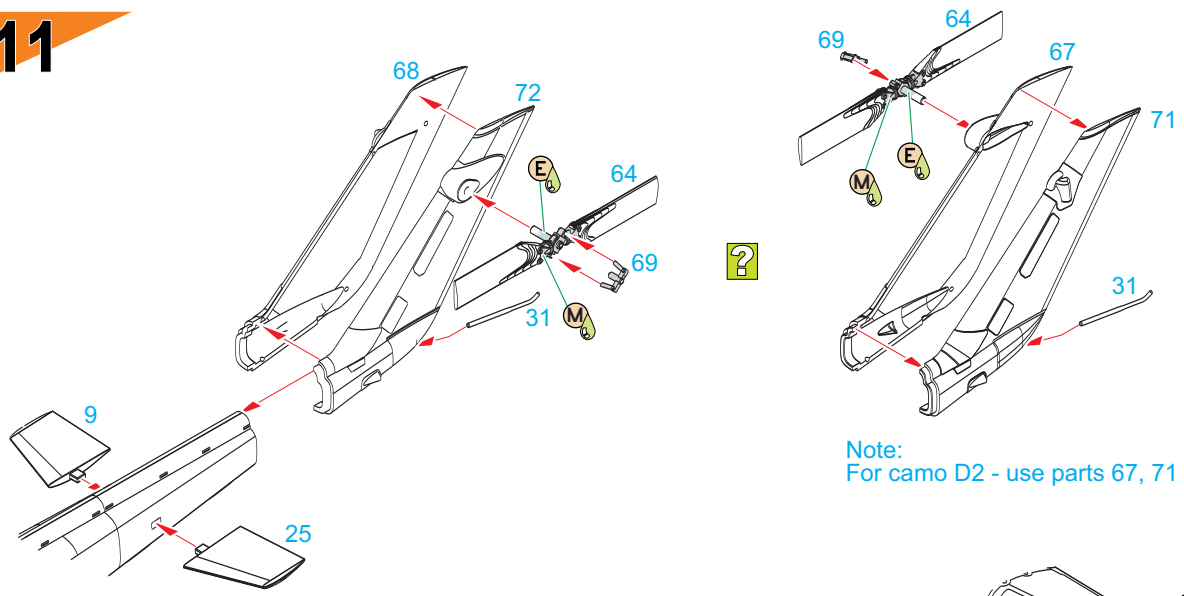

Note:
For camo D2 - use parts 67, 71

12

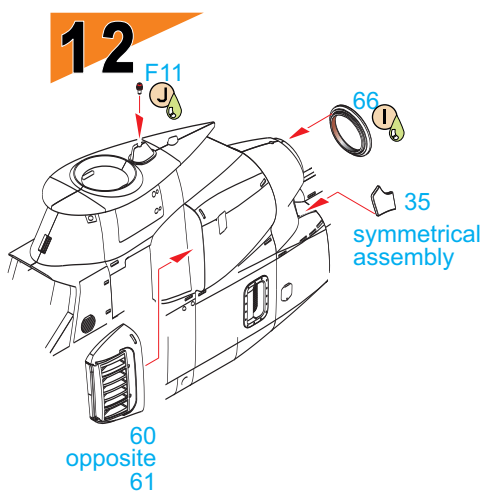

13

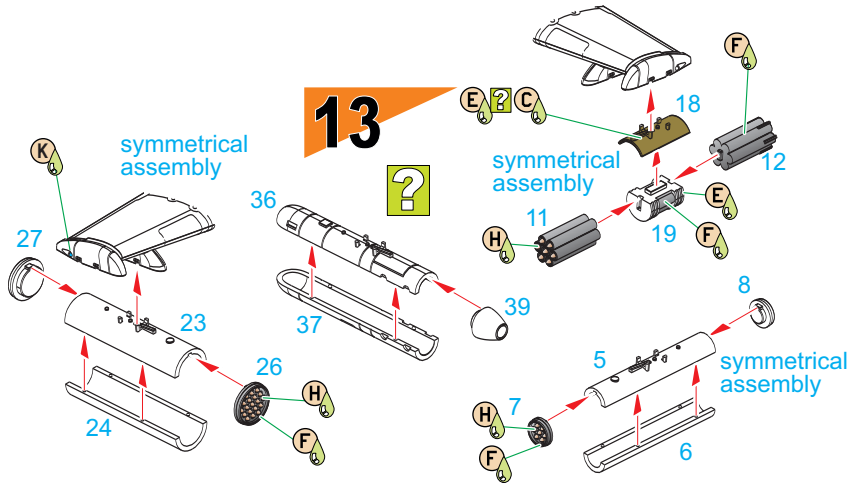

15

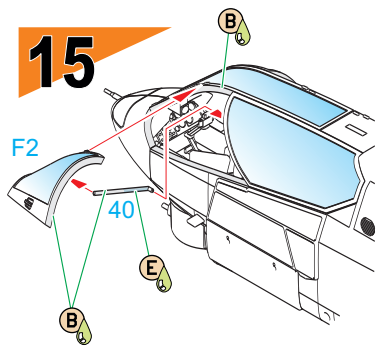

14

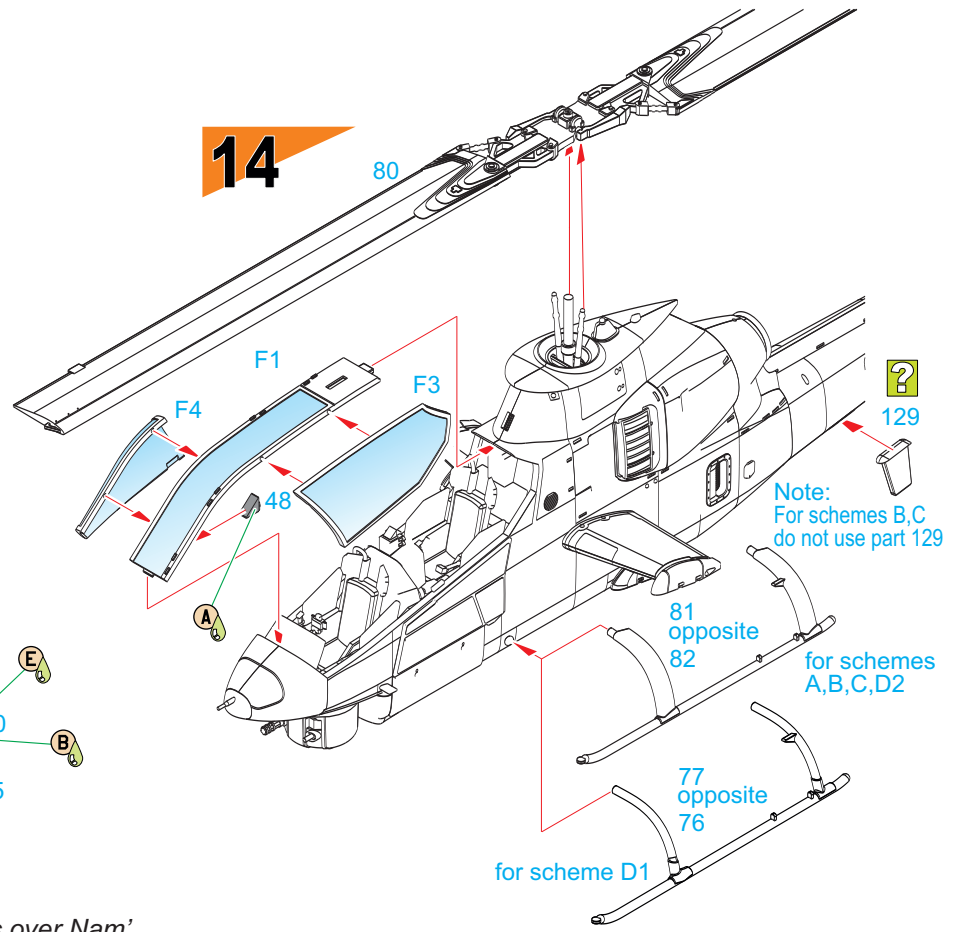

16

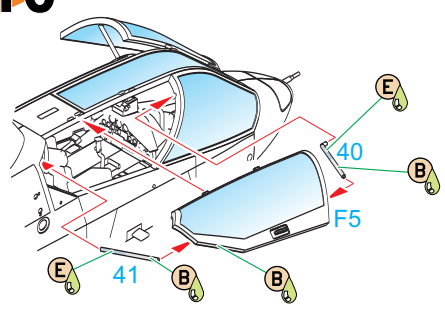

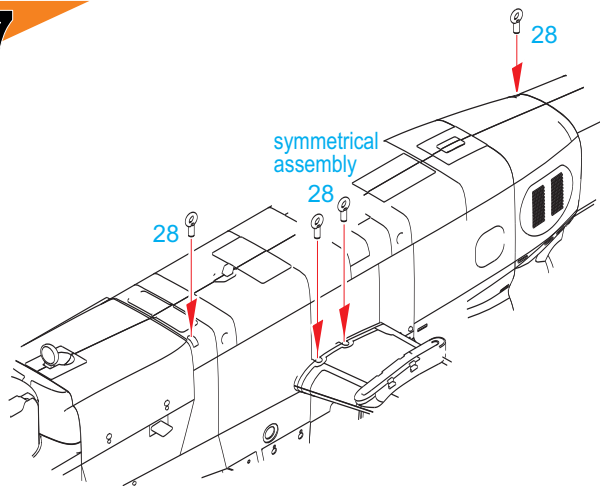
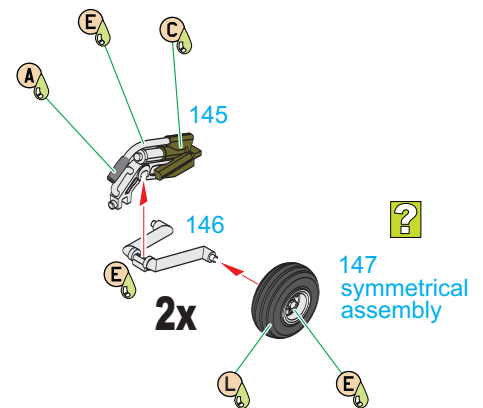
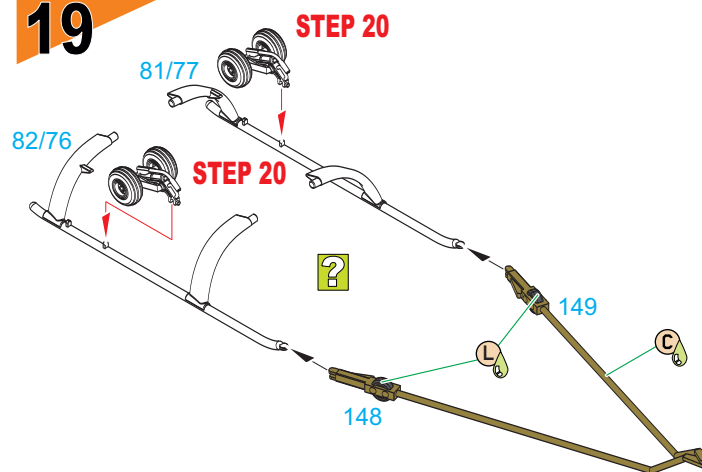
17**18****19**

Pokud chcete vylepšit svůj model AH-1G Cobra, zakupte si zvlášť prodávané barvené lepty MPM Prod. kat. čísla K72028 a resinové sedačky Q72209. Žádejte u svého obchodníka nebo je objednávejte na www.cmkkits.com nebo www.mpmkits.com.

If you want to enhance the level of details of your AH-1G Cobra purchase separately sold MPM Prod. colour photo-etched parts cat. no. K72028 and resin seats Q72209. Ask your local retailer or order them at www.cmkkits.com or www.mpmkits.com.

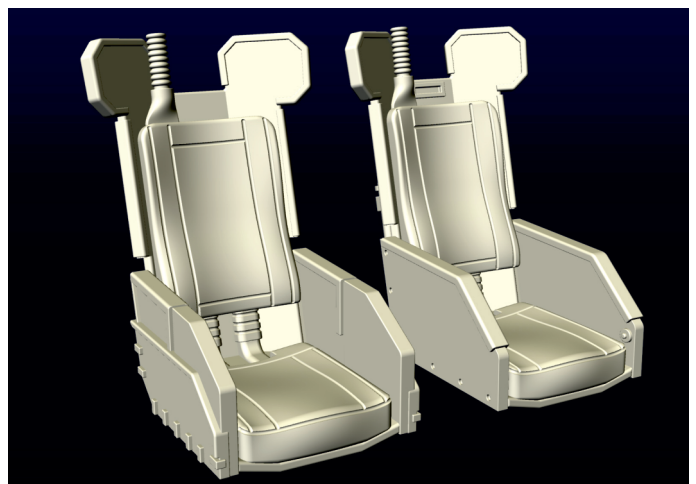
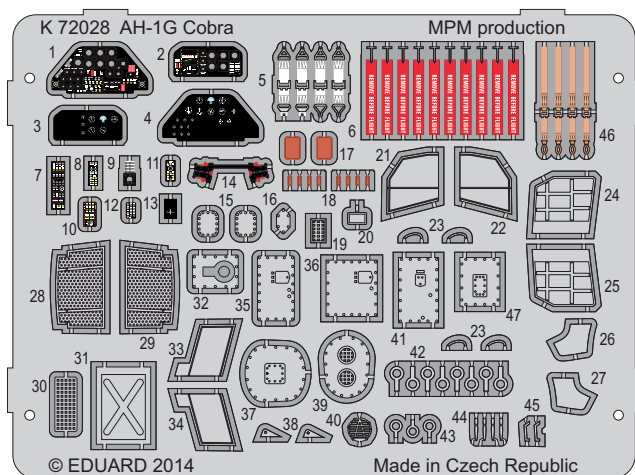

AH-1G sér.č.: 68-15183, pilot Neil McMillan, C/2/20
ARA - C Battery, 2nd Battalion, 20th Regiment,
Aerial Rocket Artillery, Phuoc Vinh, Vietnam, 1971.

AH-1G, s/n 68-15183, flown by Neil McMillan,
C/2/20 ARA - C Battery, 2nd Battalion, 20th
Regiment, Aerial Rocket Artillery, Phuoc Vinh,
Vietnam, 1971.

Scheme A

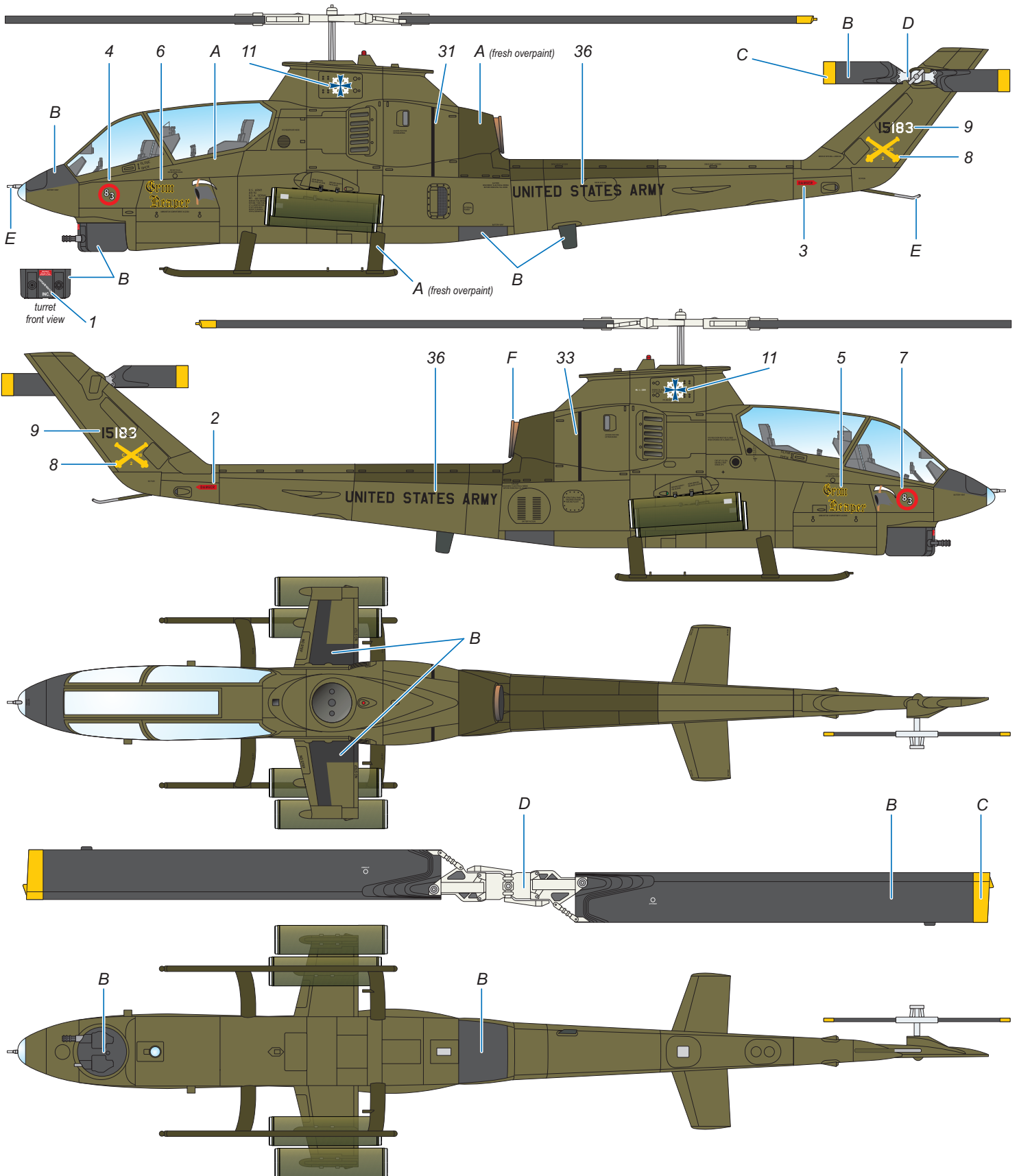

- | | | | | | | |
|--------------------------------------|------------------------------------|----------------------------------|---|-------------------------------------|--|----------------------------------|
| A olivová
Olive
H52/C12 | B černá
Black
H12/C33 | C žlutá
Black
H/C04 | D světle šedá
Light Gray
H21/C69 | E barva kovu
NMF
H/C08 | F opálený kov
Burnt Metal
H76/C61 | G červená
Red
H/C03 |
|--------------------------------------|------------------------------------|----------------------------------|---|-------------------------------------|--|----------------------------------|

AH-1G sér.č.: 68-15049, ve kterém létali 1Lt George Alexander a WO1 Jim Moran, C/2/20 ARA, Bu Dop, Vietnam, červen 1970. Stroje účastníci se invaze do Kambodže měly ocasní nosníky zamalované černou barvou pro skrytí identity.

AH-1G, s/n 68-15049, flown by 1Lt George Alexander and WO1 Jim Moran, C/2/20 ARA, Bu Dop, Vietnam, June 1970. Helicopters participating in the Cambodian invasion had their tailbooms painted in black to obscure the US markings.

Scheme B

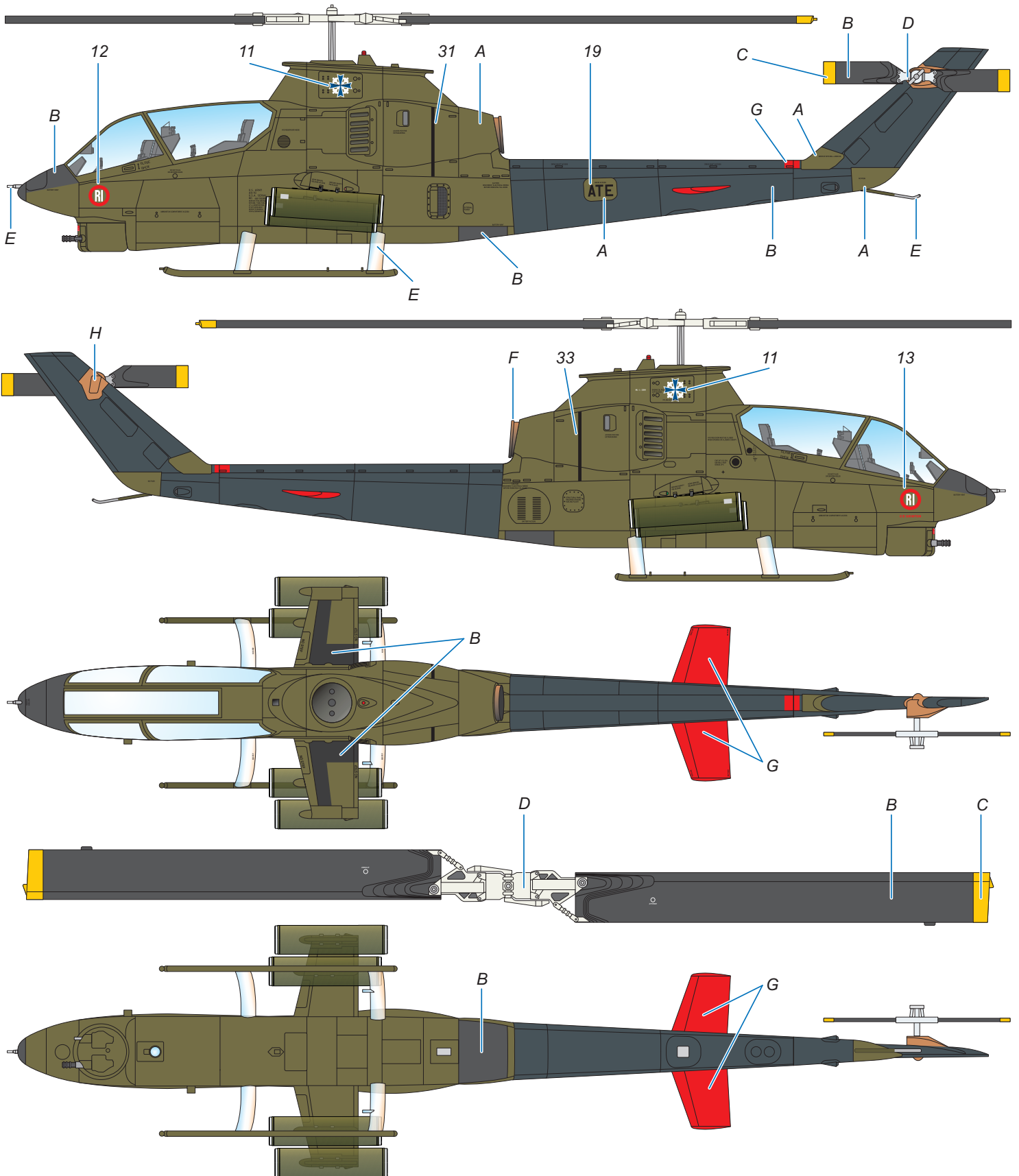

- | | | | | | | | |
|--------------------------------------|------------------------------------|----------------------------------|---|-------------------------------------|--|----------------------------------|------------------------------------|
| A olivová
Olive
H52/C12 | B černá
Black
H12/C33 | C žlutá
Black
H/C04 | D světle šedá
Light Gray
H21/C69 | E barva kovu
NMF
H/C08 | F opálený kov
Burnt Metal
H76/C61 | G červená
Red
H/C03 | H hnědá
Brown
H72/C22 |
|--------------------------------------|------------------------------------|----------------------------------|---|-------------------------------------|--|----------------------------------|------------------------------------|

AH-1G sér.č.: 66-15259, Cobra NETT - New Equipment Training Team, Vung Tau, Vietnam, prosinec 1967. Tento stroj nesl kamufláž v barvách obvyklých pro USAF a také uskutečnil první let tohoto typu nad Jižním Vietnamem, a to dne 4. září 1967.

AH-1G, s/n 66-15259, Cobra NETT - New Equipment Training Team, Vung Tau, Vietnam, December 1967. Wearing an USAF-style camouflage pattern, this machine also happened to complete the first AH-1 flight in South Vietnam on 4 September 1967.

Scheme C

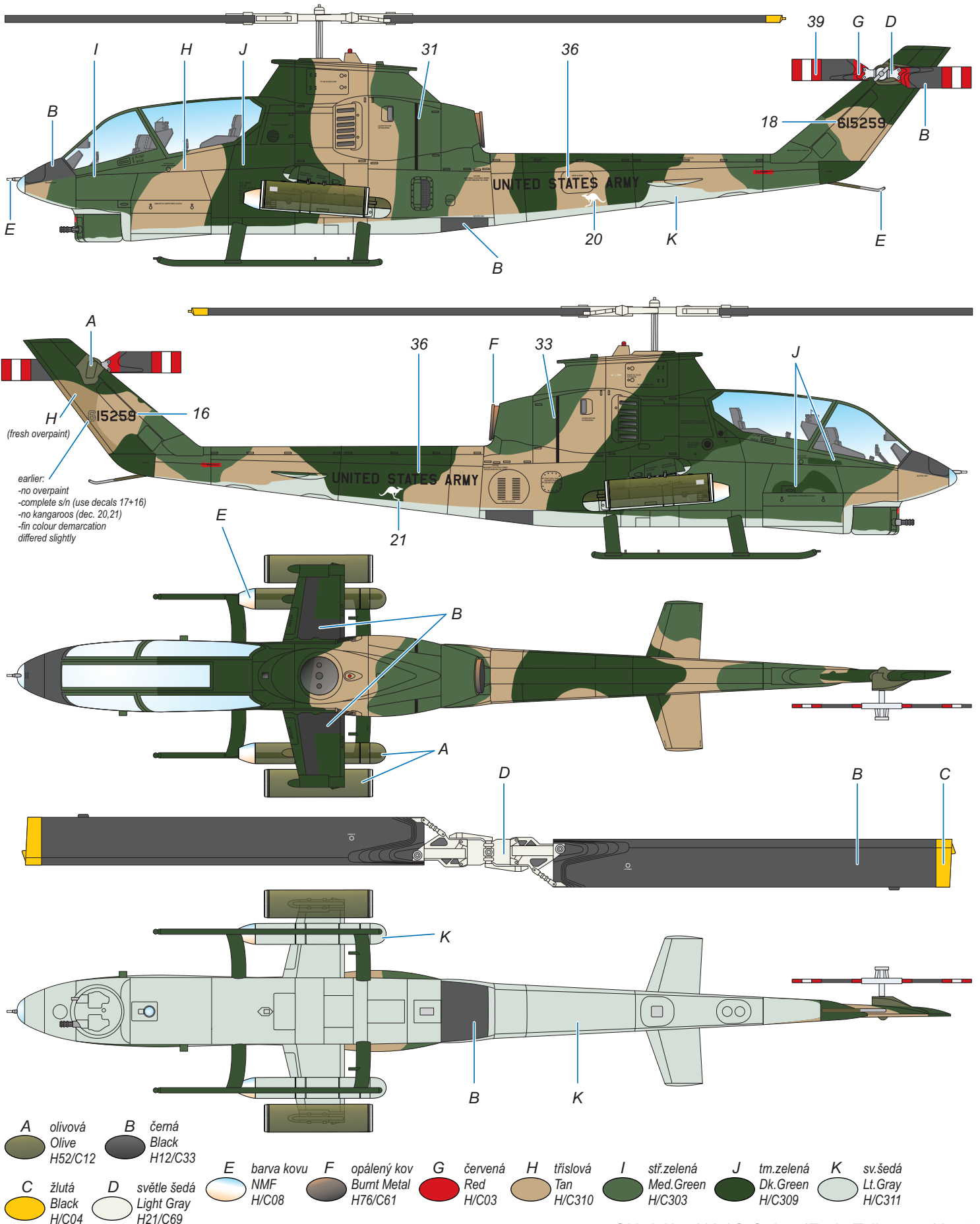

AH-1G sér.č.: 68-15189, D Troop, 3rd Brigade, 4th Cavalry, Chu Chi, Vietnam 1971. V roce 1972 došlo k havárii, při které byl vážně poškozen ocasní nosník a při následné opravě dostala Mildred nový, již s rotorem na pravé straně. Tlama na přídí byla zamalována a na stroji se také objevily čínské znaky, slovo "had" pod pilotní kabinou a sériové číslo na ocasu.

AH-1G, s/n 68-15189, D Troop, 3rd Brigade, 4th Cavalry, Chu Chi, Vietnam 1971. In 1972, Wretched Mildred sustained severe damage to her tail boom which was then replaced with a new one, with the tail rotor on the starboard side. The sharkmouth was repainted, Chinese s/n appeared on the fin and the word snake in Chinese under the pilot canopy.

Scheme D1 - 1971

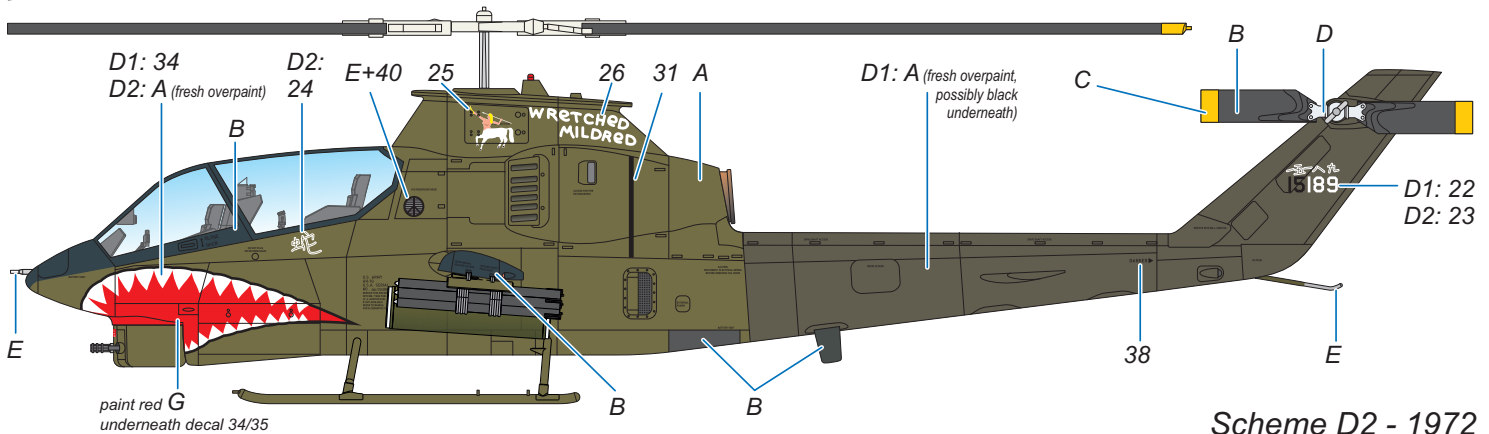

Scheme D2 - 1972

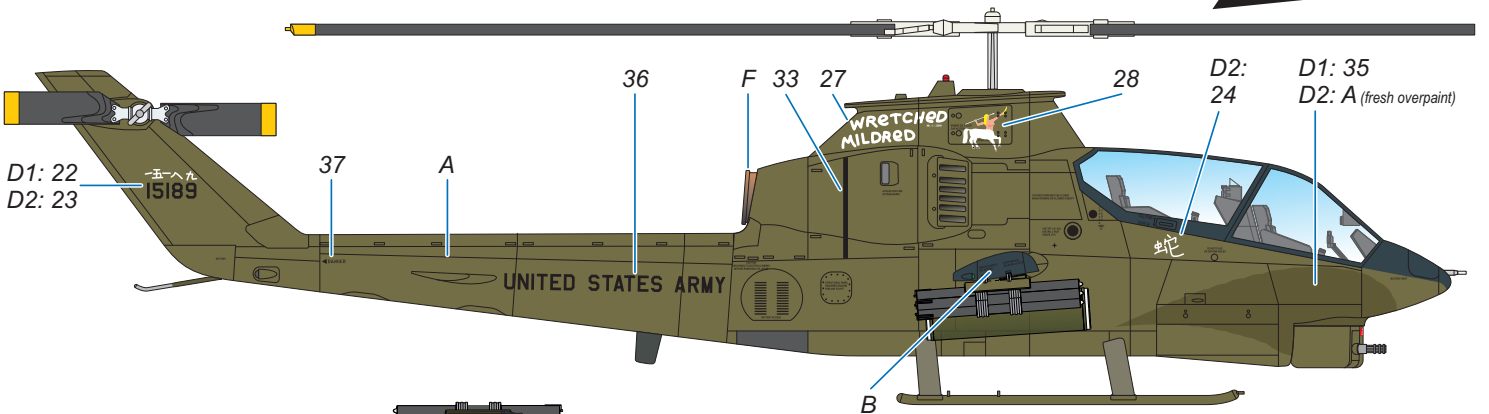

Scheme D1

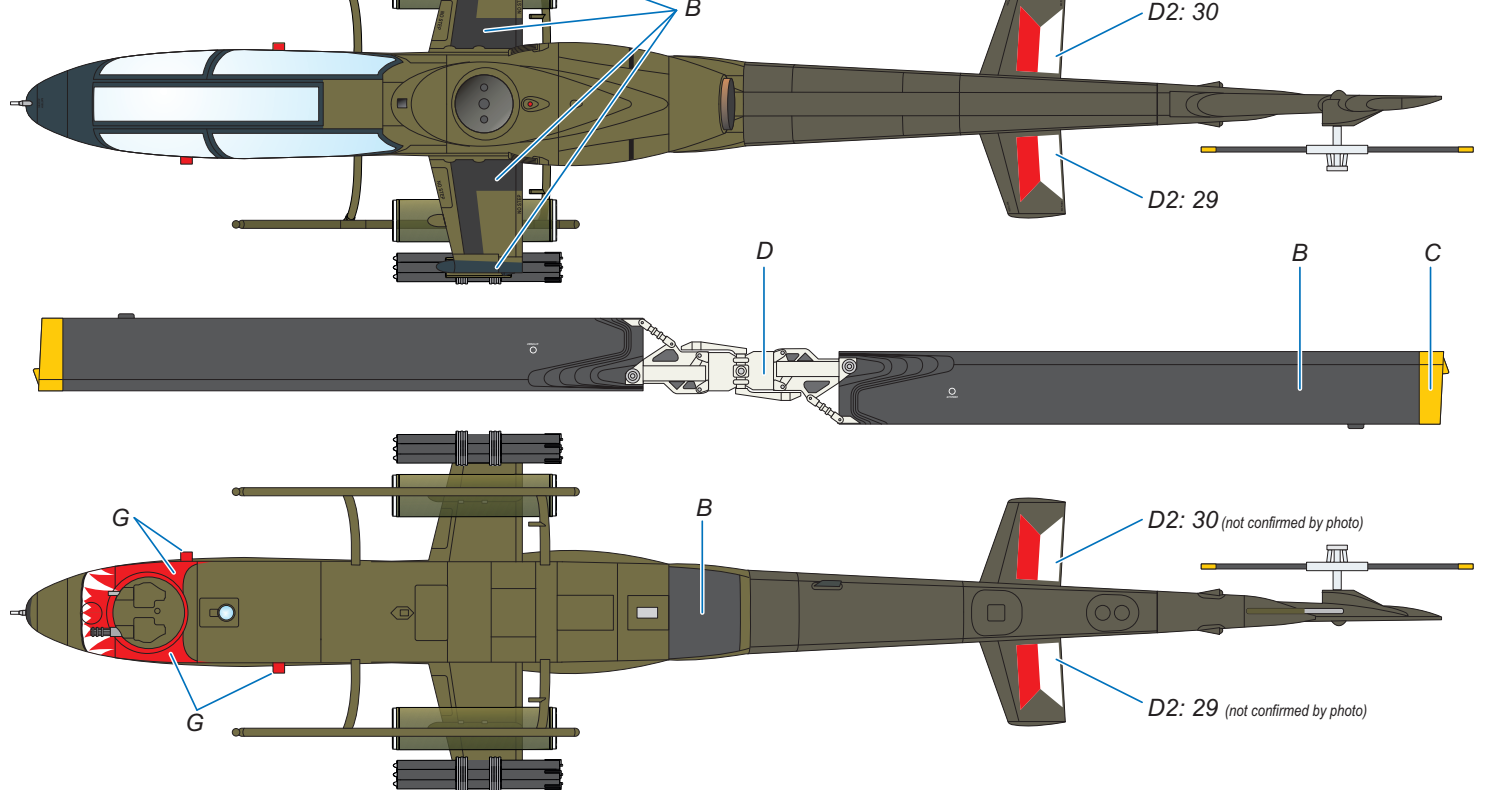

- | | | | | | | |
|--------------------------------------|------------------------------------|----------------------------------|---|-------------------------------------|--|----------------------------------|
| A olivová
Olive
H52/C12 | B černá
Black
H12/C33 | C žlutá
Black
H/C04 | D světle šedá
Light Gray
H21/C69 | E barva kovu
NMF
H/C08 | F opálený kov
Burnt Metal
H76/C61 | G červená
Red
H/C03 |
|--------------------------------------|------------------------------------|----------------------------------|---|-------------------------------------|--|----------------------------------|

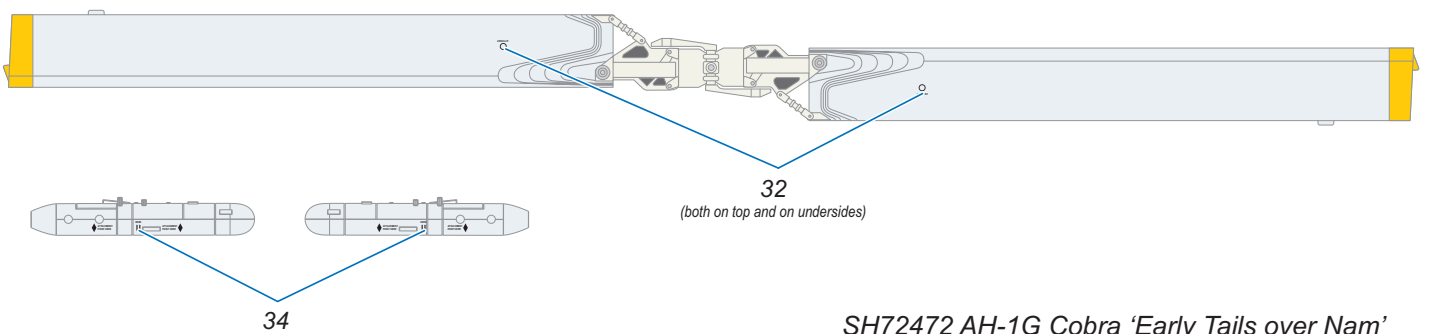
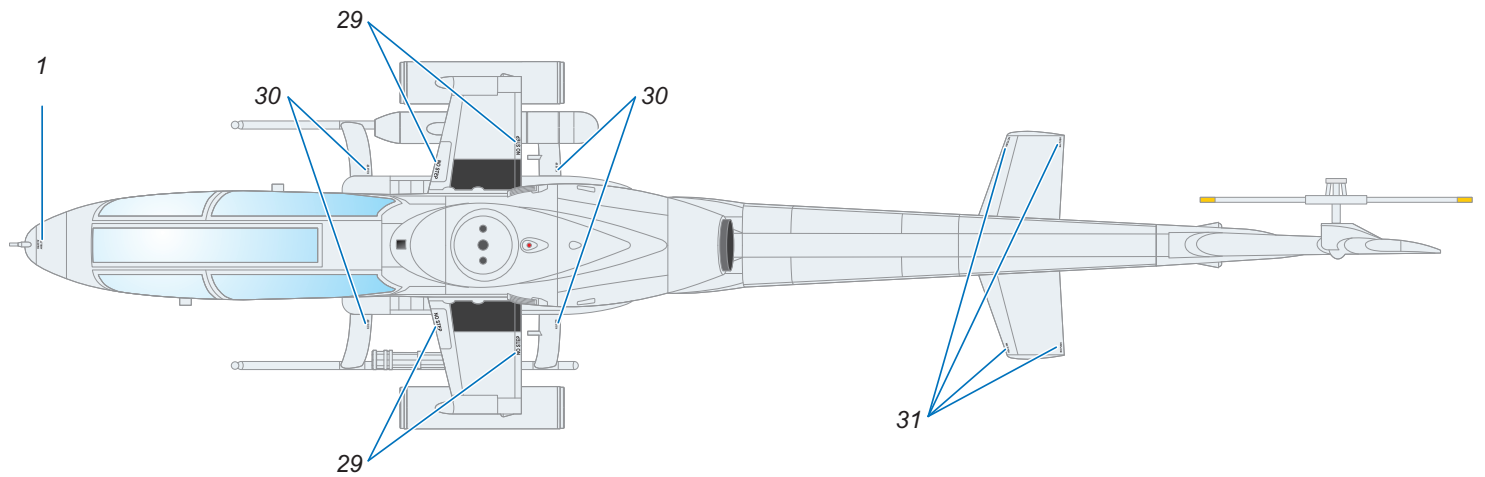
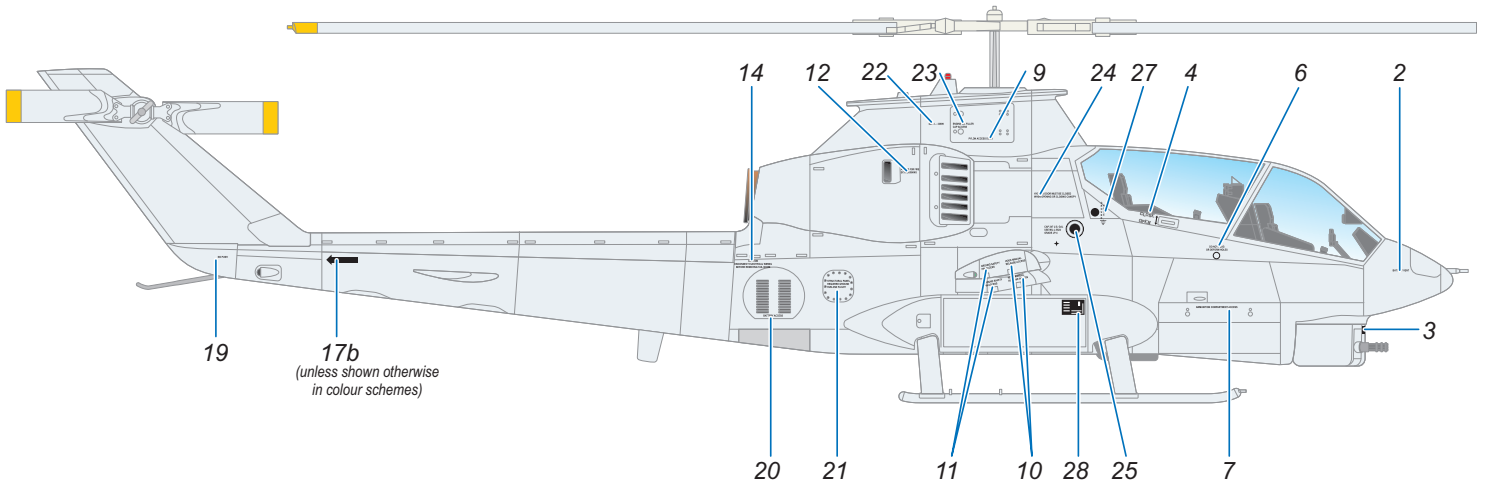
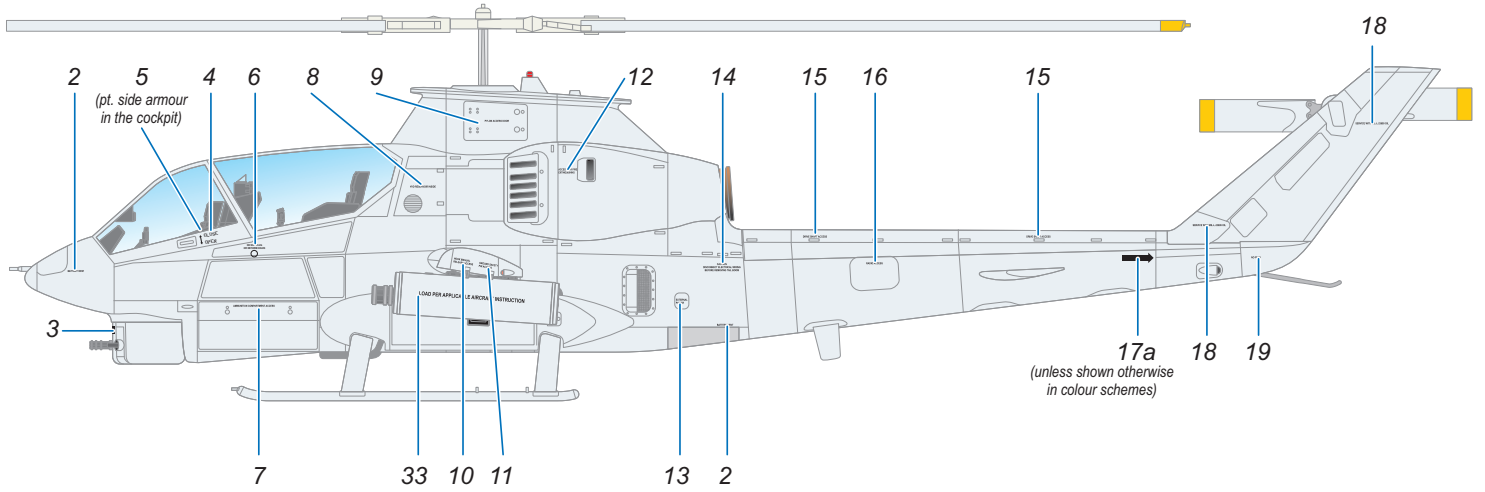

SH72417 1/72 SMB-2 Super Mystère / Sa'ar Duo Pack & Book



Super-Mystère

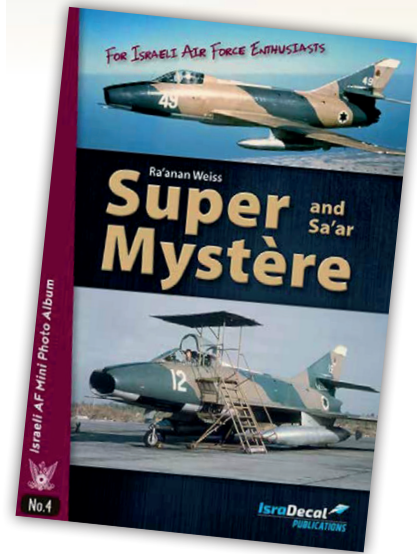

The Razor Saw with Handle (cat. n. H1010) is a great tool for cutting both plastic and resin. CMK also offers a wide variety of coarse/medium/fine saws.

Use this!

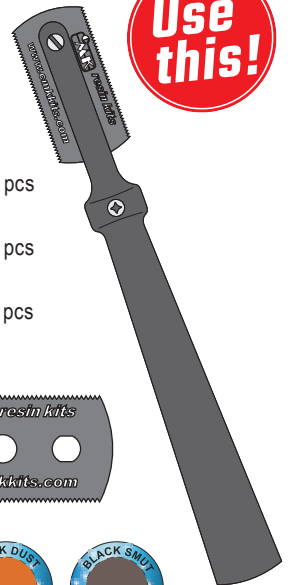

H1000 Ultra smooth and extra smooth saw (2 sides – 70 teeth / 42 teeth) 1 pc

H1001 Ultra smooth saw (both sides – 70 teeth / 70 teeth) 1 pc

H1002 Very smooth saw (both sides – 42 teeth / 42 teeth) 1 pc

H1003 Smooth saw (both sides – 31 teeth / 31 teeth) 1 pc

H1004 Ultra smooth and extra smooth saw (2 sides – 70 teeth / 42 teeth) 5 pcs

H1005 Ultra smooth saw (both sides – 70 teeth / 70 teeth) 5 pcs

H1006 Very smooth saw (both sides – 42 teeth / 42 teeth) 5 pcs

H1007 Smooth saw (both sides – 31 teeth / 31 teeth) 5 pcs

H1010 Razor Saw with Handle



PIGMENTS
for your
kits

Star Dust
weathering pigments



Special
HOBBY

facebook.com/specialhobby

WWW.SPECIALHOBBY.EU | WWW.CMKKITS.COM

CMK
CZECH
MASTER'S KITS

CMK sets, figures and masks for 1/72 AH-1G Cobra

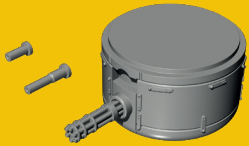

Q72330
AH-1G Early
Emerson Electric
TAT-102 (single
weapon) turret
FOR SPECIAL HOBBY /
REVELL KIT

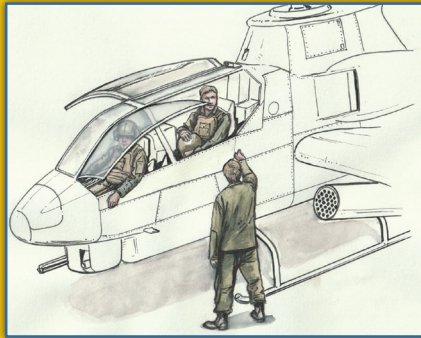

F72349
AH-1 Sitting pilots (2 figures)
and ground crew (1 figure)
FOR SPECIAL HOBBY / REVELL KIT

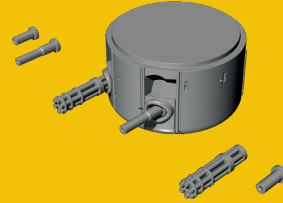

Q72331
AH-1G
Emerson Electric
M28 (dual weapon)
turret
FOR SPECIAL HOBBY /
REVELL KIT



SH72277 1/72
AH-1S Cobra 'IDF against Terrorists'

CMK 1/72 US figures



F72076 Vietnam LRRP US Helicopter crew (3 fig.)

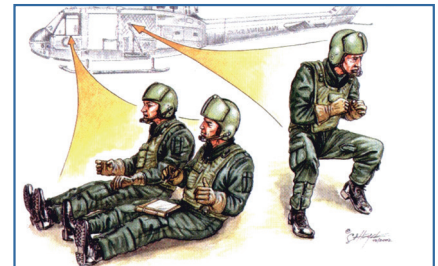

F72080 US helicopter crew, Vietnam War (3 fig.)



F72111 US Airborne Vietnam war (3 fig.)



F72134 US pilots Vietnam war (3 fig.)



Q72338 1/72
AH-1Q/S Hughes M65 Telescopic Sight Unit



SH72283 1/72
AH-1Q/S Cobra 'US Army & Turkey'