

dapol 00/H0 TRACKSIDE MODEL C028: DIESEL CRANE

Made in the UK using recycled plastic



Not suitable for children under 14 years old

Please Note - The tools used to produce this model were made over 50 years ago. Over the period, changes have been made and it may be that reference numbers moulded into the plastic parts do not match the numbers used in these instructions. Therefore we advise you to FOLLOW the exploded diagram and instructions.

ASSEMBLY INSTRUCTIONS: It is recommended that the instructions and exploded view are studied and that the assembly is practiced before cementing together. Certain parts may need to be trimmed and may best be painted before cementing.

- 1: Locate & cement underframe to bottom of platform (1 & 2).
- 2: Locate & cement underframe sides, immediately below edges of platform, ensure that the ends are in line with the platform.
- 3: The desired coupling must now be selected. Note that in addition to scale coupling hooks for non-working models, a working 'Buckeye' type of coupling is provided.
- 4: If working couplings have been selected, cement the coupling bushes over the studs beneath each platform end (5 & 6).
- 5: Cement the buffer plates (7 & 8) into position. Note that if working couplings are used then the recessed slot in the rear of each plate should first be cut right through.
- 6: Cement buffers (9 - 12) into the plates.
- 7: For working couplings, the end of the coupling should be pushed through the slot in the buffer plate and then cemented from the rear. **ENSURE NO CEMENT TOUCHES THE COUPLING.**

PLATFORM ASSEMBLY

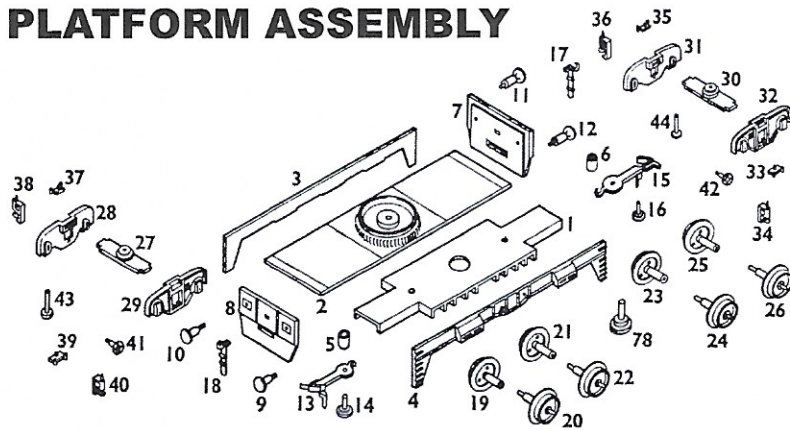

- 8: Repeat the above for the second coupling and when totally dry, use a small elastic band to connect the small hooks on each coupling, ensuring that the band passes on either side of the bogie pivot bushes (15 & 16).
- 9: If scale couplings have been selected, cement the locating lugs into the central slot of the buffer plates (17 & 18).
- 10: Cement axle pins of wheels and apply to axle holes of other wheels (19 - 26). Ensure that wheels run true.
- 11: Cement bogie beam, boss uppermost into one plain bogie side. Locate the wheel into the axles box slots and cement in place second bogie side (with hand wheel locating hole), at the same time engaging the wheels (27 - 29).
- 12: Repeat above procedure for the second bogie (30 - 32).
- 13: Cement top jack-plate into recessed step on top of bogie side and cement jack into place below plate, pushing jack into central cut-out (33 & 34).
- 14: Cement remaining jacks into place (35 - 40).
- 15: Cement brake hand wheels in bogie side holes (41 & 42).
- 16: Apply cement to the ends of the straight pivot pins (43 & 44) and press into place through the underside of bogie beams and into bushes. **ENSURE NO CEMENT TOUCHES THE BOGIES.**

BODY ASSEMBLY

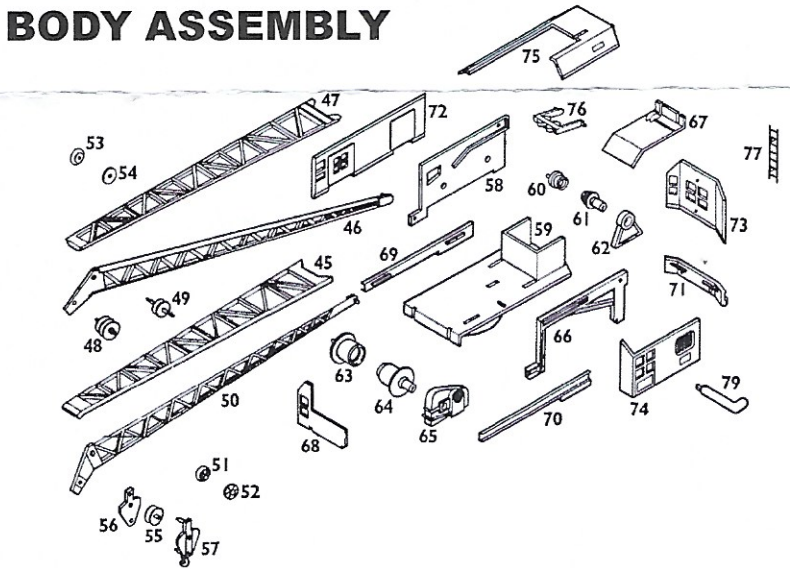

- 17: Cement bottom of jib, with angled end, to right side of jib and apply top of jib to side (45 - 47).
- 18: Press end (double) pulley into locating hole in end of jib and long axled pulley into hole at angle of jib (48 & 49).
- 19: Cement left-hand side of jib into place, at the same time locating pulleys.
- 20: Cement together inner and outer halves of derrick pulleys and cement assembled pulleys onto projecting ends of long axled pulley (51 - 54). **ENSURE NO CEMENT TOUCHES THE JIB.** Set aside to fully dry.
- 21: Press hook pulleys to plain hook side, then cement second side of hook into place (55 - 57) and set aside to fully dry.
- 22: Cement right-hand frame to cab base, locating in right-hand cut out base front and in rear slot of base (58 & 59).
- 23: Cement one half of derrick cable drum into the second half; when dry locate small pin into right-hand frame rear hole, then press support bracket over the projecting spindle of drum and cement lug of bracket into central base slot (60 - 62).
- 24: Similarly, assemble larger hoist drum, locate in forward hole of frame, press hoist gearbox cover over projecting spindle and cement gearbox tab into cab base slot (63 - 65).
- 25: Cement left-hand frame into position, engaging in cut out in front of cab base and in rear slot (66).
- 26: The rigging should now be started. For best results use fine cotton or nylon thread, cut into two lengths; one +/- 24" and one +/- 36" long. Tie the shorter length around the front hoist drum and secure to drum with a drop of cement. Tie and cement the longer to the rear derrick drum.
- 27: Cement central roof section on ribs inside frames (67). Lead rear cable out over half pulley in roof.

RIGGING

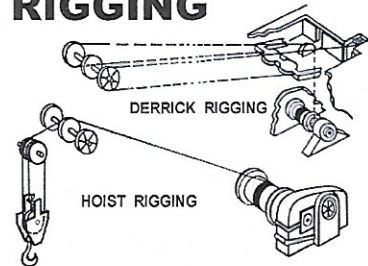

- 28: Cement front cab into place (68) locating over projecting ends of frames; lead front cable out over front plate.
- 29: Locate right side girder in place on right-hand side of cab base, the top level with top of cab base (69).
- 30: Similarly, cement in place left side and rear girders (70 & 71).
- 31: Cement right-hand cab in place on top of and overlapping girder (72).
- 32: Cement cab rear on rear girder and to right cab side, then cement left cab side to rear and to left girder (73 & 74).
- 33: If crane is to be made operative then it is recommended that any ballast weight is placed within the rear box.
- 34: Cement roof into position after first ensuring that the rear cable is in place within the slot over the integral pulley (75).
- 35: Spring the bar with the rear derrick into place, the pins on this bar locate within the side frame holes on either side of the roof section. **DO NOT CEMENT.**
- 36: Cement cab ladder into position (77).

- 37: Mount the cab onto the assembled chassis after first placing a drop of cement within the pivot bush on the cab floor. Press the central pivot pin through the underframe into the cab location. **ENSURE NO CEMENT TOUCHES THE UNDERFRAME.**
- 38: The jib can now be sprung into its location in front of the cab frames and the rigging completed as shown in the drawing. Note that after passing around the pulleys, the hoist cable is tied to the top bar of the hook and the derrick cable to the small rod moulded in the roof.
- 39: To operate the crane, the winding key (79) is inserted into the square holes in the cable drums and turned. To reach the derrick drum spindle the key is pushed through the left-hand window.

WARRANTY: Parts can get bent during transit or by prolonged storage. However misshapen parts can be straightened by placing them in hot water to soften the plastic and then carefully manipulating them back into shape by finger pressure. Please be careful that the water does not cause harm to skin or fingers. In the event of parts being broken or missing, then you **MUST** return to the place of purchase (the seller). The seller will replace your kit and return the original kit to Dapol under their agreed contractual terms. Do **NOT** return to Dapol. Finally please note that Dapol does not keep individual parts for any kit.