

11

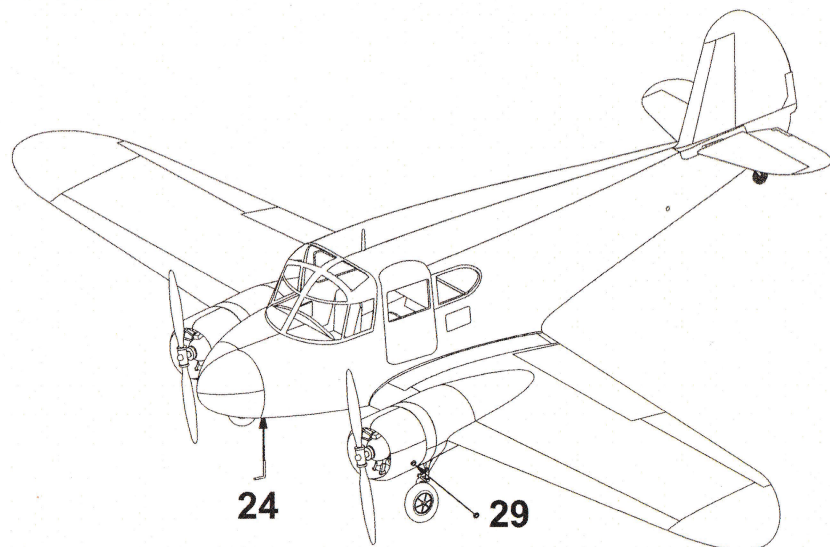

12

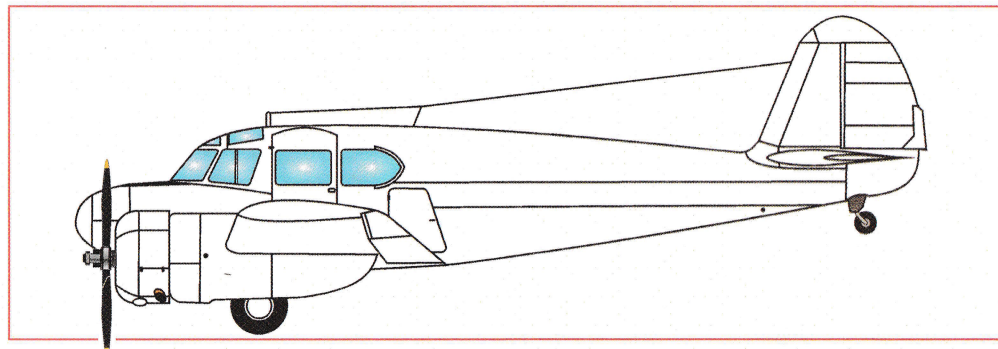
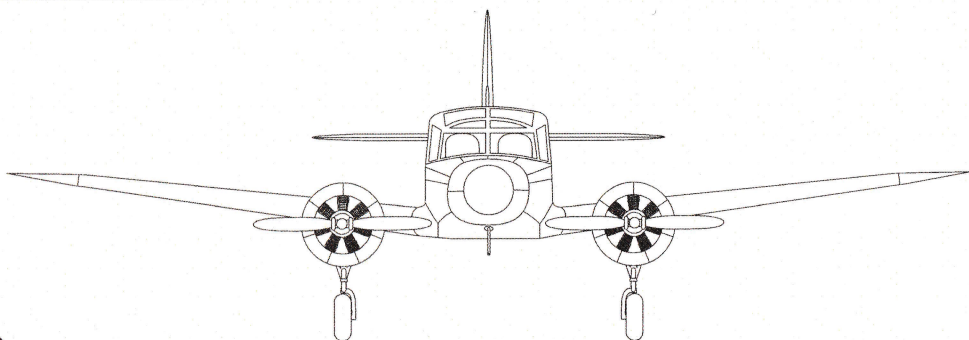
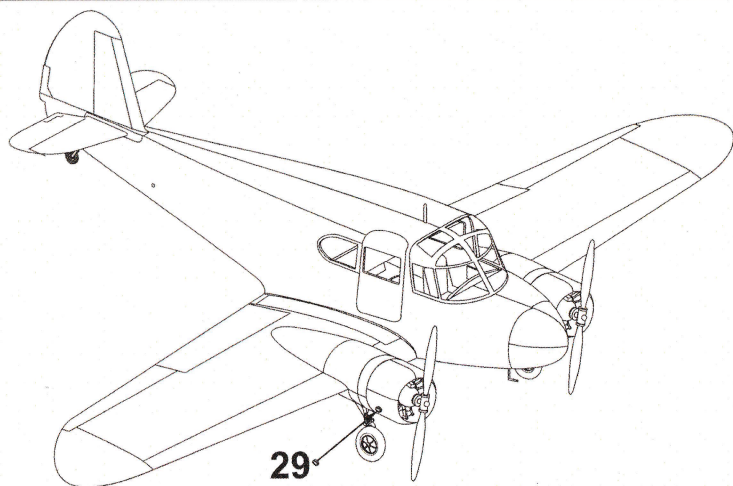

KOVOZÁVODY

PROSTĚJOV

CESSNA BOBCAT/CRANE

Cessna T-50 Bobcat byl americký víceúčelový dvoumotorový pětimístný dolnoplošník smíšené konstrukce se zatahovacím podvozkiem ostruhového typu.

Zahájením II. světové války přišly pro typ T-50 vojenské zakázky. Velká Británie vyhlásila program Commonwealth Joint Air Training Plan, jehož úkolem byl výcvik osádek pro Royal Air Force v zemích Britského společenství národů nezasažených bezprostředně válečným konfliktem. Pro letecké školy RCAF proto Británie objednala 640 letounů označených Cessna Crane Mk.I, po nichž následovala zakázka na 190 exemplářů Crane Mk.II se zdokonaleným vybavením. Instalovány byly dvojice pohonných jednotek Jacobs R-755-9. Dodávky byly zahájeny v roce 1941.

Už v prvních dnech války zabavilo americké armádní letectvo 17 z letuschopných civilních T-50 a zařadilo je do výzbroje jako C-78A (později UC-78A). V roce 1942 přišla zakázka na 3356 nových letounů UC-78A až UC-78C, které se rozšířily ve všech bojových oblastech působení amerického letectva.

TECHNICKÁ DATA/TECHNICAL DATA:

| | |
|-----------------------------------|--------------------------------------|
| Posádka/Crew: | 4 |
| Motor/Powerplant: | 2xJacobs L-4MB nebo 2xJacobs R-755-9 |
| Výkon/Power: | 180 kW |
| Rozpětí/Wingspan: | 12,78 m |
| Délka/Length: | 10,00 m |
| Výška/Height: | 3,03 m |
| Nosná plocha/Wing area: | 27,50 m ² |
| Hmotnost prázdná/Empty weight: | 1836 kg |
| Hmotnost vzletová/Takeoff weight: | 2586 kg |
| Dostup/Climb: | 6000 m |
| Dolet/Radius: | 1200 km |
| Max. rychlost/Max. speed: | 314 km/h |

POUŽITÉ PODKLADY/ REFERENCES USED:

Letečtví a kosmonautika
Československá letadla 2, Václav Němeček
osobní archiv/personal files

The AT-17 was a military version of the commercial Cessna T-50 light transport. The Cessna Airplane Company first produced the wood and tubular steel, fabric-covered T-50 in 1939 for the civilian market, as a lightweight and low-cost twin for personal use where larger aircraft such as the Beech 18 would be too expensive. A low-wing cantilever monoplane, it featured retractable main landing gear and wing trailing edge flaps, both electrically actuated. The wing structure was built up of laminated spruce spar beams with spruce and plywood ribs. The fixed tailwheel is not steerable and full-swivelling. The prototype T-50 made its maiden flight on 26 March 1939.

In 1940, the United States Army Air Corps ordered them under the designation AT-8 as twin-engined advanced trainers.

822 Bobcats had been produced for the Royal Canadian Air Force as Crane Is, many of which were used in the BCATP. Surviving military aircraft were declared obsolete in 1949

REALIZAČNÍ TÝM / REALISATION TEAM:

| | |
|--------------------------|--------------------|
| Předlohový model: | Petr Muzikant |
| Master model: | Jiří Válek |
| Formy a výroba: | Milan Pala |
| Moulds and production: | Carlos Alonso |
| Titulní kresba: | Jarda Š |
| Boxart: | |
| Návod: | Gustav Hybner |
| Instructions: | |
| Grafika a návrh obtisků: | KP |
| Graphic design, decals: | |
| Tisk obtisků: | Slavomír Goldemund |
| Decal printer: | Miroslav Balous |
| Konzultanti: | Václav Šorel |
| Consultants: | Jaroslav Velc |
| | Michal Ovčáčík |
| | Petr Šafra |
| | Pavel Šípka |

VOLITELNÉ
OPTIONALVYVRTAT
DRILL HOLETMEL
PUTTYODSTRANIT
REMOVE

Používejte pouze vhodné nářadí, lepidlo a barvy. Během práce nejezte a nepijte.
POZOR - obsahuje malé součásti, které mohou mít ostré hrany. Není vhodné pro děti.

Use proper tools, glue and paints. Do not eat and drink during the work.
WARNING - contains small parts with possible sharp edges. Not suitable for children.

Plastikové díly - Plastic parts

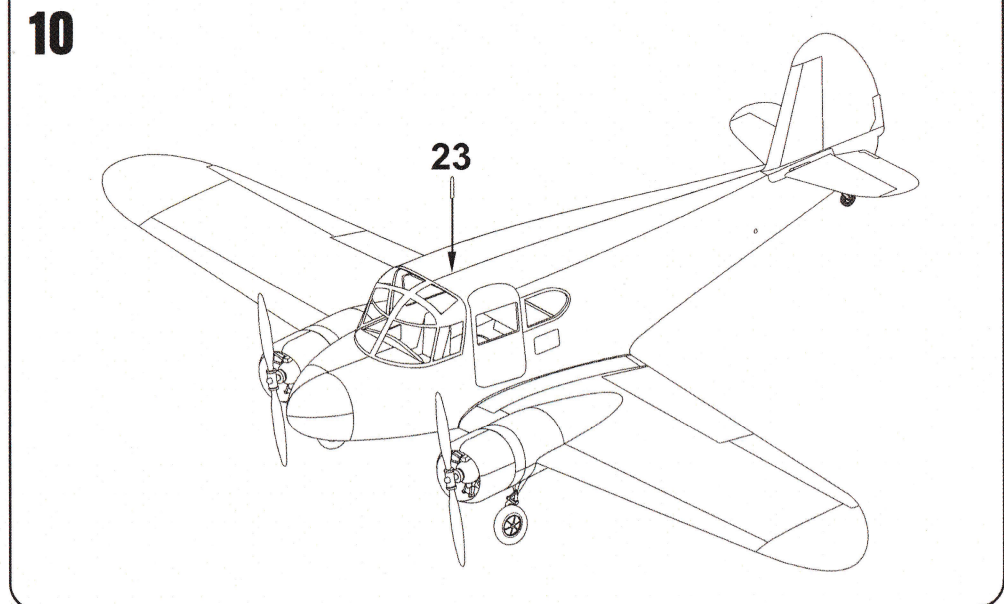
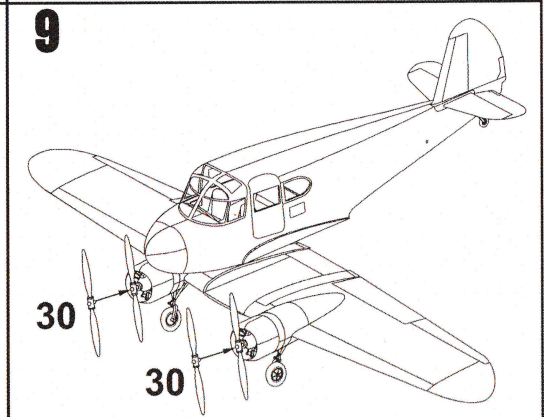
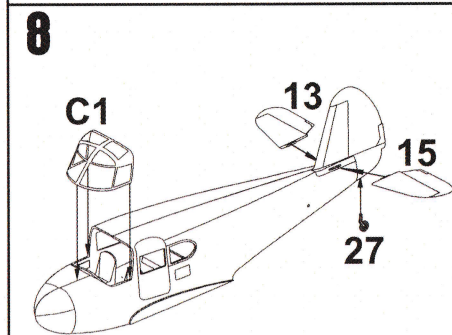
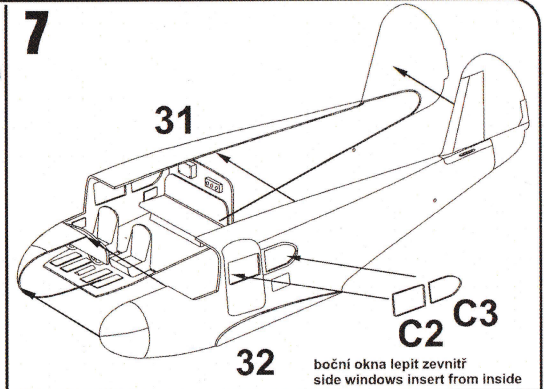
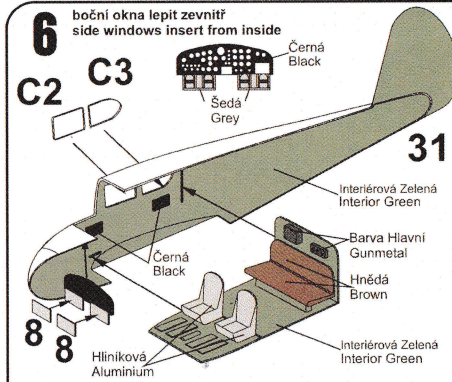
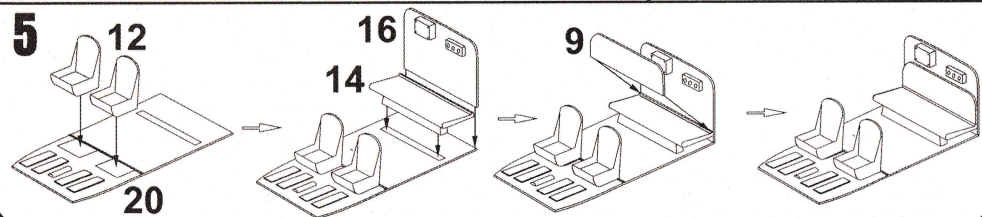
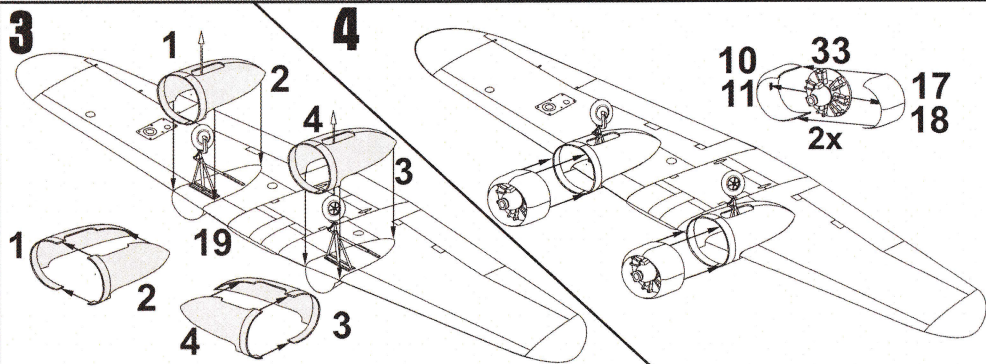
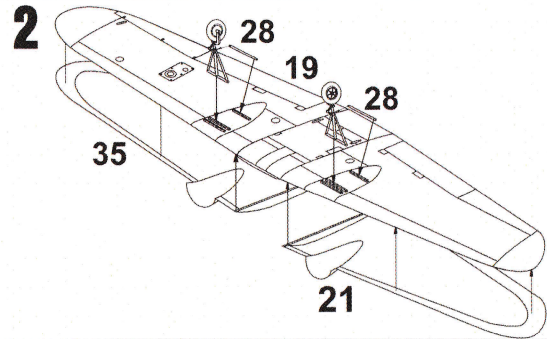
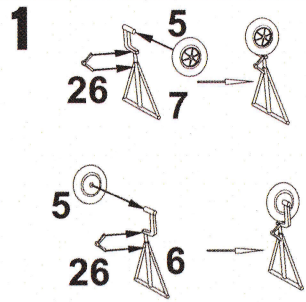
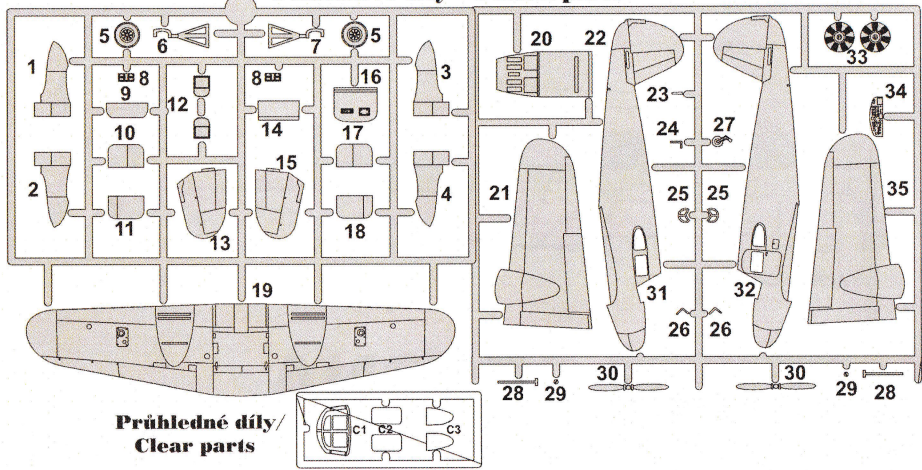

1

Cessna T-50 Bobcat, No.3999, OK-ZCB,
letoun pobočky firmy Bata, Svit, Československo, 1949.
Cessna T-50 Bobcat, No.3999, OK-ZCB,
Bata company, Svit, Czechoslovakia, 1949.



Zbarvení & Označení
Colours & Marking

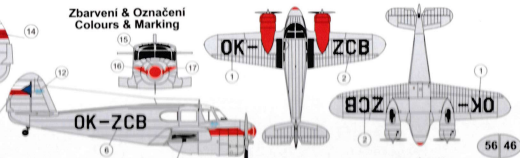

2

Cessna T-50 Bobcat, PH-NCL, Aero-Holland, Frits Diepen, Aerotaxi,
Netherland.
Cessna T-50 Bobcat, PH-NCL, Aero-Holland, Frits Diepen, Aerotaxi,
Netherland.

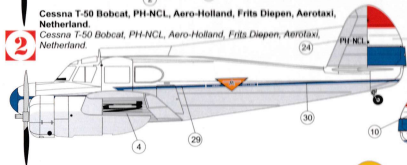

3

Cessna T-50 Bobcat, SP-GLC, letecký institut Varšava,
Polsko, 1962.
Cessna T-50 Bobcat, SP-GLC, Aviation Institute Warsaw,
Poland, 1962.

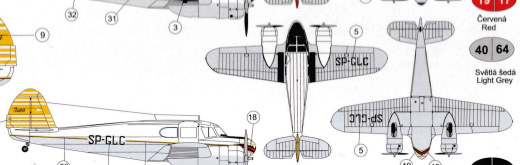
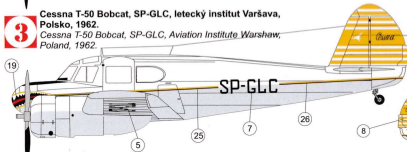

4

Cessna T-50 Bobcat, N67832, name „Songbird“, radio and television's
flying Rancher, Sky King, USA
Cessna T-50 Bobcat, N67832, name „Songbird“, radio and television's
flying Rancher, Sky King, USA

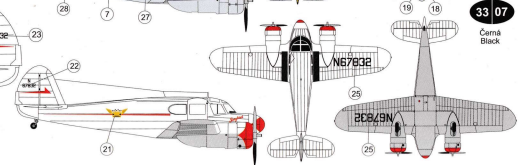
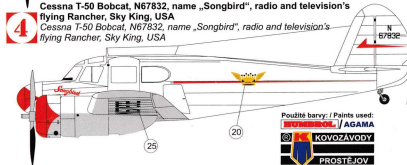

Použitá barvy: / Paints used:

AGAMA

KOVOZÁVODY

PROSTĚJOV

56 46

Hlínik
Aluminium

22 14

Bílá
White

19 17

Červená
Red

40 64

Světlá šedá
Light Grey

33 07

Černá
Black