

Clear Prop!

ADVANCED



DH.88 COMET

1:72
model # CP72019



scale model kit

SPAN 186.26mm

LENGTH: 122.8 mm





NUMBER OF PARTS: 105 pcs

-  stages of assembly
-  variants of assembly
- A1** part number
-  separate details
-  apply decals
-  apply the adhesive mask
-  bend
-  optional
-  glue by super glue
-  do not glue
-  make a hole
-  detach with knife
-  paint
-  repeat the operation N times

Role	Racing aircraft
Manufacturer	de Havilland
Designer	A. E. Hagg
First flight	8 September 1934
Status	One airworthy; one in restoration
Number built	5

The de Havilland DH.88 Comet is a British two-seat, twin-engined aircraft built by the de Havilland Aircraft Company. It was developed specifically to participate in the 1934 England-Australia MacRobertson Air Race from the United Kingdom to Australia. Development of the Comet was seen as both a prestige project and an entry into the use of modern techniques. It was designed around the specific requirements of the race. Despite being made of wood, it was the first British aircraft to incorporate in one airframe all the elements of the modern fast monoplanes. Three Comets were produced for the race, all for private owners at the discounted price of £5,000 per aircraft. The aircraft underwent a rapid development cycle, performing its maiden flight only six weeks prior to the race. Comet G-ACSS Grosvenor House emerged as the winner. Another two Comets were built after the race. The Comet established many aviation records, both during the race and in its aftermath, as well as participating in further races. Several examples were bought and evaluated by national governments, typically as mail planes. Two Comets, G-ACSS and G-ACSP, survived into preservation, while a number of full-scale replicas have also been constructed. The de Havilland Comets set many record times for long-distance flights during the 1930s, both during races and on special record-breaking flights. Some flights set multiple point-to-point records.

REQUIRED PAINTS

- | | | | | | | | |
|--|--|--|--|---|---|---|--|
| A 
MR. COLOR 90
A.MIG-8215
SHINE SILVER | B 
MR. COLOR 302
A.MIG-0238
GREEN | C 
MR. COLOR 8
A.MIG-0195
SILVER | D 
MR. COLOR 1
A.MIG-0047
WHITE | E 
MR. COLOR 33
A.MIG-0046
BLACK | F 
MR. COLOR 44
A.MIG-0013
TAN | G 
MR. COLOR 137
A.MIG-0033
TIRE BLACK | H 
MR. COLOR 13
A.MIG-0239
NEUTRAL GREY |
| I 
MR. COLOR 27
A.MIG-0220
INTERIOR GREEN | J 
MR. COLOR 28
A.MIG-0191
STEEL | K 
MR. COLOR 61
A.MIG-0187
BURNT IRON | L 
MR. COLOR 3
A.MIG-0049
RED | 
AMMO
by MIG Jimenez | | | |

THIS MODEL IS PRODUCED FOR EXPERIENCED MODELERS OVER 14 YEARS

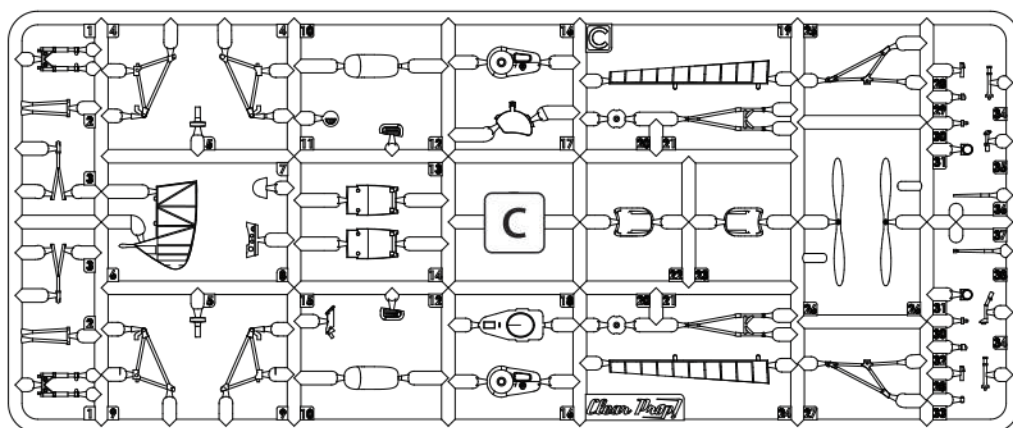
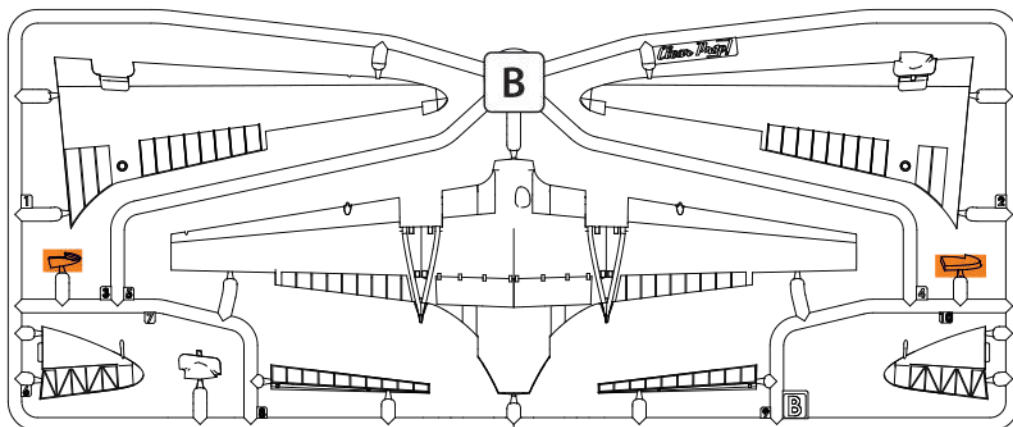
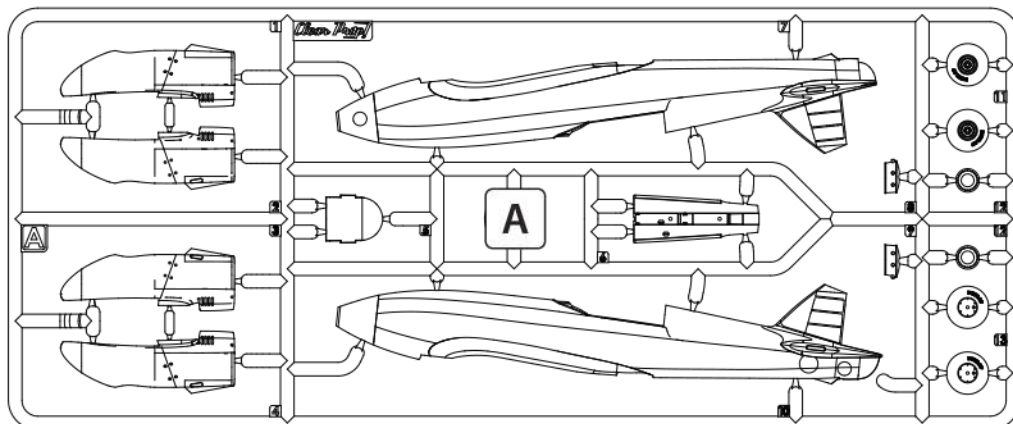

DECAL SHEET

PHOTOETCHED PARTS

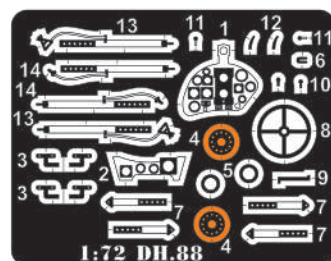
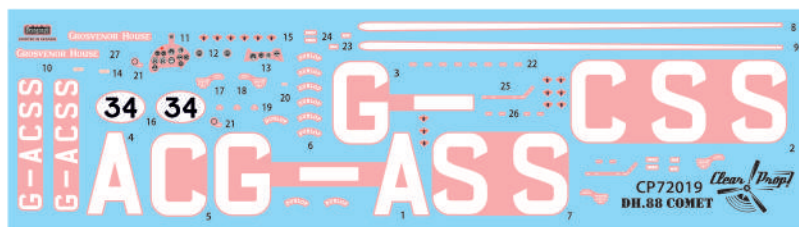
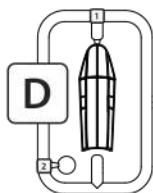

Parts not for use

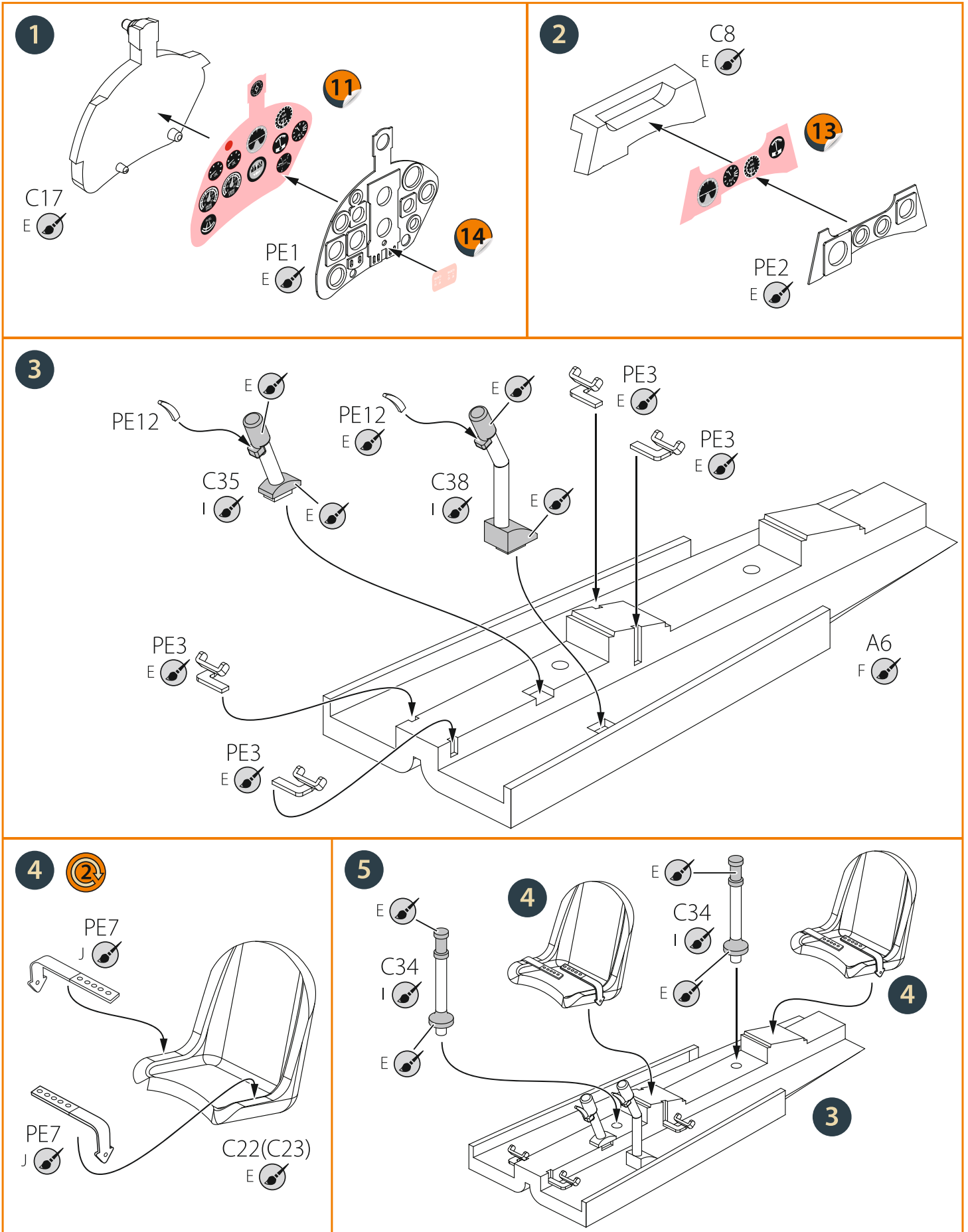

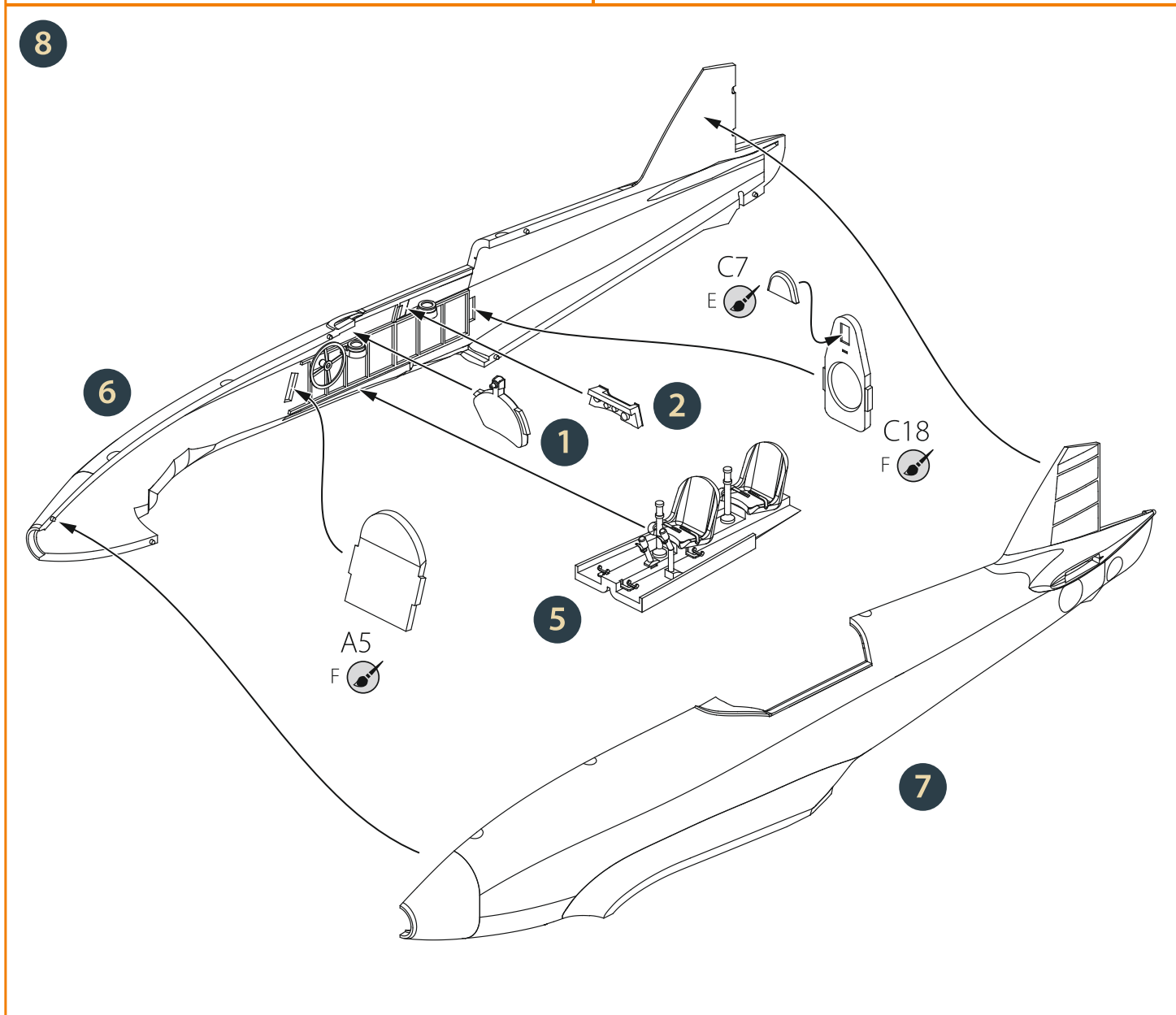
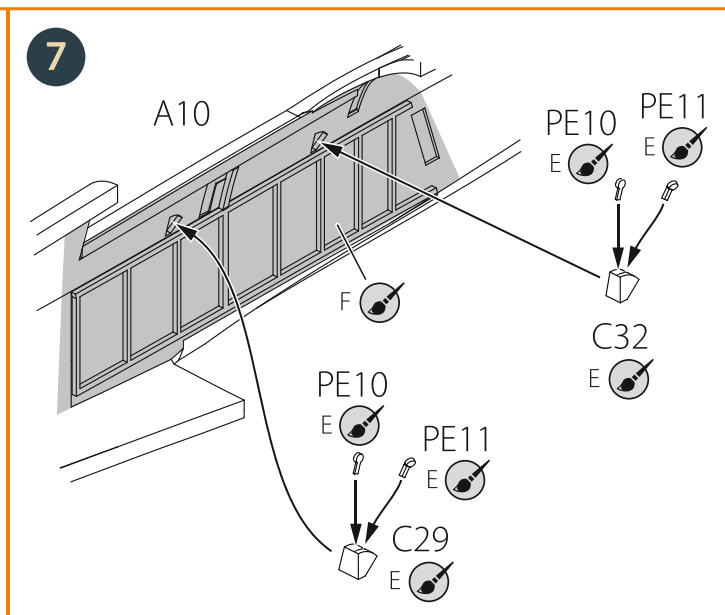
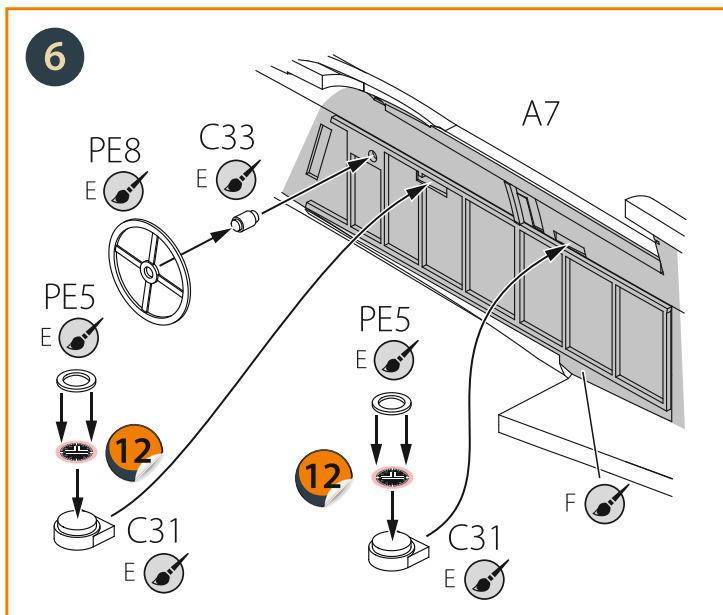

9

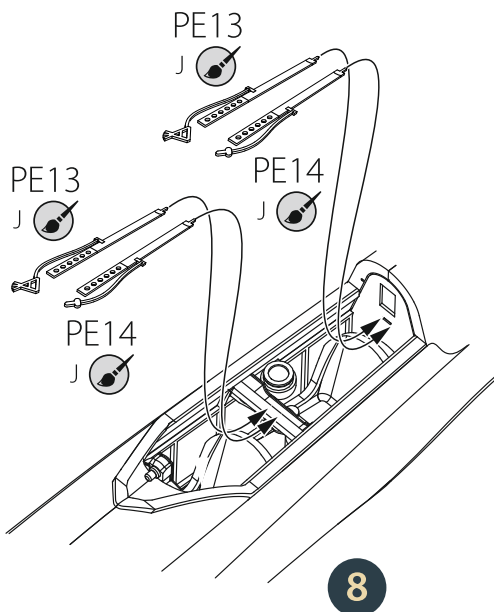

10

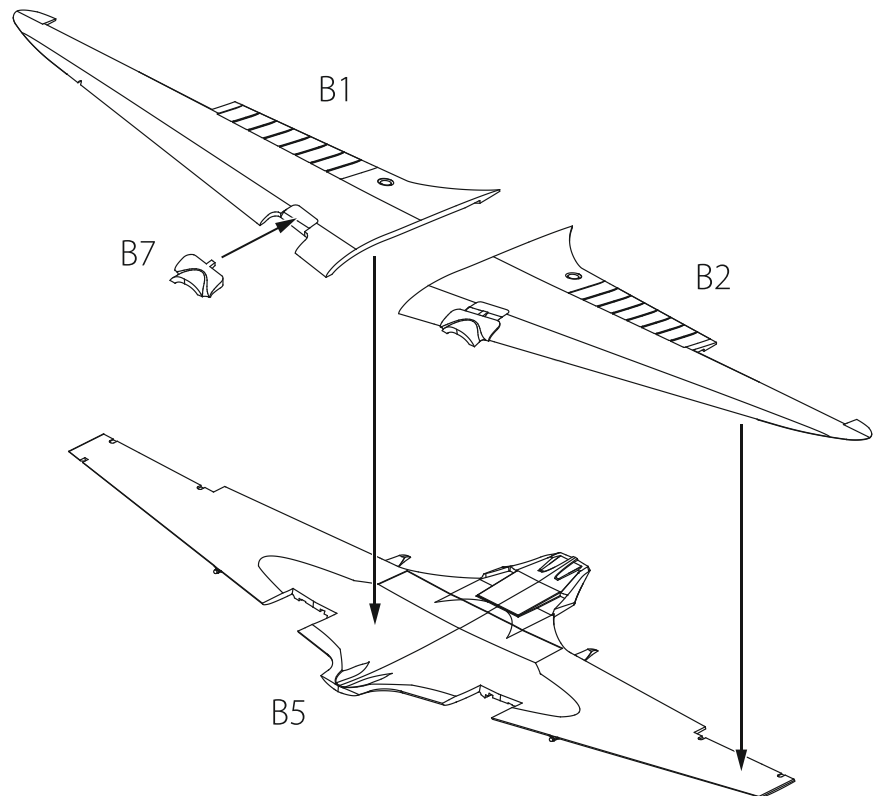

11

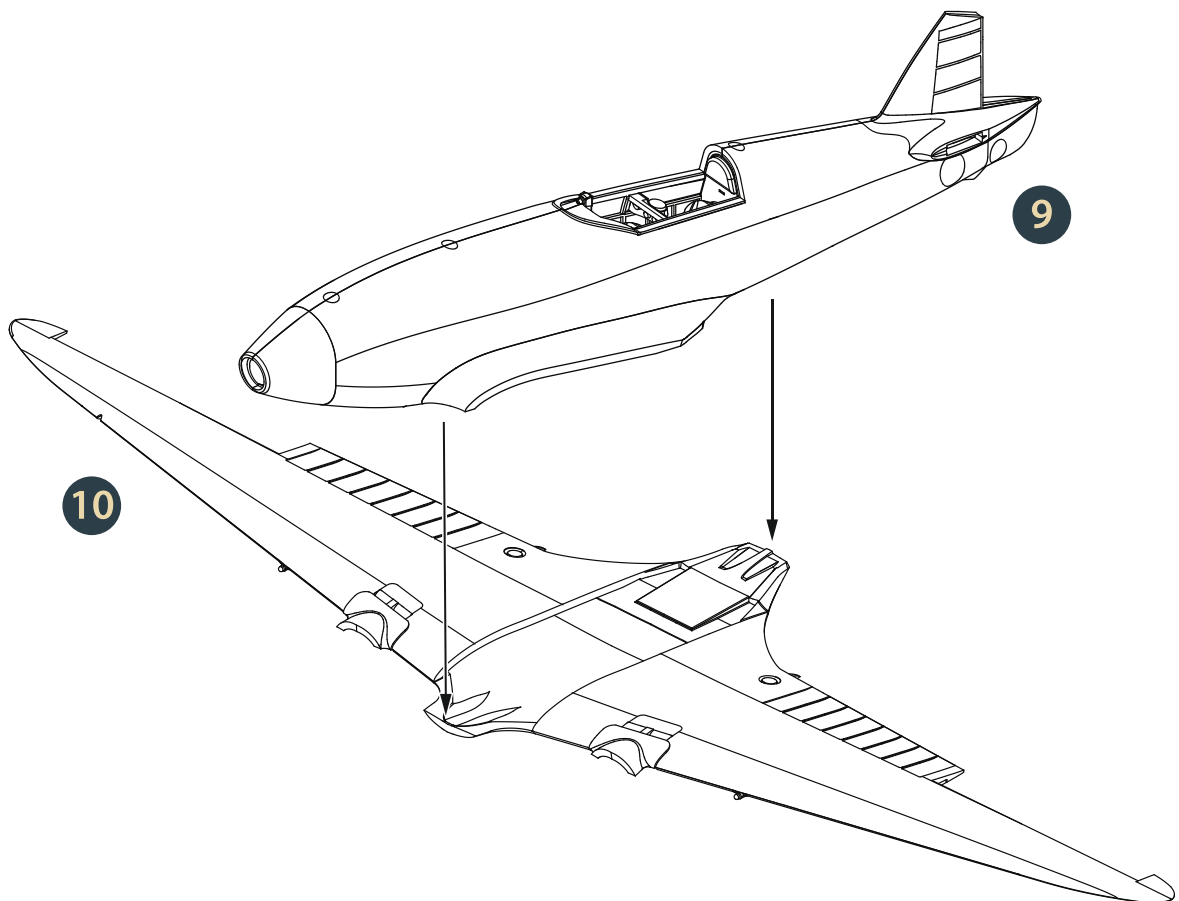

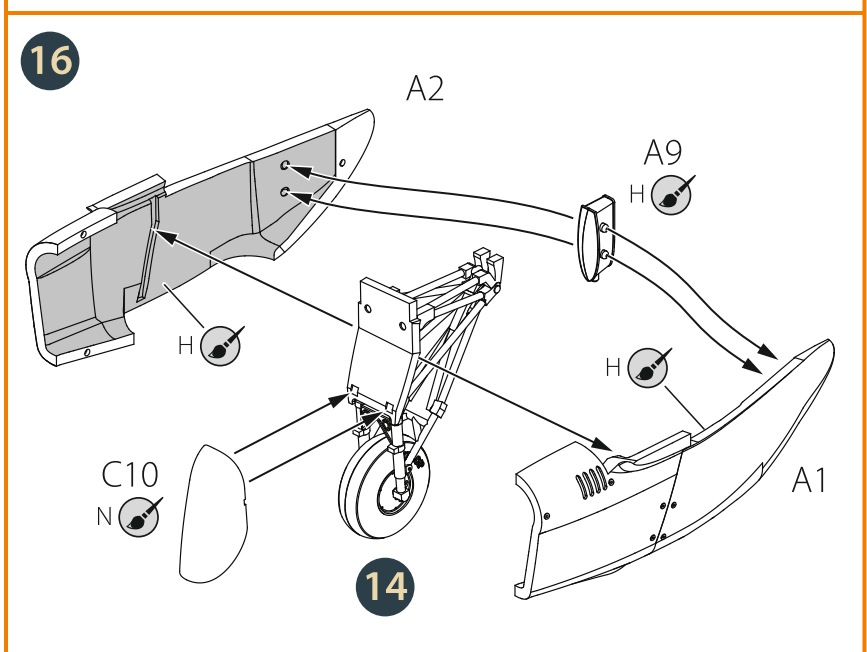
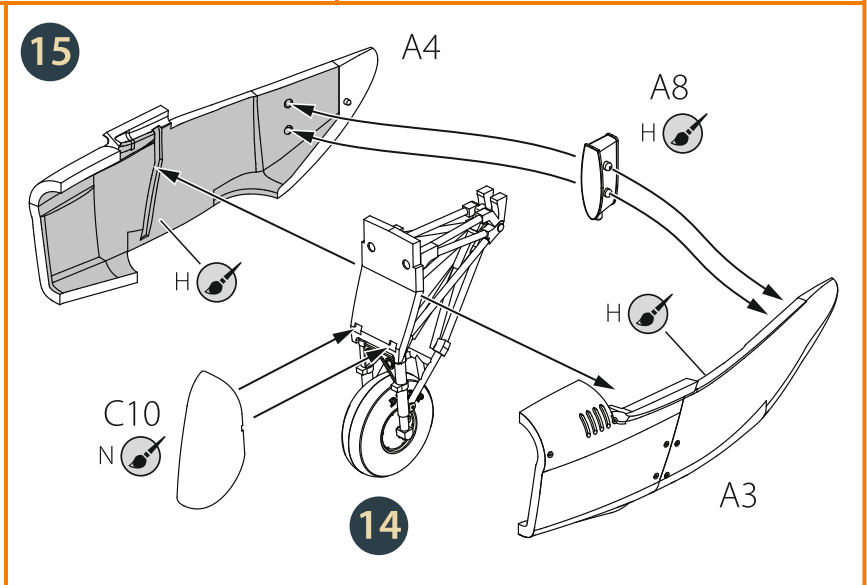
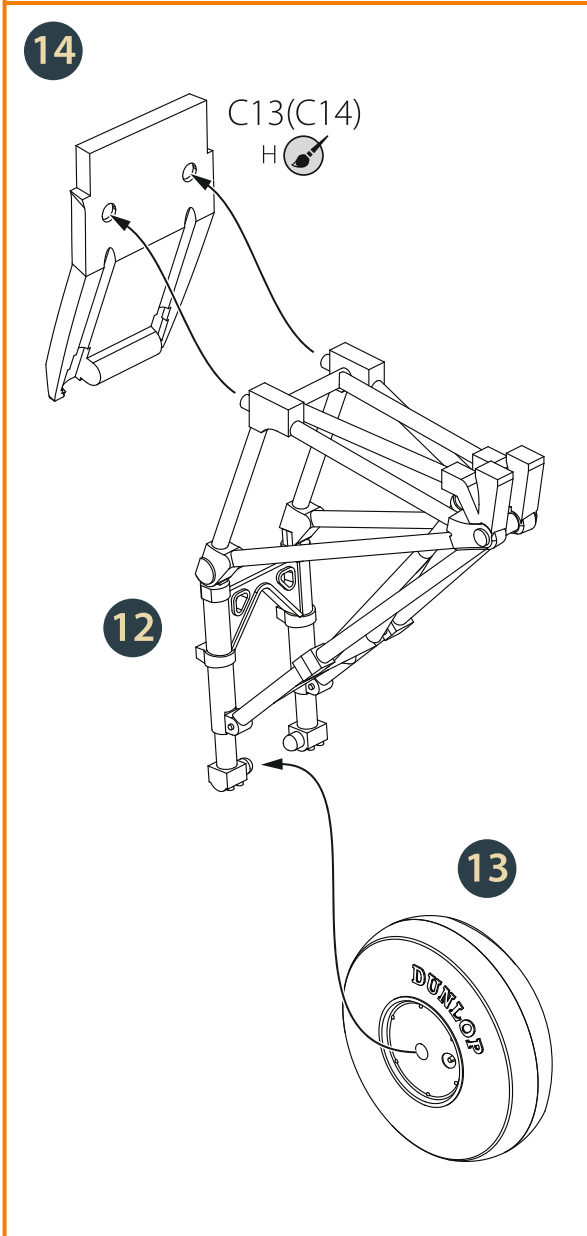
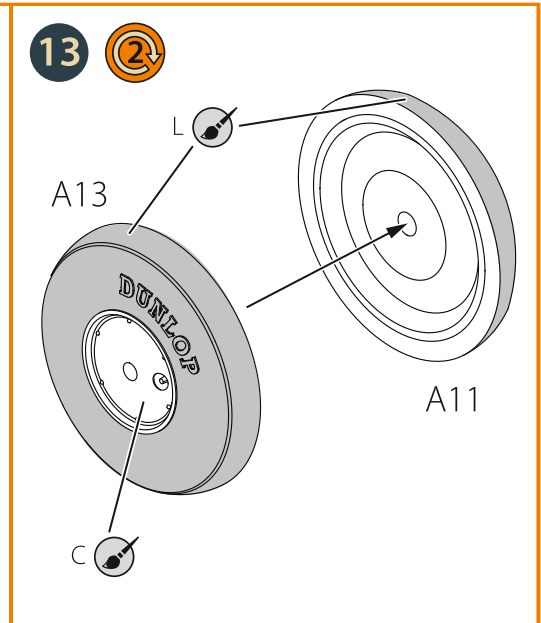
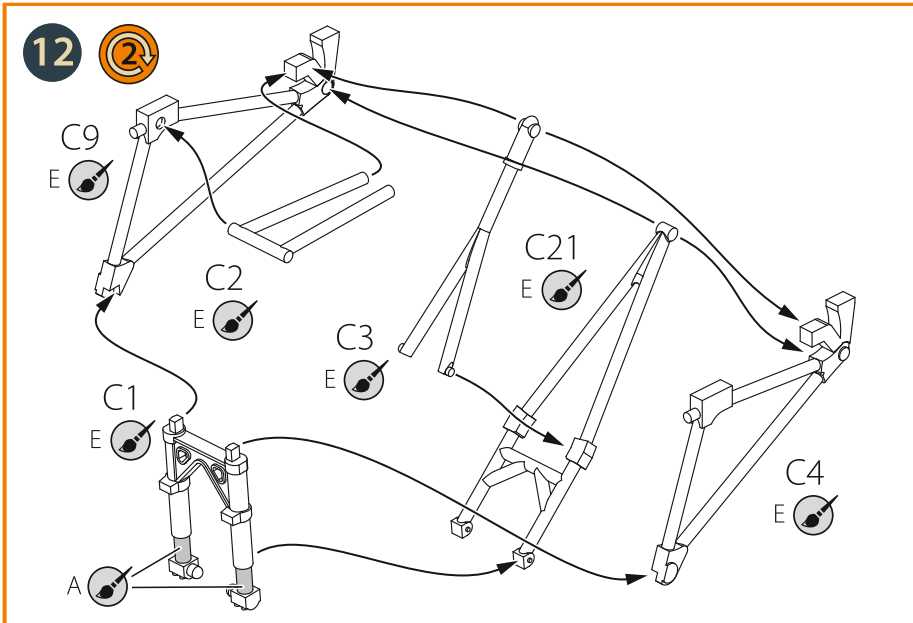

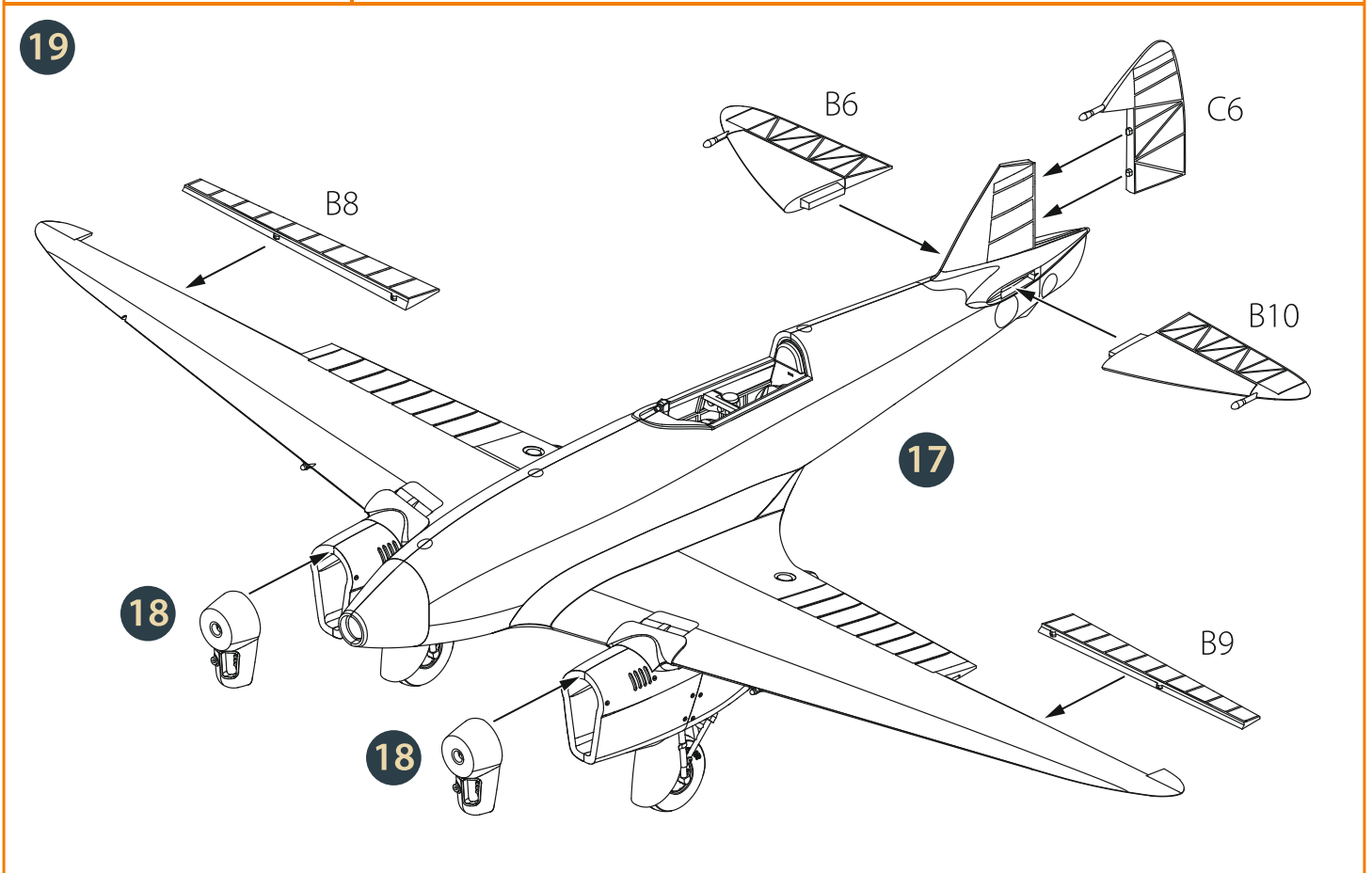
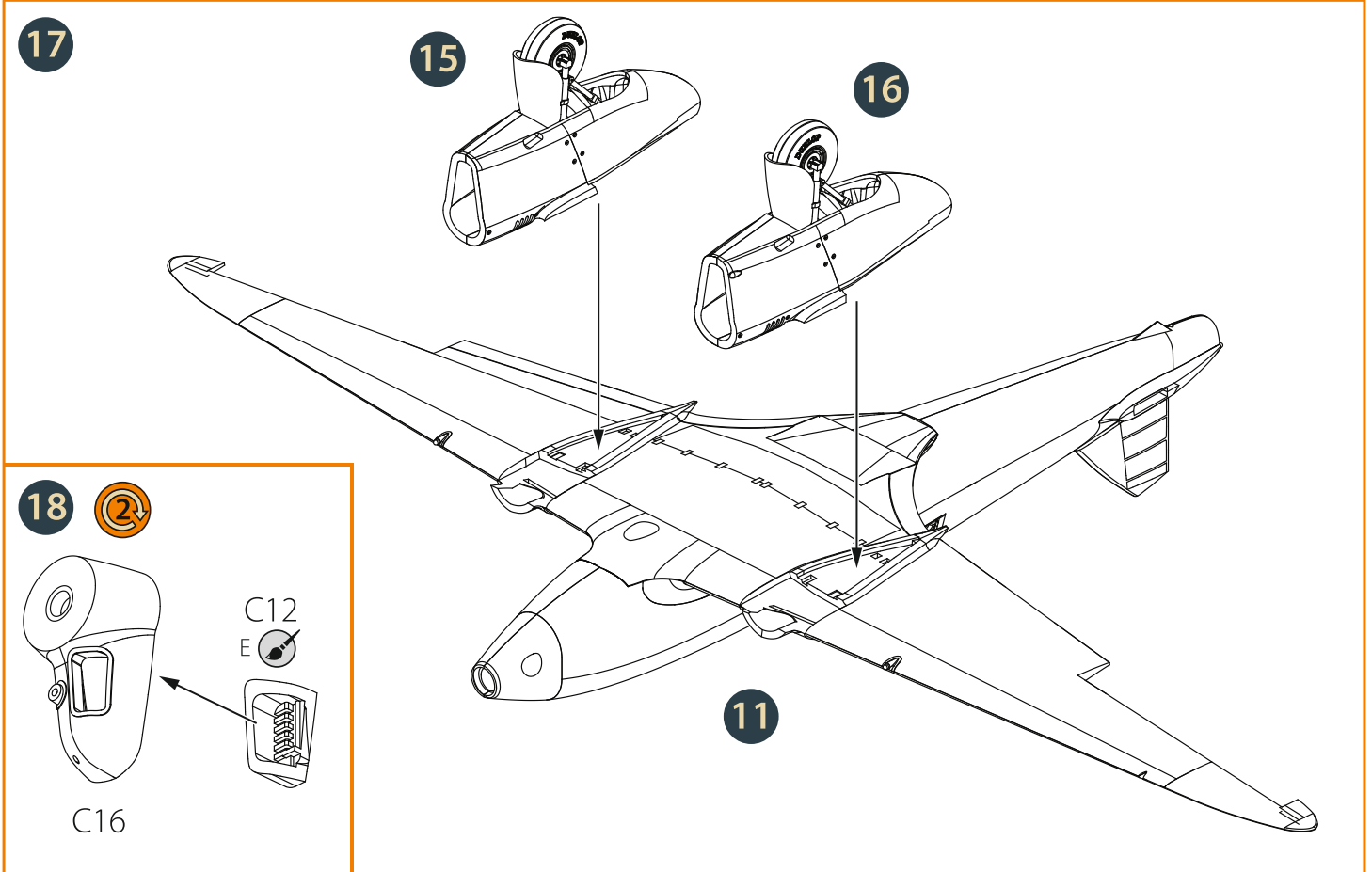

20

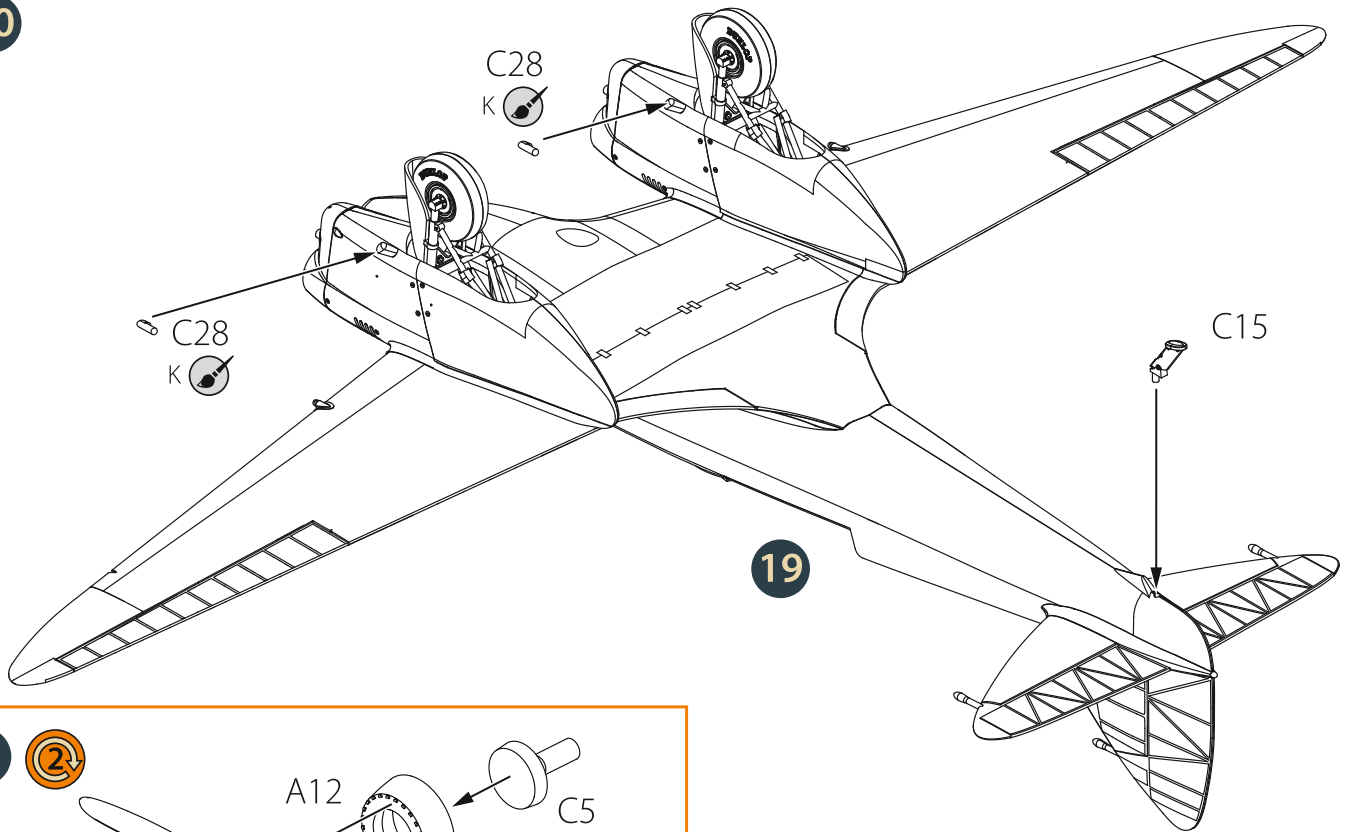

21

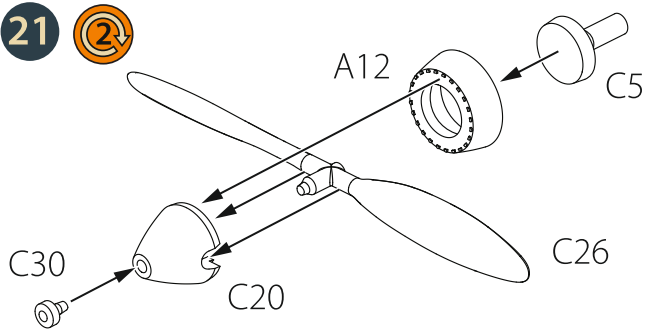

22

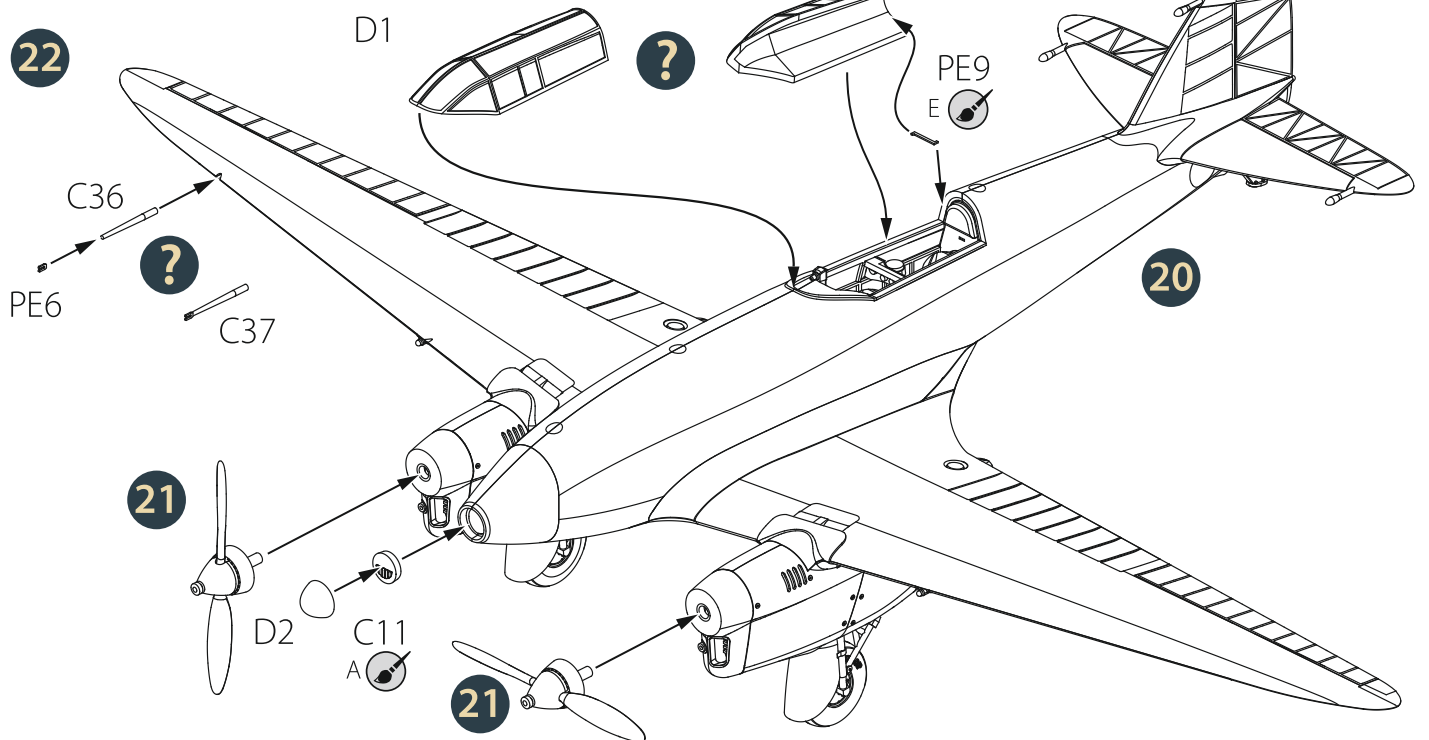



MR. COLOR 8
A.MIG-0195
SILVER



MR. COLOR 3
A.MIG-0049
RED



MR. COLOR 33
A.MIG-0046
BLACK

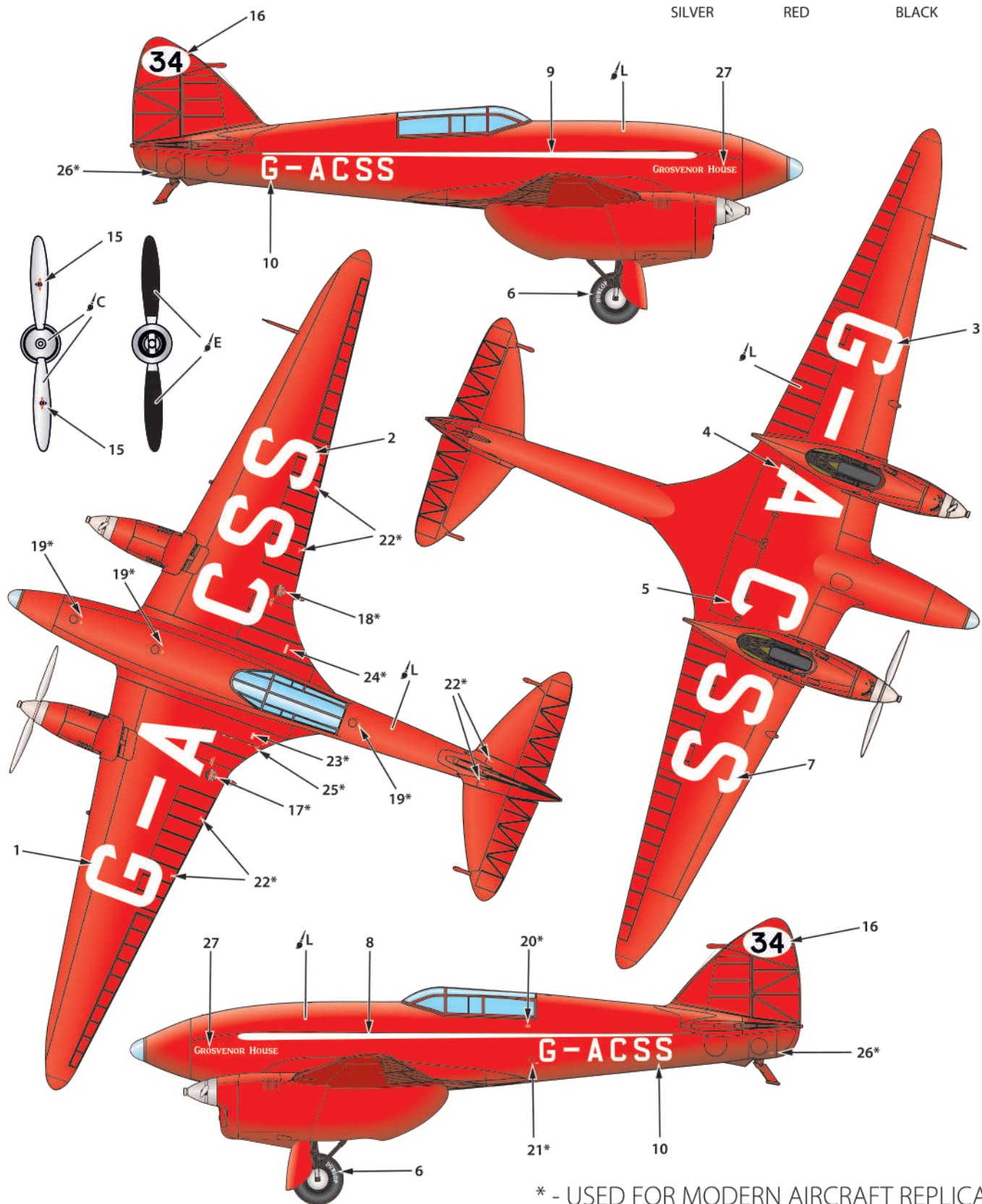

* - USED FOR MODERN AIRCRAFT REPLICA



VISIT OUR SITE FOR MORE SCALE MODEL KITS
clearpropmodels.com

