

**JO-HAN****GC-1300**

# POLICE PURSUIT

**IMPORTANT. READ THIS BEFORE YOU BEGIN.** Read the instructions thoroughly and study the assembly drawings to become familiar with all the parts. After removing the parts from their frames, trim away any excess plastic and check fit before cementing. Build up sub-assemblies without chrome for painting. Use only paint and cement made for styrene plastic. Whenever a chrome-plated part is to be cemented, **SCRAPE OFF CHROME IN AREAS WHICH WILL BE CEMENTED. CEMENT WILL NOT HOLD TO PLATED SURFACES.** Use just enough cement to join parts to avoid smearing on exposed surfaces. Work carefully and patiently. All parts on this instruction sheet are numbered in the order of their assembly. Just FOLLOW THE NUMBERS. NOTE: (C) indicates chrome-plated. To help you build a better model, we have included suggested colors for each of the parts which are not chrome-plated.

## ENGINE ASSEMBLY

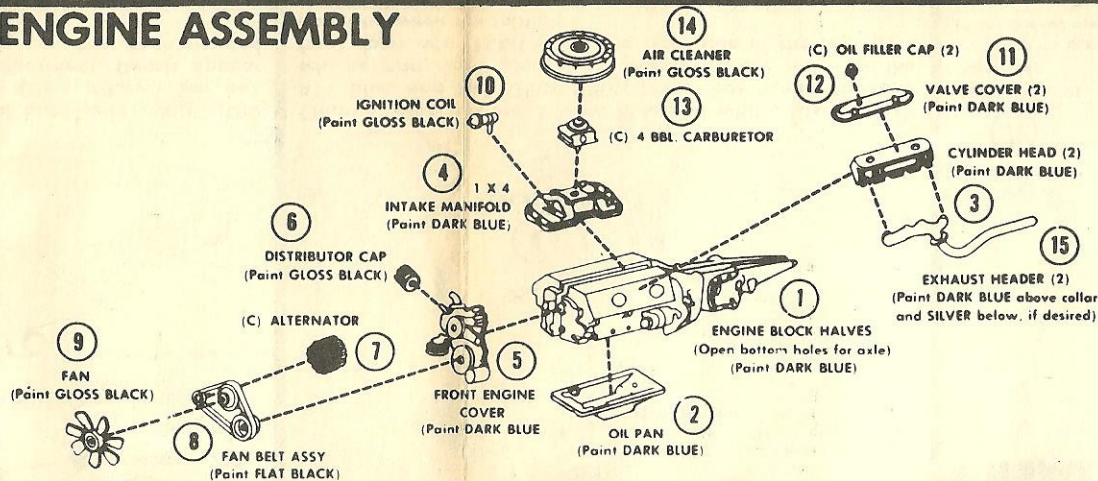

## INTERIOR ASSEMBLY

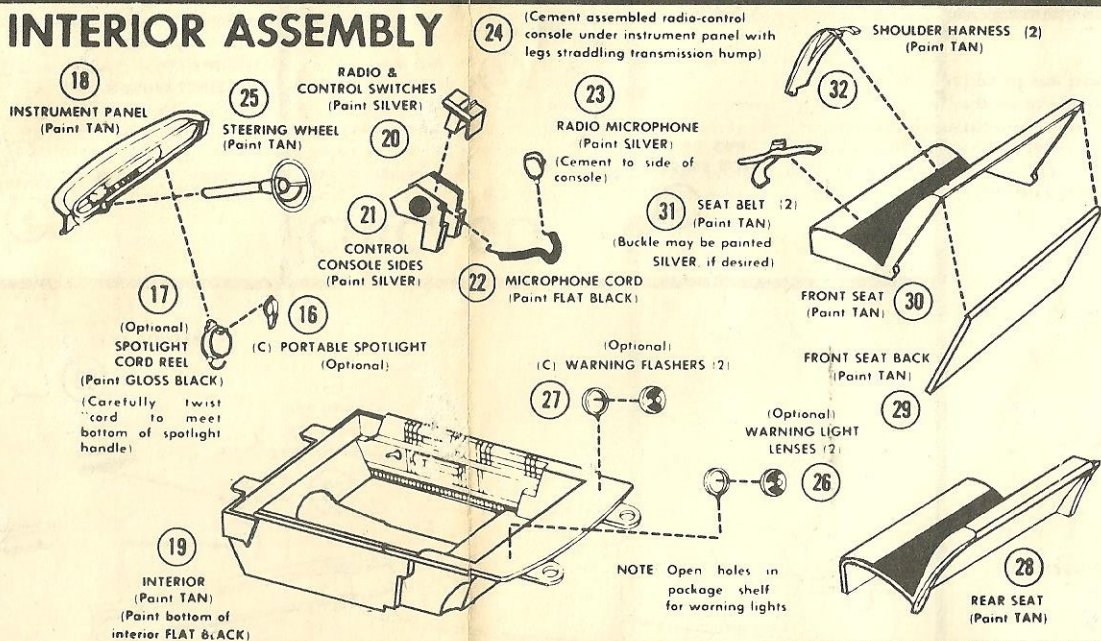

## LOCAL POLICE DEPT. OR SHERIFF ROAD PATROL VERSIONS

With the combination of equipment which we have included in this kit it will be possible for you to reproduce a model police car of your own local police dept. Paint to match the actual colors of your own city or town's police cars. If you wish to make your own decals, simply use "Scotch" or "Mystik" colored tape. These tapes come in a wide variety of colors and widths. Stretch it out on a flat cutting surface. Trace the design on it with a soft pencil and cut out with a sharp X-Acto knife.

If you do not wish to make any of the city police cars, we have also included decals to make a Sheriff Road Patrol version. You may use any combination of equipment you choose. However, sheriff patrol cars usually use the long communications antenna because it has a greater radio range and the cars usually have to patrol an entire county rather than just a certain area of a city.

# CHASSIS ASSEMBLY

**CHASSIS**  
(Paint FLAT BLACK)  
(Exhaust system may be painted SILVER, if desired)



**NOTE** Locate assembled engine into chassis by running front axle thru locators and engine block. May be cemented in position if desired.

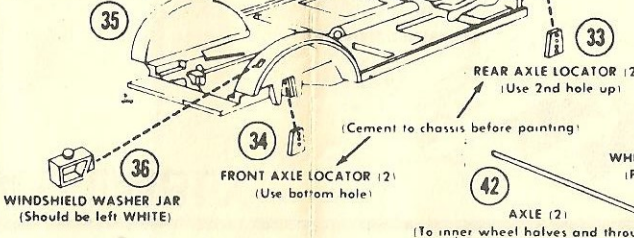

**NOTE** Wheels should be painted as follows: DETROIT - Gloss Black NEW YORK - Testor's #24 Green CHICAGO - Testor's #11 Blue LOS ANGELES - Gloss Black

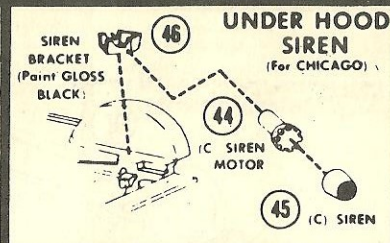

**42** AXLE (2)  
(To inner wheel halves and through axle locators)

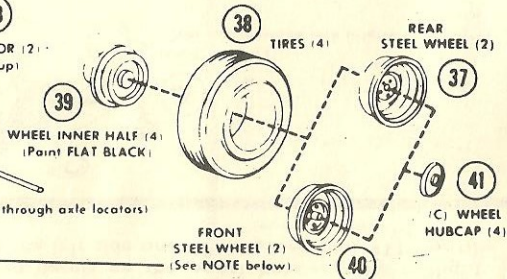

# FRONT BODY ASSEMBLY

**NOTE** Cement Assembled spotlight to windshield pillar post

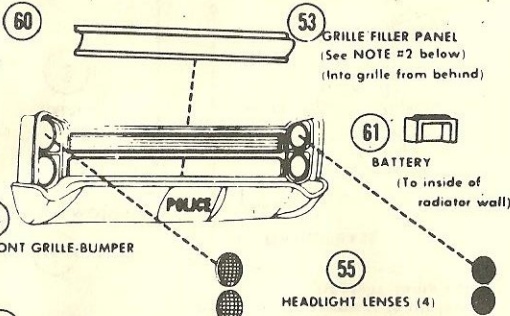
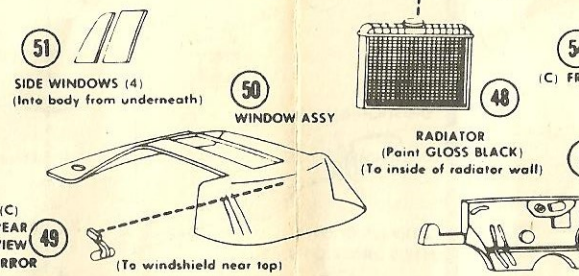
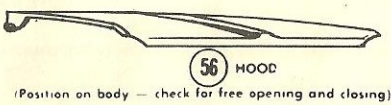
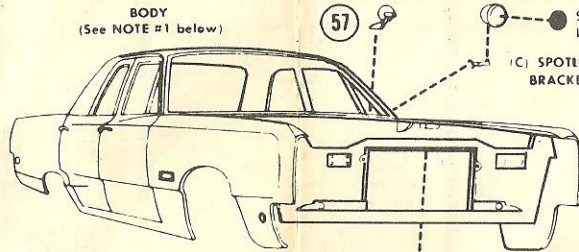

**NOTE #1:** Refer to painting tips for the version you are building, on the other side of this sheet. Open holes in body for required equipment before painting.

**NOTE #2**  
Paint firewall and grille filler panel as follows: DETROIT - Gloss White, NEW YORK - Gloss Black, LOS ANGELES - Gloss Black, CHICAGO - Testor's #11 Blue.  
If you are building a version other than one of these four, paint to match the color of the body in the area forward of the front doors.

To help you achieve a better paint job on the body and hood, we suggest that you first wash them in warm water and mild soap. Rinse and dry them thoroughly with a lint-free cloth. Carefully blow off any dust or lint that may settle on them before painting.

# REAR BODY ASSEMBLY

**67**  
 (C) COMMUNICATIONS ANTENNA  
 (May be positioned on either right or left side of rear deck near back window)

**64**  
 (C) TAILLIGHT FRAME (2)  
 (Into body from underneath)

**65**  
 (C) REAR BUMPER

(C) RADIO ANTENNAS (2)  
**66**

(For DETROIT)

**63**  
 TAILLIGHTS (2)  
 (Clear Red)  
 (Into frames)

NOTE: Open hole in roof for radio antenna — all cities. In addition, open hole in rear deck lid for 2nd Detroit antenna.  
 For Sheriff patrol version, omit these antennas and open hole for communications antenna.

## LOS ANGELES

**4**  
 FLASHER HOUSING HALVES (4)  
 (For 2 flashers)  
 (Paint GLOSS BLACK)

**5**  
 FLASHER LENSES (4)  
 (Clear Red)  
 (For 2 flashers)

**3**  
 (C) SIREN MOTOR COVER

**2**  
 (C) SIREN

**1**  
 NOTE: Open holes in roof marked "LA"

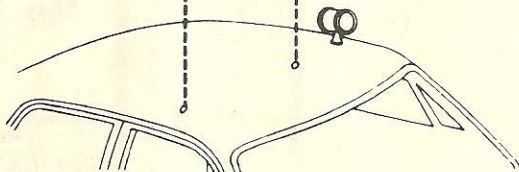

Los Angeles police cars are painted black and white. (Use Testor's #47 Gloss Black and #45 Gloss White.) See box cover for color scheme and decal placement. Decals appear only on the front doors and "925" on the double-ended flashers.

## CHICAGO

**5**  
 FLASHER DOME  
 (Clear Blue)

**2**  
 (C) FLASHER LAMP

**3**  
 (C) FLASHER BASE

**1**  
 NOTE: Open hole in roof marked "CH" and insert locator pin.

**4**  
 LOCATOR PIN

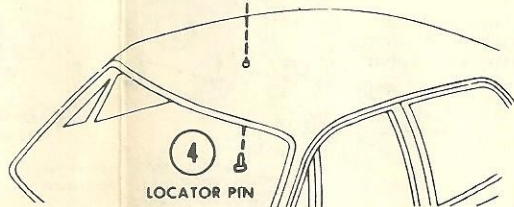

Chicago police cars are painted blue and white. (Use Testor's #11 Blue and #45 Gloss White.) See box cover for color scheme and decal placement. Decals appear only on the front doors and "POLICE" on the right side of the rear deck panel between the taillights.

# DETROIT

NOTE: Siren parts may be painted **FLAT BLACK**, if desired.

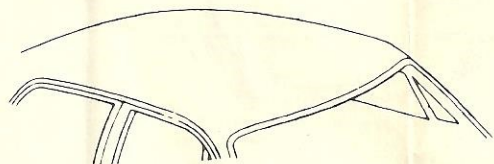
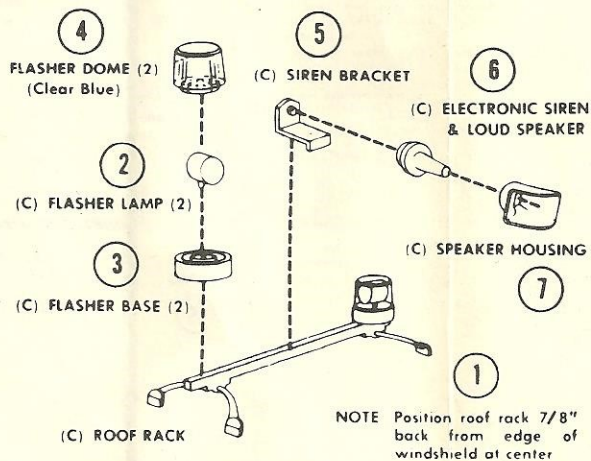

Detroit Tactical Mobile Unit cars are painted blue and white. (Use Testor's #8 Blue and #45 Gloss White.) See box cover for color scheme and decal placement. In addition, there is a wide blue band running across the top from the tip of the hood to the rear bumper with a "70" decal at the tips of the hood and the rear deck.

# NEW YORK

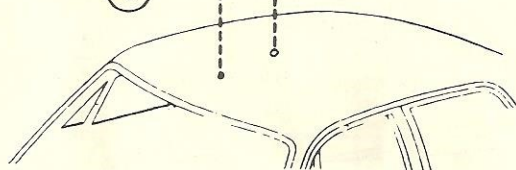
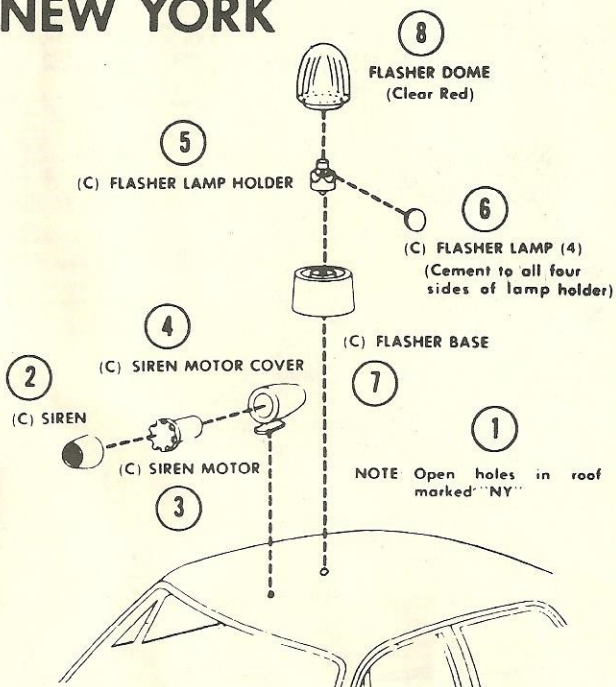

New York police cars are painted black, green and white. (Use Testor's #47 Gloss Black, #24 Green and #45 Gloss White.) See box cover for color scheme and decal placement. In addition, the rear deck from the back window down between the taillights to the rear bumper is painted white. There are two decals on the panel between the taillights. "POLICE" on the left side and "Emergency Dial 911" on the right side.

# FINAL ASSEMBLY

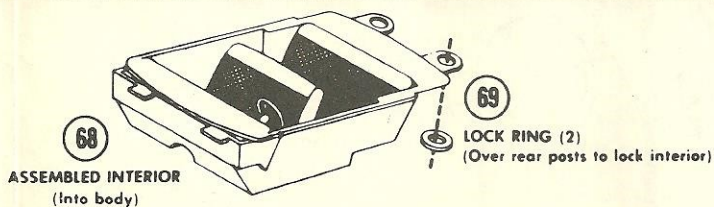

72 PUSH BAR FRAME  
(Optional)  
(Paint **FLAT BLACK**)  
(Cement to chassis)

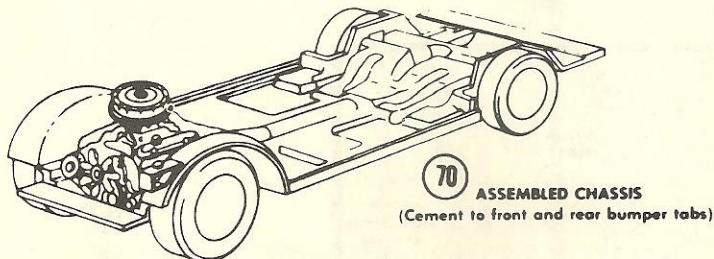

71 PUSH BARS (2)  
(Optional)  
(Paint **GLOSS BLACK**)  
(Paint padded area **FLAT BLACK**)

