

Junkers Ju 87D-5

1/72

CZ

V rámci budování Luftwaffe ve třicátých letech dvacátého století se jednou z nejvýznamnějších kategorií letadel zavedených do výzbroje staly střemhlavé bombardéry. Soutěž o nový typ bombardéru nazvaný Sturzkampfflugzeug, zkráceně Stuka vyhrála firma Junkers se svým typem Ju 87A. Jméno kategorie se přeneslo na nový typ, bojově nasazený ve Španělské občanské válce. Jinak sloužil k výcviku. U bojových jednotek je nahradily verze Ju 87B a R, které na začátku druhé světové války prožily svou hvězdnou hodinu. Až bitva o Británii ukázala, že Ju 87B nebo jeho dálkové varianty Ju 87R jsou, bez mocné ochrany stíhaček, velmi zranitelné. Luftwaffe ale nutně potřebovala letouny této kategorie. Navíc v obrovských prostorech východní fronty nebyla stíhací ochrana tak nutná, protože i stíhačky protivníka byly rozptýleny. Proto bylo pokračováno ve vývoji. Nová verze Ju 87D byla aerodynamicky zjemněna, chladič byl rozdělen na dva a umístěn pod křídlo. Nový byl i překryt kabiny a pancéřováním, střelec dostal k ochraně zadní polosféry dvojkulomet MG81Z. K pohonu byla vybrána výkonnější varianta motoru Jumo 211J. Díky tomu nosnost pum vzrostla téměř čtyřikrát. Verze Ju 87D byla vyráběna v řadě subverzí od verze Ju 87D-1 až po Ju 87D-8. Verze Junkers Ju 87D-5 dostala prodloužené křídlo a kulometry v křídle byly nahrazeny účinnějšími kanóny MG 151 ráže 20 mm. Ju 87D byly používány jako střemhlavé bombardéry, vlekače kluzáků a bez brzd střemhlavého letu jako bitevní a noční bombardéry. V těchto rolích vydržely Stuky až do konce války a to nejen v Luftwaffe. Junkersy Ju 87D se dostaly do výzbroje letectev Itálie, Rumunska, Maďarska, Slovenského Štátu a Bulharska. Po přechodu některých uživatelů na spojeneckou stranu byly Stuky použity i proti německým vojskům. Poslední sériovou verzí se stala verze Ju 87G. Ta na verzi D navázala, ale byla vyzbrojena protitankovými kanóny a určena k boji s nepřátelskými tanky.

rozpětí: 15,00 m, délka: 11,50 m, max. rychlost: 400 km/h ve výšce 4100 m, dostup: 7500 m, max. dolet: 1530 km, max. nosnost pum: 1800 kg

EN

During the building of the Luftwaffe, dive bomber aeroplanes became one of the most important categories of aircraft introduced to service. The competition for a new type of bomber called the Sturzkampfflugzeug, or shortened Stuka, won Junkers company with their Ju 87A type. The name of the category transferred to the new type, which was first military deployed in the Spanish Civil War but aside from that was only used in the training role. In combat units, the first versions of the Stuka were replaced by the 87B and 87R versions, which at the beginning of the Second World War enjoyed their finest hour. Only the Battle of Britain clearly showed that the Ju 87B or the long range 87R variety are extremely vulnerable aeroplanes when left without escort fighters. Nevertheless, the Luftwaffe desperately needed aircraft of this category. On top of that, in the vast areas of the Eastern Front, the fighter aircraft protection was not much necessary as the enemy fighters were quite scarce. So, the development of the type went on. The new version, named the Ju 87D, featured refined aerodynamics, the engine radiator was split in two and repositioned under the wings. The canopy of a different style was also fitted with armoured glass and the rear gunner was armed with a twin MG81Z machine gun to protect the rear hemisphere. The D version was equipped with a more powerful Jumo 211J engine which almost four times increased the bomb payload. The Ju 87D type was produced in a number of sub-varieties, ranging from the Ju 87D-1 to D-8. The D-5 featured wings with extended span and the wing machine guns were replaced by 20mm MG151 cannon with heavier punch. The Ju 87D was used in the dive bomber role, to tow military gliders, and also flew as a night bomber or a ground attack aircraft – in this instance with the dive brakes removed, and these two latter were the roles in which the Stuka went on serving until the end of the war. And not just with the German Luftwaffe, as the type was also operated by the military of Italy, Rumania, Hungary, Bulgaria and the Slovak State. When some of these countries switched the side, their Stukas were also used even against German forces. The final version to see the service was the Ju 87G, basically a follow up to the D version, differing in the anti-tank underwing cannon under each wing.

Span: 15.00 m, length: 11.50 m, maximum speed: 400 km/h at 4,100 m, ceiling: 7,500 m, max.range: 1,530 km, max. bomb payload: 1,800kg

PLASTIC PARTS

A

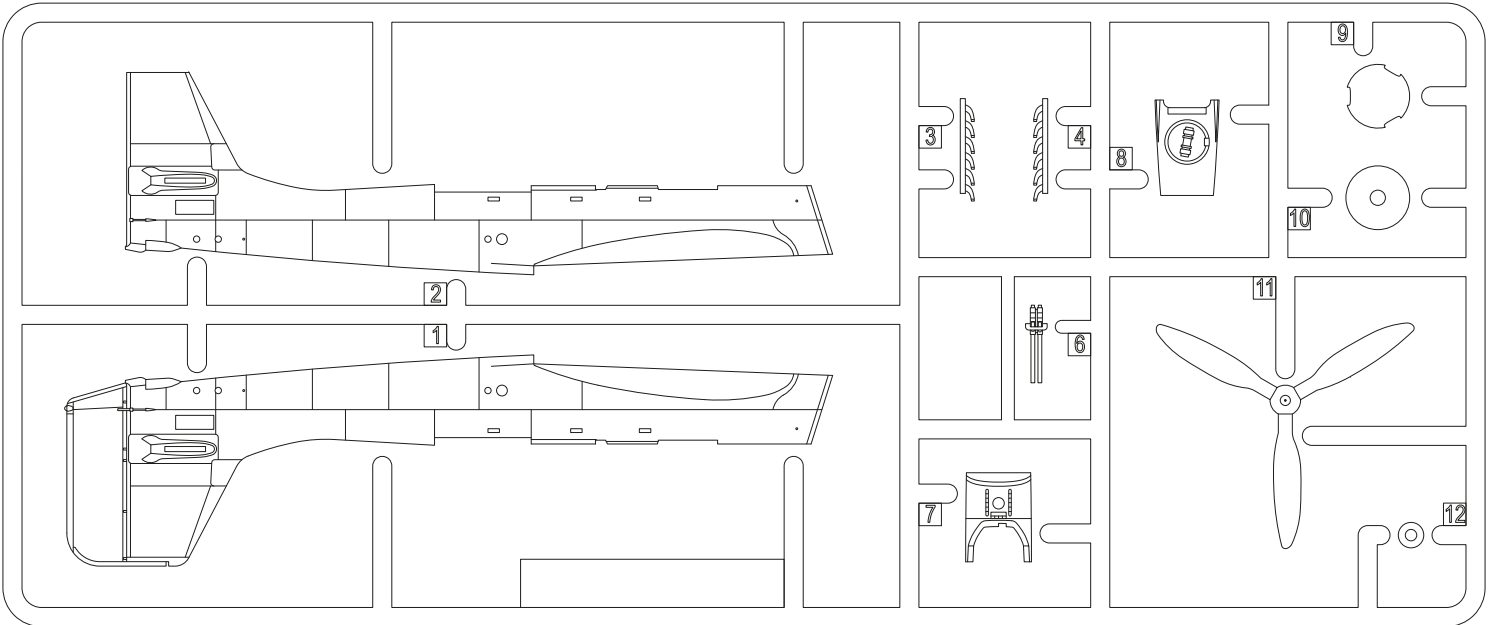

B

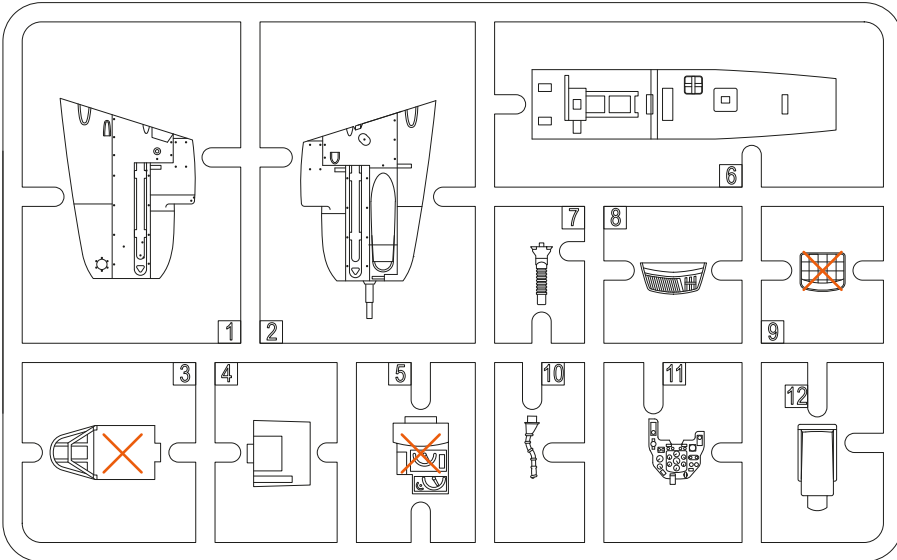

C

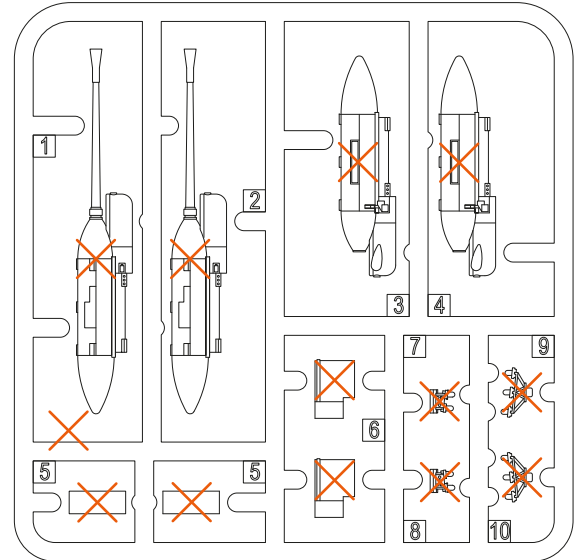

D

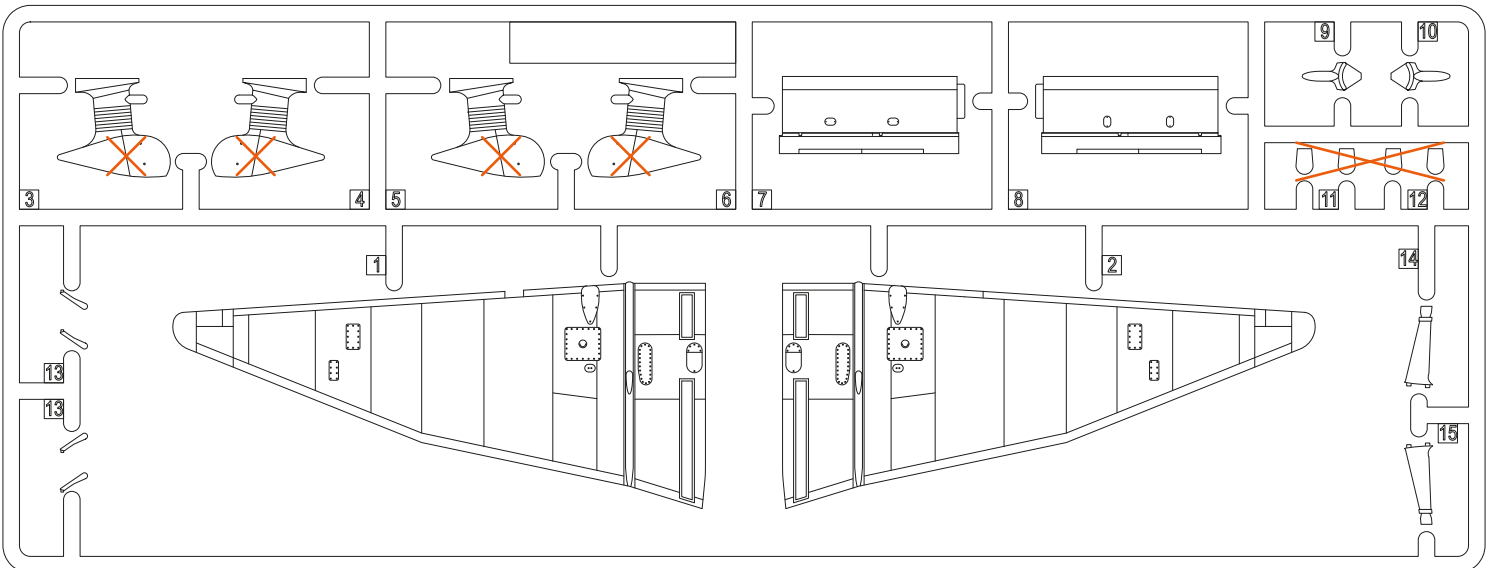

SYMBOLS



MOŽNOST VOLBY
OPTIONAL
NACH BELIEBEN
OPTION



POUŽÍŤ KYANOAKRYLÁTOVÉ LEPIDLO
INSTANT CYANOACRYLATE GLUE
ZYANOAKRYLÁTKLEBER
COLLE CYANOACRYLAT



OHNOUT
BEND
BIEGEN
COURBER



ZHOTOVIT NOVÉ
SCRATCH BUILD
FERTIGSTELLEN
ACHEVER



ŘEZAT/VRTAT
CUT OFF/DRILL
ENTFERNEN
DETACHER



GSI
colour code

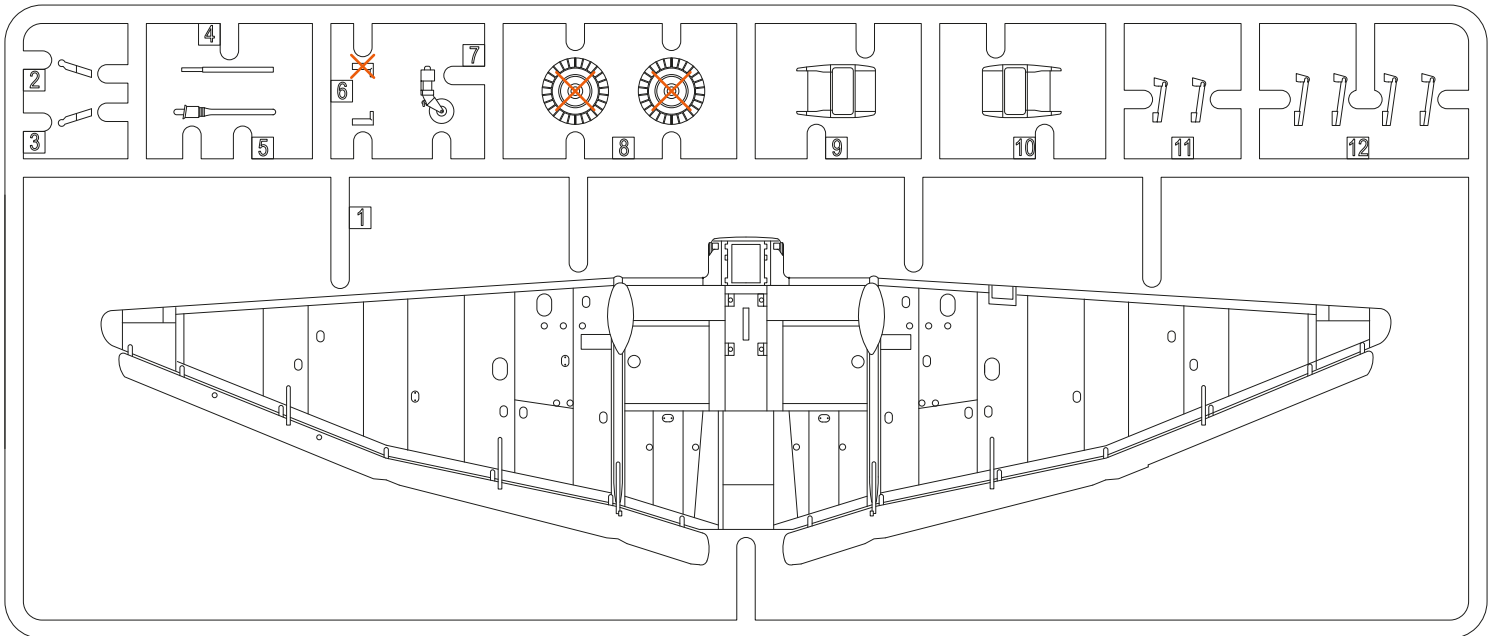
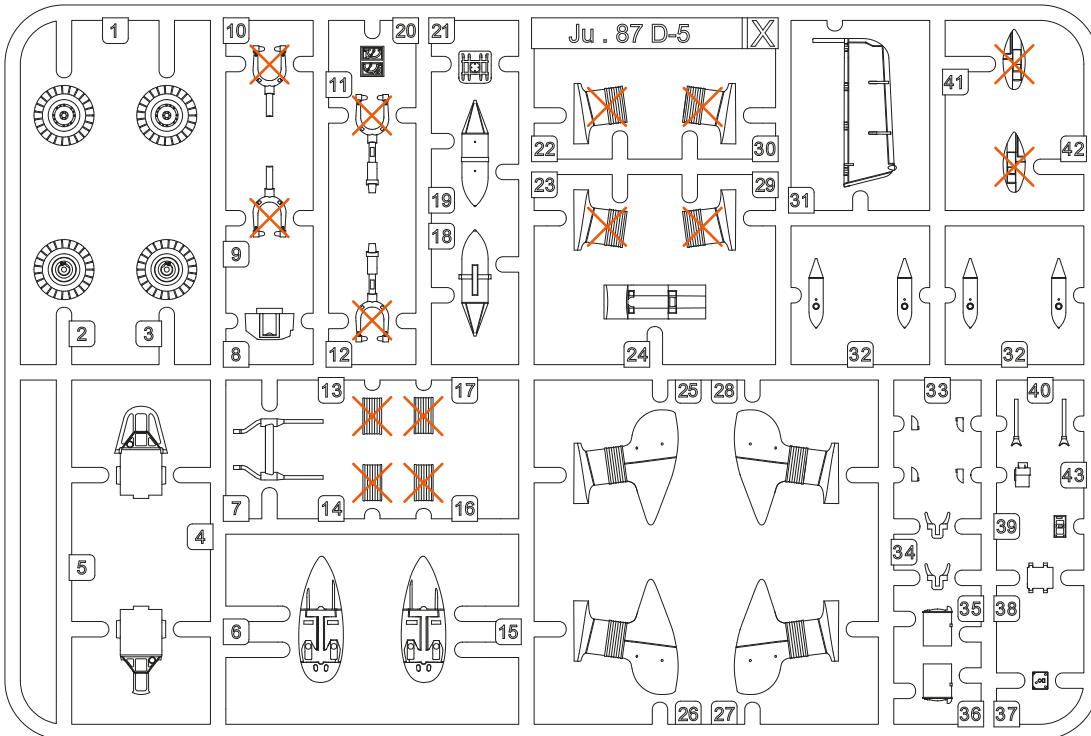
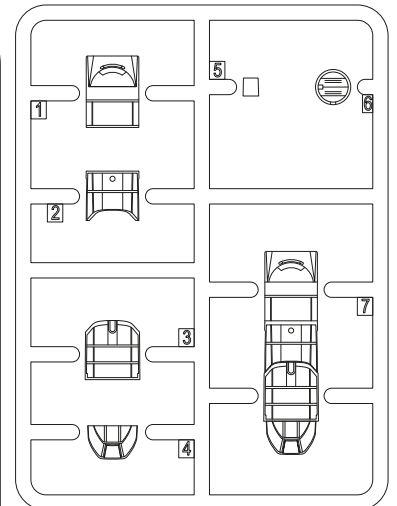
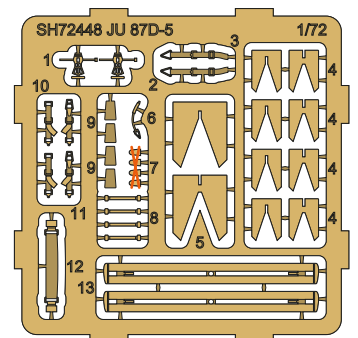

NATRÍT
COLOUR
FARBEN
PEINDRE

E**PLASTIC PARTS****X****F CLEAR PARTS****PHOTO-ETCHED PARTS (PP)**

✗ *Tento díl nepoužít*
Do not use this part

Barvy GUNZE/ GUNZE Colour No.

A Černá / Black	H2 / C2	I Tmavá zelená / Dark Green RLM 71	H64 / C17
B Barva pneu / Tire Black	H77 / C137	J Černo zelená / Black Green RLM 70	H65 / C18
C Hliník / Aluminium	H8 / C8	K Světlá modrá / Light Blue RLM 65	H67 / C115
D Tmavý kov / Dark Iron	MC214	L Šedá / Grey RLM 75	H69 / C37
E Opálený kov / Burnt Iron	H76 / C61	M Žlutá / Yellow RLM 04	H413 / C113
F Červeno hnědá / Red Brown	C131	N Červená / Red	H3 / C3
G Barva plátna / Tan	H27 / C44	O Bílá / White	H1 / C1
H Šedá RLM 66 / Grey RLM 66	H416 / C116	P Zelená / Green	H6 / C6

STEP 1

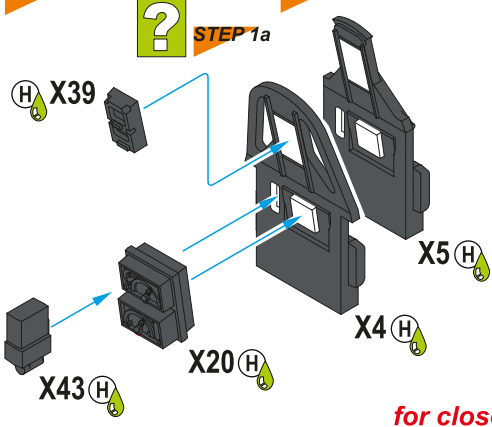

STEP 1b



STEP 1a

STEP 2

2x STEP 2a

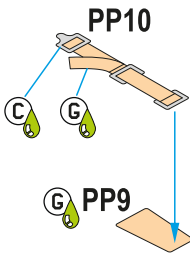

STEP 2b

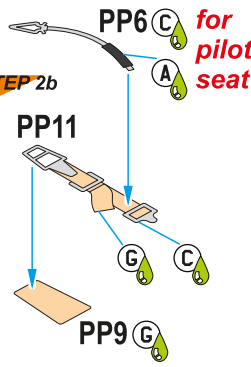

STEP 3

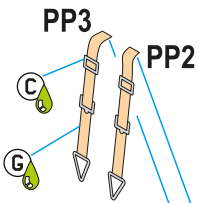

STEP 2a

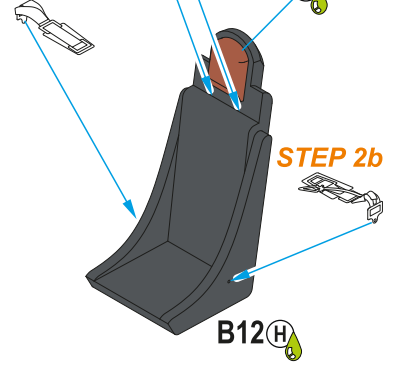

STEP 2b

for close cabin-p.9
STEP 1b

for open cabin-p.9
STEP 1a

STEP 5

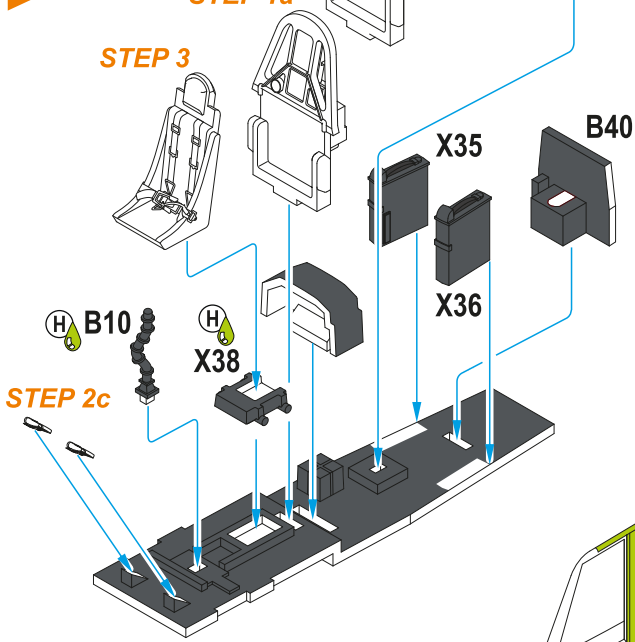

STEP 4

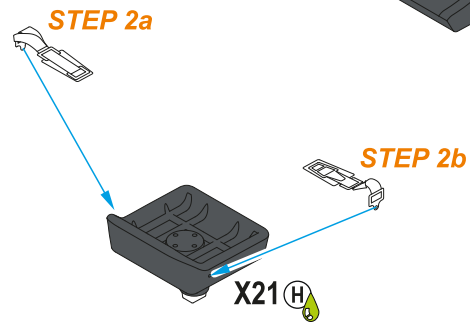

STEP 2a

STEP 2b

STEP 7

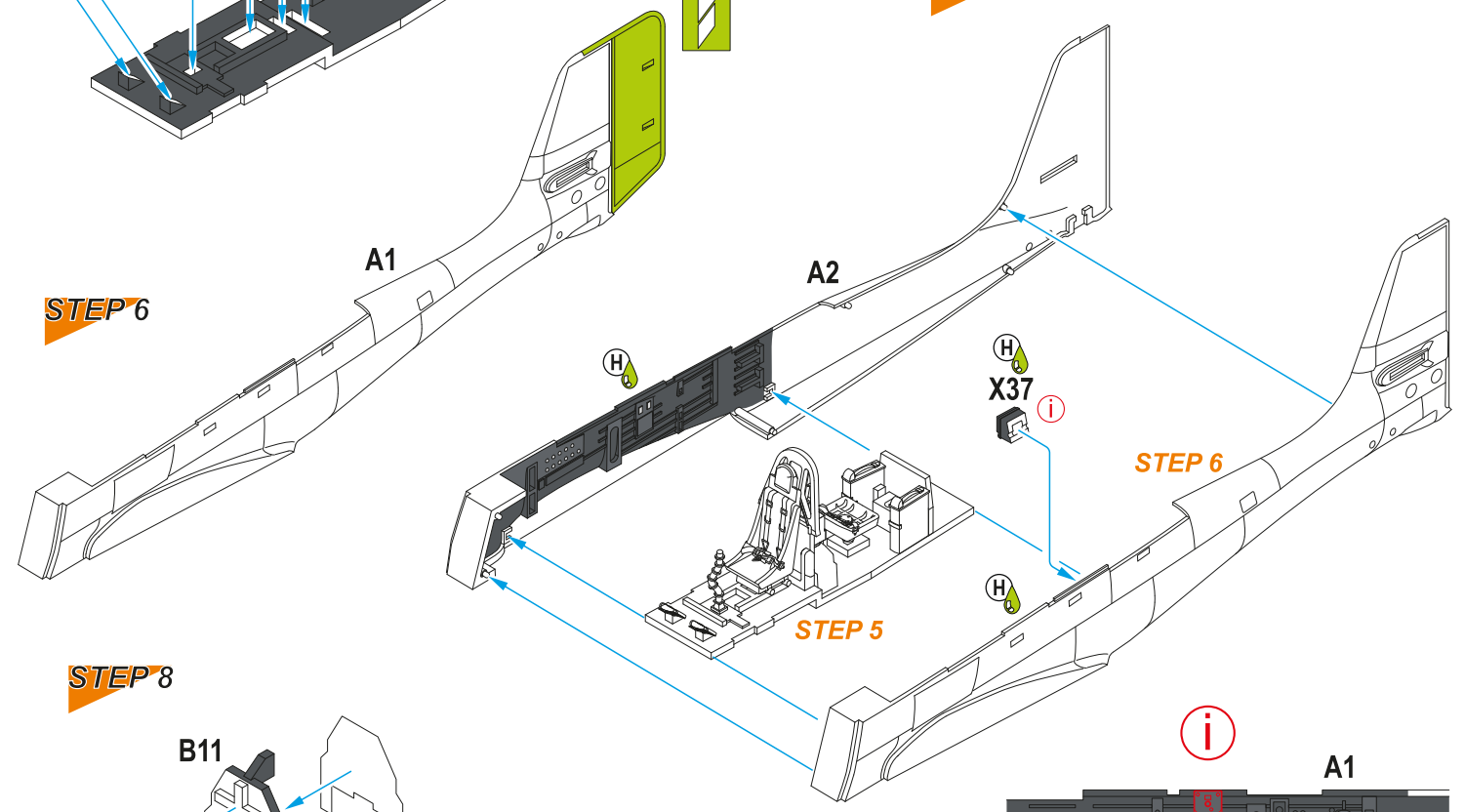

STEP 6

STEP 5

STEP 8

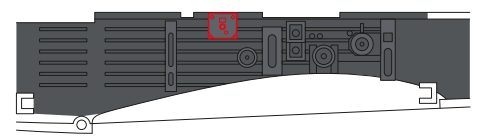
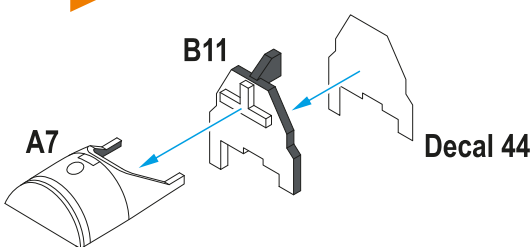

STEP 9

F6
H
C

A8

STEP 8

STEP 7

STEP 9

STEP 11

STEP 10

STEP 14

D2

D1

STEP 13

STEP 12

STEP 10

E A3

B2

B8

B1

E A4

STEP 12

X34

X34

X24

STEP 13

E1

 for parts X24+X34

STEP 15

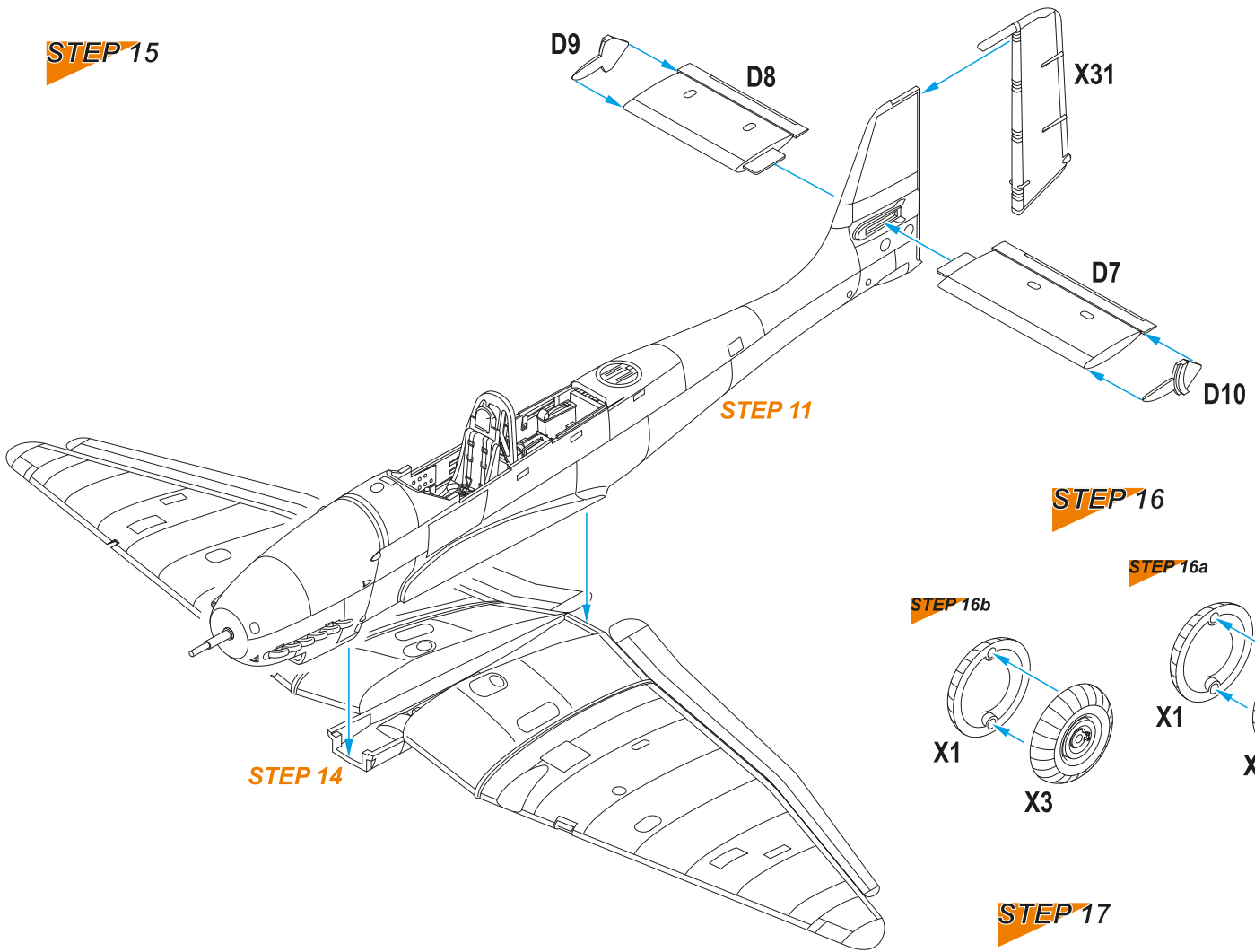

STEP 16

STEP 16a

STEP 16b

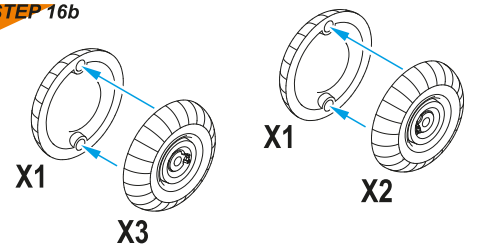

STEP 17

STEP 17a

STEP 16a



STEP 17b

STEP 16b

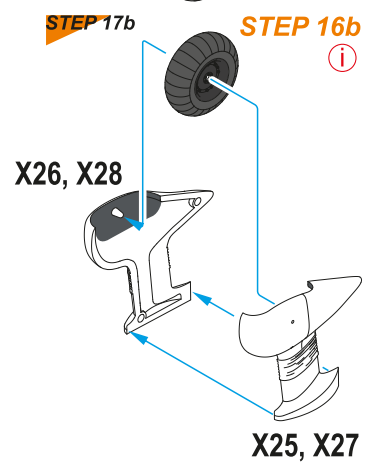

STEP 18

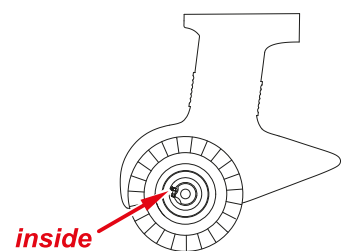
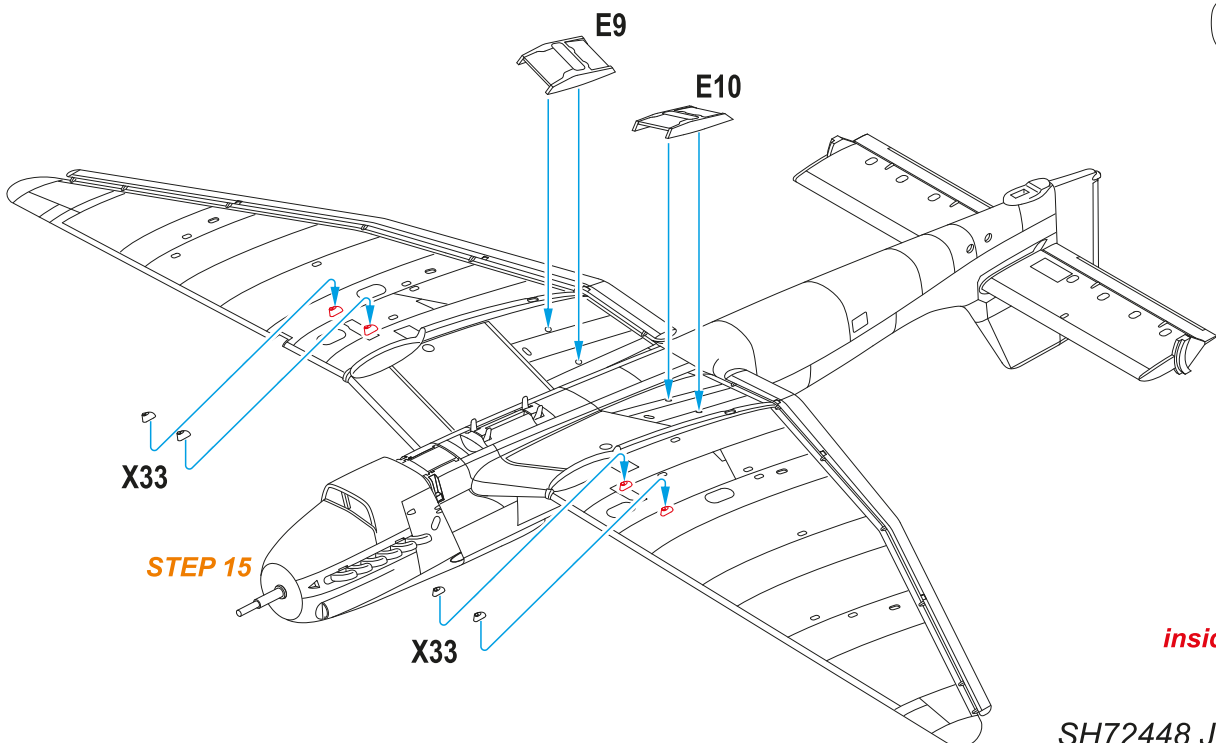
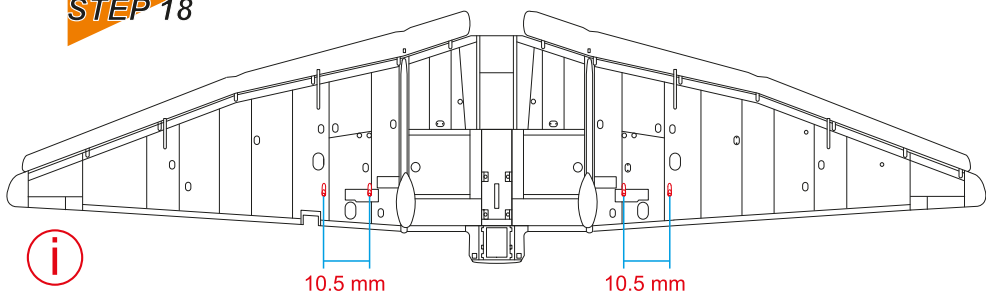

STEP 19

STEP 16a

STEP 16b

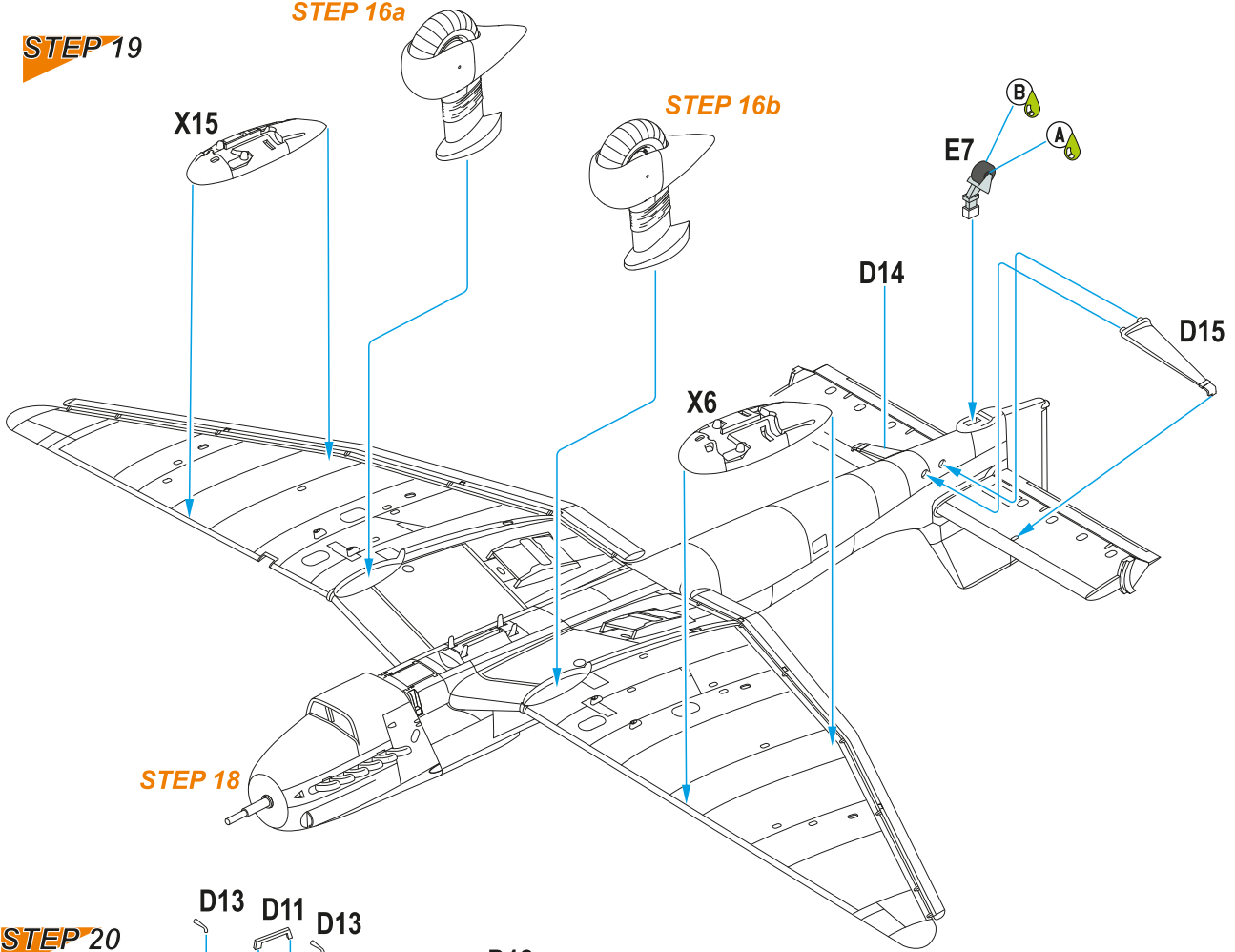

STEP 18

STEP 20

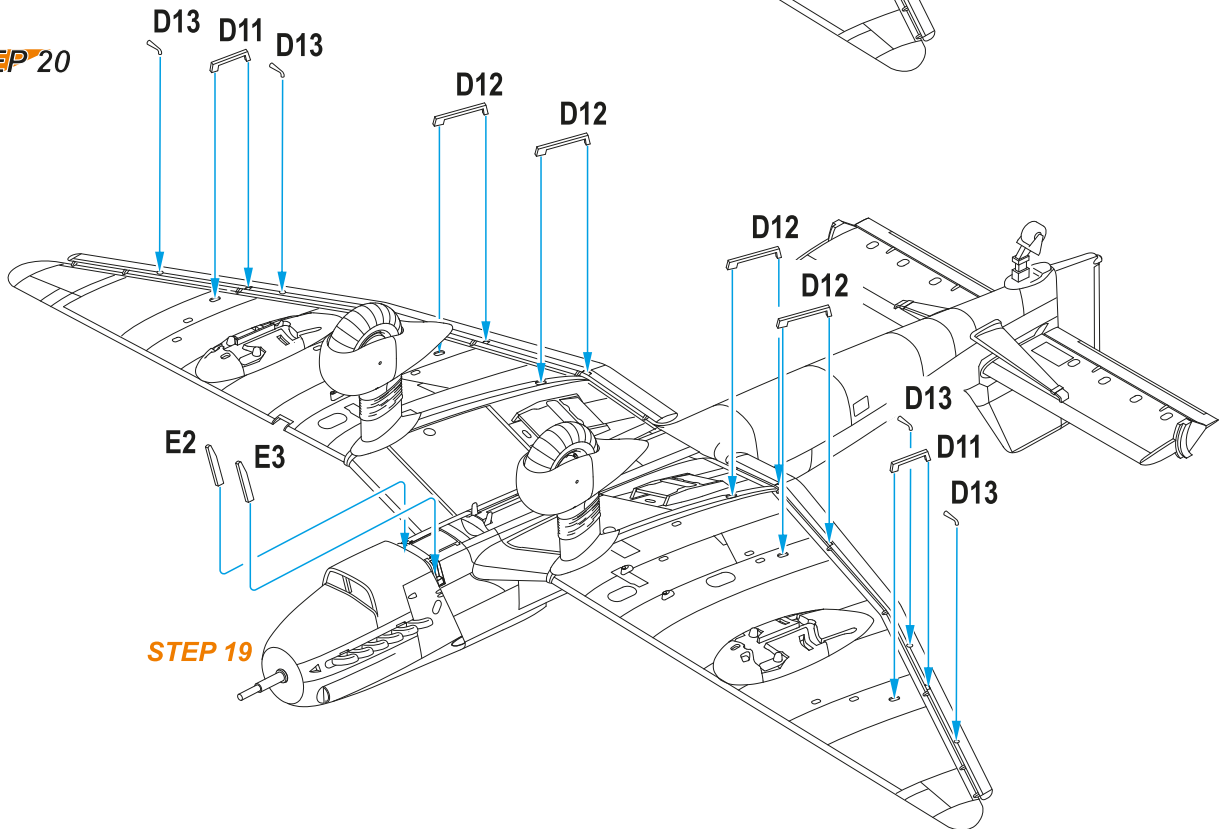

STEP 19

STEP 21

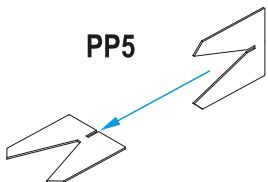

STEP 22

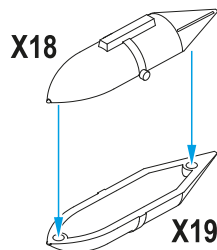

STEP 23

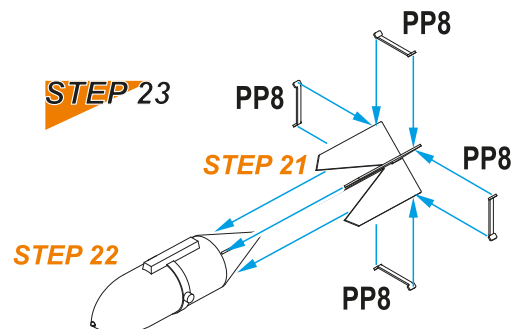

STEP 24

4x

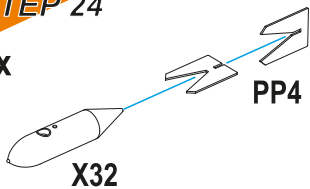

STEP 25

2x

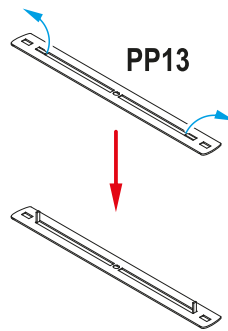

STEP 26

STEP 24

STEP 23

STEP 24

STEP 25
B, C, D
schemes
only

STEP 20

STEP 25
B, C, D
schemes
only

STEP 27

STEP 26

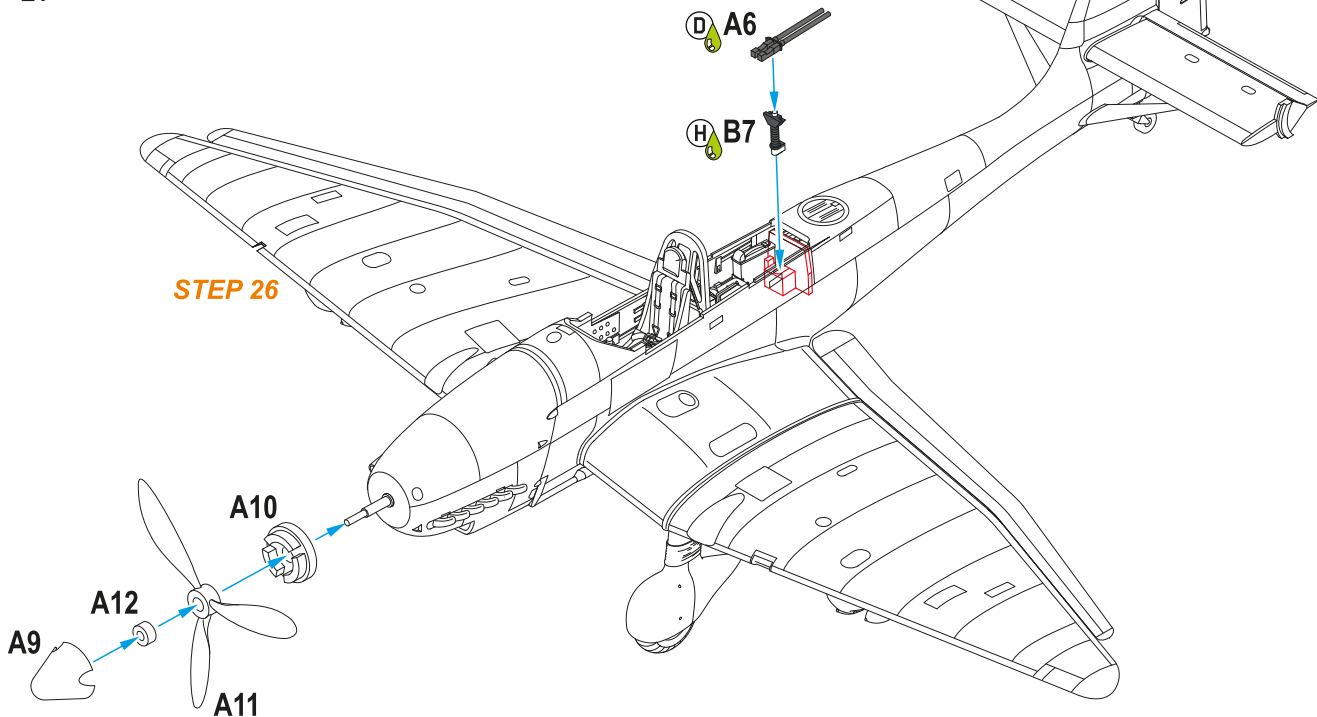

STEP 28

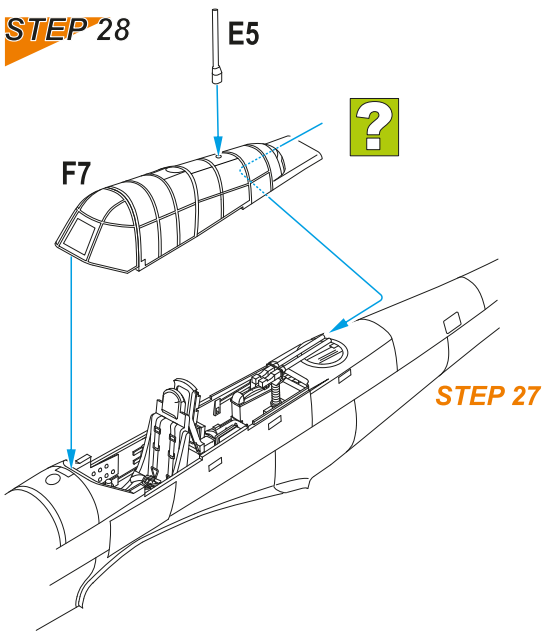

STEP 29

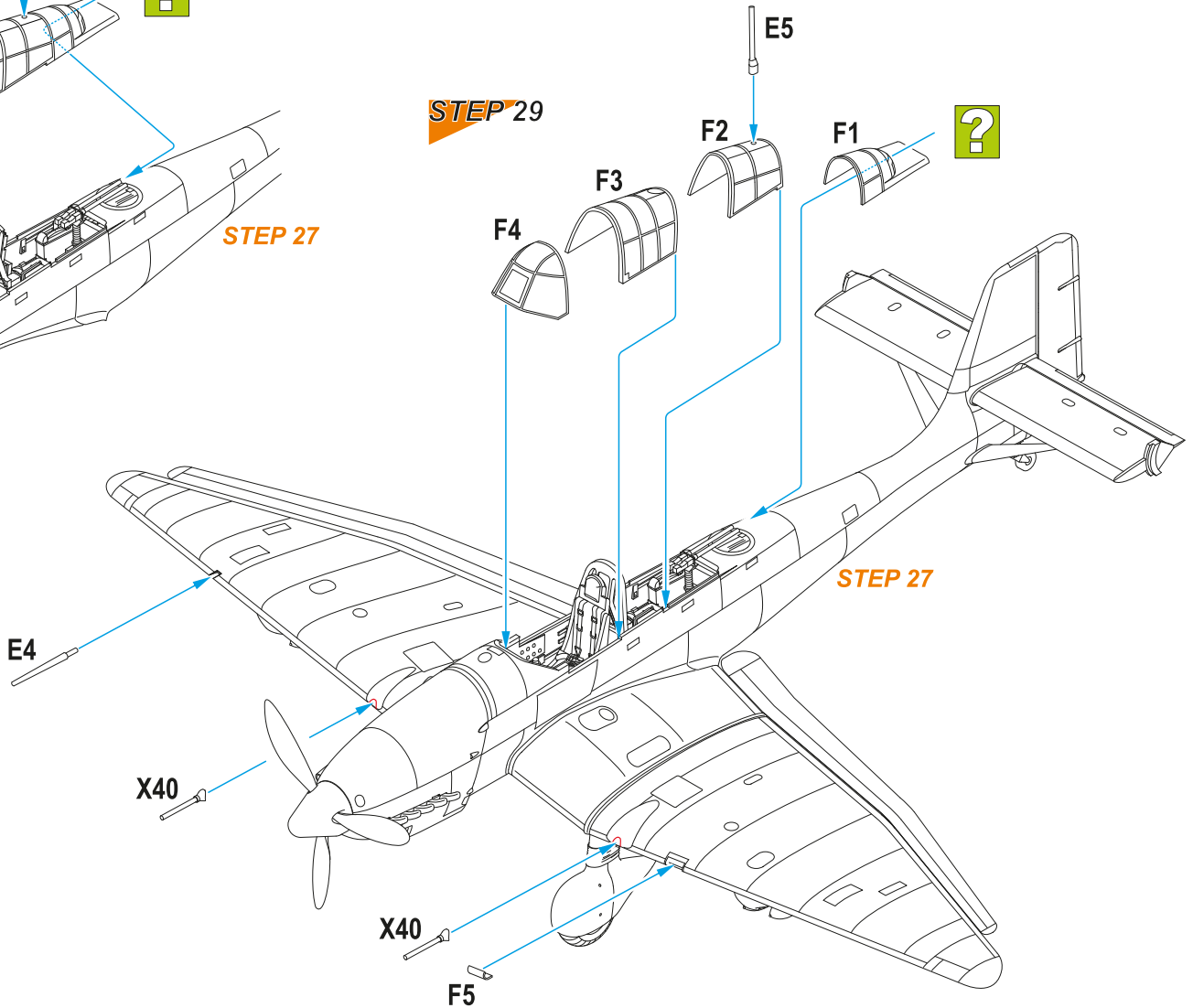

For the Junkers 87D-5 we have prepared the mask M72038 that is sold separately. We also have masks for other Special Hobby kits.

M72038 Junkers Ju 87D/G Stuka 1/72
for Special Hobby / Academy kits

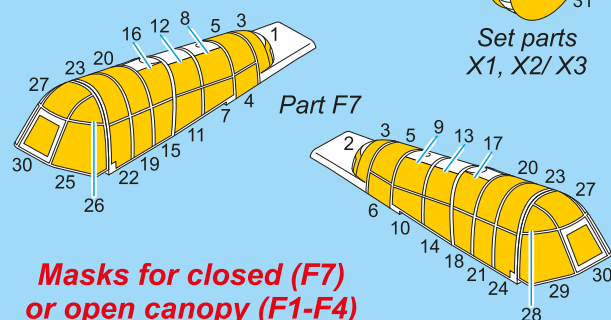
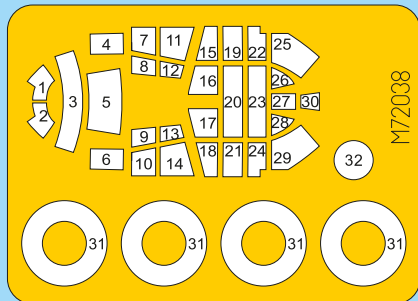

**Masks for closed (F7)
or open canopy (F1-F4)**

- M72001 SMB-2 Super Mystere
- M72002 SAAB 37 Viggen Single S.
- M72003 SAAB 37 Viggen Two Seater
- M72004 Folland Gnat/Ajeet
- M72006 CAC Wirraway
- M72007 AH-1G Cobra
- M72008 B-10/12/model 139 Bomber
- M72009 Messerschmitt Bf 109E-4/7
- M72010 Messerschmitt Bf 109E-1/3
- M72011 SIAI-Marchetti SF-260M/AM/W
- M72012 Focke Wulf Fw 189B
- M72013 Mirage F.1 Single Seater
- M72014 Mirage F.1 Two Seater
- M72015 P-40E/K/Kittyhawk Mk.Ia/Mk.III
- M72016 P-40N/Kittyhawk Mk.IV
- M72017 Fouga C.170 Magister
- M72018 Fouga CM-175 Zephyr
- M72019 Casa C.212/C-41
- M72020 Focke Wulf Fw 189V-6
- M72021 A.W. Meteor NF Mk.14
- M72023 SIAI-Marchetti SF-260EA/D/EU 'Late Bulged Canopy Type'
- M72024 AT-6 Texan/Harvard Mk.II/IIA/IIB
- M72025 Tachikawa Ki-54 Hei / Hickory
- M72026 P-40M Warhawk/Kittyhawk Mk.III
- M72027 A.W. Meteor NF Mk.14
- M72028 Dornier Do.27
- M72029 FH-1 Phantom
- M72030 Heinkel He 162
- M72031 A.W. Meteor NF Mk.11/12/13
- M72032 DH.100 Vampire Mk.I Early & Late MASK
- M72033 DH.100 Vampire Mk.3/5/9 and export variants MASK
- M72034 Gloster Meteor Mk.3/4
- M72035 Bugatti 100 Racer MASK
- M72036 Vautour IIB MASK
- M72037 Tachikawa Ki-54Otsu / Hickory 'Gunner Trainer' MASK



Junkers Ju 87D-5, Grupul 6 Picaj, Rumunské královské leectvo, 1943/44. Nápisy Hai noroc! a Si bucurie! je možné přeložit jako Na zdraví a Radost. Rumunské Stuky operovaly v jižní části východní fronty až do přechodu Rumunska na spojeneckou stranu.

Junkers Ju 87D-5, Grupul 6 Picaj, Royal Romanian Air Force, 1943/44. Hai noroc! translates as 'Cheers!' while Si bucurie! means 'And Joy'. The Romanian Stukas had operated in the southern sector of the Eastern Front until Romania changed sides and joined Allies.

Scheme A

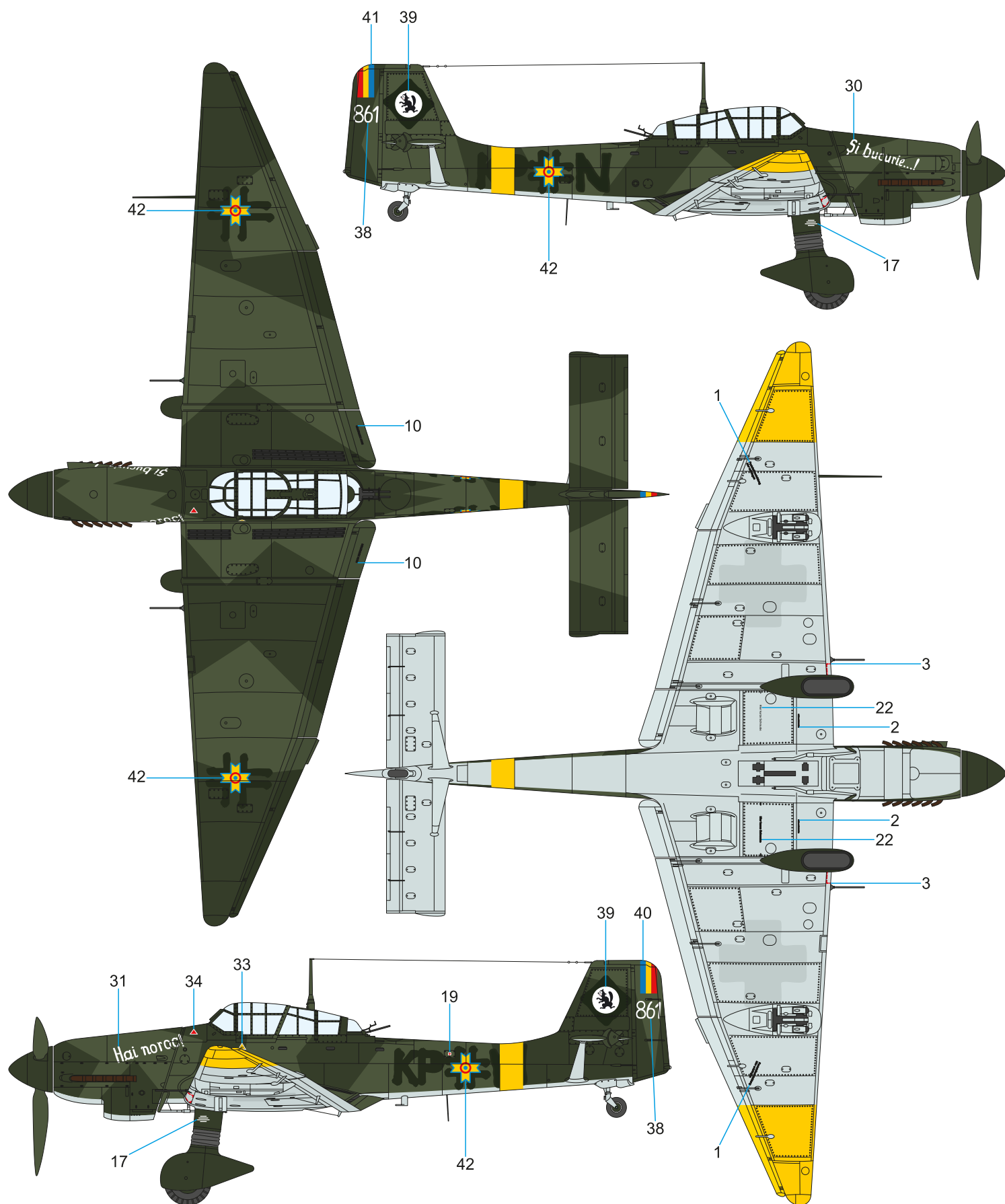

Černo zelená
Black Green
H65 / C18
RLM 70 Schwarzgrün

Tmavá zelená
Dark Green
H64 / C17
RLM 71 Dunkelgrün

Světlá modrá
Light Blue
H67 / C115
RLM 65 Lichtblau

Žlutá
Yellow
H413 / C113
RLM 04 Gelb

Junkers Ju 87D-5, OK-XAB/2, Slovenské vzdušné zbraně, základna Piešťany, jaro 1944. Slovenské Stuky byly vyráběny v licenci v STL (Slovenská Továrň na lietadlá) ve Trenčianských Biskupicích. Většina produkce byla určena Luftwaffe. Slovenské Stuky sloužily k výcviku a měly být použity v SNP. Souhrou nešťastných okolností a chyb velících důstojníků padly do rukou Němců a ti je použili bojově proti slovenským povstalcům.

Junkers Ju 87D-5, OK-XAB/2, Slovak Air Force, based at Piešťany, Spring 1944. The Ju 87 Stuka bombers were licence built at STL (Slovak Aircraft Factory) in Trenčianské Biskupice. Most of the produced airframes went to the Luftwaffe whilst those which did not leave Slovakia flew in the training role and were also to be used in the Slovak National Uprising. Due to the unfortunate circumstances and mistakes of the commanding officers, these Stukas fell into German hands and were combat-used against the Slovak insurgents.

Scheme B

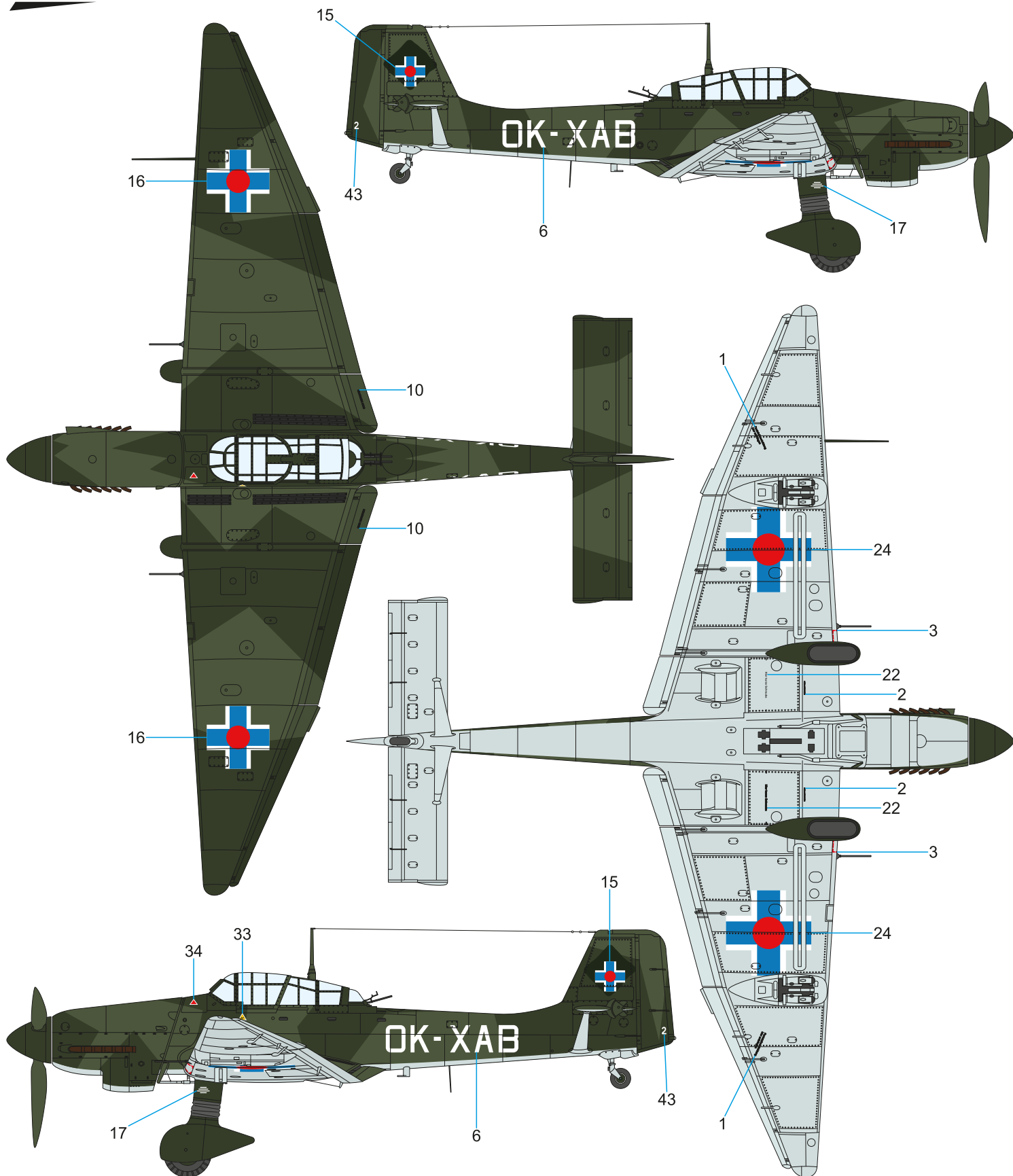

Černo zelená
Black Green
H65 / C18
RLM 70 Schwarzgrün

Tmavá zelená
Dark Green
H64 / C17
RLM 71 Dunkelgrün

Světlá modrá
Light Blue
H67 / C115
RLM 65 Lichtblau

Junkers Ju 87D-5, B.706, pojmenovaný Sírásó II (hrobník II) 102/2, Maďarské letectvo, léto 1944. Na letounu létala osádka pilot szkv. Horváth 'Kabala' Sándor a střelec Hosszú 'Pacsirta' József. Přezdívka pilota nemá nic společného s židovstvím, Kabala je maďarsky maskot, Pacsirta pak skřivan.

Junkers Ju 87D-5, B.706, dubbed Sírásó II (Grave-digger II) 102/2, Royal Hungarian Air Force, Summer 1944. This Stuka was usually flown by pilot szkv. Horváth 'Kabala' Sándor and gunner Hosszú 'Pacsirta' József. The pilot's nickname has no connection with Judaism though, kabala simply means a mascot in Hungarian and Pacsirta is a skylark.

Scheme C

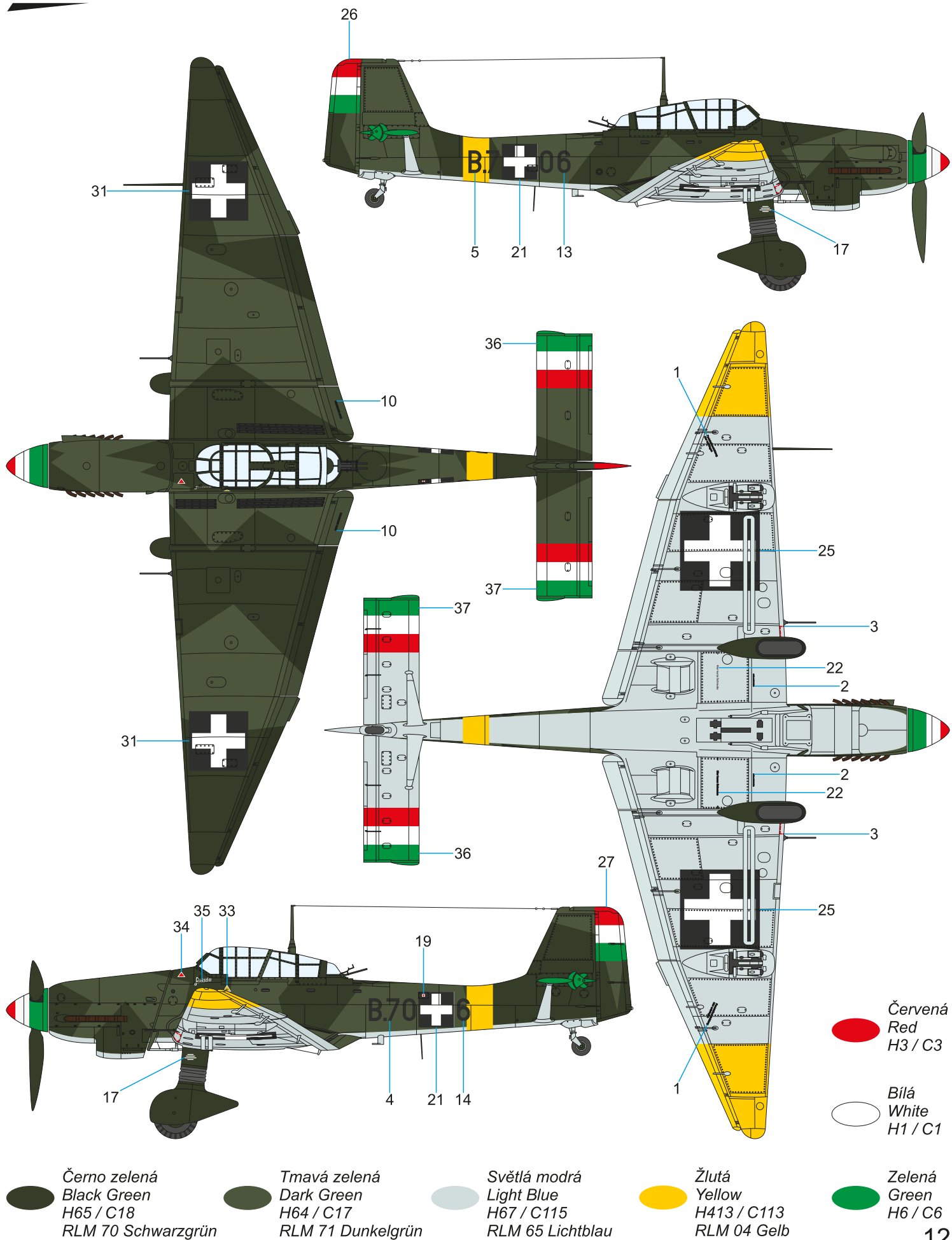

Junkers Ju 87D-5, No.46, 1.Orlyak (skupina), 2. Šturmovi Polk (útočný pluk), Bulharské letectvo, druhá polovina roku 1944. Bulharsko jako německý spojenc používá žluté doplňky. 8. září 1944 přešlo Bulharsko na spojeneckou stranu a 9. září zahájilo vojenské akce proti Německu. Rozkazem 20. září 1944 byly žluté doplňky změněny na bílé. V létě 1944 se účastnil tento letoun se žlutými doplňky protipartizánských akcí nad Makedonií. Ve stejné oblasti 20. září zasáhly letouny 1. Orlyak proti vlakovým transportům SS divize albánských dobrovolníků Skandenberg a způsobily divizi těžké ztráty na lidech i technice.

Junkers Ju 87D-5, No.46, 1.Orlyak (Air Group), 2.Shturmovi Polk (Attack Regiment), Royal Bulgarian Air Force, latter half of 1944. At the time, Bulgaria was on Germany's side and so its aircraft wore yellow ID markings. On 8 September 1944, Bulgaria joined the Allies and a day later, military operations against Germany were launched. By the order of 20 September 1944, the yellow IDs were to be changed to white ones. In the summer of 1944, the aircraft depicted here wearing yellow markings took part in the anti-insurgent operations over Macedonia. And on 20 September, the 1. Orlyak aircraft attacked in the same area the transports of the Albanian SS volunteer division Skandenberg, causing the division heavy losses both on troops and equipment.

Scheme D

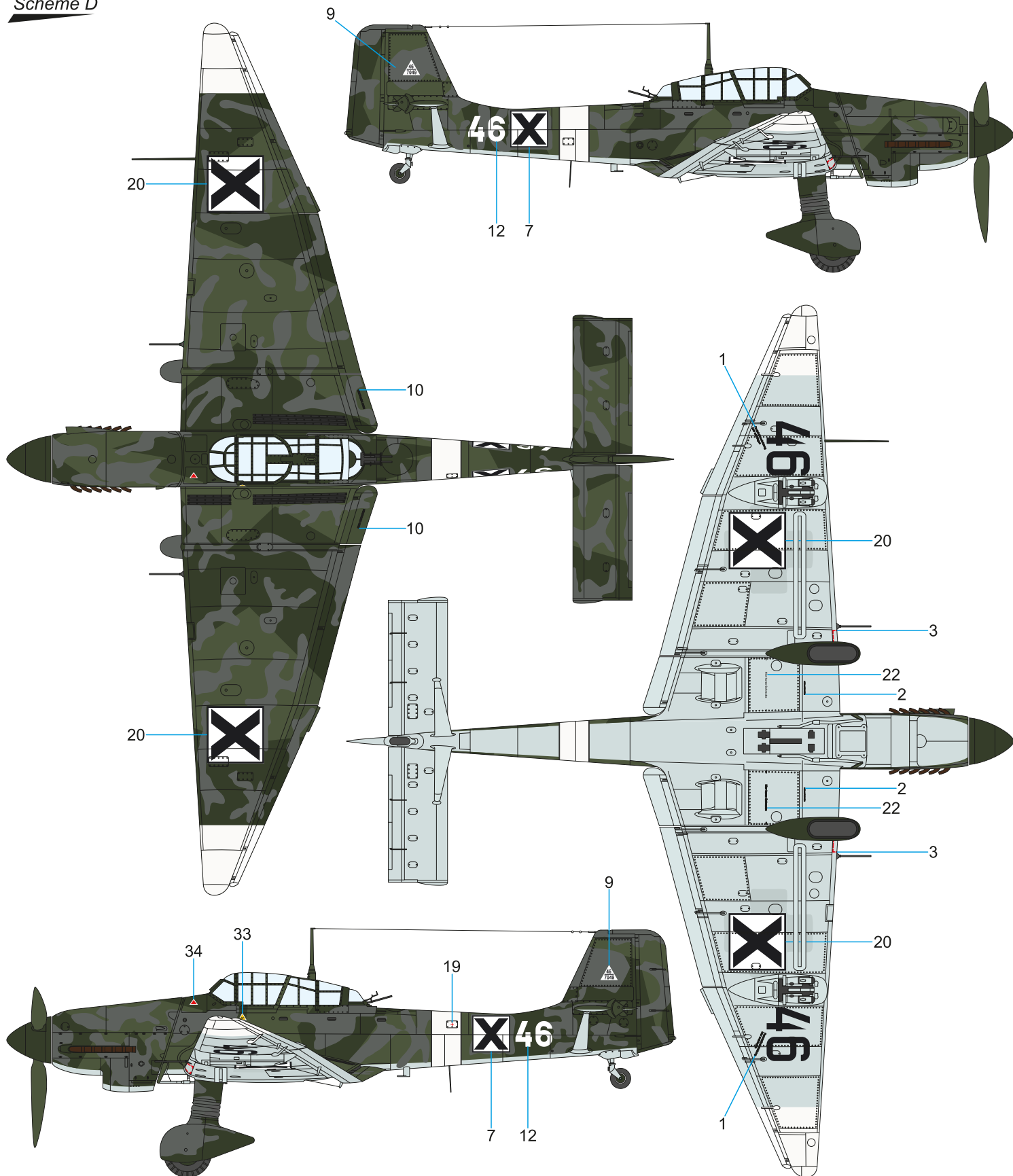

Černo zelená
Black Green
H65 / C18
RLM 70 Schwarzgrün

Tmavá zelená
Dark Green
H64 / C17
RLM 71 Dunkelgrün

Světlá modrá
Light Blue
H67 / C115
RLM 65 Lichtblau

Šedá
Grey
H69 / C37
RLM 75 Grauviolett

Bílá
White
H11 / C62

1/72
SH72341



M72030 Heinkel He 162 MASK

Special
MASK

Heinkel He 162 Spatz 'German WWII Jet Fighter'

Heinkel He 162A CMK RESIN SETS for Special Hobby kits



7443

Heinkel He 162A
Engine
(BMW 003 Jet Engine)



Q72361

Heinkel He 162A
Ejection Seat

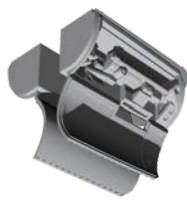

7444

Heinkel He 162A
Gun bays
(BMW 003 Jet Engine)



Q72362

Heinkel He 162A
Wheels



F72365

Three Pilot Figures, Each
in Different Gear:
Great Coat, Flying Suit, Breeches



F72372

German He 162A
Mechanics
(2 figures)



1/72 SH72138

Messerschmitt Me 209V-1



1/72 SH72221

Messerschmitt Me 209V-4

Messerschmitt Me 209 CMK RESIN SET for Special Hobby kits

Q72304

Messerschmitt Me 209
Mainwheels





1/72
SH72430

Focke Wulf Fw 189B-0/B-1

'Luftwaffe Trainer'

M72012 Focke Wulf Fw 189B MASK

special
MASK

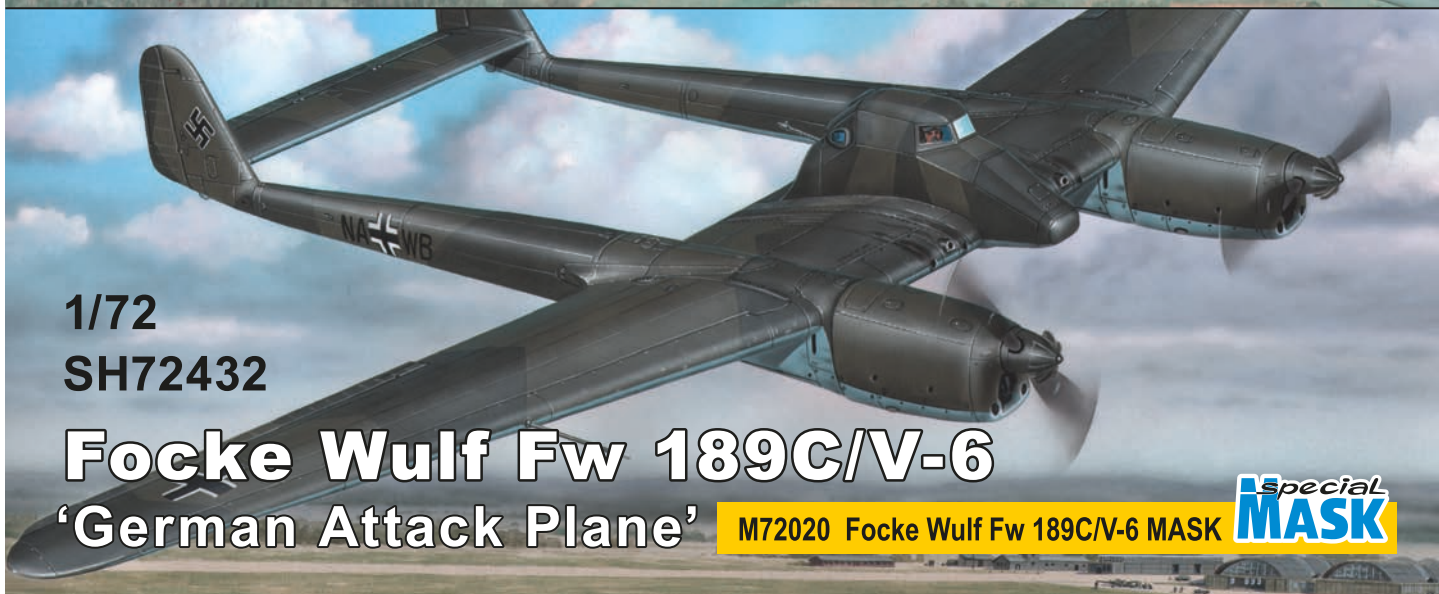

1/72
SH72432

Focke Wulf Fw 189C/V-6

'German Attack Plane'

M72020 Focke Wulf Fw 189C/V-6 MASK

special
MASK

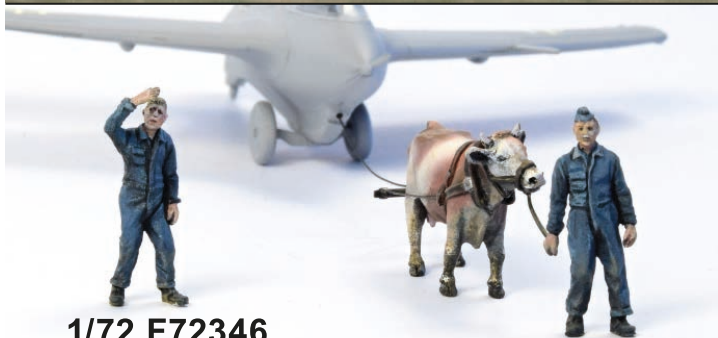

1/72 F72346
Ox towing a Me 163B w/2 Luftwaffe Around Crew



1/72 SH72229 WWII German Pilots At Rest

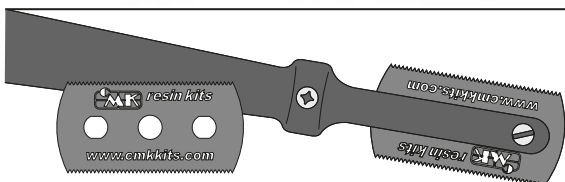

The Razor Saw with Handle (cat. n. H1010) is a great tool for cutting both plastic and resin. CMK also offers a wide variety of coarse/medium/fine saws.

- H1000** Ultra smooth and extra smooth saw (2 sides – 70 teeth / 42 teeth) 1 pc
- H1001** Ultra smooth saw (both sides – 70 teeth / 70 teeth) 1 pc
- H1002** Very smooth saw (both sides – 42 teeth / 42 teeth) 1 pc

- H1003** Smooth saw (both sides – 31 teeth / 31 teeth) 1 pc
- H1004** Ultra smooth and extra smooth saw (2 sides – 70 teeth / 42 teeth) 5 pcs
- H1005** Ultra smooth saw (both sides – 70 teeth / 70 teeth) 5 pcs

- H1006** Very smooth saw (both sides – 42 teeth / 42 teeth) 5 pcs
- H1007** Smooth saw (both sides – 31 teeth / 31 teeth) 5 pcs
- H1010** Razor Saw with Handle

1/72
SH72459

Messerschmitt
Bf 109E-1
'J/88 Legion Condor'

New range of outstanding
Bf 109E kits in 1/72 scale



**Special
MASK**

M7209 Messerschmitt
Bf 109E-4/7 Mask

M72010 Messerschmitt
Bf 109E-1/3 Mask

1/72
SH72443

Messerschmitt
Bf 109E-3



1/72
SH72454

Messerschmitt
Bf 109E-1 'Lightly-Armed'

Messerschmitt Bf 109E CMK RESIN SETS for Special Hobby kits



7455
Bf 109E
Engine



7457
Bf 109E-3/4/7
Wing Guns



7458
Bf 109E
FuG VII Radio
Equipment



7460
Bf 109E-1/5
Wing
Machine Guns



7461
ESK 2000 B
German WWII
Gun Camera

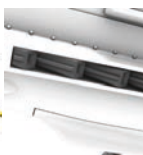

Q72390
Bf 109E
Exhausts



Q72384
Bf 109E
Wheels

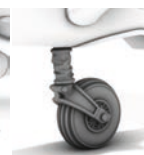

Q72391
Bf 109E
Tailwheel with
Strengthened Leg



Q72389
Bf 109E
Propeller
Spinner



F72369
Bf 109E Ace
A. Galland and
Mechanic