

**eduard**

**LIMITED**



# THE ZIPPER

**F-104C Starfighter in Vietnam war**

**INSTRUCTION SHEET**

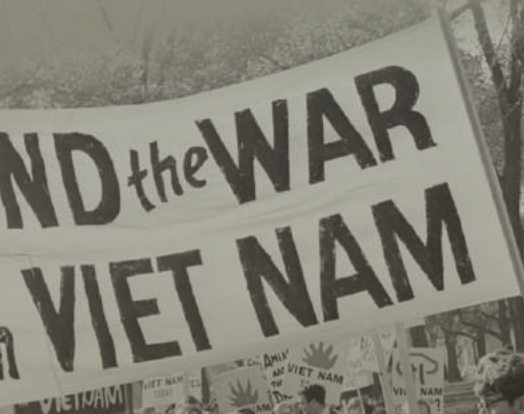

**1/48**

**11169-NAV1**

ATTENTION



UPOZORNĚNÍ



ACHTUNG



ATTENTION



注意



Carefully read instruction sheet before assembling. When you use glue or paint, do not use near open flame and use in well ventilated room. Keep out of reach of small children. Children must not be allowed to suck any part, or pull vinyl bag over the head.



Před započatím stavby si pečlivě prostudujte stavební návod. Při používání barev a lepidla pracujte v dobře větrané místnosti. Lepidla ani barvy nepoužívejte v blízkosti otevřeného ohně. Model není určen malým dětem, mohlo by dojít k požití drobných dílů.

INSTRUCTION SIGNS \* INSTR. SYMBOLS \* INSTRUKTION SINNBILDEN \* SYMBOLES \* 記号の説明

OPTIONAL  
VOLBABEND  
OHNOUTSAND  
BROUSITOPEN HOLE  
VYVRTAT OTVORSYMETRICAL ASSEMBLY  
SYMETRICKÁ MONTÁŽREMOVE  
ODŘÍZNOUTREVERSE SIDE  
OTOČITAPPLY EDUARD MASK  
AND PAINT  
POUŽIT EDUARD MASK  
NABARVITPLEASE CHECK THE LATEST VERSION OF THE INSTRUCTIONS ON [www.eduard.com](http://www.eduard.com)

PARTS



DÍLY



TEILE



PIÈCES



部品

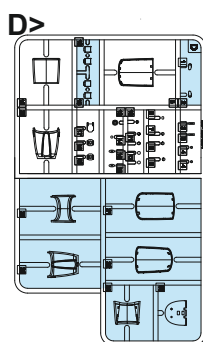
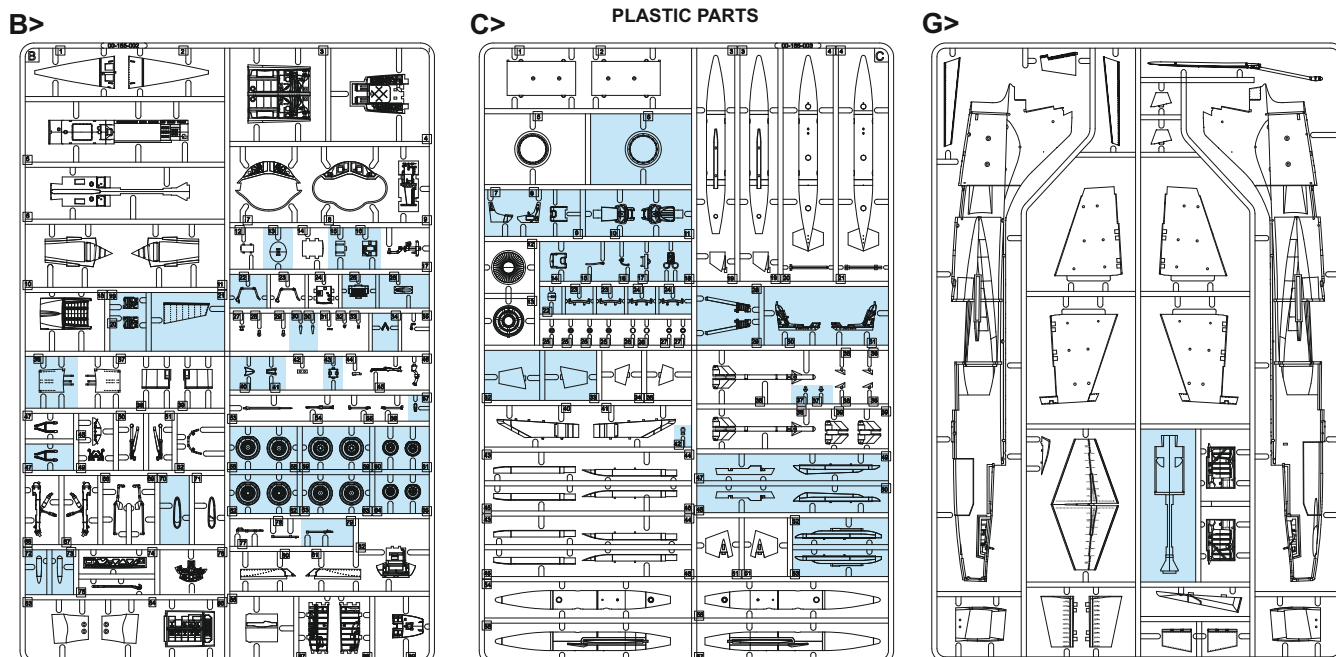

PE - PHOTO ETCHED DETAIL PARTS

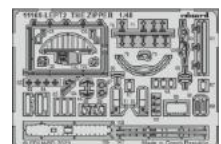
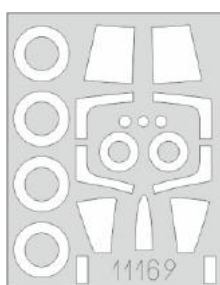
eduard  
MASK

RP - RESIN PARTS

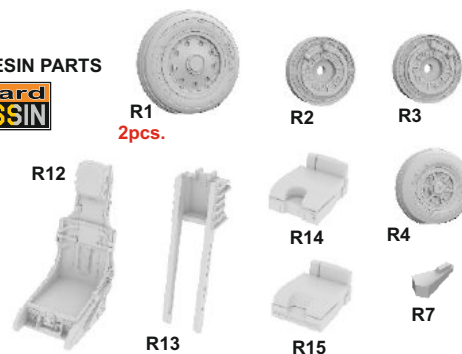
eduard  
BRASSIN

-Parts not for use. -Teile werden nicht verwendet. -Pièces à ne pas utiliser. -Tyto díly nepoužívejte při stavbě. - 使用しない部品

COLOURS



BARVY



FARBEN



PEINTURE



色

GSI Creos (GUNZE)		
AQUEOUS	Mr.COLOR	
<a href="#">H1</a>	<a href="#">C1</a>	WHITE
<a href="#">H8</a>	<a href="#">C8</a>	SILVER
<a href="#">H11</a>	<a href="#">C62</a>	FLAT WHITE
<a href="#">H12</a>	<a href="#">C33</a>	FLAT BLACK
<a href="#">H25</a>	<a href="#">C34</a>	SKY BLUE
<a href="#">H27</a>	<a href="#">C44</a>	TAN
<a href="#">H57</a>	<a href="#">C73</a>	AIRCRAFT GRAY
<a href="#">H77</a>	<a href="#">C137</a>	TIRE BLACK
<a href="#">H80</a>	<a href="#">C54</a>	KHAKI GREEN
<a href="#">H90</a>	<a href="#">C47</a>	CLEAR RED
<a href="#">H94</a>	<a href="#">C138</a>	CLEAR GREEN
<a href="#">H303</a>	<a href="#">C303</a>	GREEN
<a href="#">H304</a>	<a href="#">C304</a>	OLIVE DRAB

GSI Creos (GUNZE)		
AQUEOUS	Mr.COLOR	
<a href="#">H309</a>	<a href="#">C309</a>	GREEN
<a href="#">H310</a>	<a href="#">C310</a>	BROWN
<a href="#">H311</a>	<a href="#">C311</a>	GRAY
<a href="#">H316</a>	<a href="#">C316</a>	WHITE
<a href="#">H317</a>	<a href="#">C317</a>	GRAY
<a href="#">H327</a>	<a href="#">C327</a>	RED
<a href="#">H328</a>	<a href="#">C328</a>	BLUE
Mr.METAL COLOR		
<a href="#">MC213</a>		STEEL
<a href="#">MC214</a>		DARK IRON
Mr.COLOR SUPER METALLIC		
<a href="#">SM201</a>		SUPER FINE SILVER
<a href="#">SM204</a>		SUPER STAINLESS 2



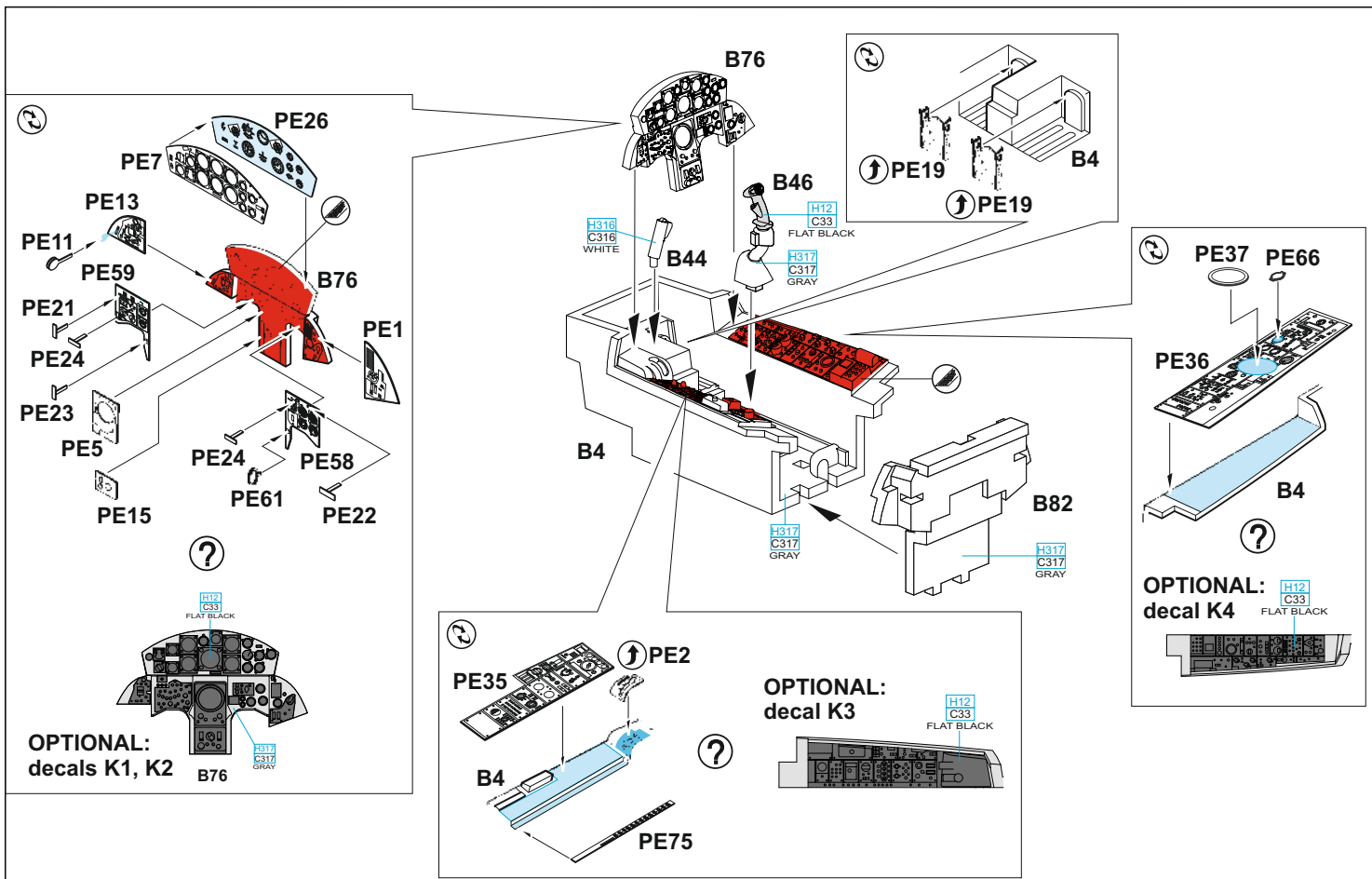

**eduard**  
**BRASSIN**

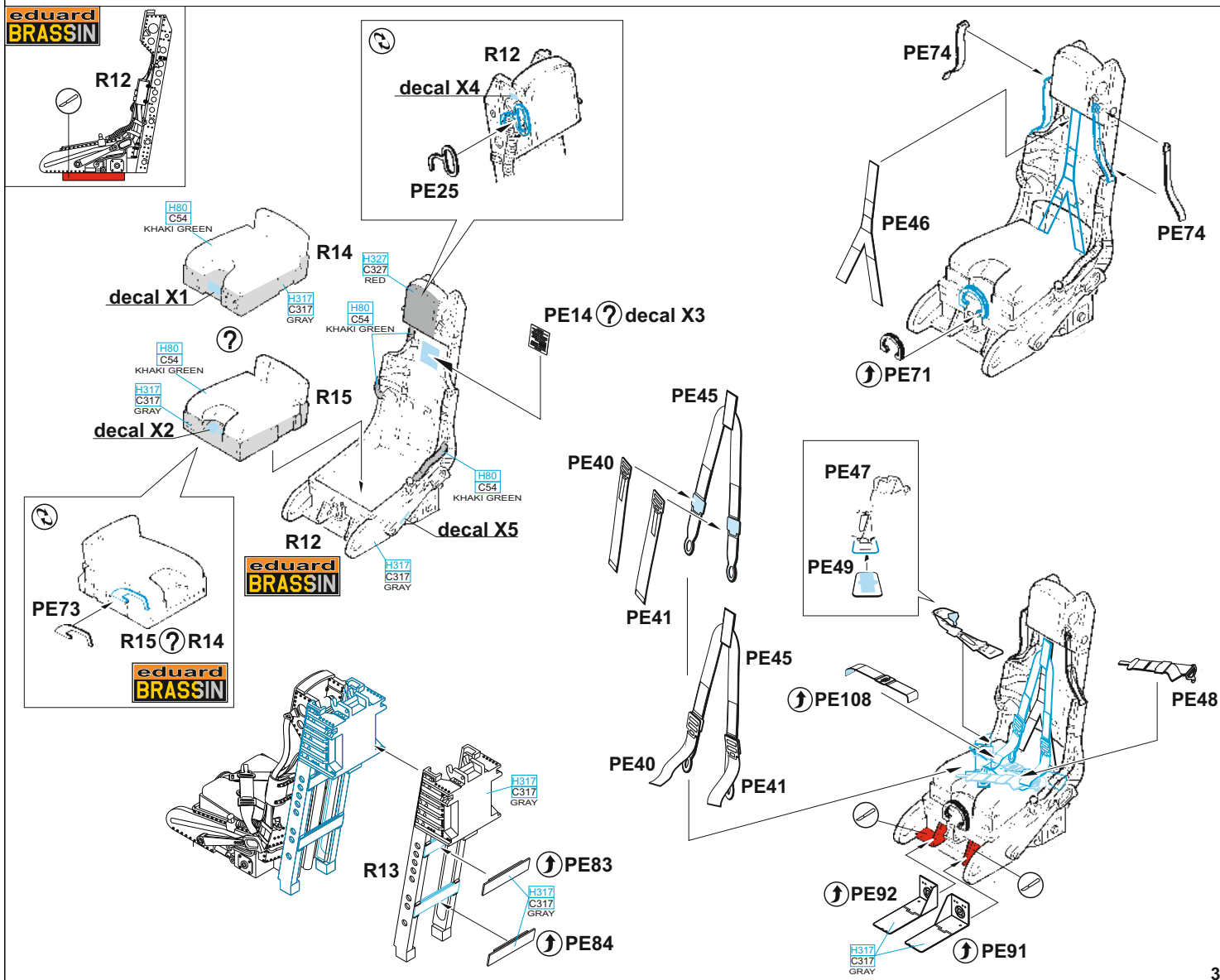

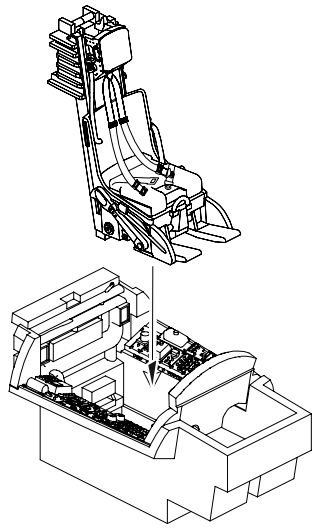

**B**

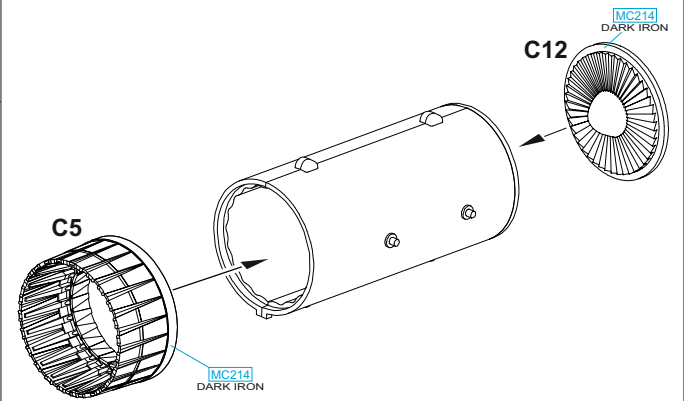
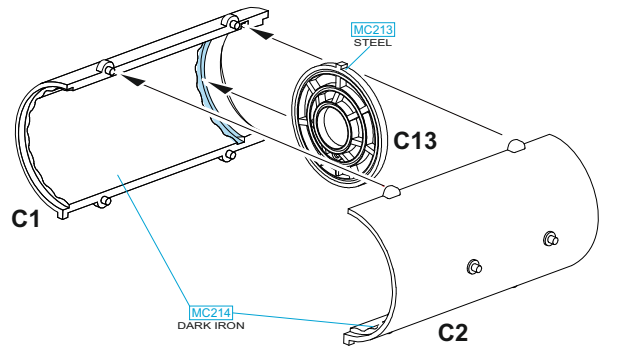

**C**

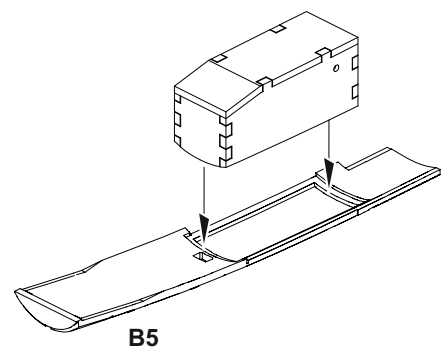
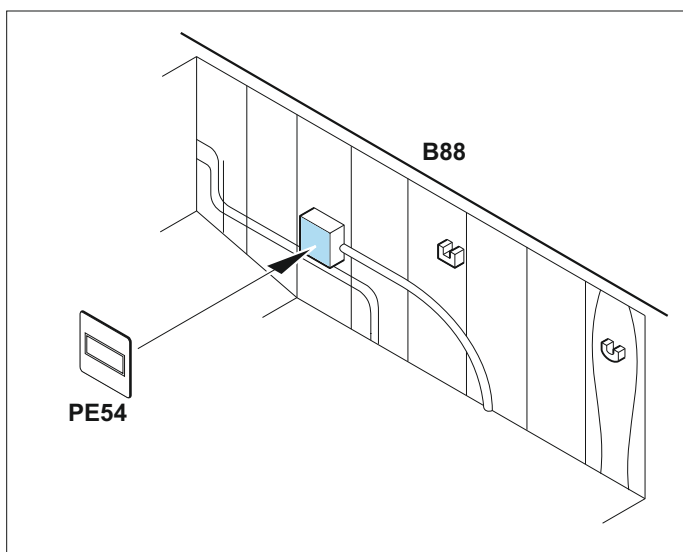
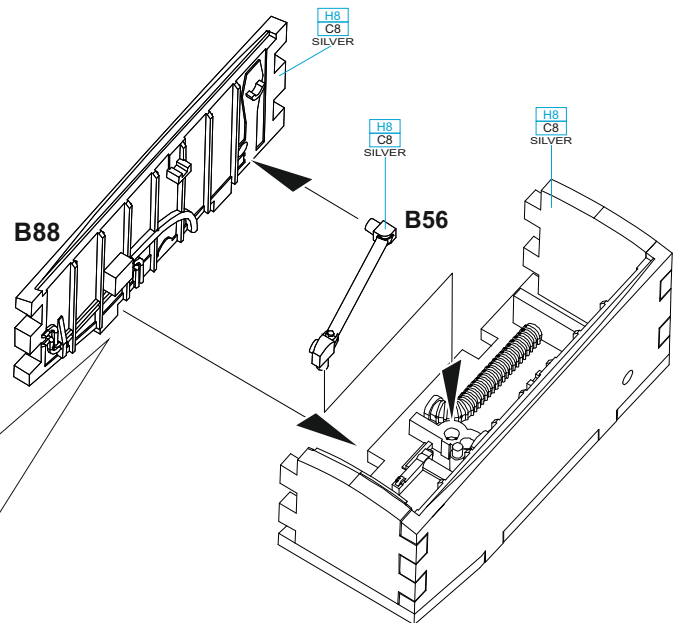
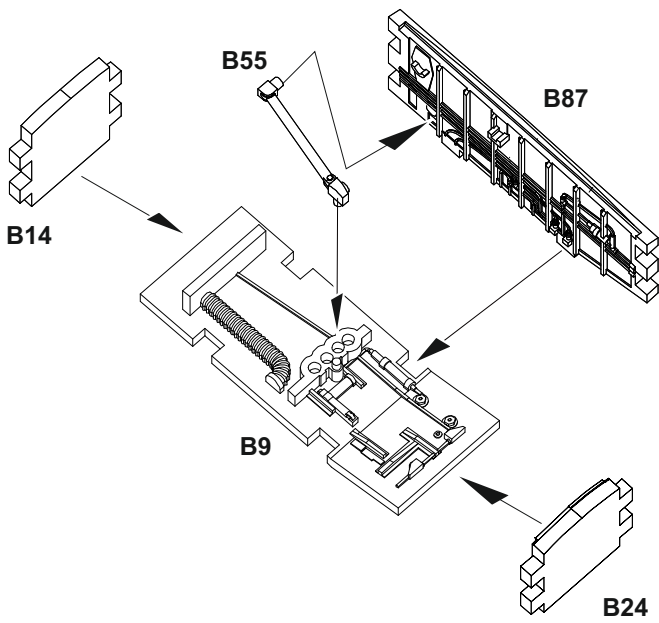



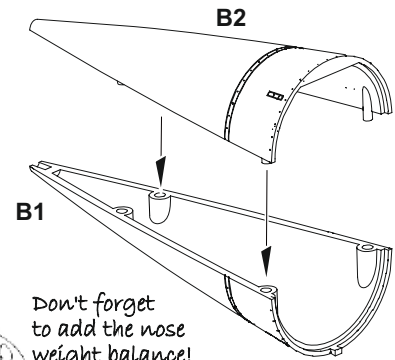
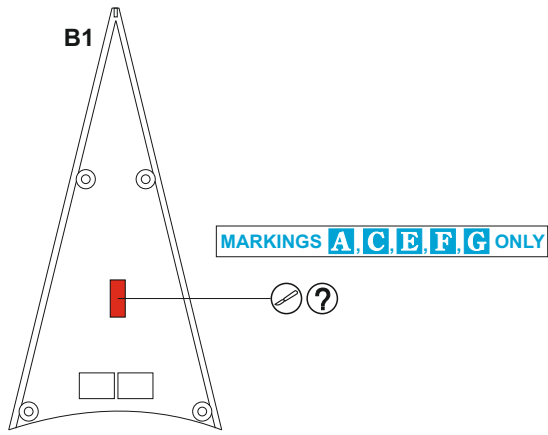

Don't forget  
to add the nose  
weight balance!

**D**

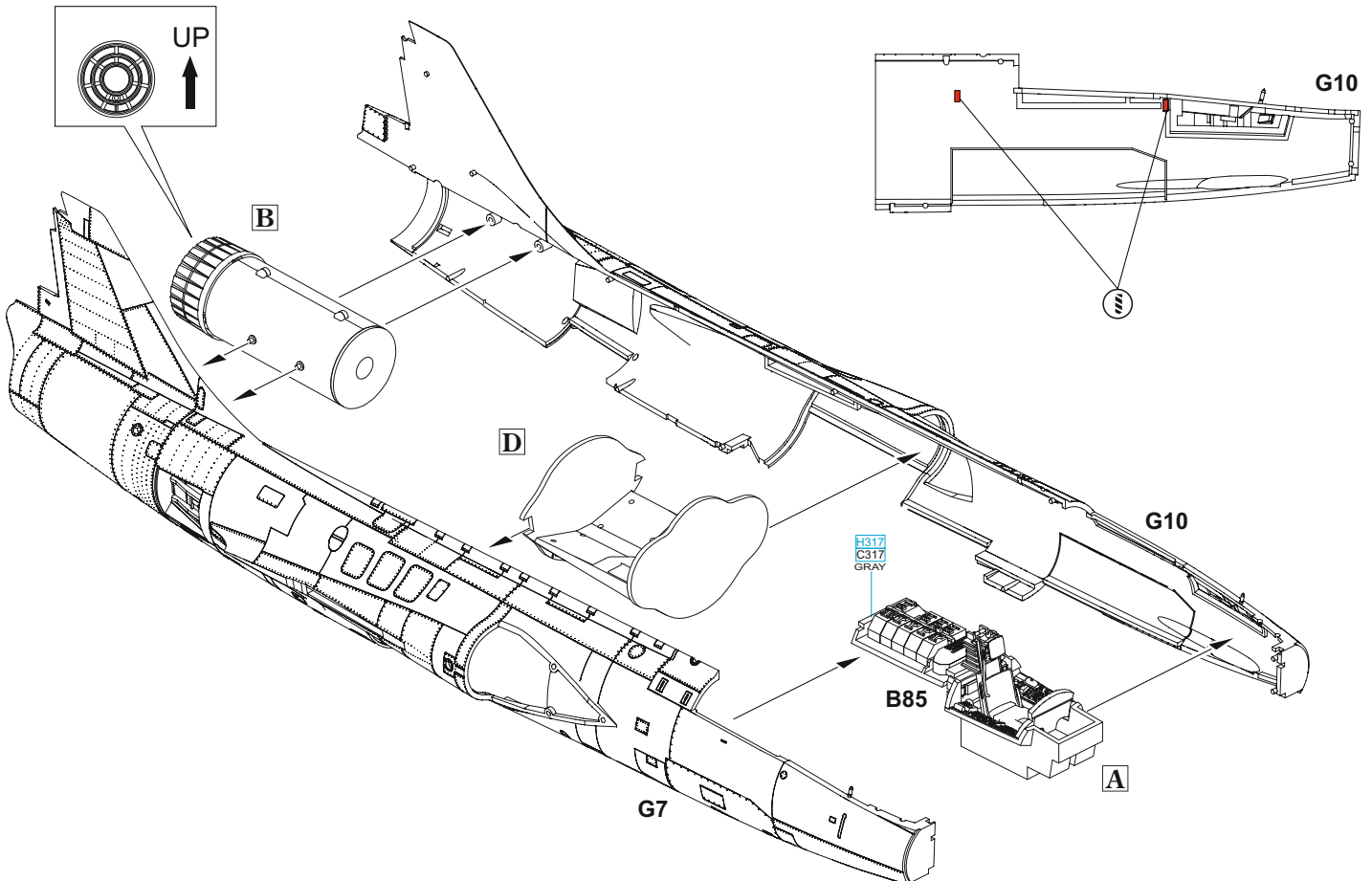
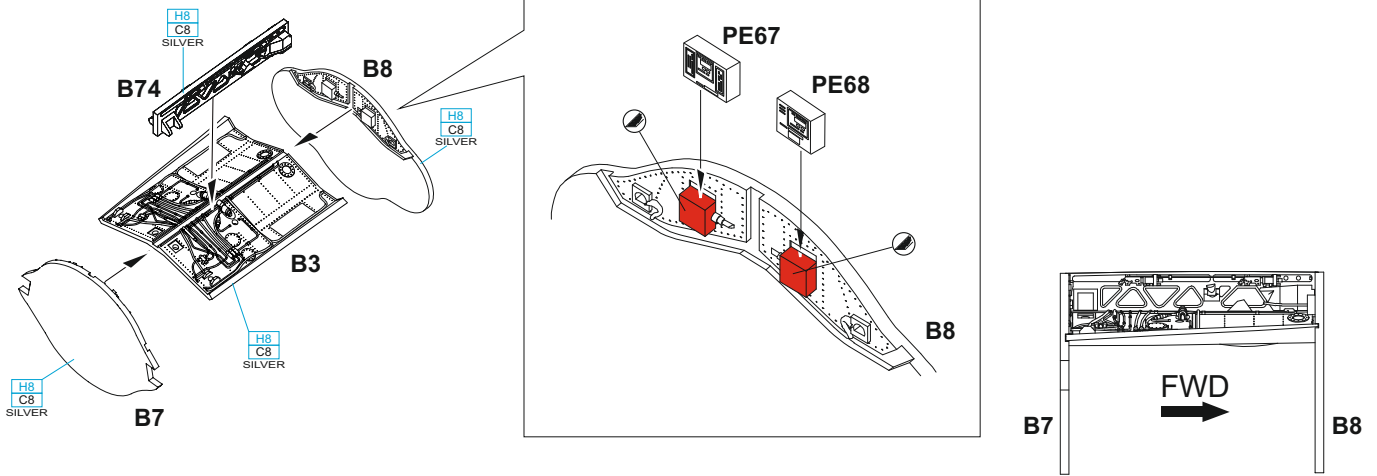

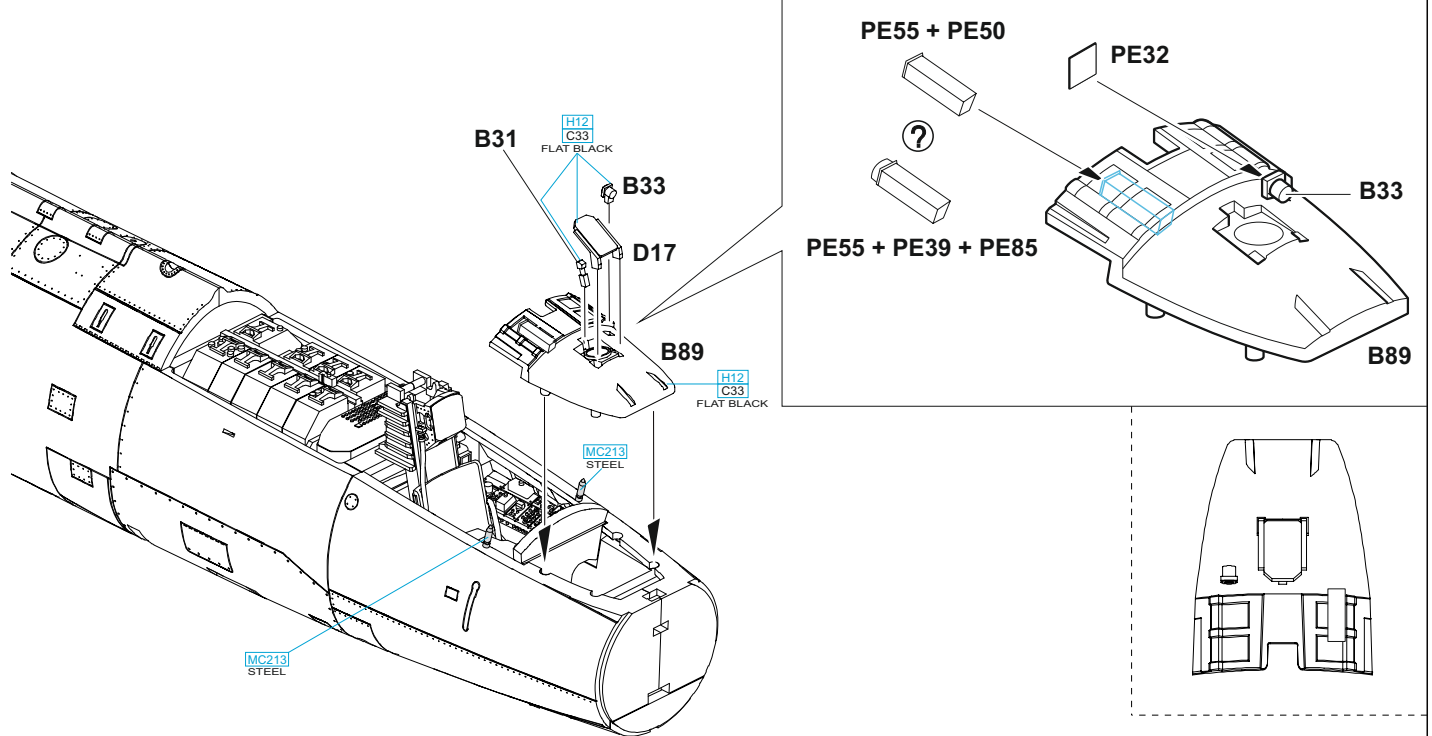
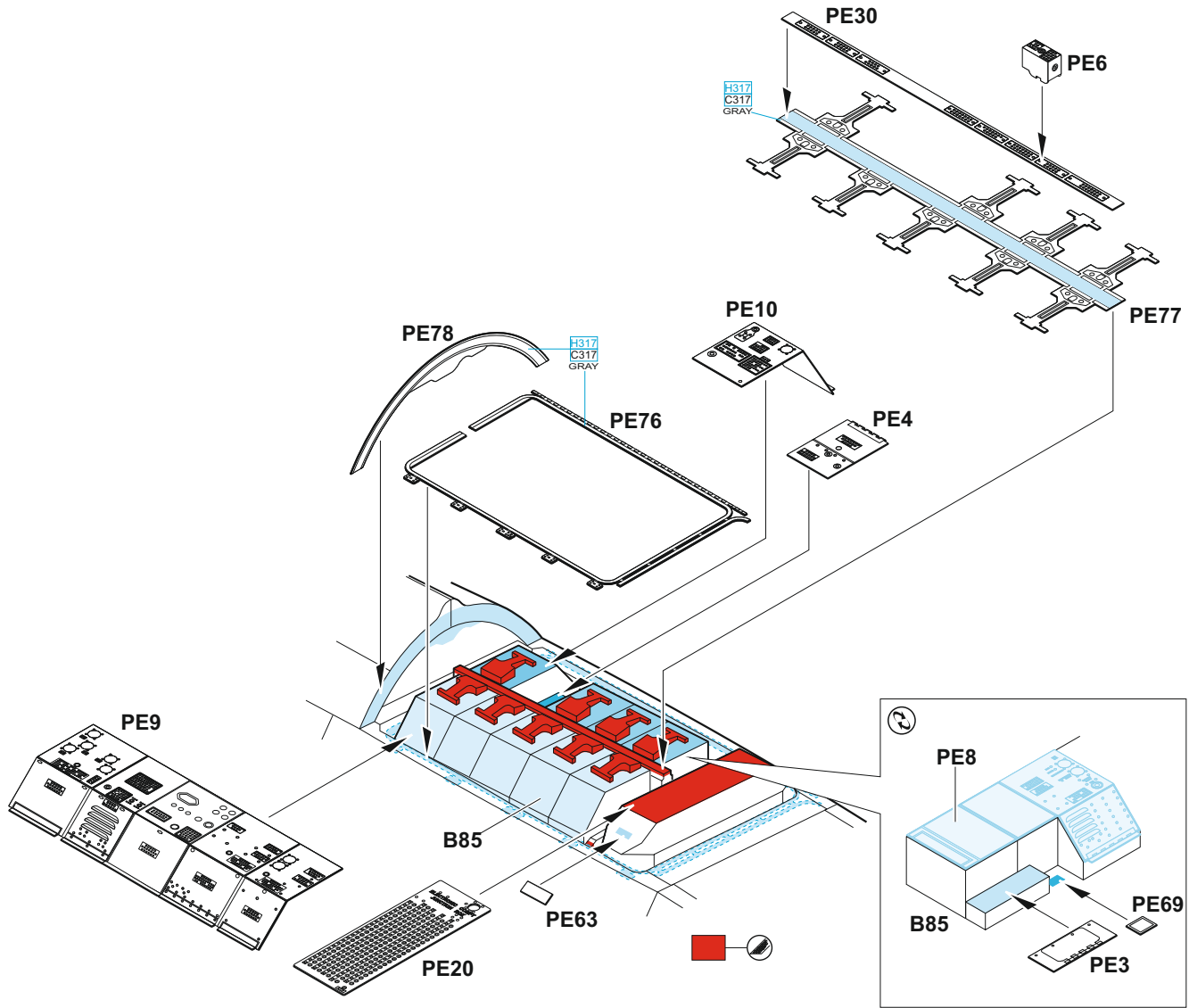

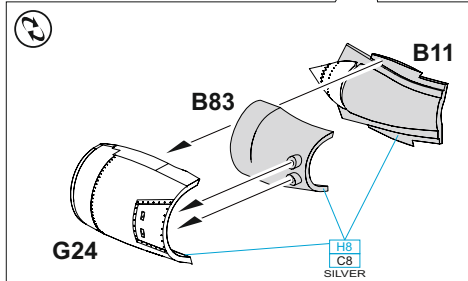
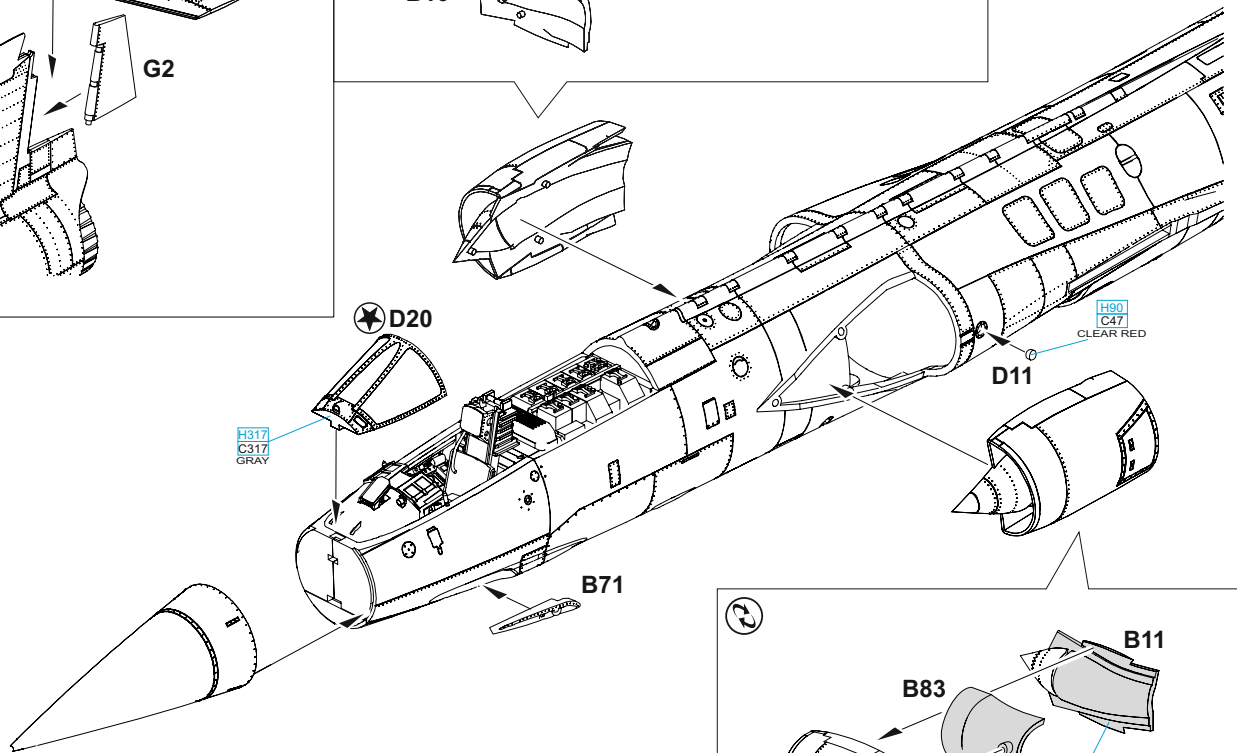
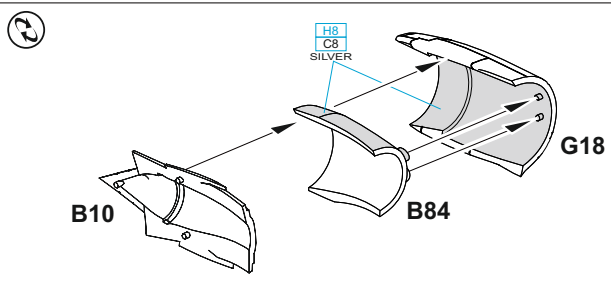
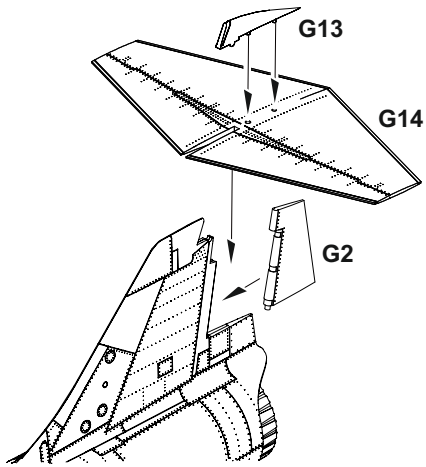
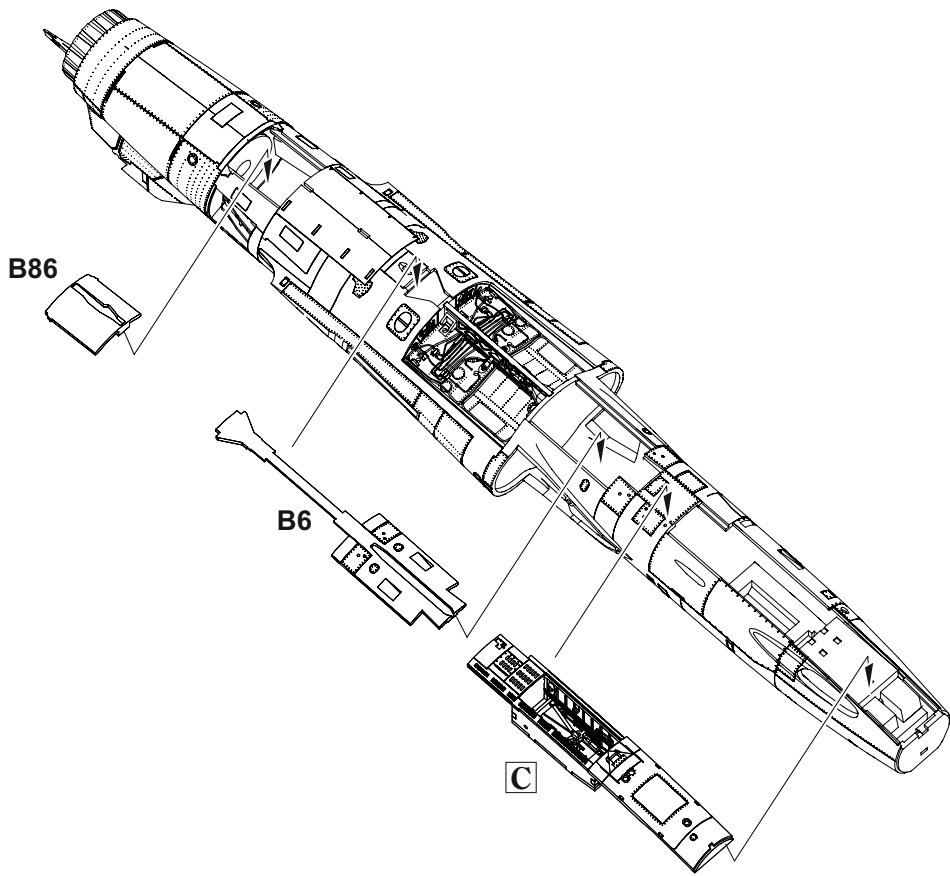



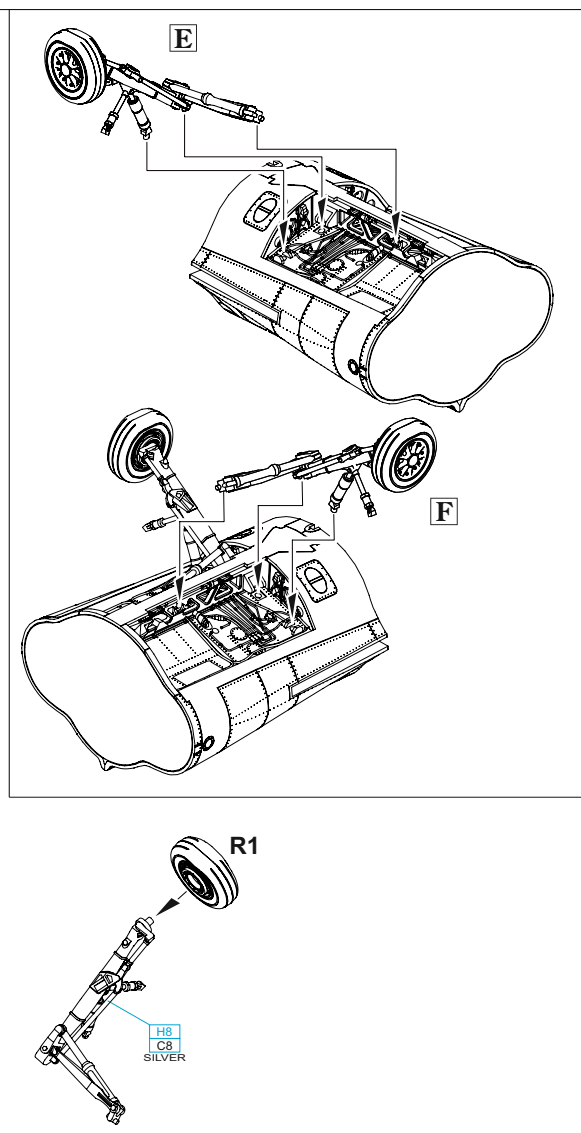
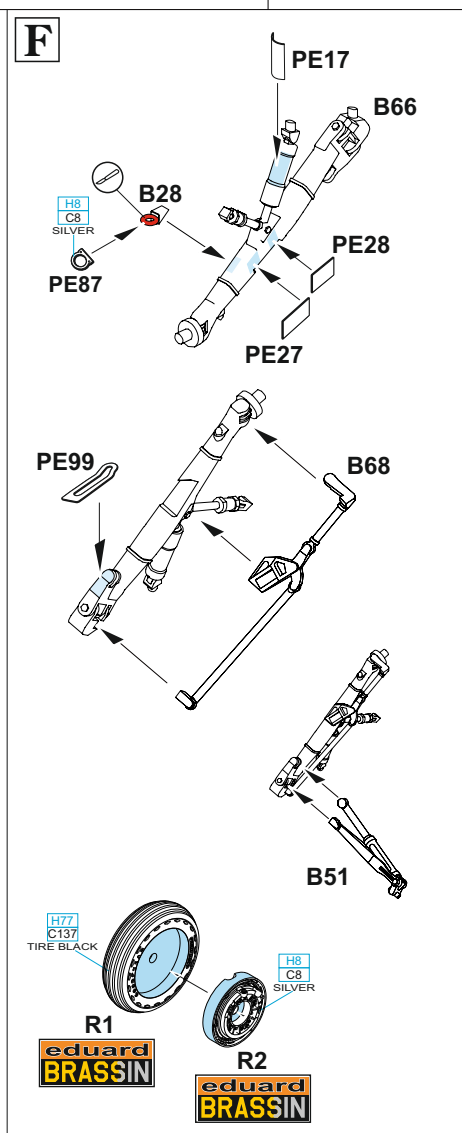
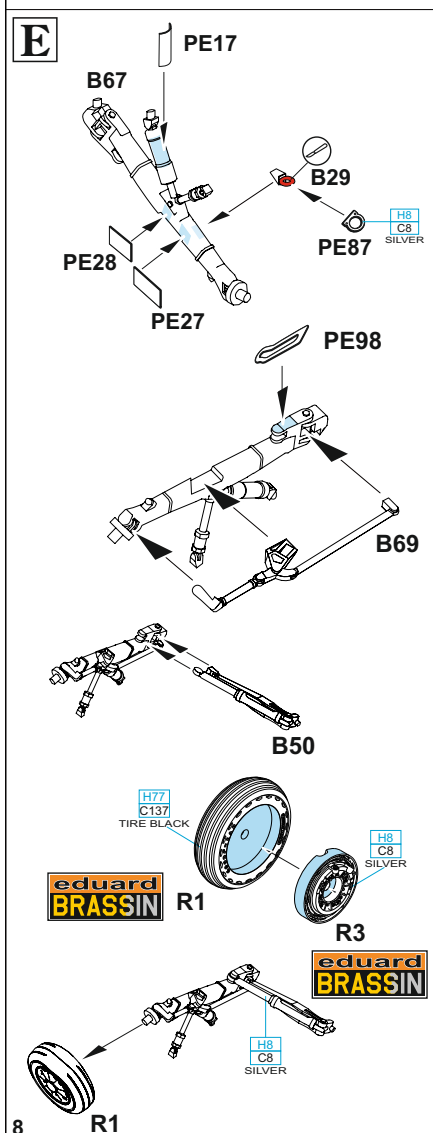
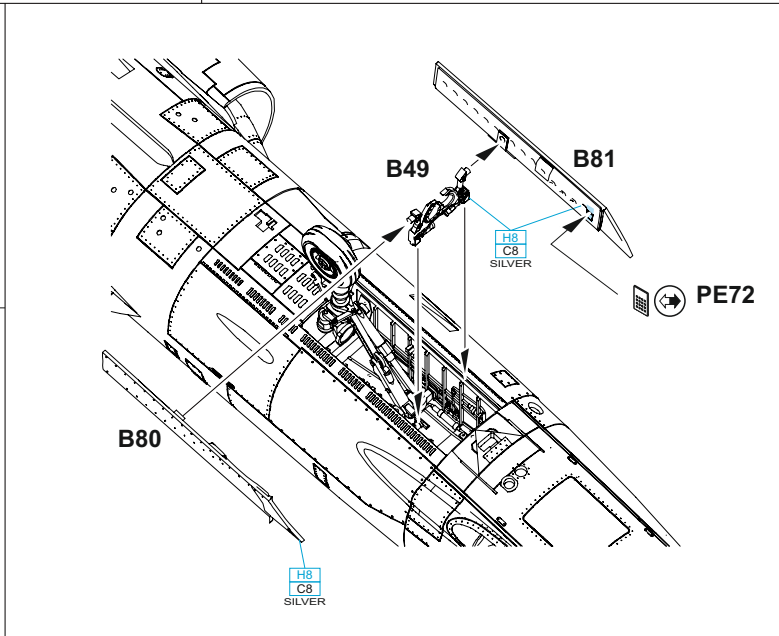
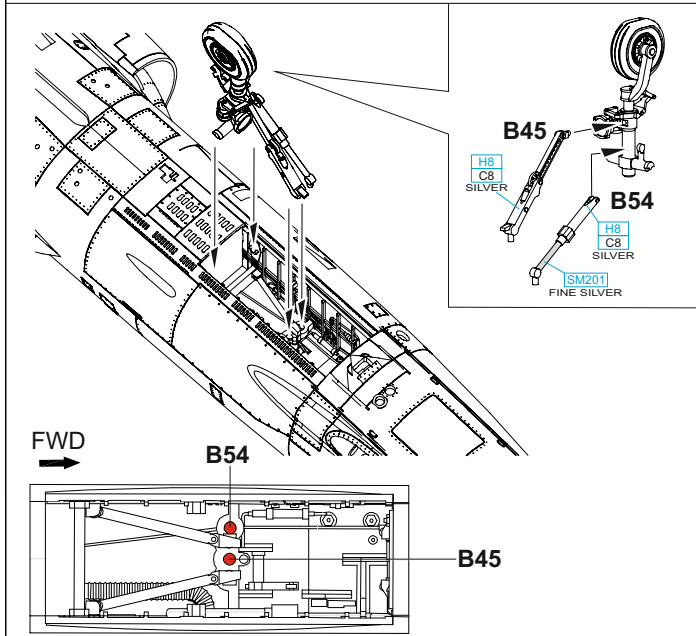
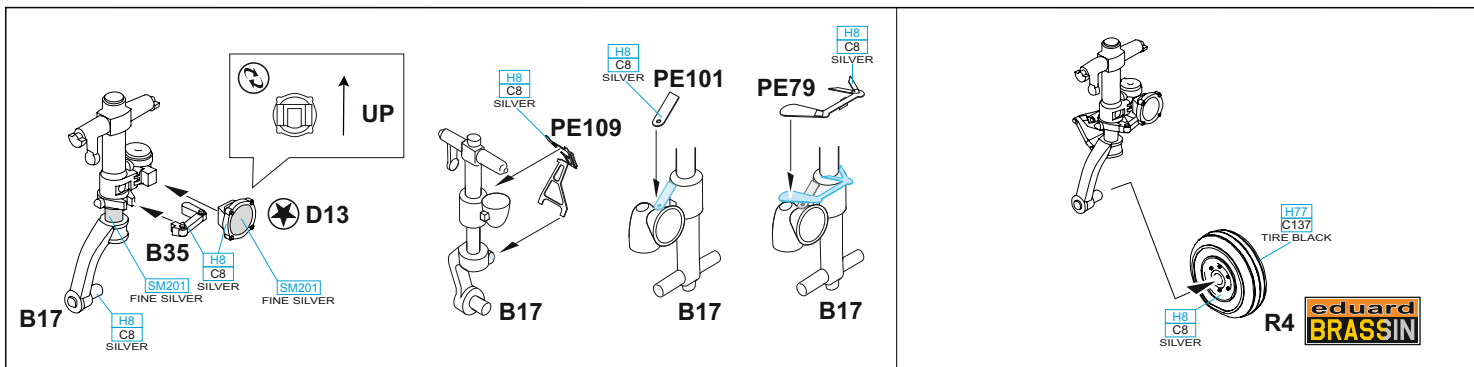

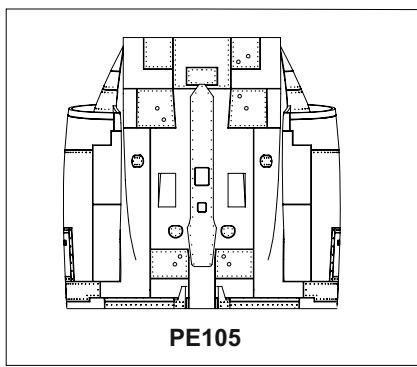
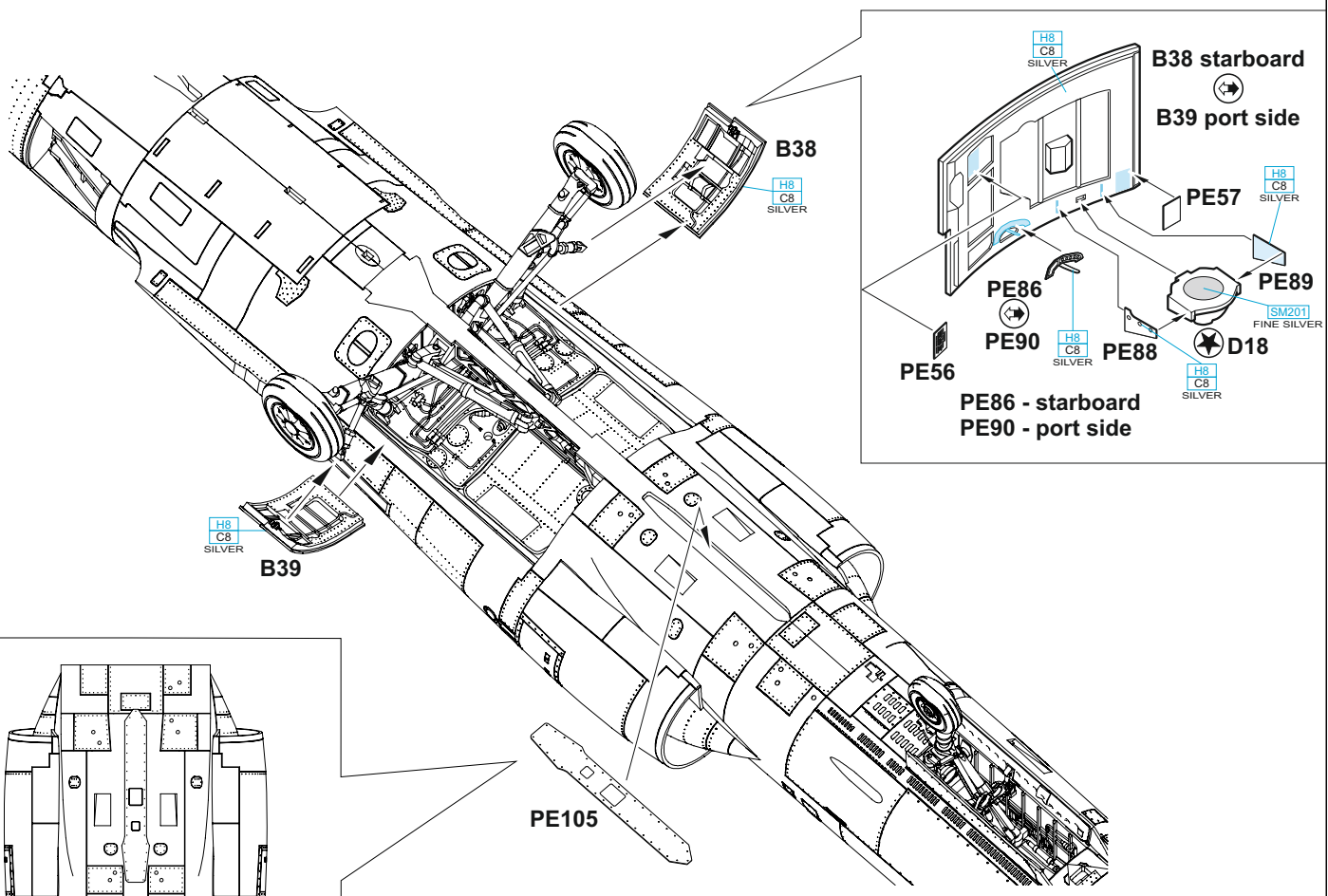

**PE105**

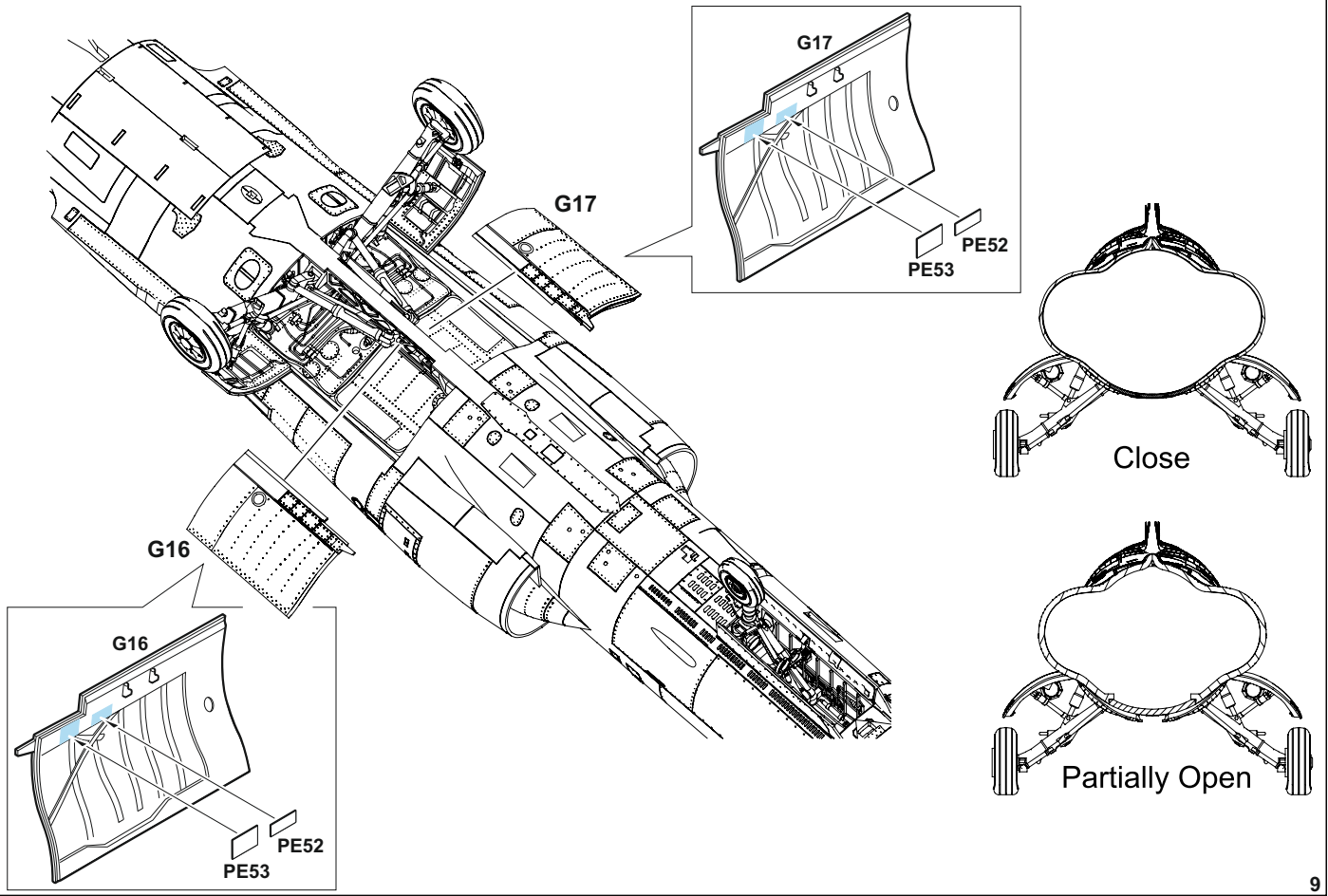

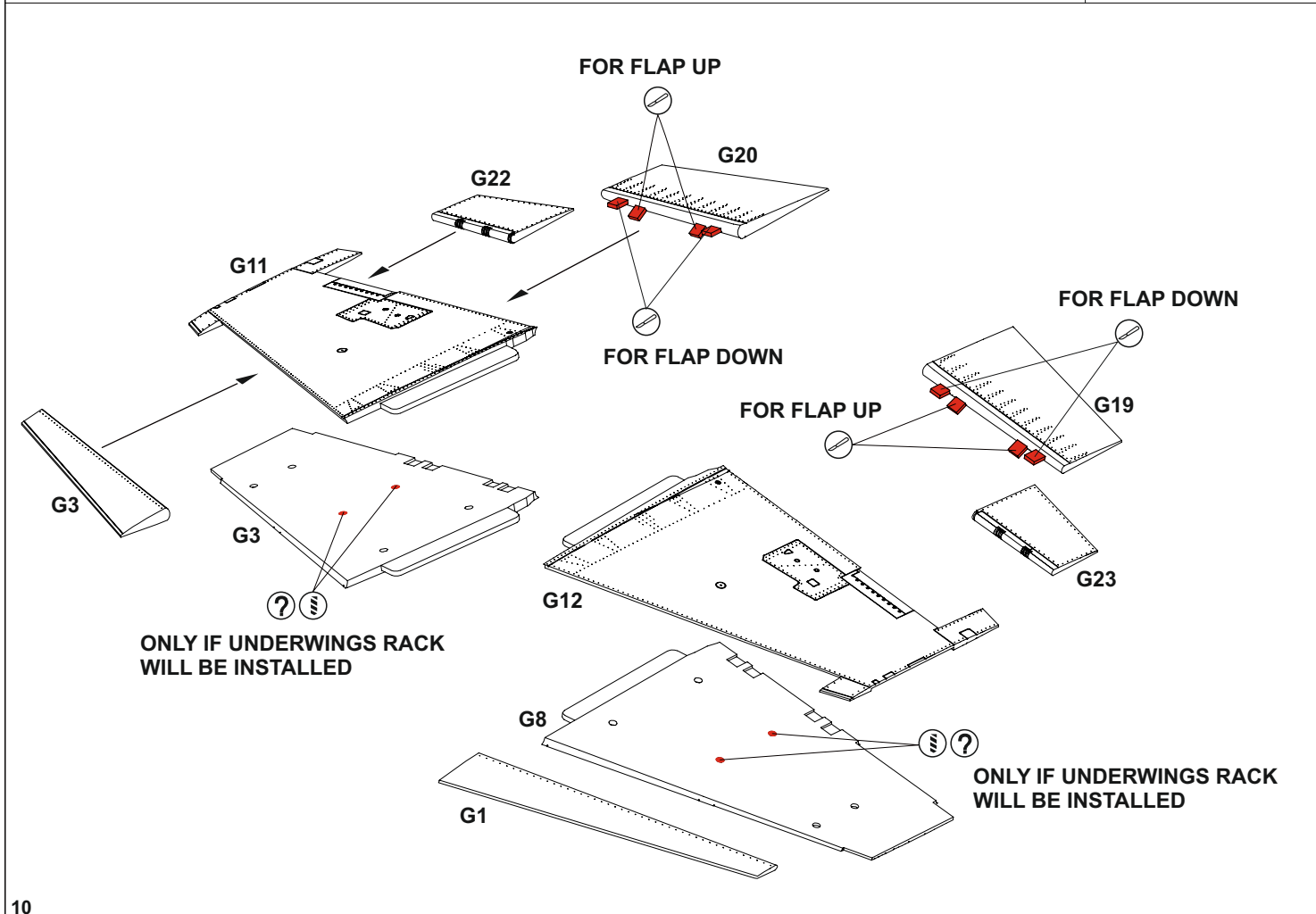
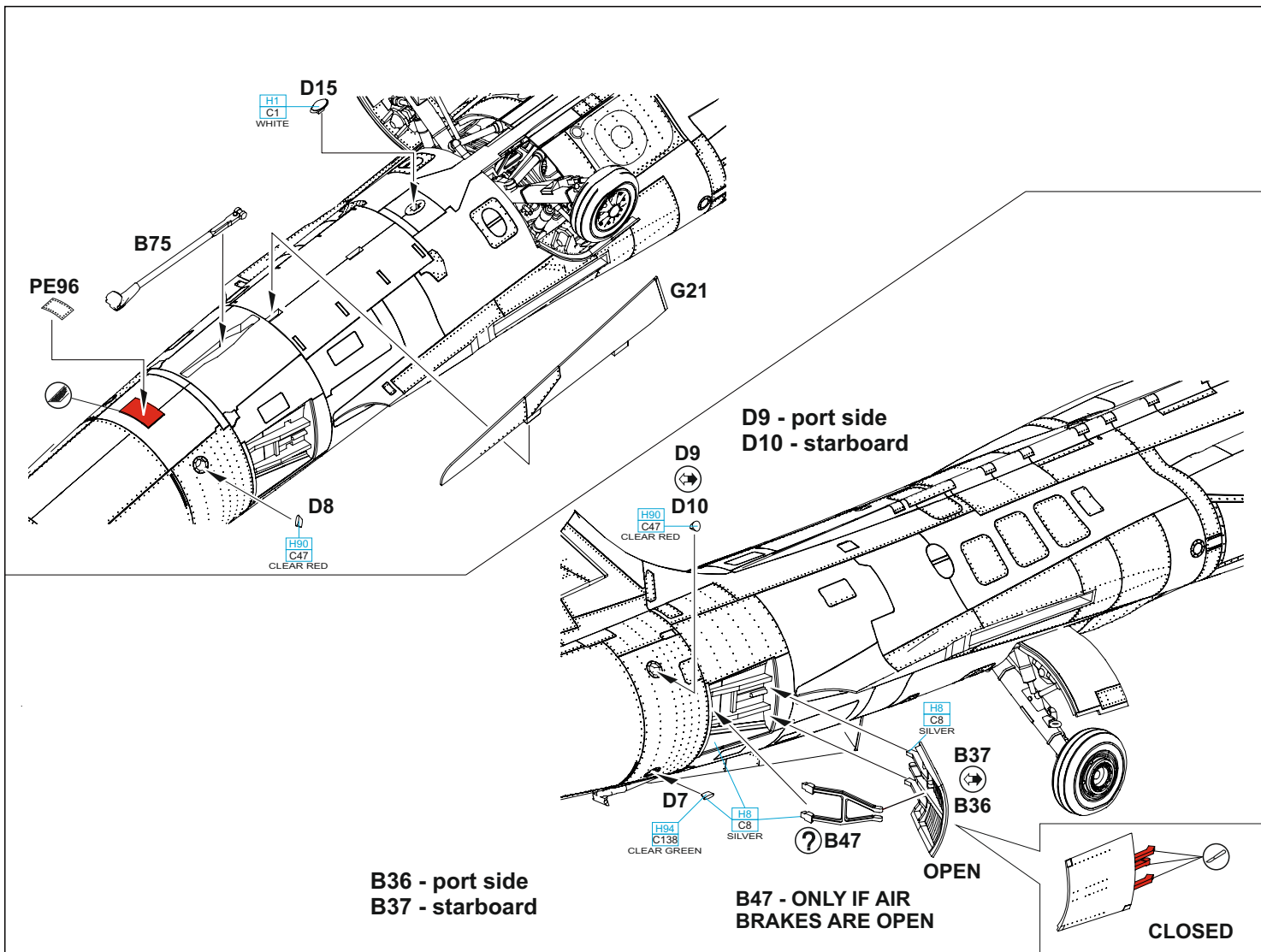



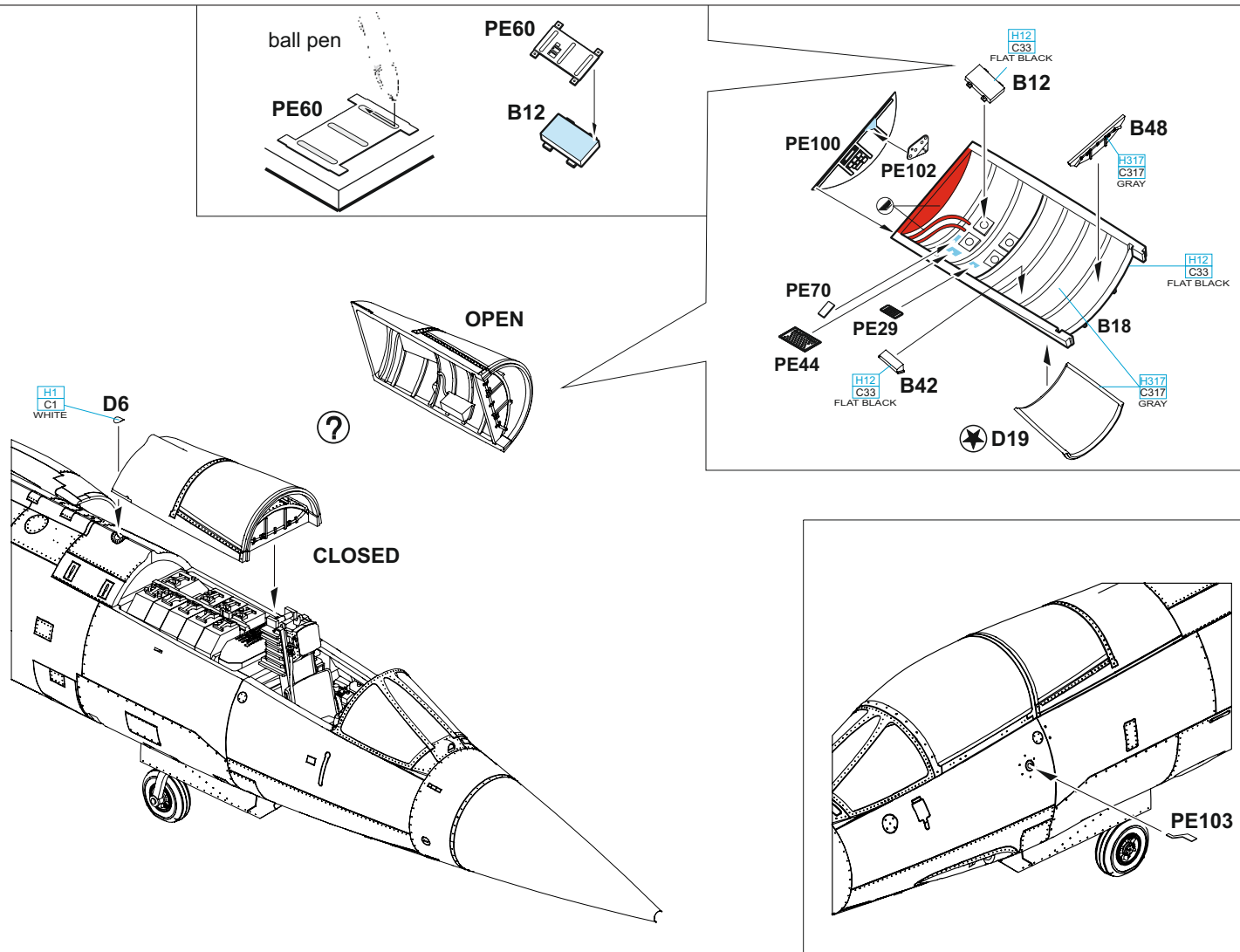
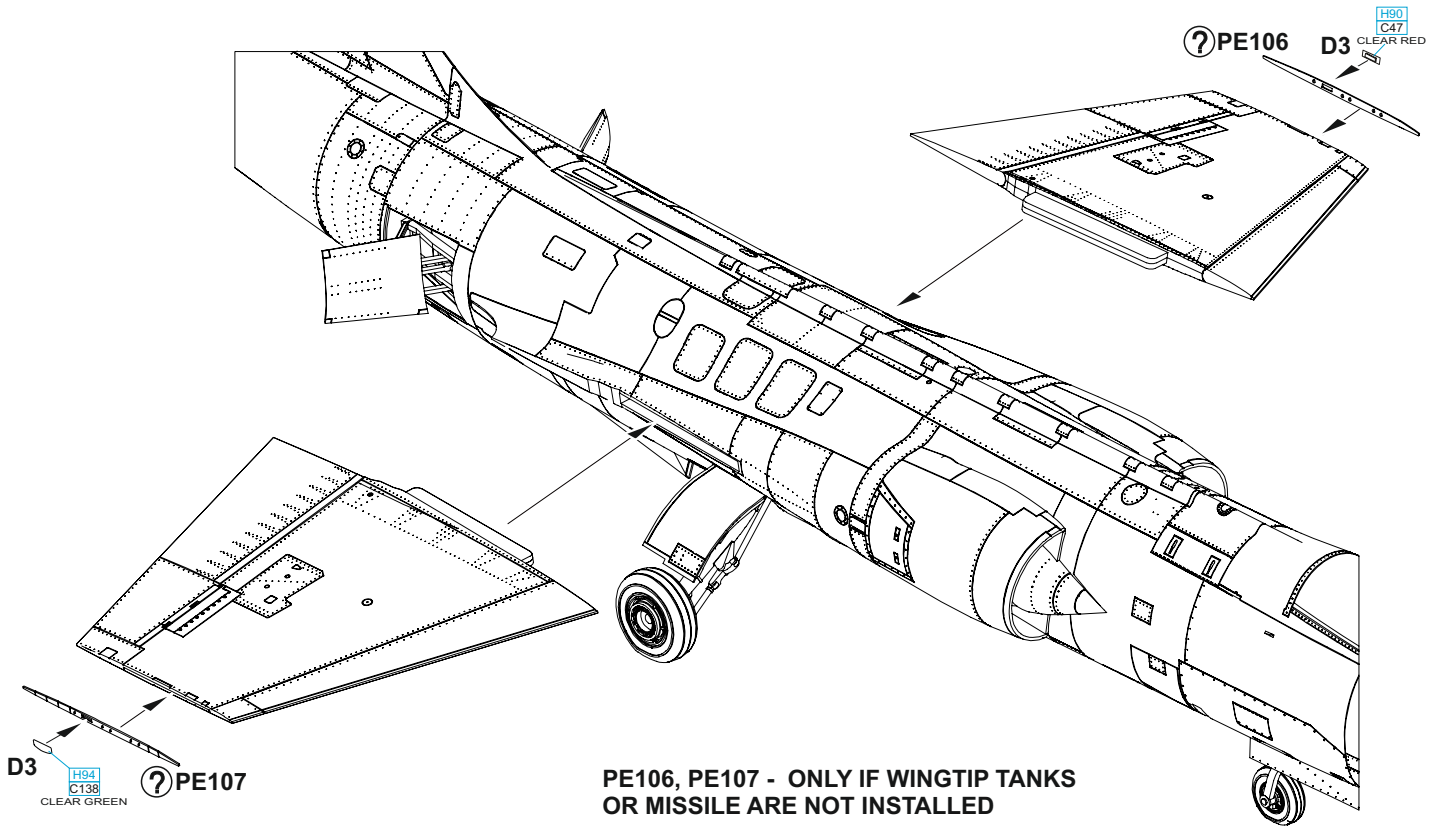

PE12, PE38, PE39 - INSTALL ONLY IF CANOPY IS OPEN

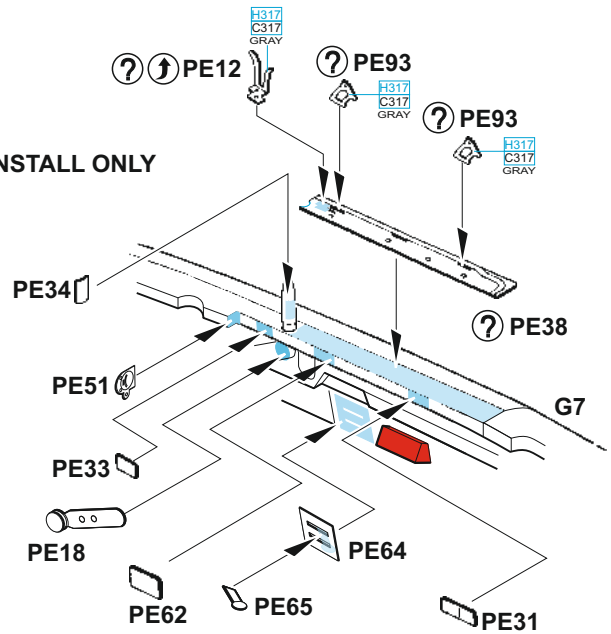
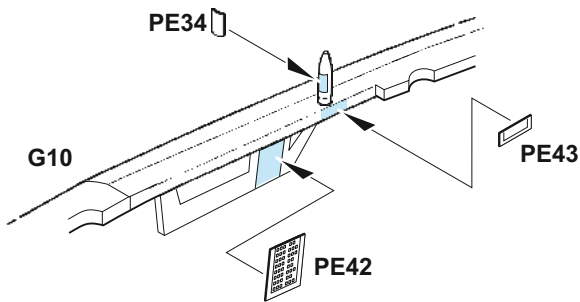

G

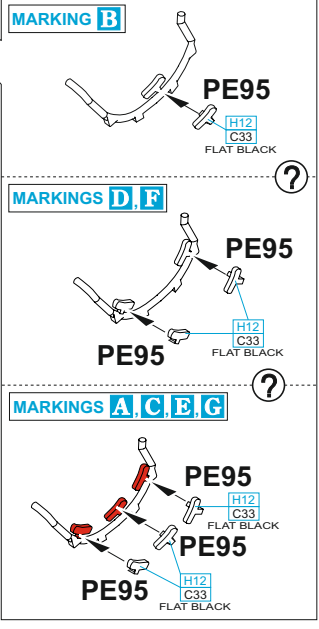
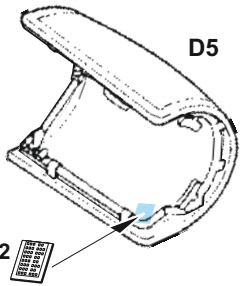
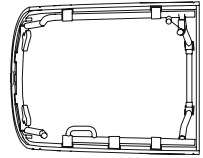
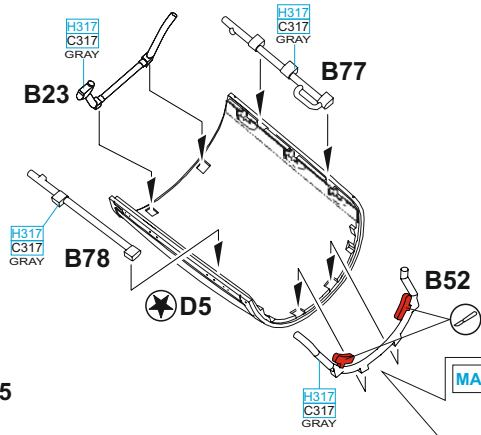
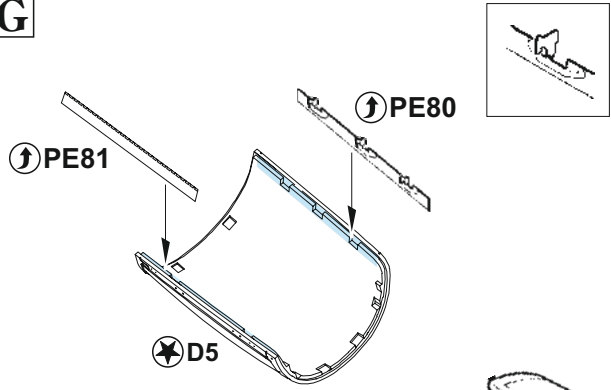

G

CLOSED CANOPY

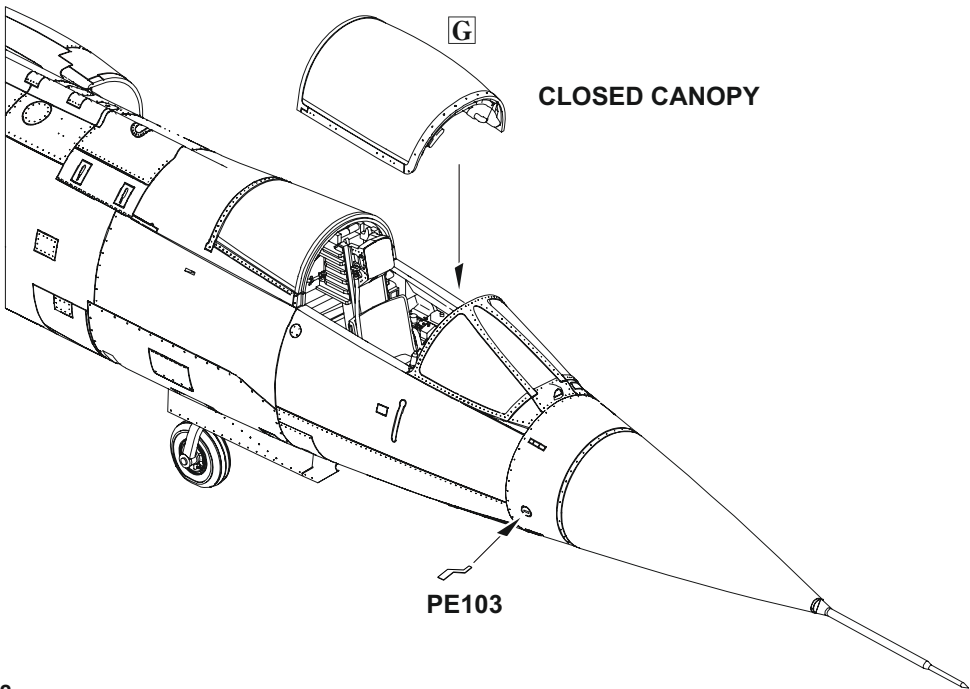

B53

G4

G

OPEN CANOPY

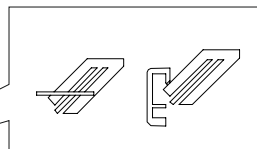
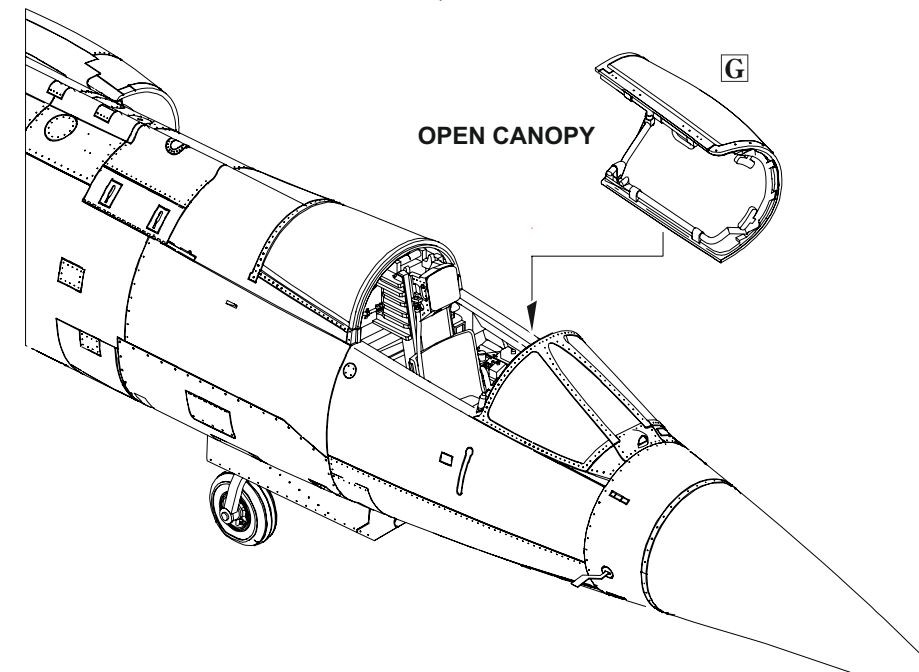

PE104 MC213 STEEL

PE94

H12 C33 FLAT BLACK

PE82

B27

D14

SM201 FINE SILVER

PE97

H12 C33 FLAT BLACK

PE82

PE94

H12 C33 FLAT BLACK

PE82

D4

H90 C47 CLEAR RED

D4

? R7

eduard BRASSIN

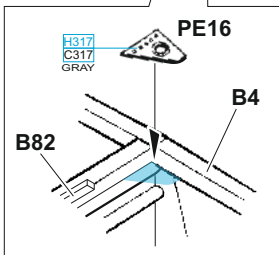

H317 C317 GRAY

PE16

B4

B82

R7 - MARKINGS A, C, E, F, G ONLY



**FUEL TANK FOR WINGTIPS ON STARBOARD**

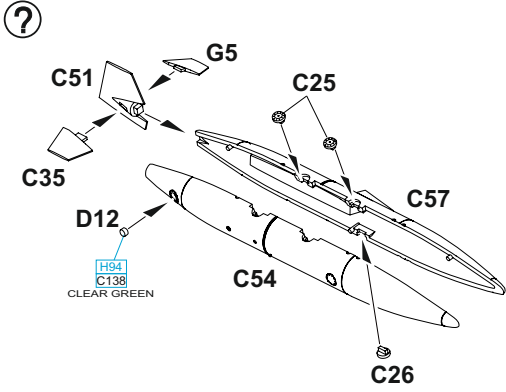

**UNDERWINGS TANK 2 pcs.**

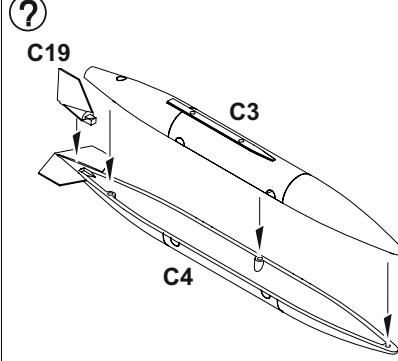

**FUEL TANK FOR WINGTIPS ON PORT BOARD**

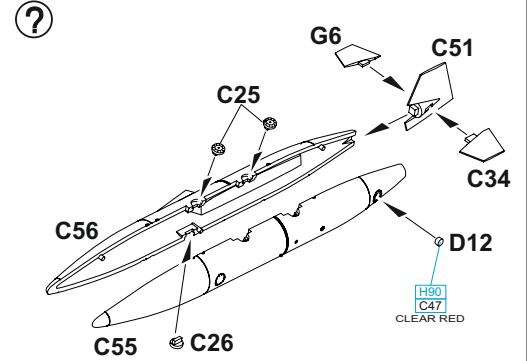

**RED DOG 2 pcs.**

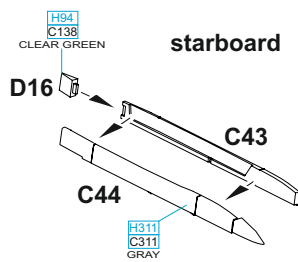
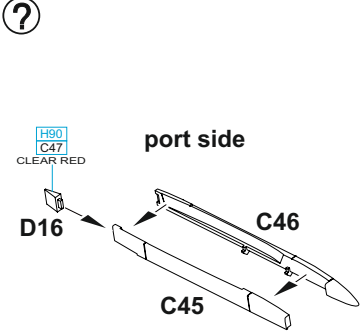

**AIM-9B 2 pcs.**

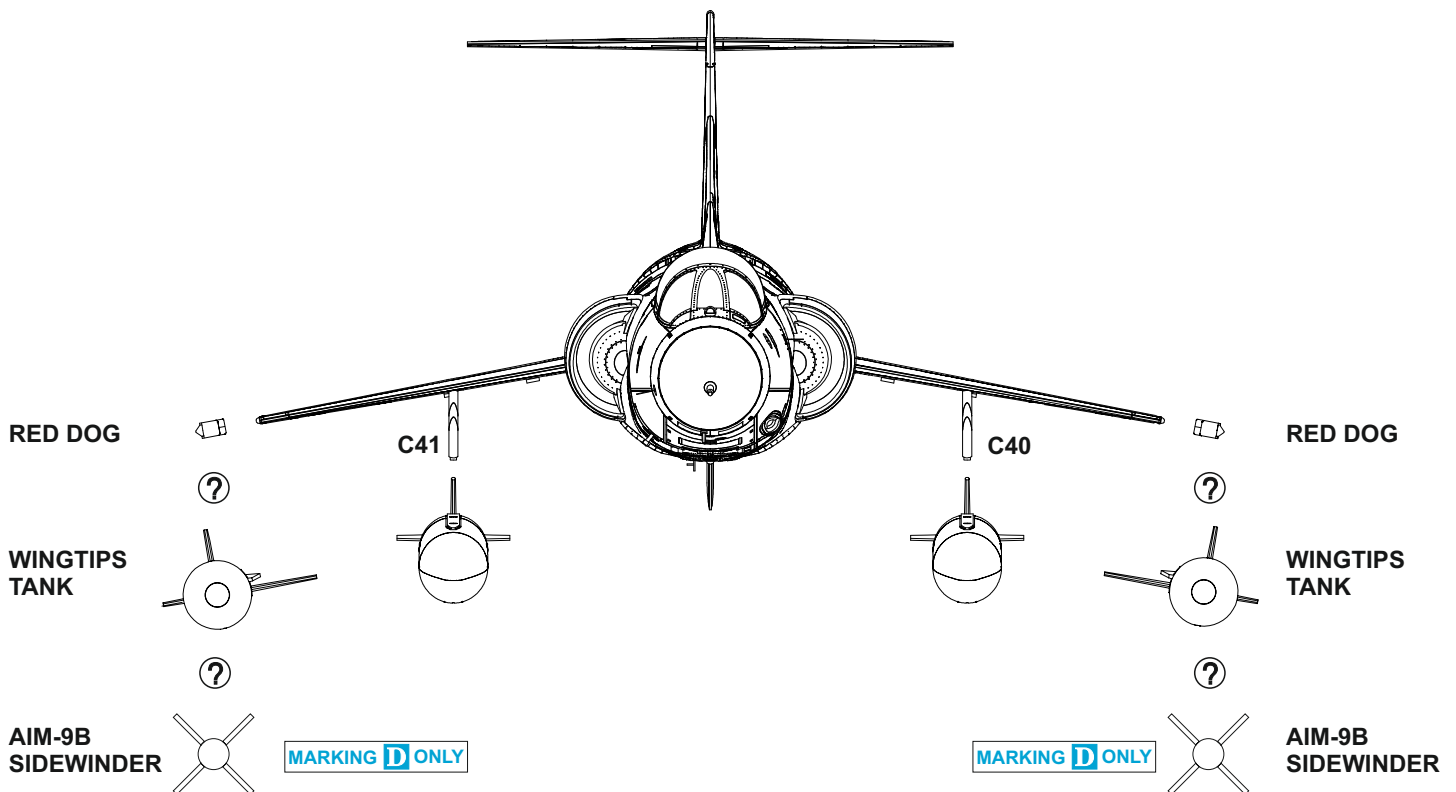
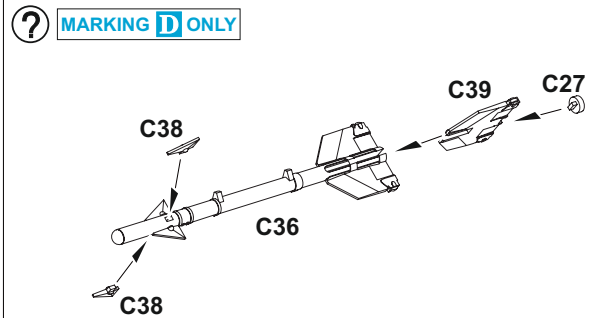

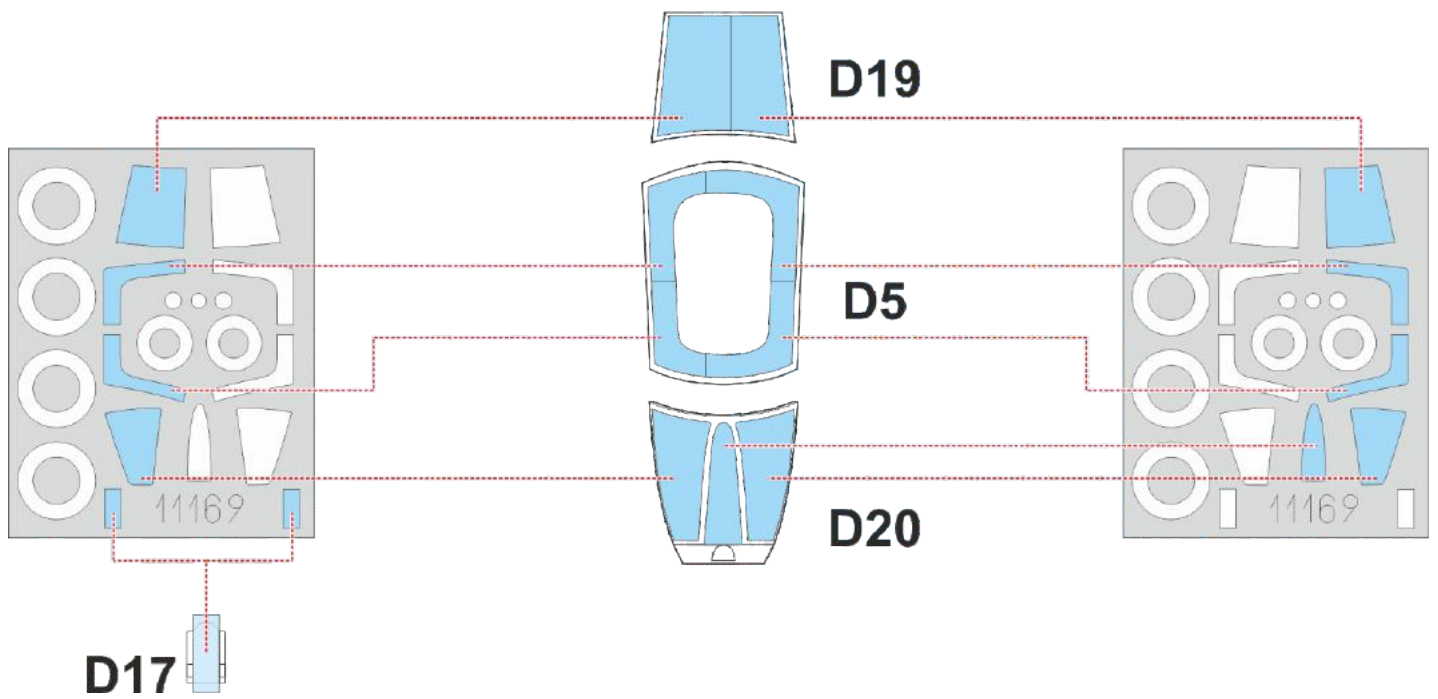
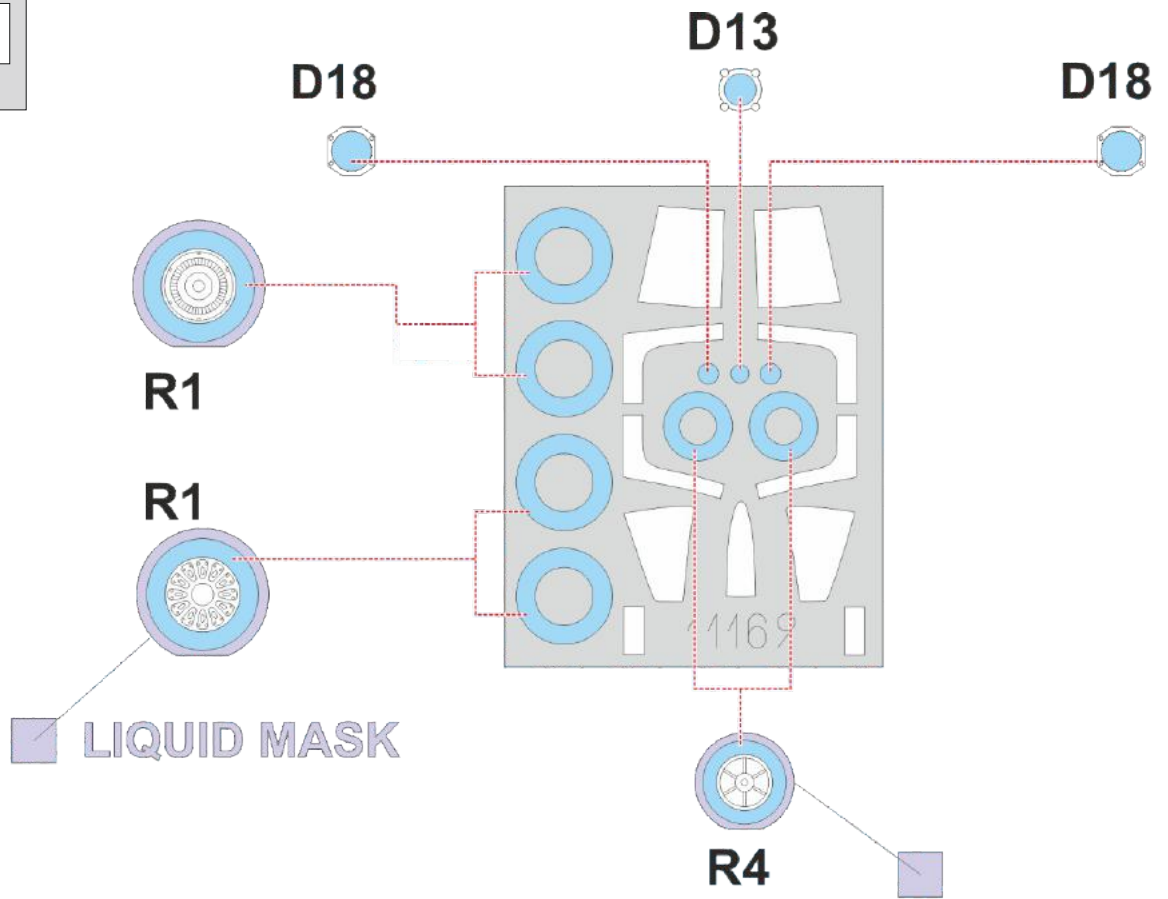

# A F-104C-5-LO, 56-0891, Maj. Charles H. Drisko, 435<sup>th</sup> TFS, 479<sup>th</sup> TFW, Udorn RTAFB, Thailand, 1967

F-104 serial number 56-0891 arrived in Udorn, Thailand, in January 1967. In the following months it was a personal mount of Major Herb Drisko, who had the ground personnel paint on the port side a cartoon of Snoopy wearing brown leather jacket and yellow scarf flying on the 20mm Vulcan Gatling Gun with its barrels blasting. Under Snoopy there was an inscription "SNOOPY SNIPER". The airplane's starboard was decorated with Herb's wife name Nancy J. After the operations were over, in June 1967 F-104 was flown over to the USA, to Muniz AFB in Puerto Rico. Charles Herbert Drisko, called Herb by his friends, was borne on October 26, 1928, in Bartlesville, OK and after he graduated from the high school, during the period after the war, he worked in the oil fields in Wyoming. In July 1951 he joined the Air Force and after completing the training and receiving his officer's commission he served in the Korean War as a radar operator on F-89 out of Okinawa. After that he completed his pilot training and during the Vietnam war flew F-104. He left the Air Force in 1971 with the rank of Lieutenant Colonel. Herb Drisko passed away on October 26, 2000.

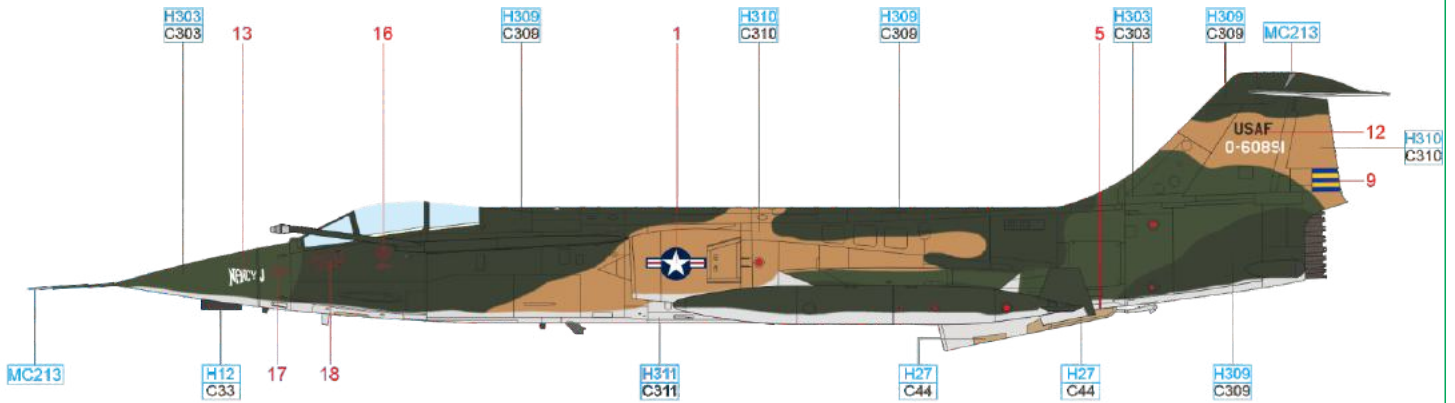

ČESKOU VERZI TEXTU NALEZNETE NA  
[www.eduard.com](http://www.eduard.com)  
 POD KATALOGOVÝM ČÍSLEM 11169

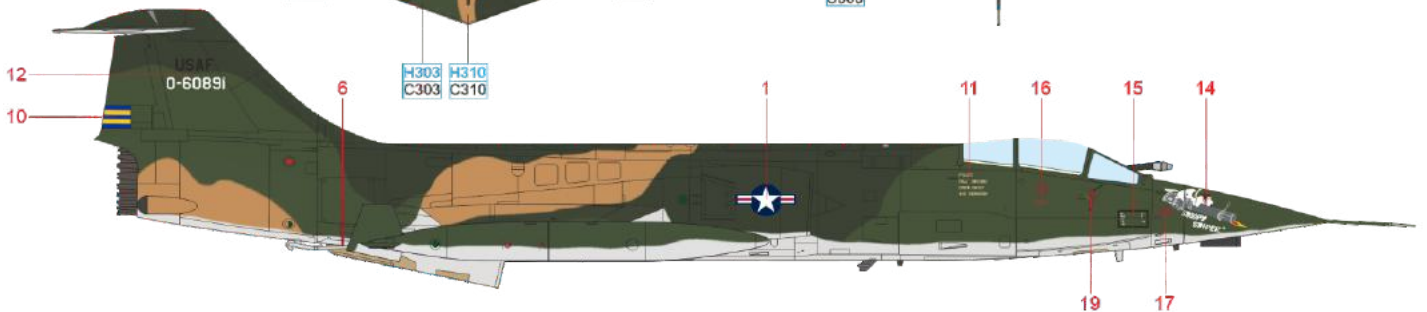
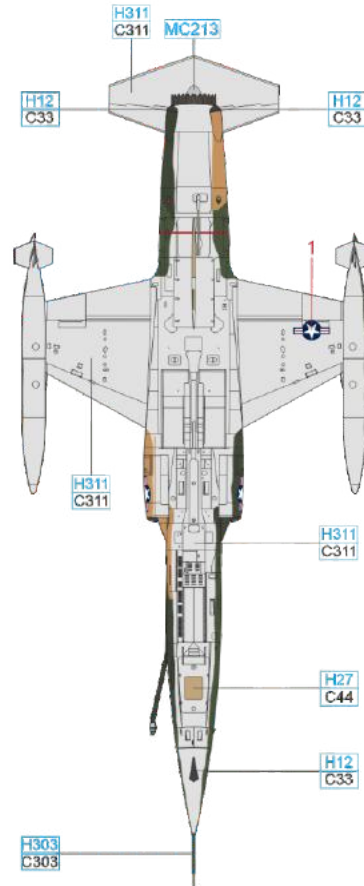
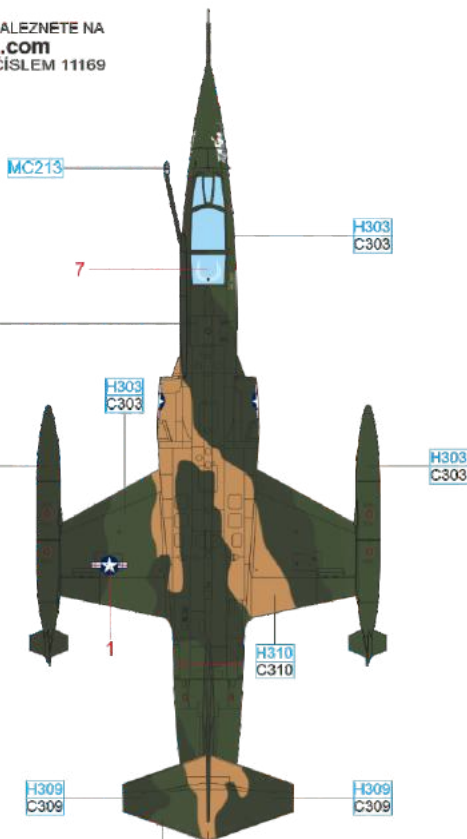

BROWN	H310 C310	GRAY	H311 C311	FLAT BLACK	H12 C33
GREEN	H303 C303	GREEN	H309 C309	TAN	H27 C44
				STAINLESS	MC213



# B F-104C-5-LO, 56-0891, Col. George Laven Jr., 479<sup>th</sup> TFW, George AFB, California, United States, 1959

"SNOOPY SNIPER" history was very colorful. The aircraft serial number 56-0891 was received on October 15, 1958 as the first C-version airframe at Nellis AFB in Las Vegas, Nevada. The aircraft was christened Really George as its home base was supposed to be 479<sup>th</sup> TFW at George AFB, California. The aircraft was assigned to the commander, Col. George Laven Jr., who was a WWII ace credited with five kills. Same as his previous personal aircraft. Laven's new F-104 sported rather gaudy coloration which gradually developed to the point that the superior officers ordered its removal as it was deemed too wild. It was followed by the more moderate blue coat with four stripes representing colors of all four 479<sup>th</sup> TFW squadrons. George Laven Jr. was a self-confident Texan known for his daring style of flying. He joined the USAAF in the end of December 1940 and completed his pilot training in August 1941. He gained his fame during his service with 343<sup>rd</sup> FG flying P-38s and 54<sup>th</sup> FG in Alaska where he guided P-39s. During this period he scored four aerial victories and he destroyed almost two dozens of locomotives in Europe. In March 1945 he was assigned to the 49<sup>th</sup> FG Headquarters but regardless he flew combat as much as possible and on April 26, 1945 he shot down H8K2 as his fifth kill. After the war he continued in the service. At George AFB he commanded several groups and wings. In the end of 1950s he was in the command of the 479<sup>th</sup> TFW. He retired as a veteran of three wars and in 1969 he became a McDonnell Douglas consultant in Israel. He continued flying F-4 Phantom II and F-15 Eagle.

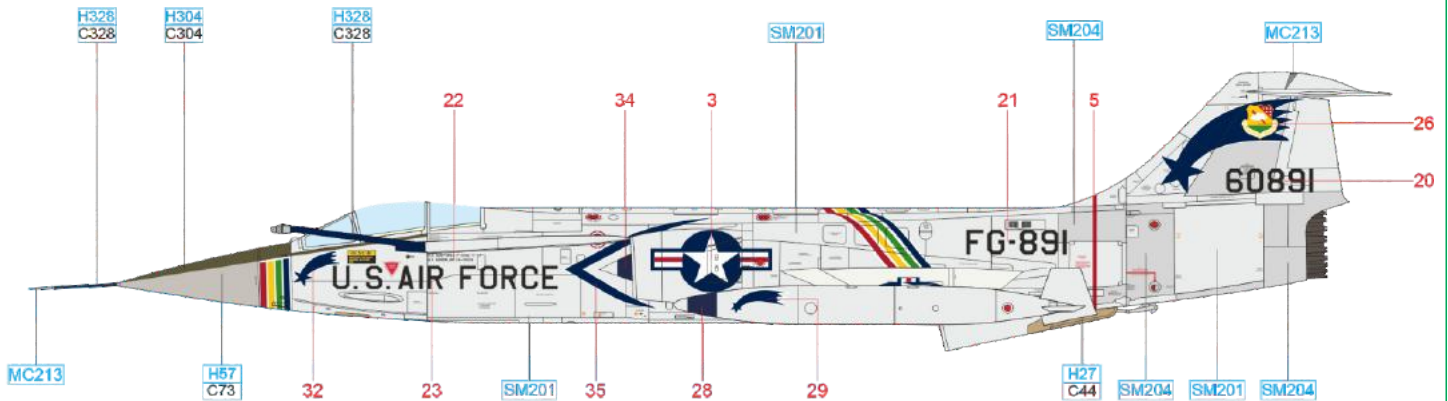

ČESKOU VERZI TEXTU NALEZNETE NA  
[www.eduard.com](http://www.eduard.com)  
 POD KATALOGOVÝM ČÍSLEM 11169

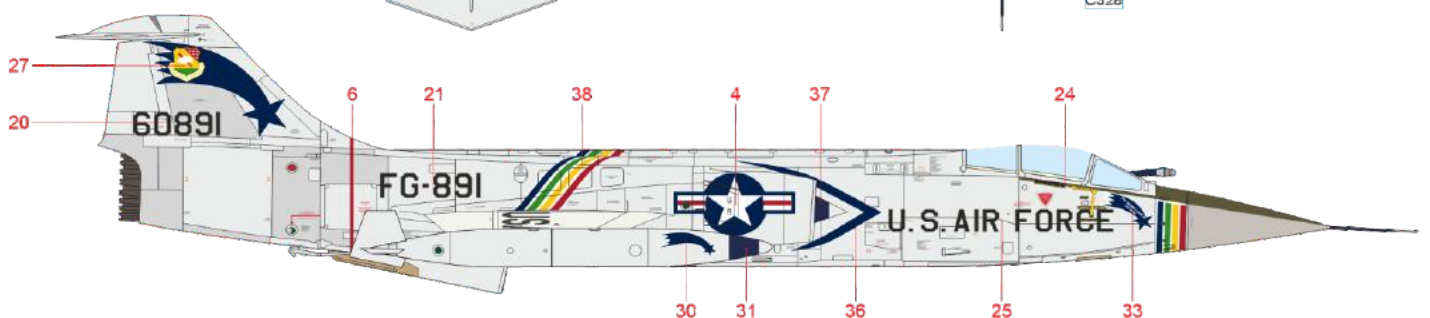
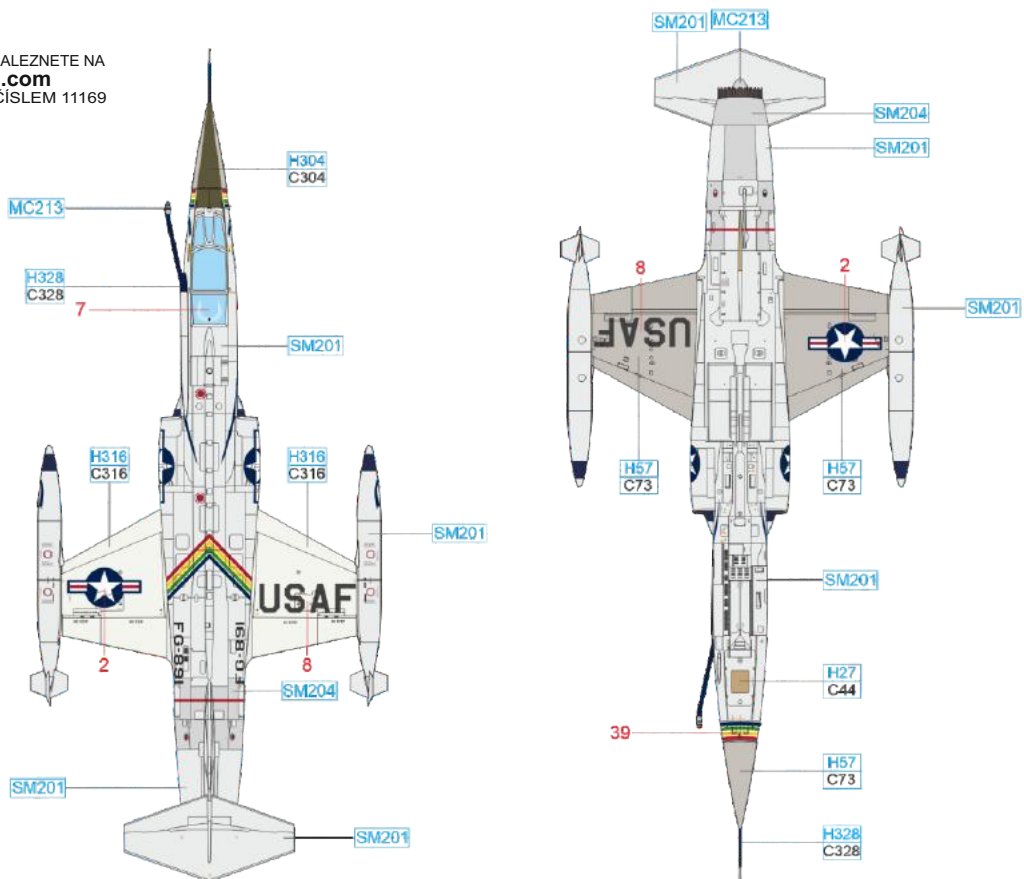

SUPER STAINLESS 2	SM204	AIRCRAFT GRAY	H57 C73	BLUE	H328 C328	TAN	H27 C44
SUPER FINE SILVER 2	SM201	WHITE	H316 C316	OLIVE DRAB	H304 C304	STAINLESS	MC213

F-104 serial number 57-0923 arrived in Udorn on September 19, 1966. It was assigned to the flight commander Lt. Col. Robert Preciado who let both sides of his aircraft nose painted with the nickname of his wife Dolly Helloo Dolly, long Helloo coming from the famous musical Hello Dolly starring Barbra Streisand. After the operations in Udorn were completed, the aircraft was flown back to the USA where, in July 1967, it arrived in Muniz AFB in Puerto Rico. Starting in August 1968 it was assigned to the 198<sup>th</sup> TFS. Robert Preciado was a veteran of three wars. During WWII he flew in the Pacific with the Air Transport Command and continued his aviation career in Korea and Vietnam.

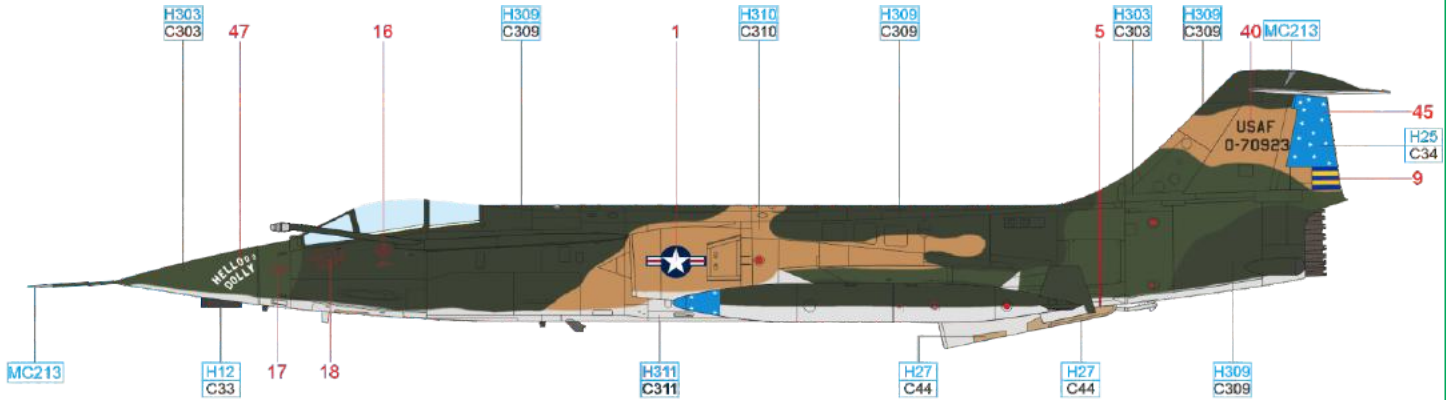

ČESKOU VERZI TEXTU NALEZNETE NA  
**www.eduard.com**  
POD KATALOGOVÝM ČÍSLEM 11169

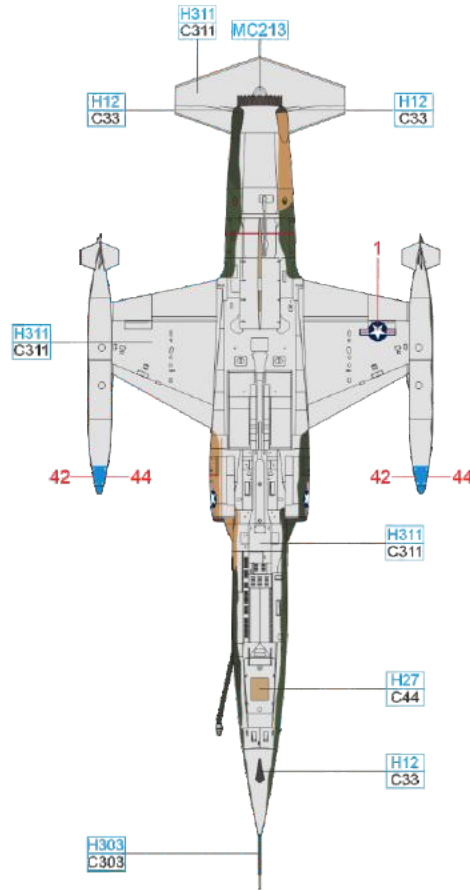
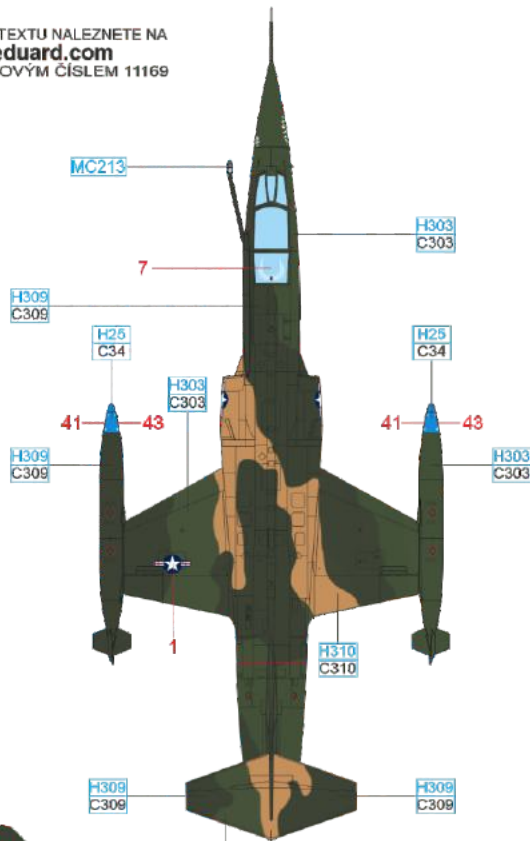

SKY BLUE	H25 C34	FLAT BLACK	H12 C33	BROWN	H310 C310	GRAY	H311 C311
GREEN	H303 C303	GREEN	H309 C309	TAN	H27 C44	STAINLESS	MC213





# E F-104C-5-LO, 56-0910, Capt. James B. Trice, 435<sup>th</sup> TFS, 479<sup>th</sup> TFW, Udorn RTAFB, Thailand, 1967

One of the first F-104 delivered to the Udorn AFB on June 6, 1966 was Starfighter serial number 56-0910. It was assigned as a personal mount to Capt. James Trice who had his Starfighter nose decorated with a nose art with the inscription PUSSYCAT. Initially the noseart consisted of the cat caricature only, the text was applied later. After the operations in Udorn ceased, in July 1967 the aircraft was flown back to the USA to the Muniz AFB in Puerto Rico and starting in August 1967 it was assigned to the 198<sup>th</sup> TFS.

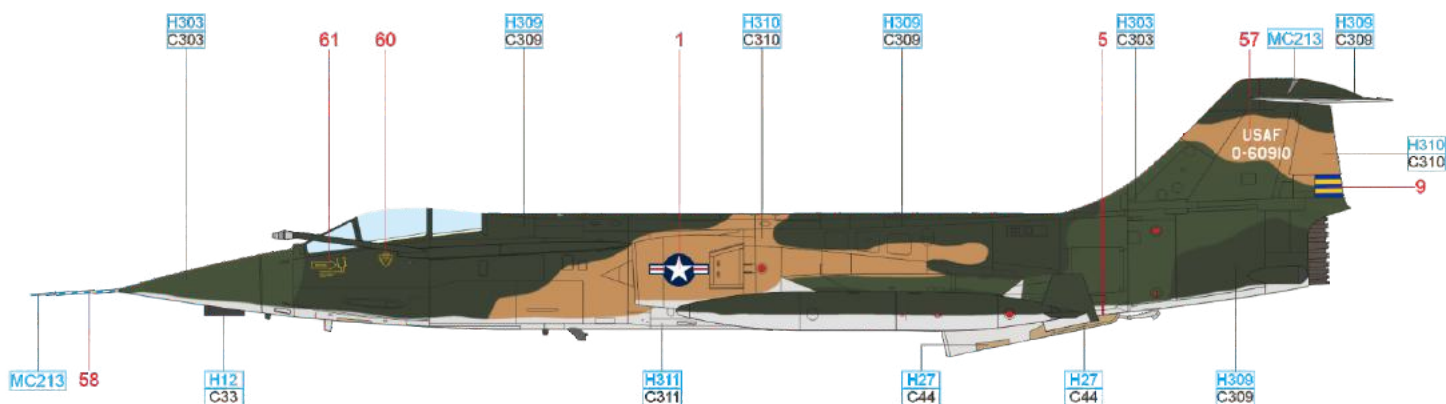

ČESKOU VERZI TEXTU NALEZNETE NA  
[www.eduard.com](http://www.eduard.com)  
 POD KATALOGOVÝM ČÍSLEM 11169

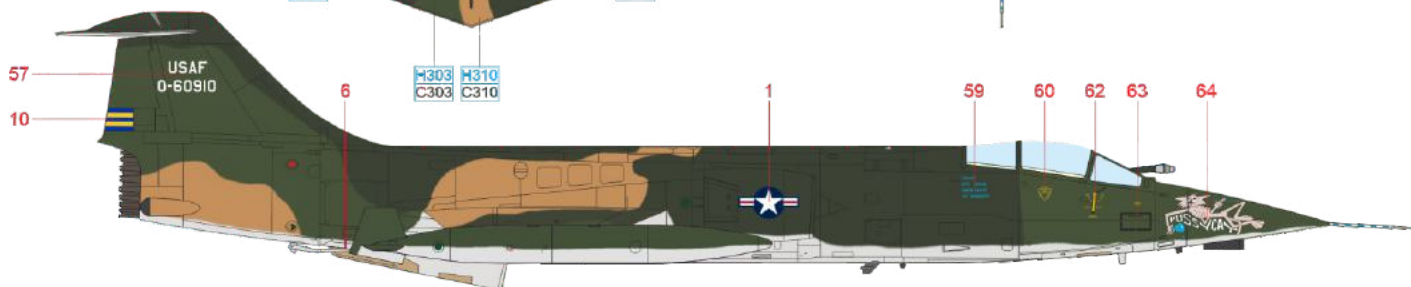
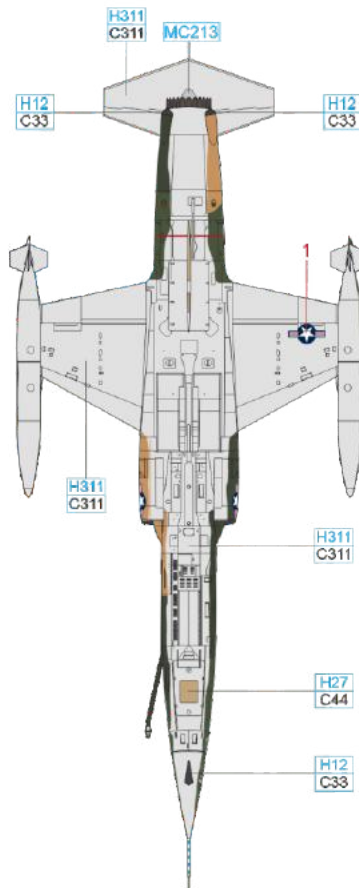
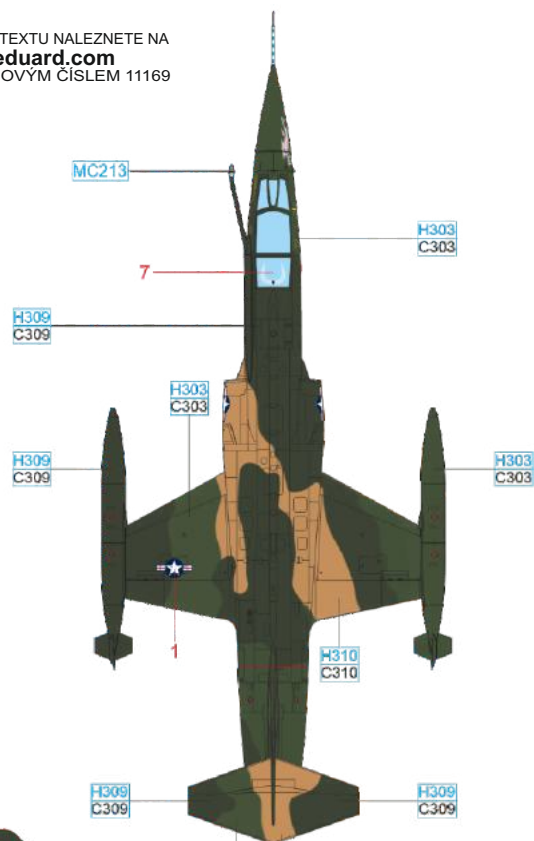

GRAY	H311 C311	TAN	H27 C44	FLAT BLACK	H12 C33
GREEN	H303 C303	GREEN	H309 C309	BROWN	H310 C310
				STAINLESS	MC213

**F** F-104C-5-LO, 56-0938, Maj. Bobby D. Betsworth, 435<sup>th</sup> TFS, 479<sup>th</sup> TFW, Udorn RTAFB, Thailand, June-August 1967

This Starfighter was one of the first eight aircraft of this type delivered to the Udorn AFB on June 6, 1966. It was typically flown by Maj. Bobby Bedsworth who hailed from Missouri nicknamed Show Me State. For that reason the nose of his aircraft was decorated with a mule and this inscription. After the operations in Udorn ceased, on August 20, 1967 the airplane was flown back to the USA to the Muniz AFB in Puerto Rico.

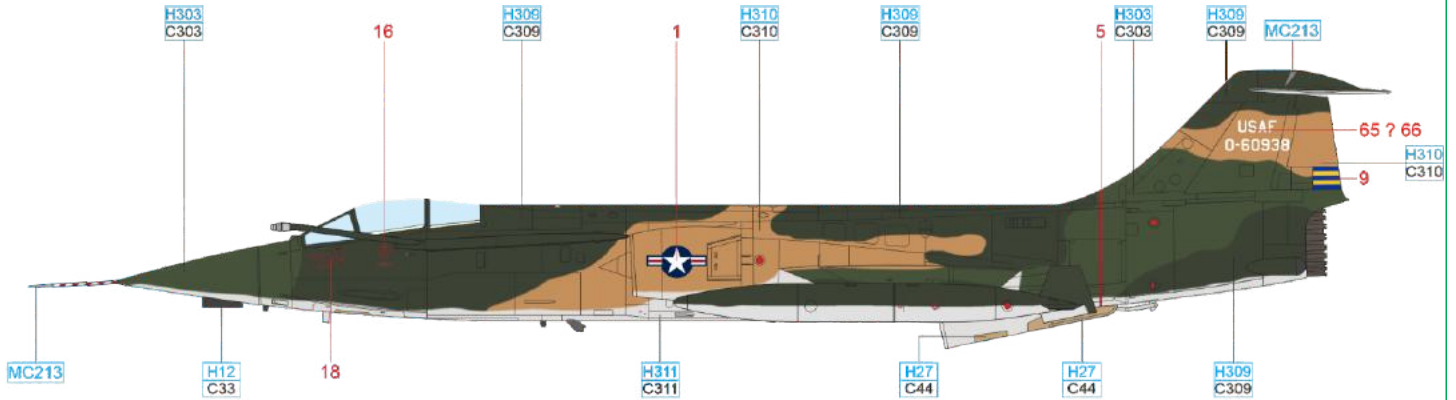

ČESKOU VERZI TEXTU NALEZNETE NA  
[www.eduard.com](http://www.eduard.com)  
POD KATALOGOVÝM ČÍSLEM 11169

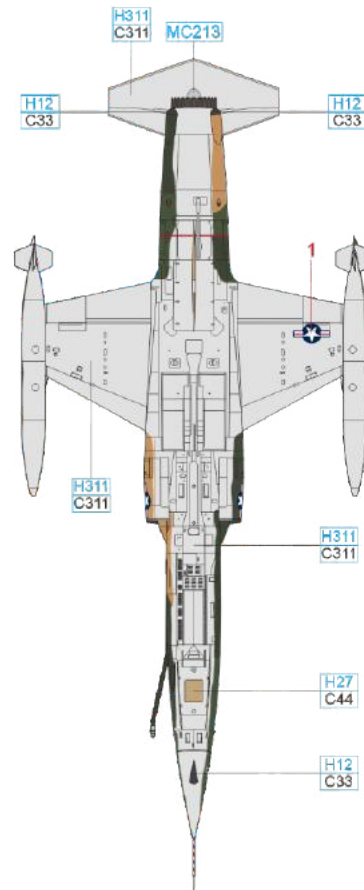
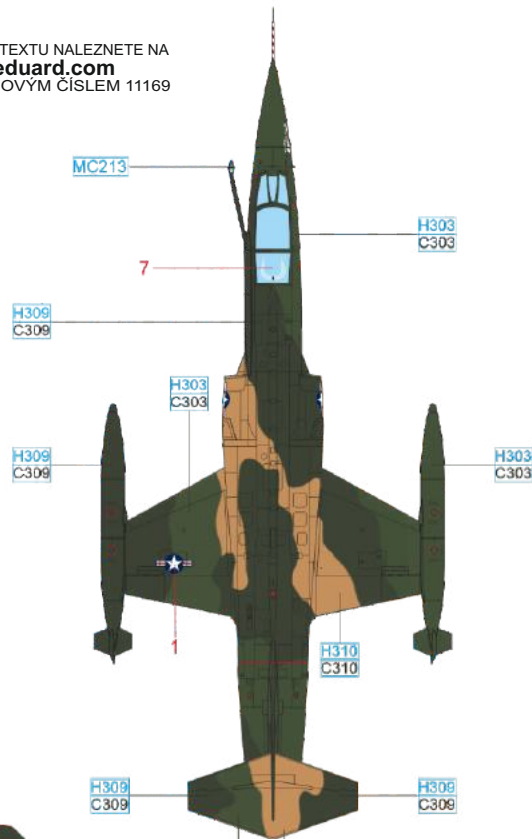

GRAY	H311 C311	TAN	H27 C44	FLAT BLACK	H12 C33
GREEN	H303 C303	GREEN	H309 C309	BROWN	H310 C310
				STAINLESS	MC213

This Starfighter took part in the very first mission in Vietnam in 1965. After the overhaul it was one of twelve aircraft which on July 22, 1966 landed at Udorn. During the following combat missions it was mostly flown by Maj. Hugh Spencer. In March 1967 the pin up girl named SEX MACHINE was painted on the aircraft's nose. After the operations in Udorn were completed, in July 1967 the aircraft was flown back to the USA to the Muniz AFB in Puerto Rico and in August 1967 it was assigned to the 198<sup>th</sup> TFW. Currently the aircraft is on display in the Kalamazoo Air Zoo Aviation History Museum in its original markings carried while flying at 434<sup>th</sup> TFS, the large fuselage number FG-898 and red markings.

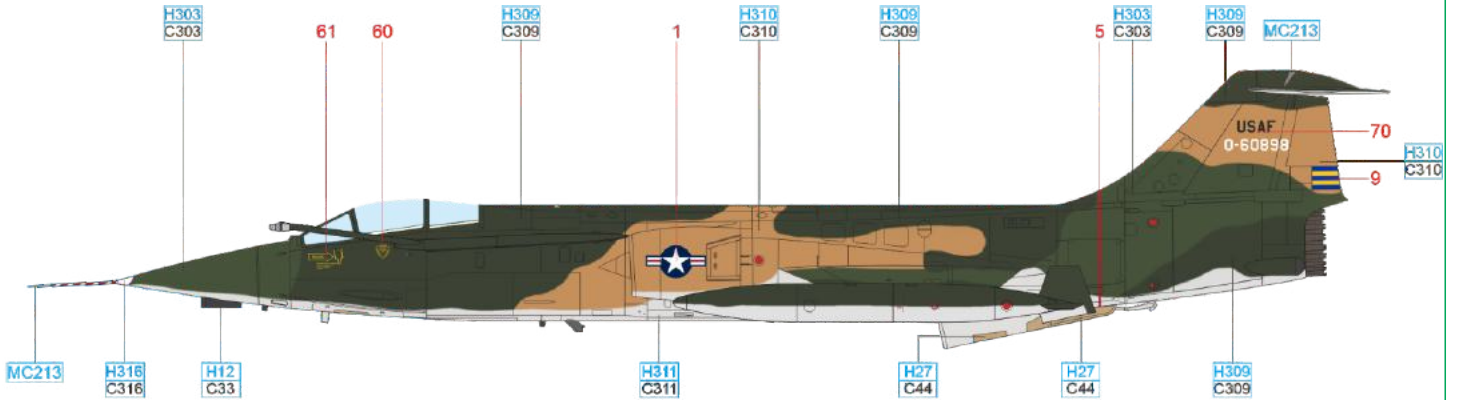

ČESKOU VERZI TEXTU NALEZNETE NA  
[www.eduard.com](http://www.eduard.com)  
 POD KATALOGOVÝM ČÍSLEM 11169

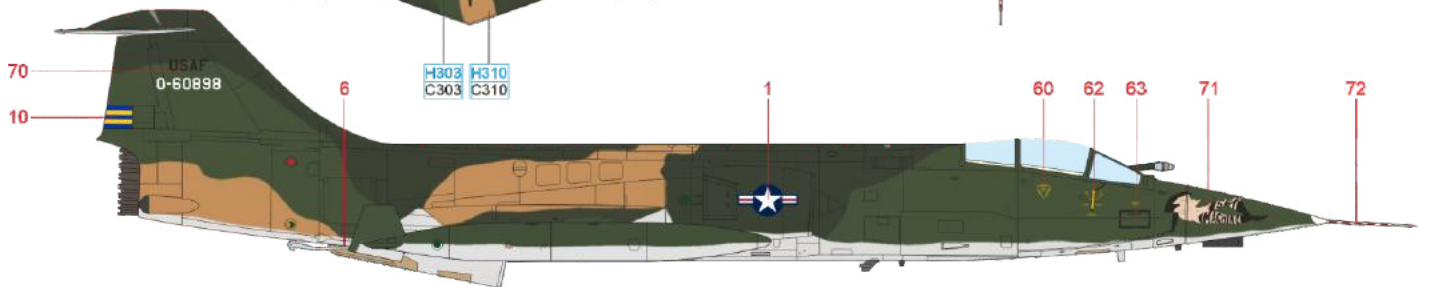
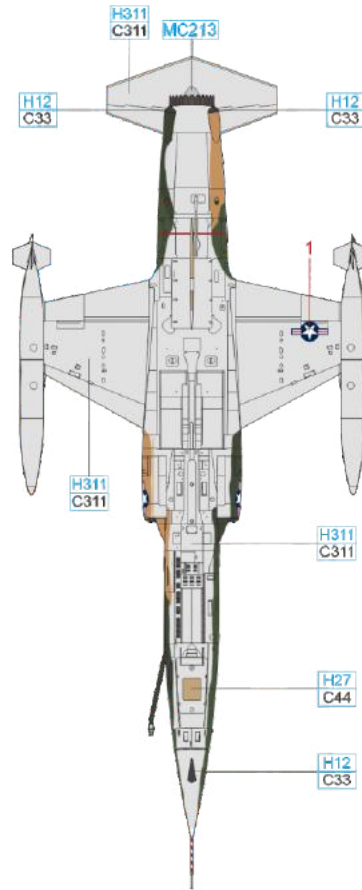
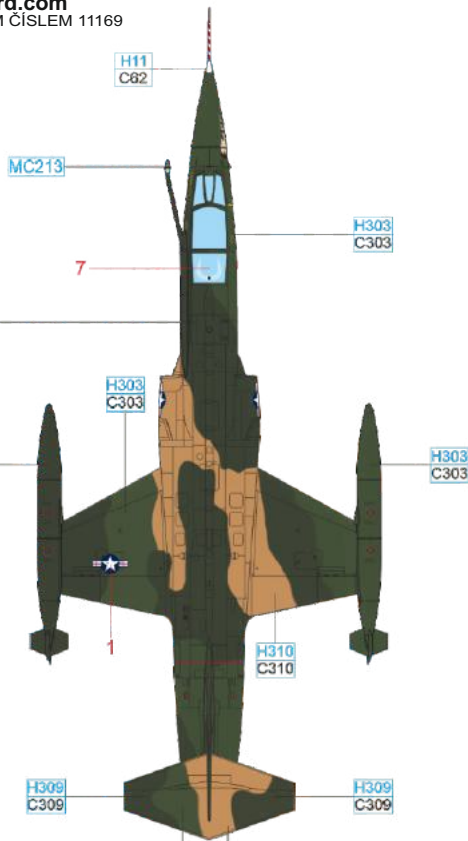

FLAT BLACK	H12 C33	WHITE	H316 C316	BROWN	H310 C310	GRAY	H311 C311
GREEN	H303 C303	GREEN	H309 C309	TAN	H27 C44	STAINLESS	MC213

