

HIGH PLANES MODELS YAKOVLEV YAK 9P/U

Late War Russian Fighter

Kit No 72037



Construction Notes. Carefully cut all parts from their sprues, wash pieces in warm soapy water to remove mould release agent, and test fit parts before gluing. It will be necessary to remove flash and prepare mating surfaces to ensure a good fit. Careful preparation will be rewarded with a better finished model.

Perhaps the first job should be to cut out the canopy. With this ready, the fuselage halves can be trial fitted and material removed or added to the mating surfaces to ensure a snug side to side fit of the canopy.

Next, join the instrument panel and rear radio shelf to fuselage inner side.

Prepare a piece of plastic card to fit inside the fuselage lower half cut-out in the region of the radiator; this will provide a bit of a floor between the fuselage and wing. If modelling the Yak 9Ps then cut out the opening on the rear fuselage for the DF loop transparency, and install a floor and circular DF loop.

Glue fuselage sides together.

Glue top and bottom of wings together, install seat back and pan into position and then glue wing to fuselage. Add tailplanes and ensure alignment. Cut another piece of plastic card to replicate the radiator inside the bath, and the whole unit can then be glued up under the wing.

Drill a small hole in which to mount the tail wheel, and others in the main wells to mount the main undercarriage legs, referring to the drawings for correct angles.

Assemble propellor unit to the spinner and backing plate. This can either be glued into position or a shaft incorporated on which it can mount. Add the two gun blisters to the marked location above the nose, and the small intake between them.

Fit main undercarriage legs with super glue or Araldite etc, add wheels, and then undercarriage doors. Add wheels after referring to drawings for angles.

Drill small hole in rear canopy and construct an aerial which will insert into radio rack below; likewise prepare a sprue or wire pitot tube to fit on the port wing leading edge.

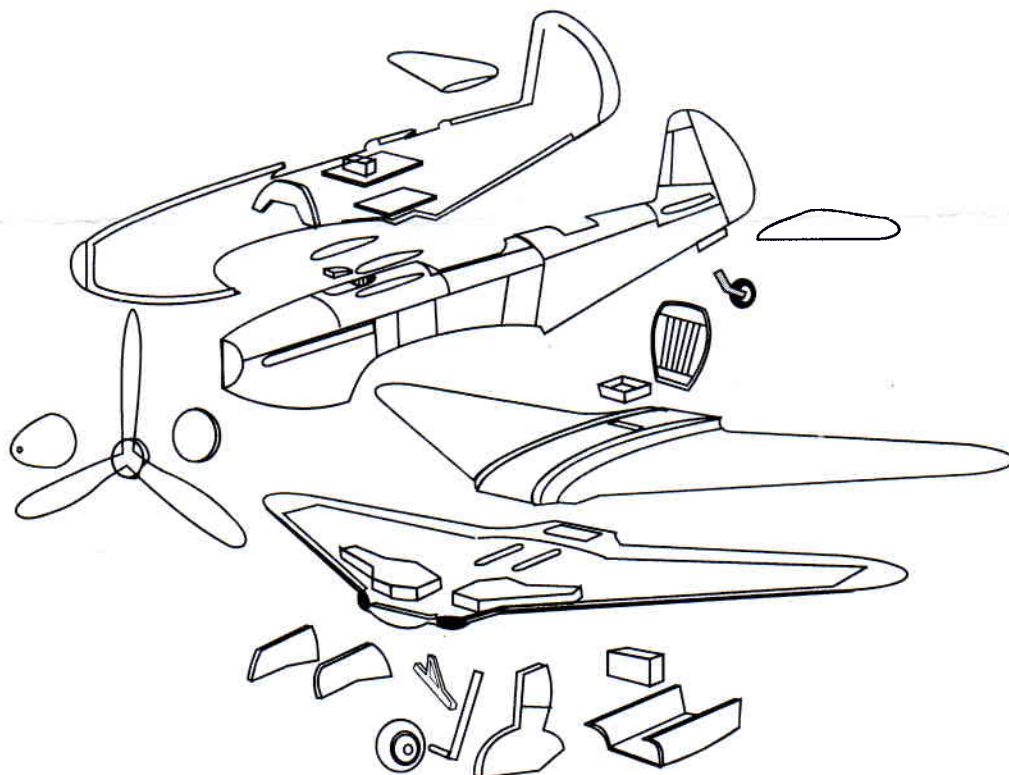

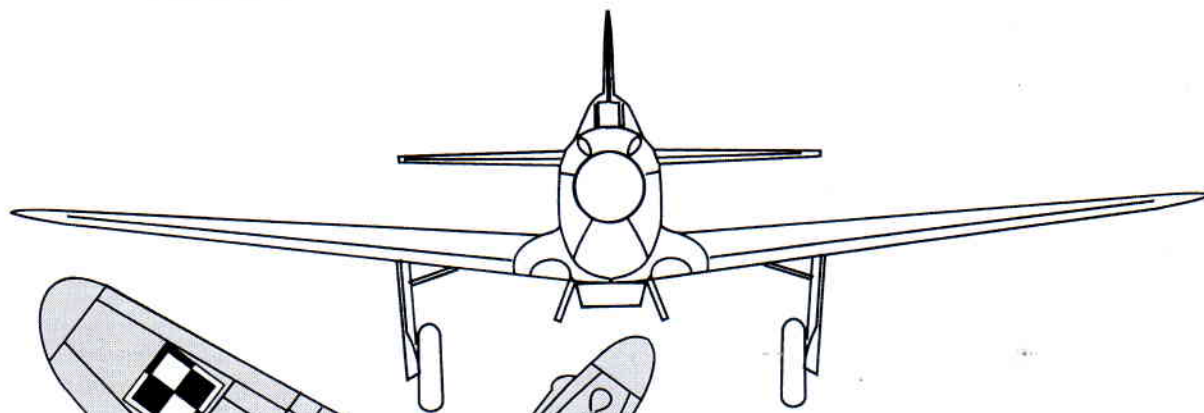

Polish insignia placement both sides.

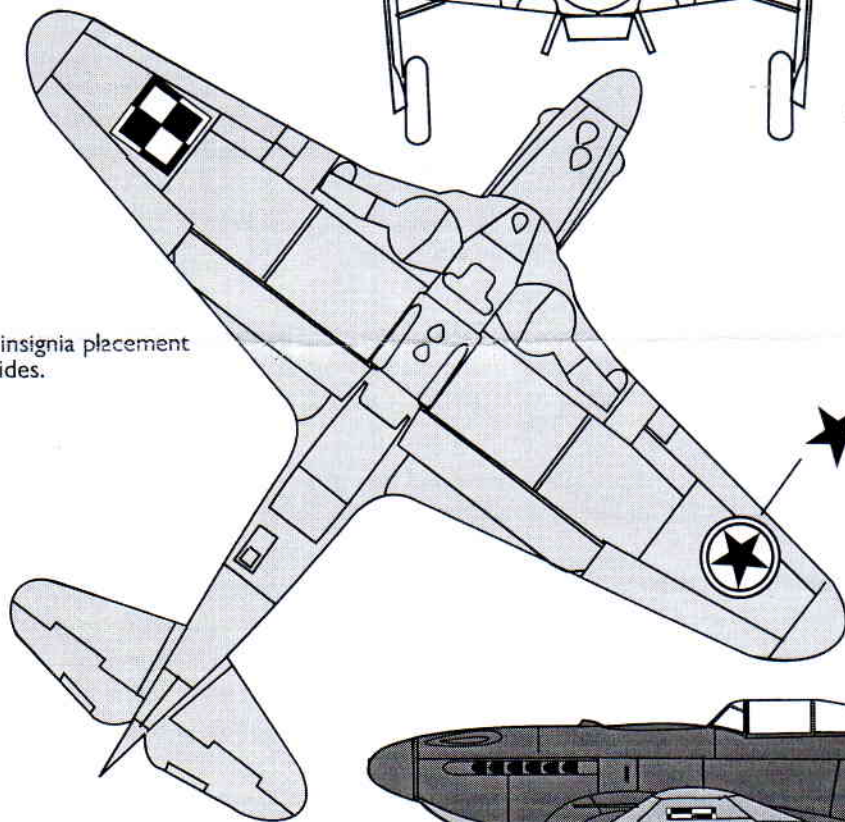

Position of underwing markings both sides of North Korean and Russian aircraft.

Polish Yak 9P in Dark Olive Green, with Sky Blue undersides. No upper wing markings.

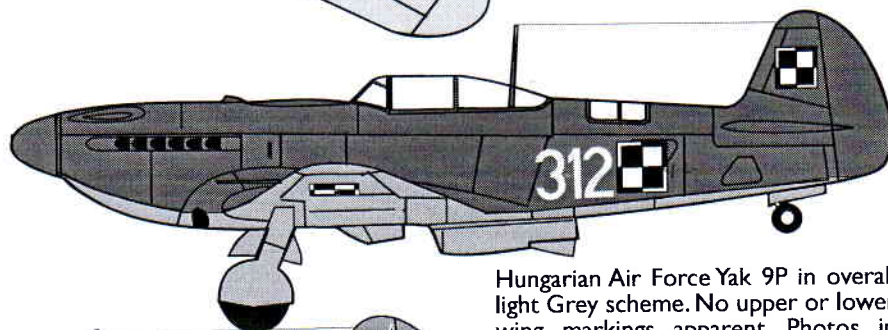

Hungarian Air Force Yak 9P in overall light Grey scheme. No upper or lower wing markings apparent. Photos in Squadron Signal Yak book show patches which are claimed as camouflage, but more likely paint touch up in areas of hinges etc.

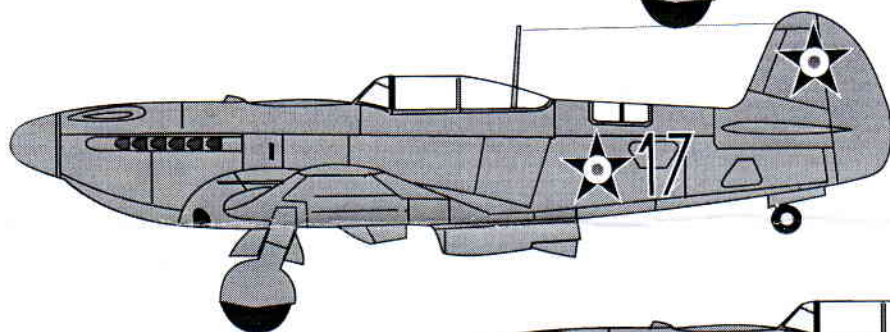

North Korean Yak 9P captured by UN forces at Kimpo early during the Korean War. Colour a mid grey about FS 36440. No upper wing roundels. Colour photos Wings of Fame No 1, and Osprey Korea-The Air war 1950-1953.

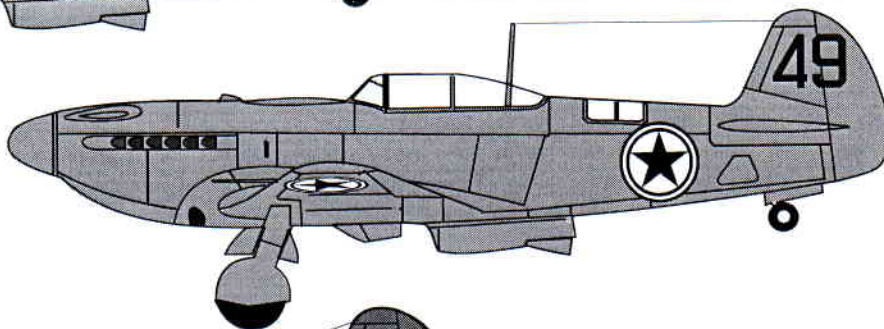

Yak 9U of the Soviet Air Force late 1945. Dark Green upper surfaces and Light Blue lower sides. No upper wing national insignia. Spinner probably yellow.

